



24 Port Consolidation Point Box

Part Numbers: CUFMB24BL, CUFF-KIT

PN263A INSTALLATION INSTRUCTIONS

© Panduit Corp. 2002

Printed in U.S.A.

1.0 COMPONENT IDENTIFICATION

CUFMB24BL

PARTS:

- (1) Metal Box
- (1) Cover
- (4) Faceplate Inserts (removable)
- (4) Labels and Label Covers
- (4) *TAK-TYS*[™]

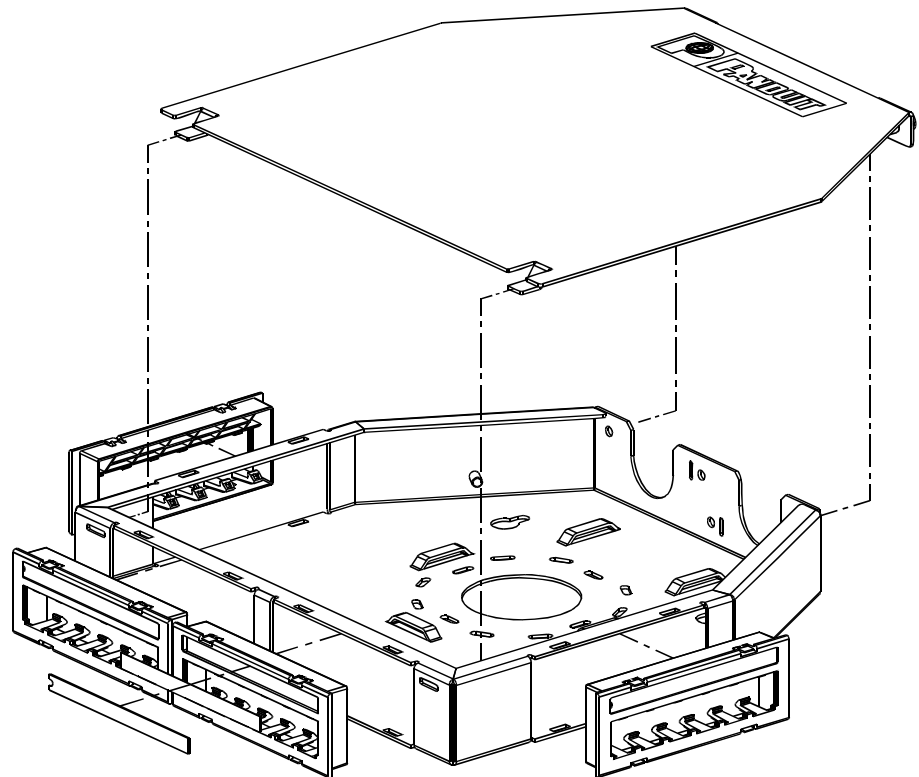
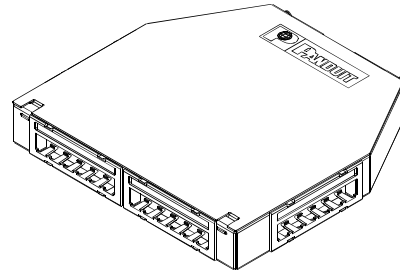

FIBER CONVERSION KIT (Sold Separately)

CUFF-KIT

PARTS:

- | | |
|------------------------------------|--------------------------|
| (2) Spools with Adhesive Backing | (1) Fiber Caution Label |
| (2) Strain Relief Clips | (1) Spiral Wrap 24" long |
| (1) Grounding Lug | (4) Panduit Cable Ties |
| (1) Fiber Laser Beam Warning Label | (2) Rubber Grommets |
| (4) Wire Saddles | |

- Notes: 1. Kit works with both CUFMB24BL and CUFMB48BL.
2. Depending on the product being assembled for use with fiber, some kit components may be left over.

FOR TECHNICAL SUPPORT CALL: 866-405-6654

2.0 Box Assembly

- 2.1 Set box on flat work surface. Snap the (4) Faceplate Inserts in place. Label slots should be located above modules.
- 2.2 Terminate copper modules. (See PN120*). Then snap modules into Faceplate Inserts.
- 2.3 Use *TAK-TYS*™ to secure the cables to the raised tabs in the floor of the box.

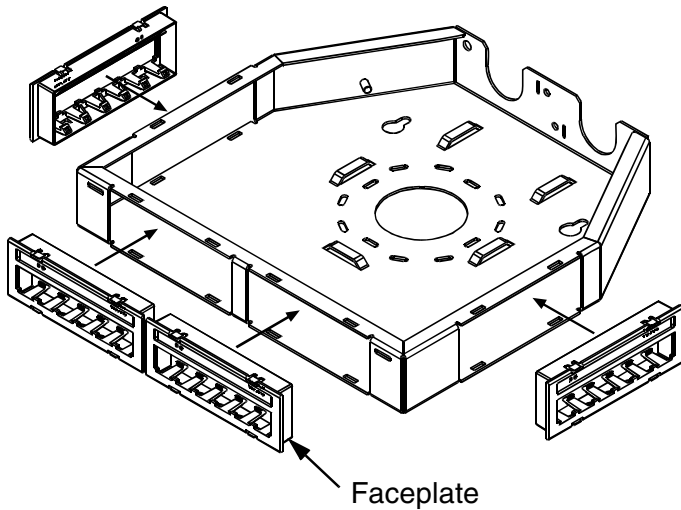

2.1

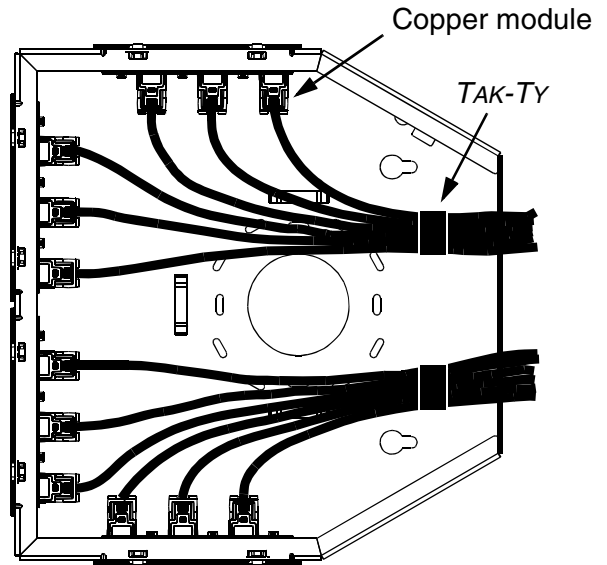

2.3

3.0 Cover Assembly

- 3.1 To install the cover, slide the cover tabs into slots, then twist both thumb screws to secure the cover. To remove the cover, unscrew both thumb screws, then slide and lift cover out.

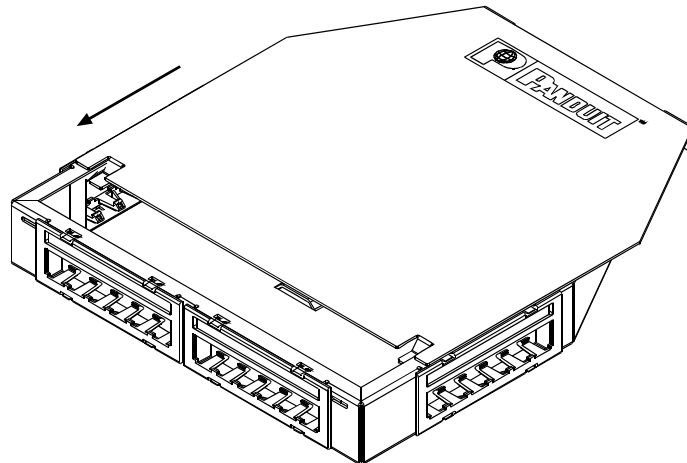

3.1

WORLDWIDE SUBSIDIARIES AND SALES OFFICES



10500 West 167th Street
Orland Park, Illinois 60467

Technical Support: 866-405-6654
Fax: 708-444-6993

E-mail: ncginfo@panduit.com
Web site: www.panduit.com/ncg