



SAPPB2D-08X0049

Safe Robotics Area Protection

SAFETY SYSTEMS FOR ROBOTS

SICK
Sensor Intelligence.

Ordering information

sBot Stop



Robot restart	Primary protective device (access control)	Secondary protective device (presence detection)	Type	Part no.
Automatic	Safety light curtain deTec4 Core Protective field height: 1,500 mm Resolution: 30 mm	Safety laser scanners microScan3 Core I/O Protective field range: 5.5 m	SAPPB2D-08X0049	1097909

This system variant enables an automatic restart of the robot.

Other models and accessories → www.sick.com/Safe_Robotics_Area_Protection

Detailed technical data

Features

Variant	sBot Stop
Product type	Hardware and logics
Robot controller	Generic
Stopping process of the robot	Stop only
Robot restart	Automatic
Interfaces	
Communication interface	Discrete I/Os
Safe state in the event of a fault	The safety-related semiconductor outputs are in the OFF state.
Safety laser scanners	microScan3 Core I/O
Protective field range	5.5 m
Safety task	Hazardous area protection
Ambient operating temperature	-10 °C ... +50 °C
Storage temperature	-20 °C ... +50 °C
Air humidity	90% at 50 °C (EN 61131-2)
Safety sensors	
Primary protective device (access control)	Safety light curtain
Secondary protective device (presence detection)	Safety laser scanners
Safety light curtain	deTec4 Core
Protective field height	1,500 mm
Resolution	30 mm
Scanning range	15 m
Safety controller included	Flexi Classic
Safety controller type	Non programmable
Voltage supply	
Supply voltage V_S	24 V DC (16.8 V DC ... 28.8 V DC)

Performance level	PL d (ISO 13849-1)
Items supplied	microScan3 Core I/O safety laser scanner deTec4 Core safety light curtain 1,500 mm sender and receiver Flexi Classic main module UE410-MU4T0 Flexi Classic UE410-8DI4 module safety controller FlexFix brackets Documentation (operating instructions, SISTEMA file, wiring diagram)

Functions

Emergency stop	
Shut down in the event of an emergency situation	✓
Prevent unexpected restarting after an emergency stop	✓
Initiate a safety stop	
Automated reset	✓
Operating mode	
Operating mode selection (implemented in robot control)	✓

Classifications

ECLASS 5.0	27279090
ECLASS 5.1.4	27279090
ECLASS 6.0	27279090
ECLASS 6.2	27279090
ECLASS 7.0	27279090
ECLASS 8.0	27279090
ECLASS 8.1	27279090
ECLASS 9.0	27279090
ECLASS 10.0	27279090
ECLASS 11.0	27279090
ECLASS 12.0	27279090
ETIM 5.0	EC001449
ETIM 6.0	EC001449
ETIM 7.0	EC001449
ETIM 8.0	EC001449
UNSPSC 16.0901	32151705

Dimensional drawing (Dimensions in mm (inch))

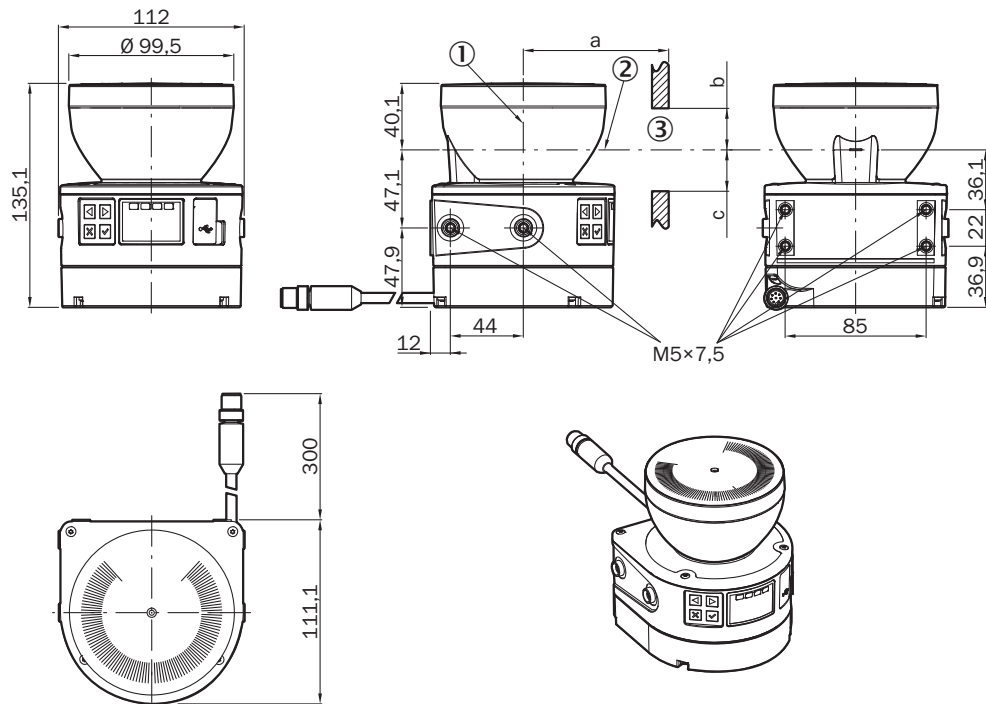

- ① Mirror axis of rotation
- ② Scan plane
- ③ Required viewing slit (a: length of the viewing slit, b: minimum height above the scan plane, c: minimum height below the scan plane. See the operating instructions for details.)

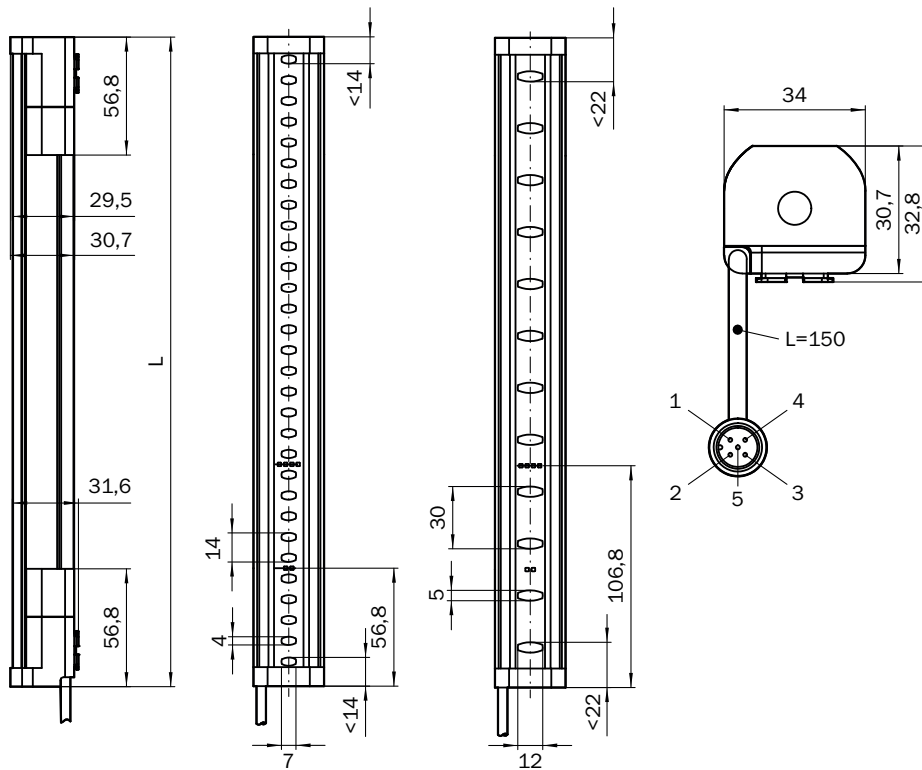

Flexi Classic main module

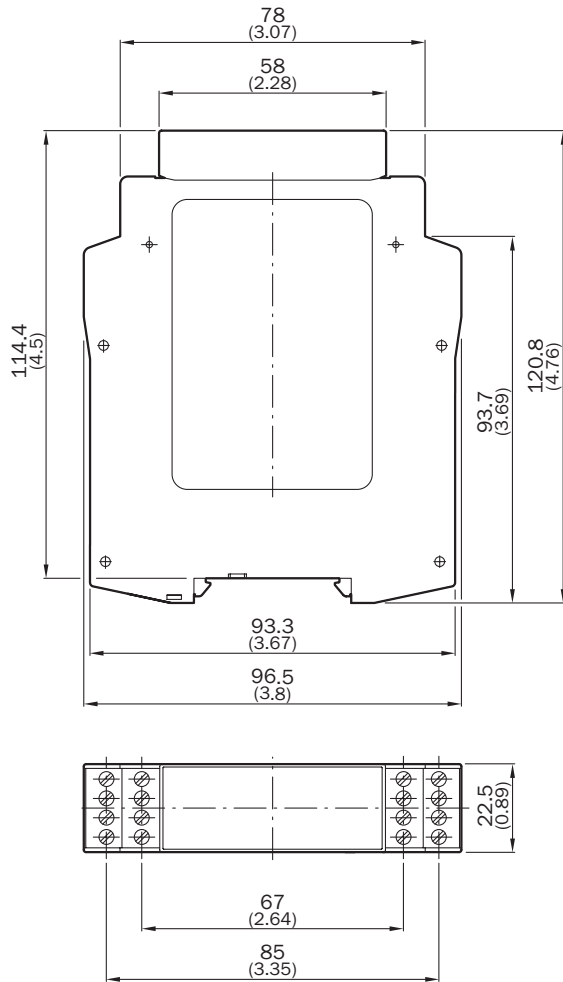

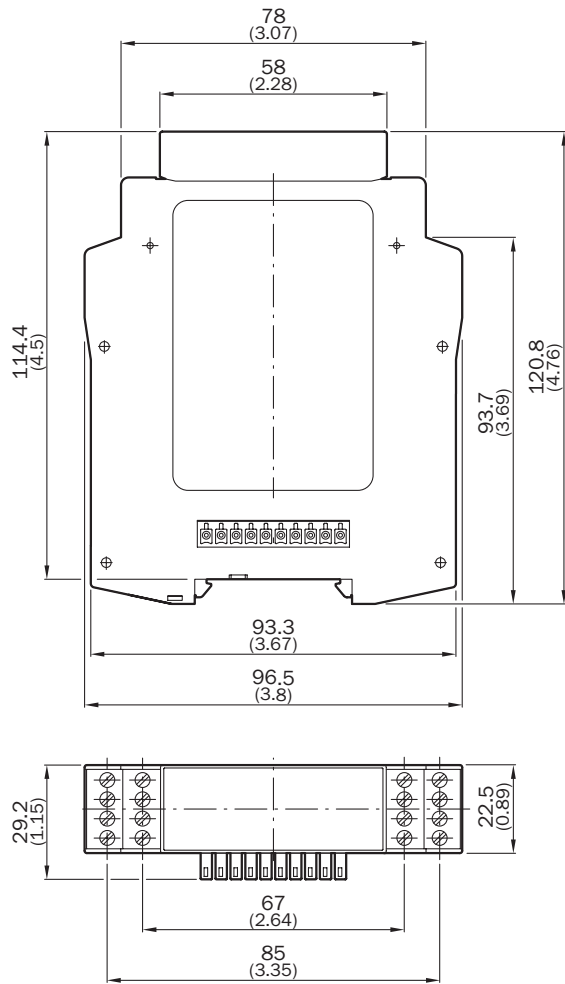

Protective field height	L
300 (11.81)	313 (12.32)
450 (17.72)	463 (18.23)
600 (23.62)	613 (24.13)
750 (29.53)	763 (30.04)
900 (35.43)	913 (35.94)
1,050 (41.34)	1,063 (41.85)
1,200 (47.24)	1,213 (47.76)
1,350 (53.15)	1,362 (53.62)
1,500 (59.06)	1,512 (59.53)
1,650 (64.96)	1,662 (65.43)
1,800 (70.87)	1,812 (71.34)
1,950 (76.77)	1,962 (77.24)
2,100 (82.68)	2,112 (83.15)

SICK AT A GLANCE

SICK is one of the leading manufacturers of intelligent sensors and sensor solutions for industrial applications. A unique range of products and services creates the perfect basis for controlling processes securely and efficiently, protecting individuals from accidents and preventing damage to the environment.

We have extensive experience in a wide range of industries and understand their processes and requirements. With intelligent sensors, we can deliver exactly what our customers need. In application centers in Europe, Asia and North America, system solutions are tested and optimized in accordance with customer specifications. All this makes us a reliable supplier and development partner.

Comprehensive services complete our offering: SICK LifeTime Services provide support throughout the machine life cycle and ensure safety and productivity.

For us, that is “Sensor Intelligence.”

WORLDWIDE PRESENCE:

Contacts and other locations –www.sick.com