



Installation manual
Installationsanleitung
Installatiehandleiding
Manuale d'installazione
Manual de instalación
Manuel d'installation

**External 3 kW booster heater for EKHWP300/500B hot
water storage tank**

Copyright © Daikin

Content / Inhalt / Inhoud / Contenido / Contenu

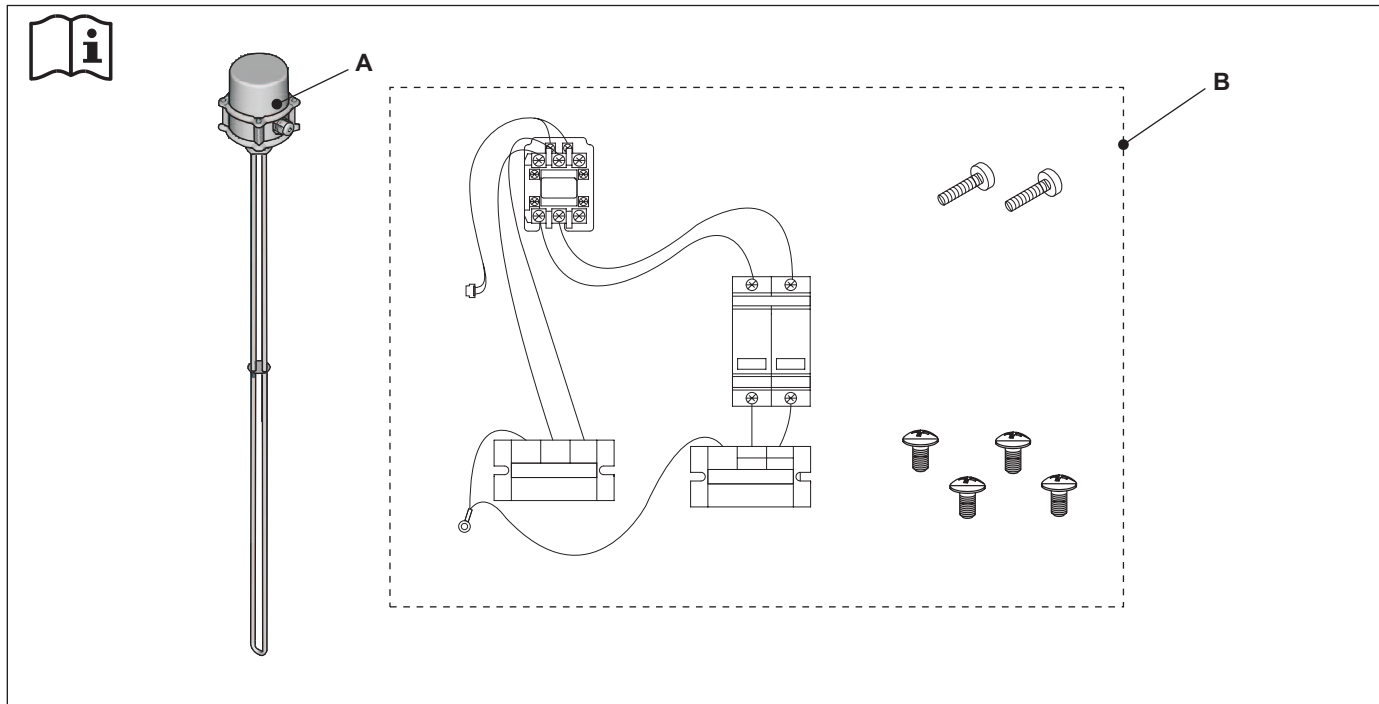

GB	DE, AT, CH	BE, NL	IT	ES	FR
- Documentation	Dokumentation	Documentatie	Documentazione	Documentación	Documentation
A Booster-Heater BO3S	Booster-Heater BO3S	Booster-Heater BO3S	Booster-Heater BO3S	Booster-Heater BO3S	Booster-Heater BO3S
B Contactor - fuse assembly	Schalterschütz - Sicherheitsbaugruppe	Schakelcontact - zekeringmontage	Gruppo del contattore - fusibile	Conjunto contactor - fusible	Contacteur - ensemble de fusible

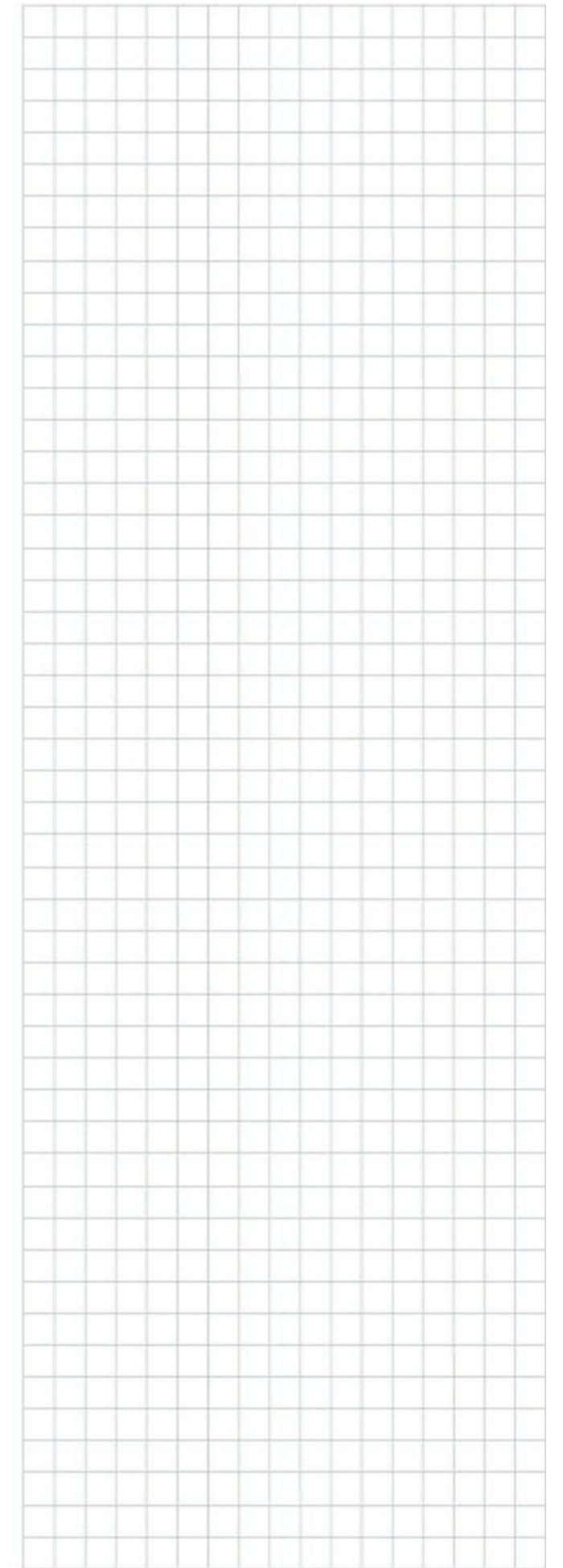

E(D)(B)LQ*

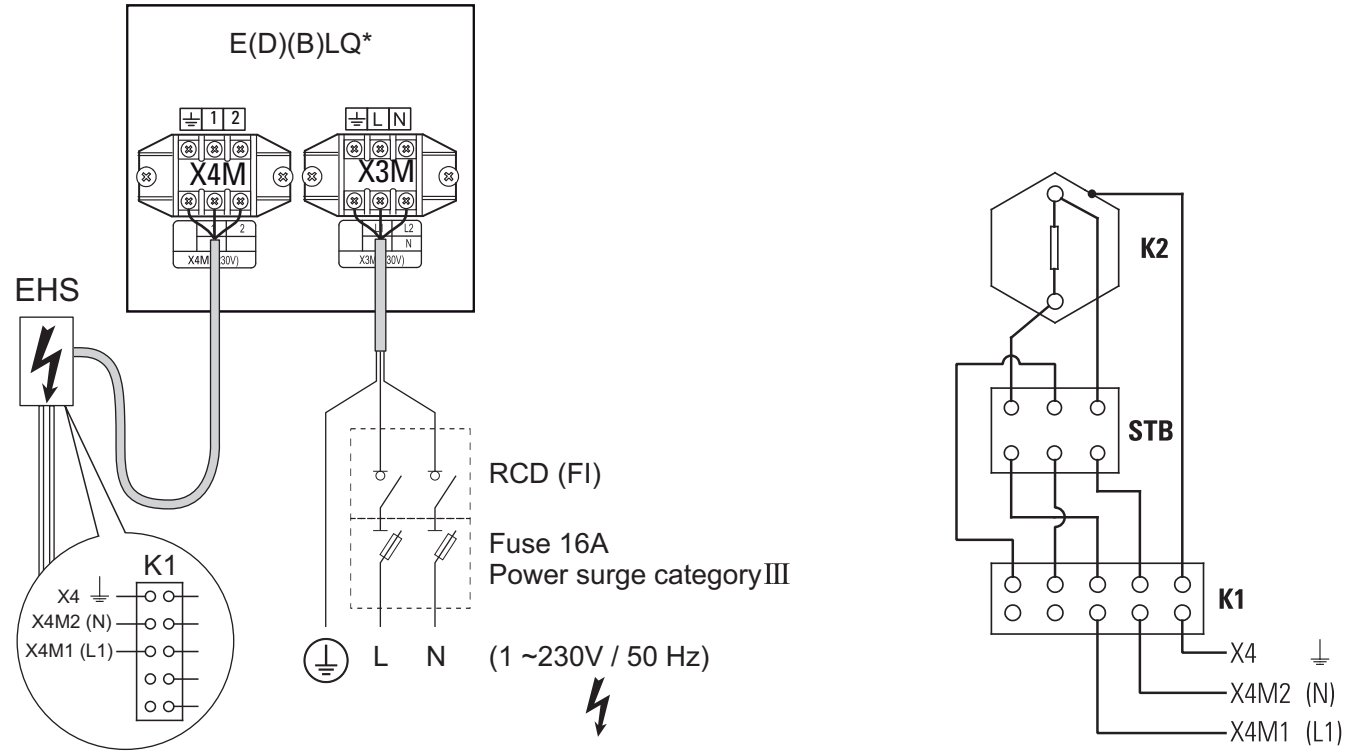

Assembling / Montage / Montage / Montaggio / Ensamblaje / Montage

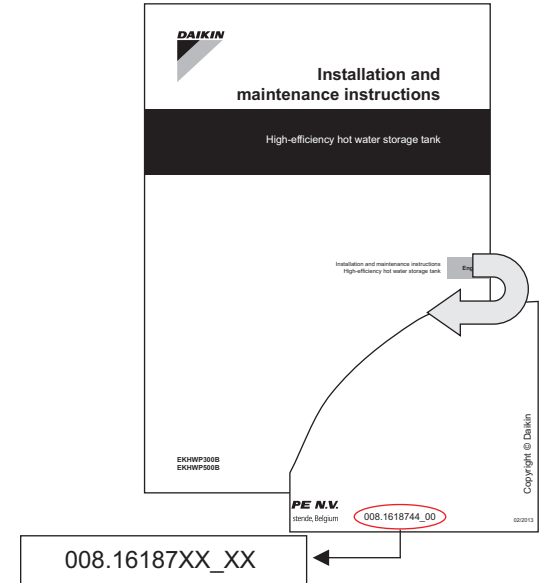
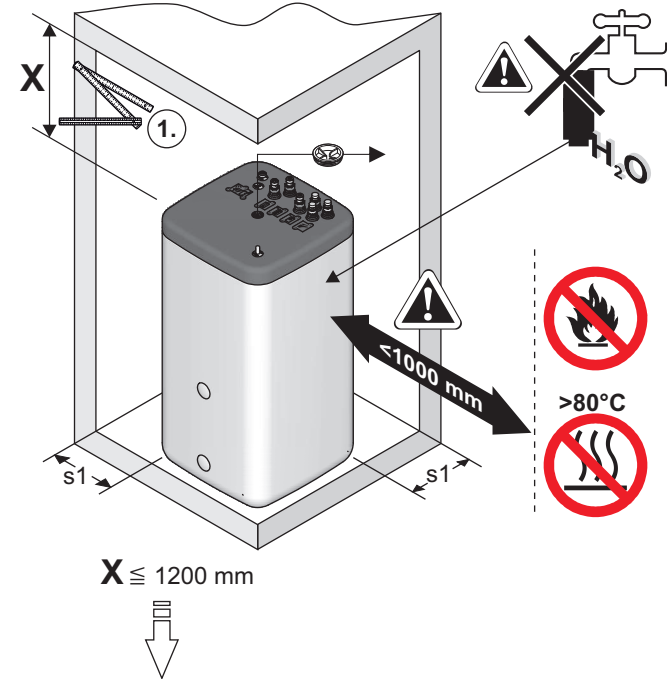

RKHB*

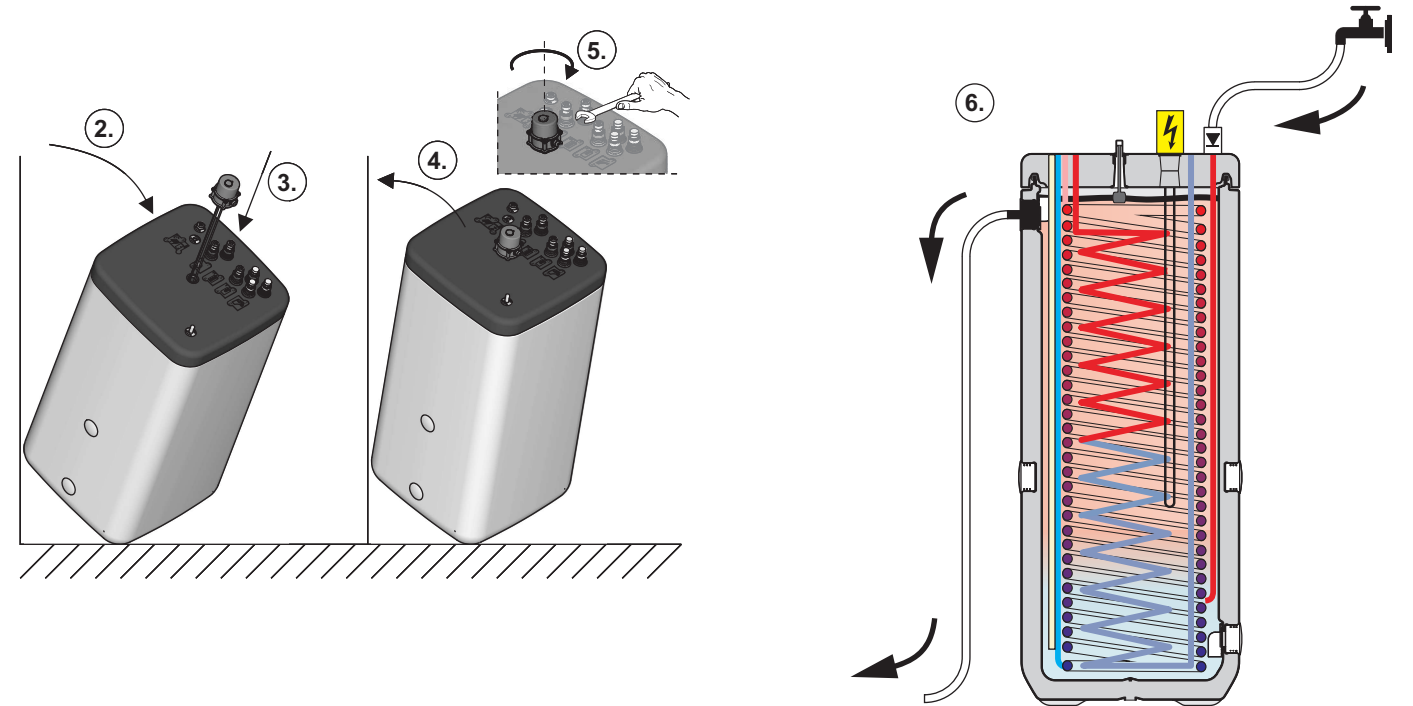
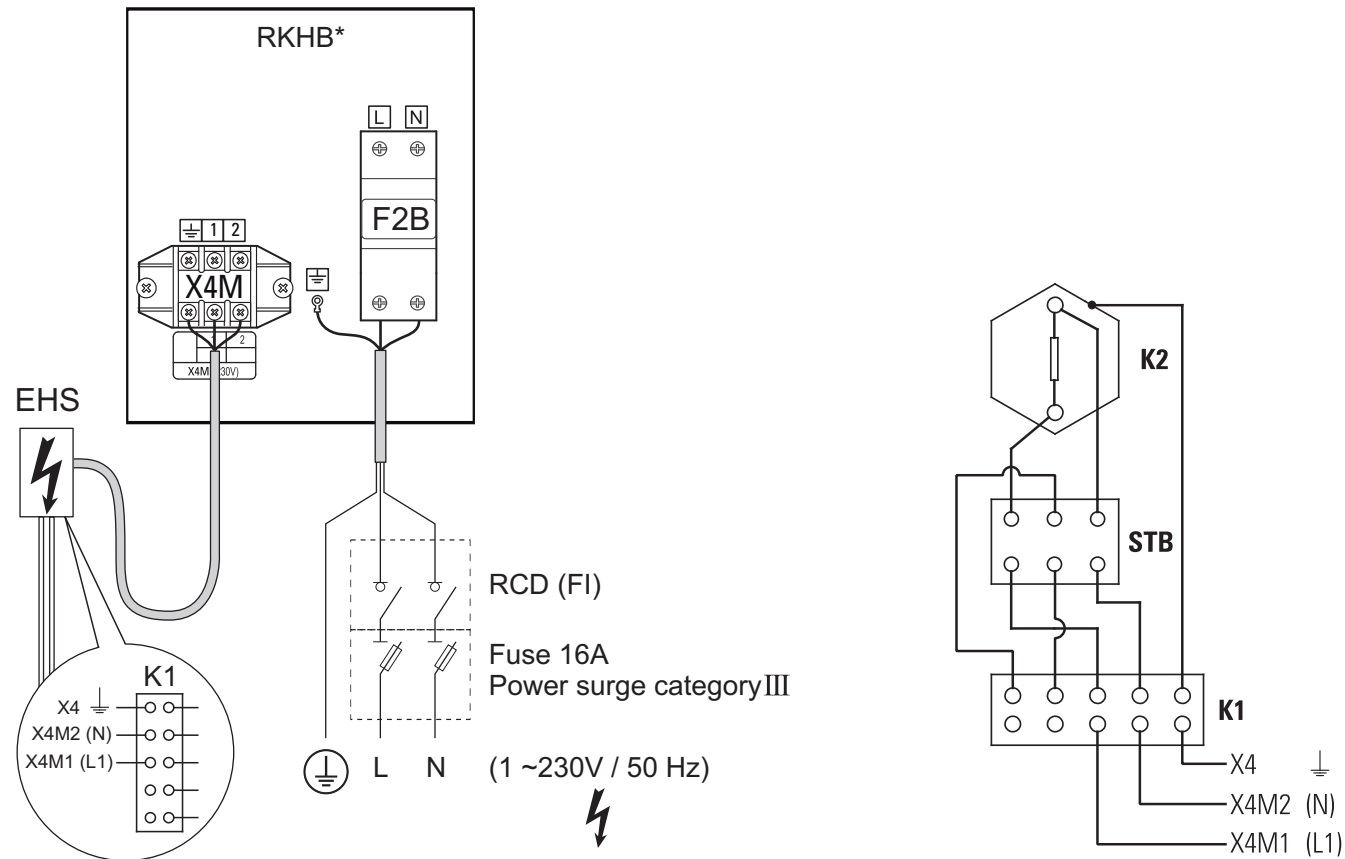

Electrical connection / Elektrischer Anschluss / Elektrische aansluiting / Collegamento elettrico / Conexión eléctrica / Connexion électrique

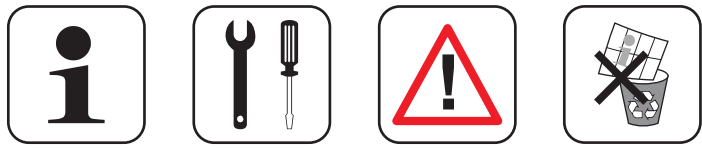

DE **Warnung:** Lebensgefahr durch Hochspannung!
GB **Warning:** Danger to life - high voltage!
IT **Avvertenza:** Pericolo di morte per alta tensione!
FR **Avertissement:** Danger de mort - Haute tension!
BE **Waarschuwing:** Levensgevaar door hoogspanning!
ES **Advertencia:** Peligro de muerte por alta tensión!

DE Vor Öffnen alle Stromkreise spannungsfrei schalten.
GB Before opening switch off all voltage circuits
IT Prima di aprire i circuiti elettrici togliere la tensione.
FR Mettre hors tension tous les circuits électriques avant ouverture.
BE Voor het openen, alle stroomkringen spanningsvrij maken.
ES Desconectar todos los circuitos de la alimentación eléctrica

007.15.161.99_01

