

**Components NOT Included**  
**Part of S\*\*SHD - Single Hinge**  
**Door SOLD SEPERATELY**

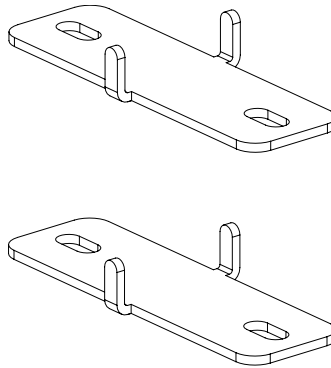

**Components NOT Included**  
**Part of Hardware Kit of**  
**FlexFusion Cabinet - SOLD**  
**SEPERATELY**

#### Tool List



T25 and T30  
Torx drivers

Utility Knife  
Or  
Flat Head  
Screwdriver

3mm Hex L-Key

#### Components Included

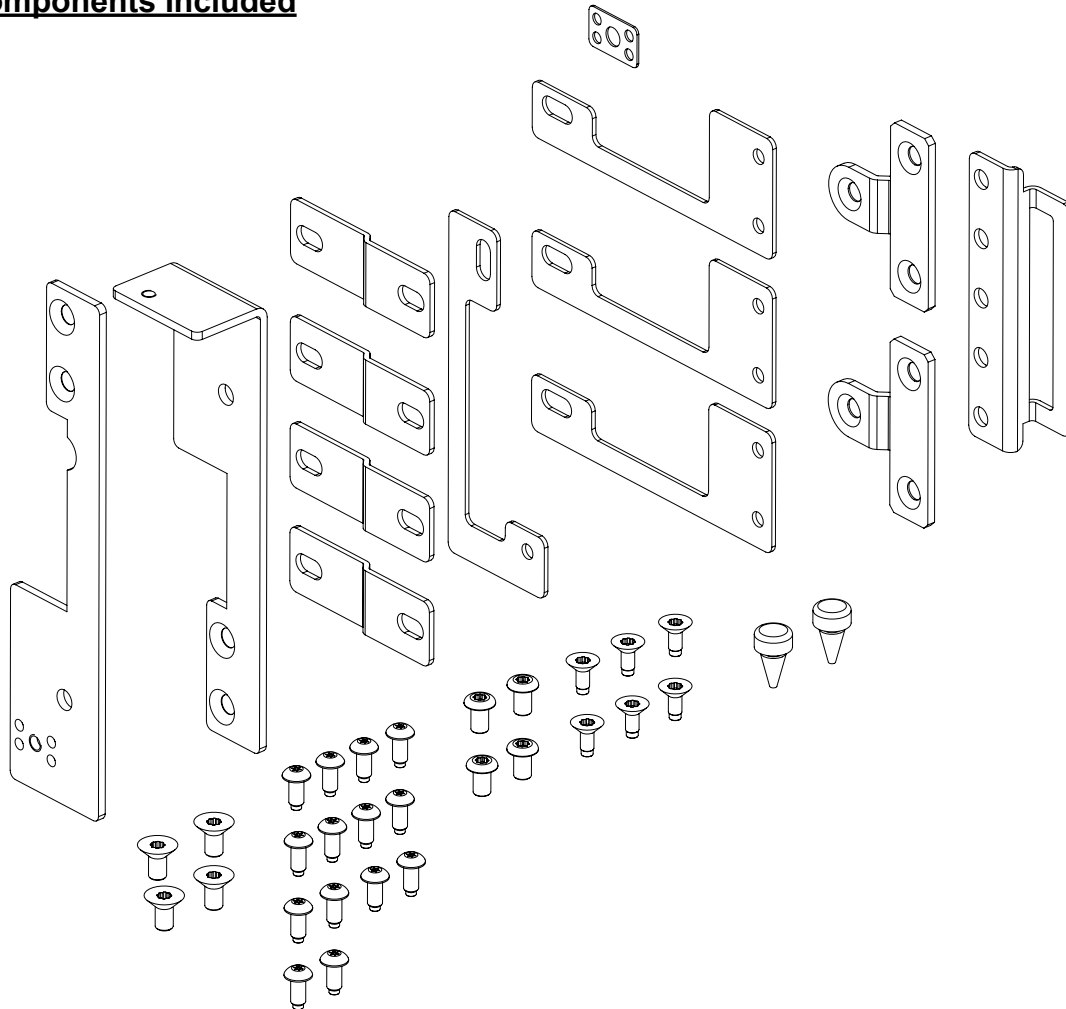

## **REMOVE TOP AND BOTTOM PLASTIC CAPS**

- Use Utility knife or screw driver to remove Plastic cap on top and bottom of cabinet. Discard caps.

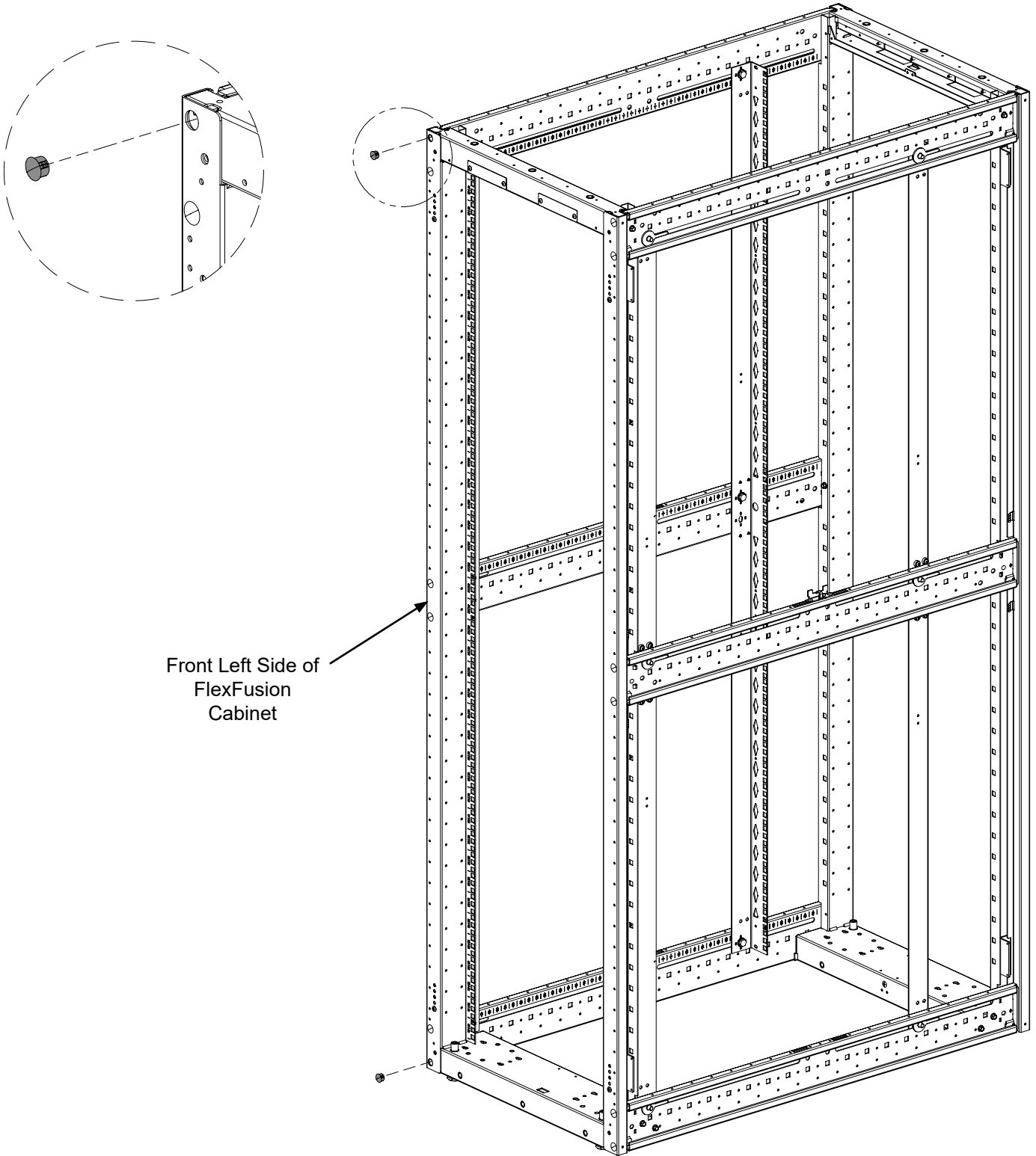

Front Left Side of  
FlexFusion  
Cabinet

## Install Top and Bottom Hinge Brackets

- Secure Top Hinge Bracket to upper left corner of cabinet using (1) M5 X 12mm Button Head screw, (2) M6 X 12 Flat Head Torx screw.
- Secure Lower Hinge Bracket to lower left corner of cabinet using (1) M5 X 12mm Button Head screw, (2) M6 X 12 Flat Head Torx screw.

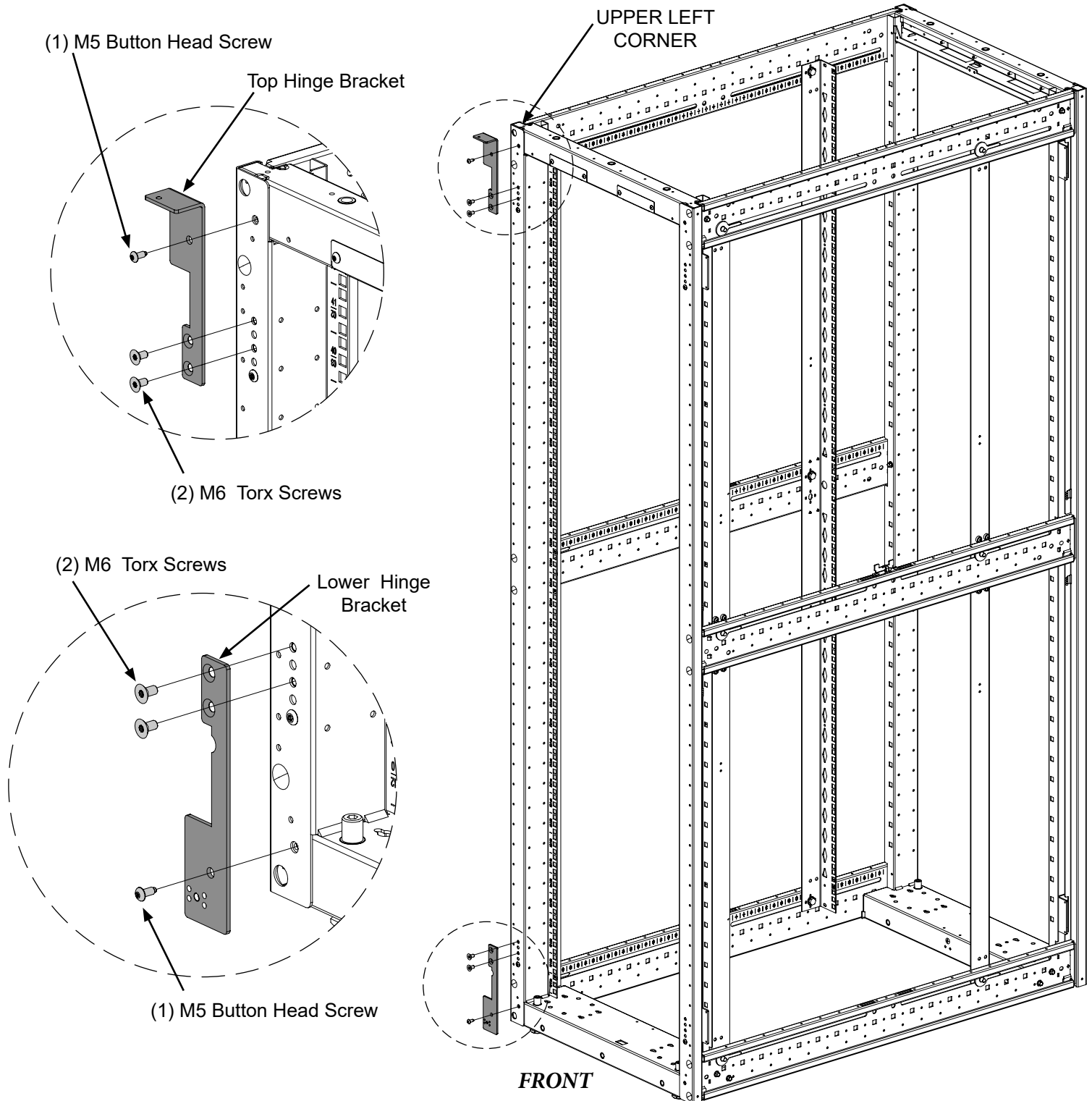

## Ganging FLEXFUSION™ Cabinet to NET-ACCESS Server (S-Type) Cabinet

- Ensure both cabinets are level and the same height across the top
- Secure (2) Ganging Brackets to cabinets at (2) front locations using (2) M6 X 10mm low profile torx screws and (2) M5 X 12mm Button Head Screws
- Secure (2) rear ganging plates to cabinets at (2) rear locations using (6) M5 X 12mm Trilob Flathead screw w/ nylon patch
- Use Ganging Brackets to cinch cabinets together

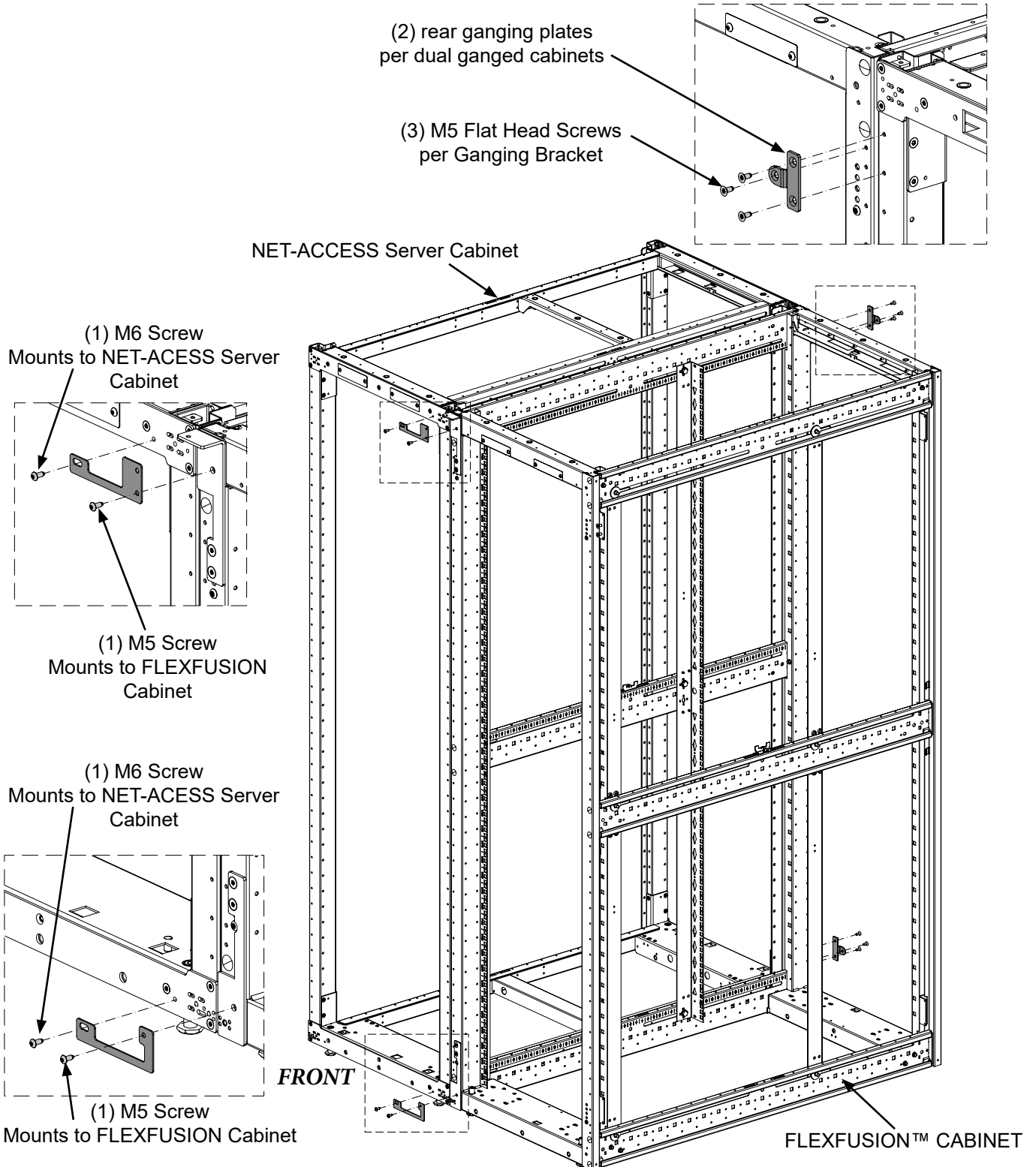

NOTE: DOORS, TOP CAPS, SIDE PANELS NOT SHOWN FOR CLARITY

For Technical Support: [www.panduit.com](http://www.panduit.com)

## Ganging FLEXFUSION™ Cabinet to NET-ACCESS Network (N-Type) Cabinet

- Ensure both cabinets are level and the same height across the top
- Secure (4) Ganging Brackets to cabinets at (2) front locations and (2) back locations using (4) M6 x 10mm low profile torx screws and (4) M5 x 12mm Button Head Screws.  
NOTE: (3) Ganging brackets used on Front Top; Rear Top; and Rear Bottom are identical with one mounting slot and two holes. (1) Front Bottom ganging bracket is unique; it has one mounting slot and single mounting hole.
- Use Ganging Brackets to cinch cabinets together

(1) M6 Screw Mounts to NET-ACCESS Network Cabinet  
(Repeat for Back Location)

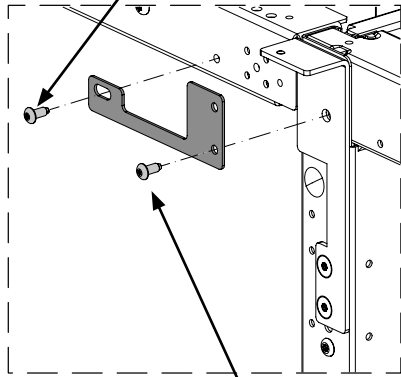

(1) M5 Screw Mounts to FLEXFUSION Cabinet  
(Repeat for Back Location)

(1) M6 Screw Mounts to NET-ACCESS Server Cabinet  
(Repeat for Back Location)

(1) M5 Screw Mounts to FLEXFUSION Cabinet  
(Repeat for Back Location)

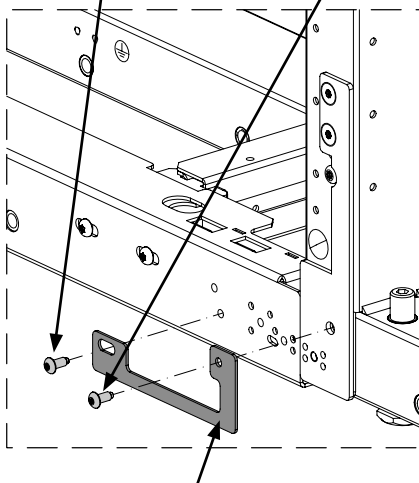

Unique Front Bottom Ganging Bracket with one mounting slot and one hole

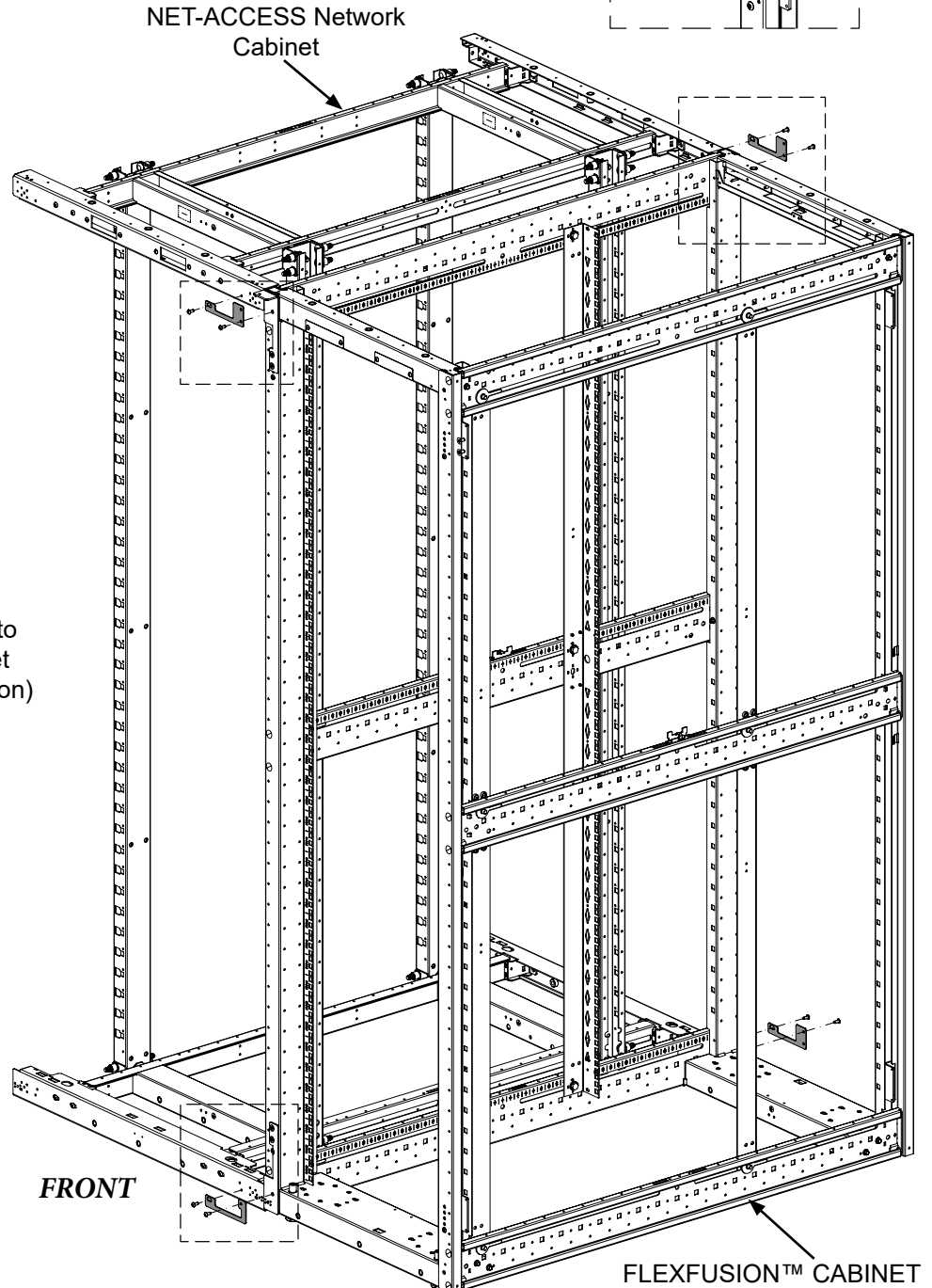
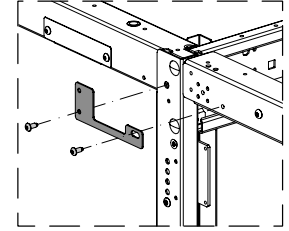

NOTE: DOORS, TOP CAPS, SIDE PANELS NOT SHOWN FOR CLARITY

For Technical Support: [www.panduit.com](http://www.panduit.com)

## Ganging FLEXFUSION™ Cabinet to FLEXFUSION™ CABINET

- Ensure both cabinets are level and the same height across the top
- Secure (2) Offset Ganging Brackets to cabinets at (2) front locations using (4) M5 x 12mm Button Head Screws.
- Secure (2) Universal FLEXFUSION Ganging Brackets with Tabs to cabinets at (2) rear locations using (4) M5 x 12mm Button Head Screws.
- Use Ganging Brackets to cinch cabinets together

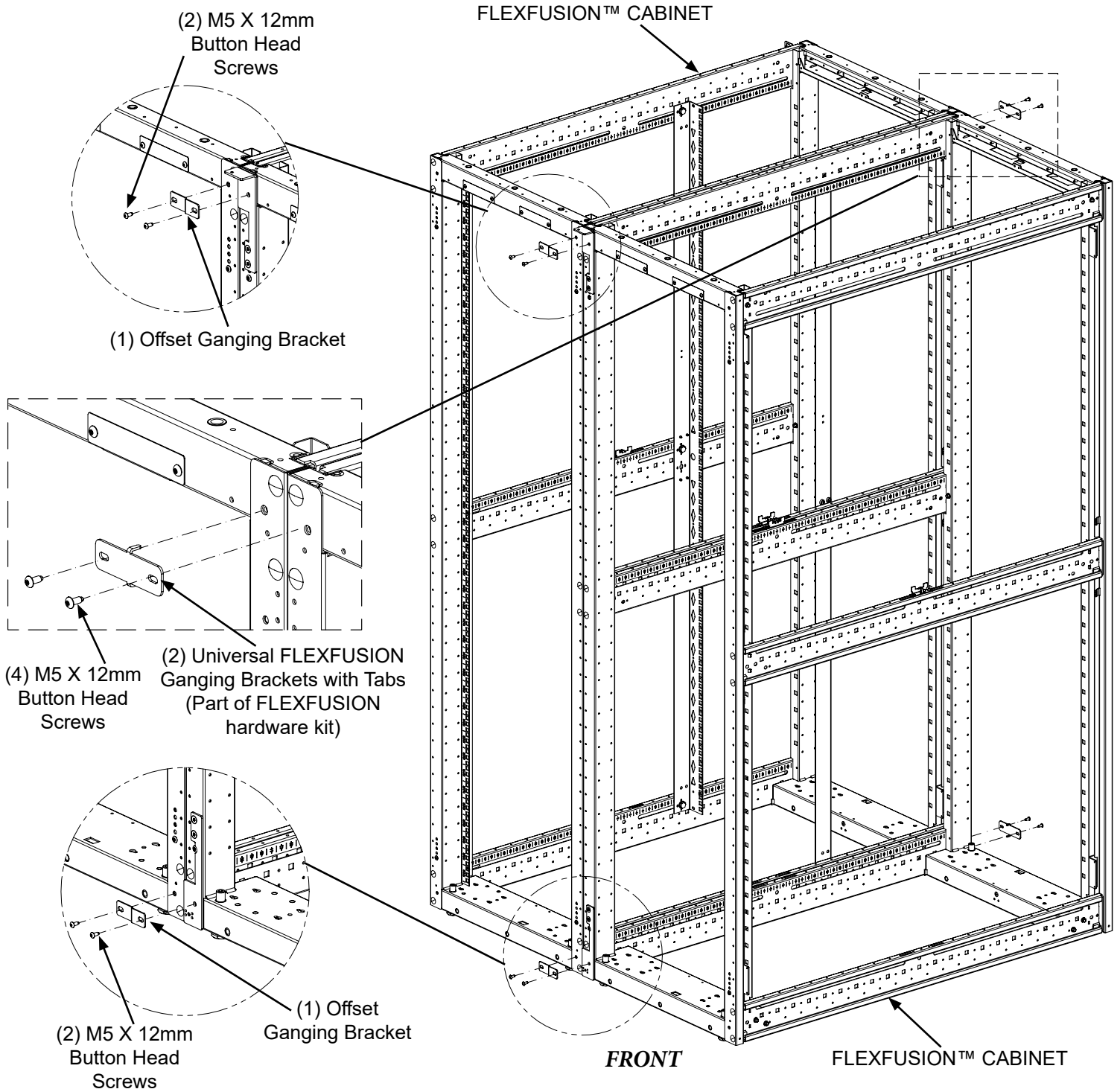

NOTE: DOORS, TOP CAPS, SIDE PANELS NOT SHOWN FOR CLARITY

For Technical Support: [www.panduit.com](http://www.panduit.com)

**INSTALL DOOR HINGES FROM EXISTING S-TYPE DOOR. INSTALL CAM CATCH BRACKET AND BOTTOM DOOR SHIM FROM THE KIT**

- Install Release collar, Compression Spring & Shoulder Bolt use 3mm HEX-L-KEY
- Secure Cam Catch Bracket from Kit to Frame using (2) M5 X 12mm Button Head Screws
- Secure Hinge Bracket to Frame using Bottom door shim from kit, existing bottom hinge pin and torx screw using T30 Torx drive
- Install existing Delrin washer over Bottom Hinge Pin

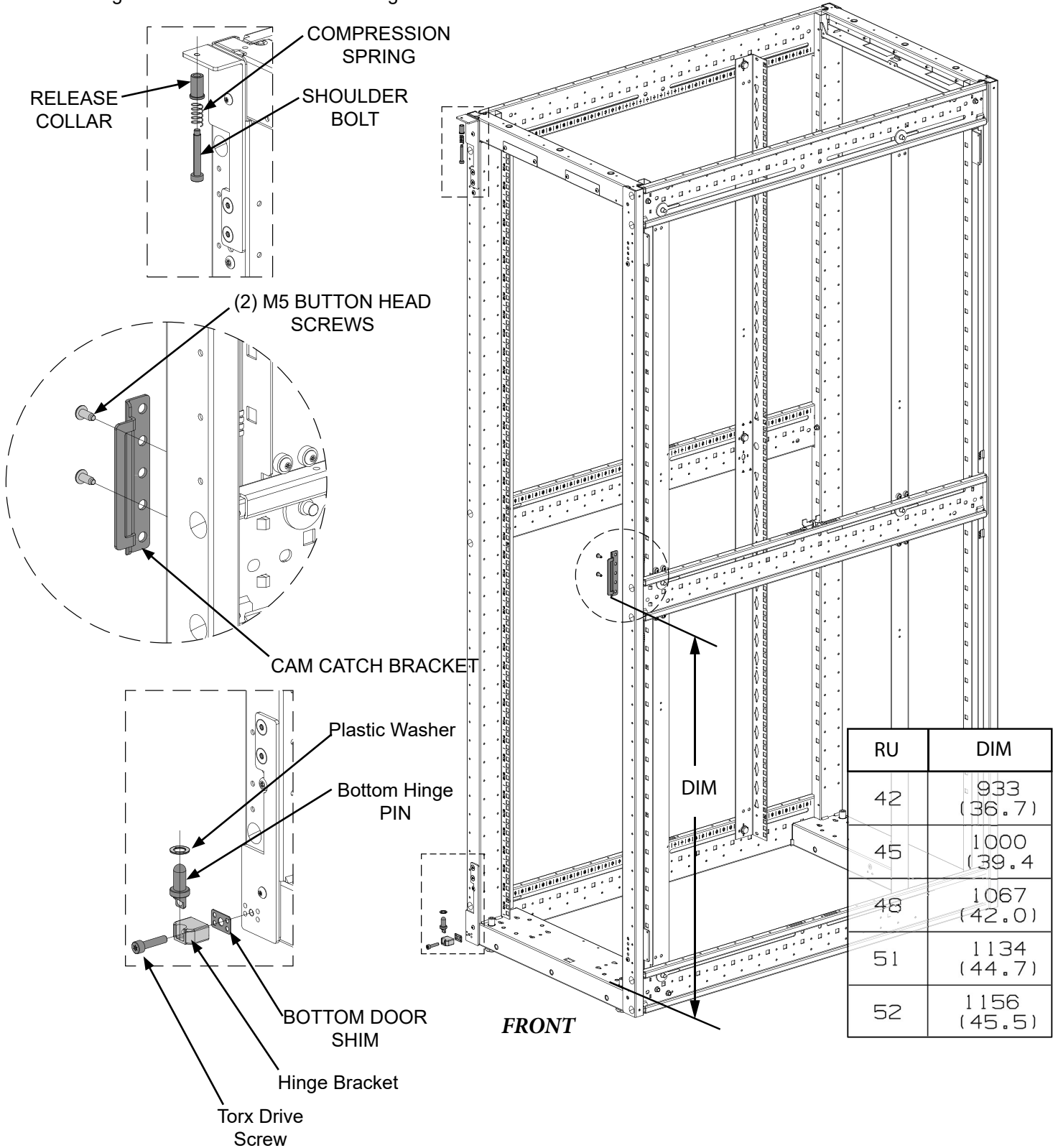

**For Technical Support: [www.panduit.com](http://www.panduit.com)**

## S-Type Door (Installation and Removal) and Bumper Replacement

- VIEW 2 Lift bottom of door onto Bottom Hinge Pin
- VIEW 1 Pull down Compression Sleeve at top door hinge
- VIEW 1 Push Single Hinge Door towards cabinet so that Top Hinge Screw fits through cutout of door
- VIEW 1 Release Compression Sleeve
- REVERSE STEPS to remove Single Hinge Door
- Replace top and bottom bumper with new bumpers from the kit

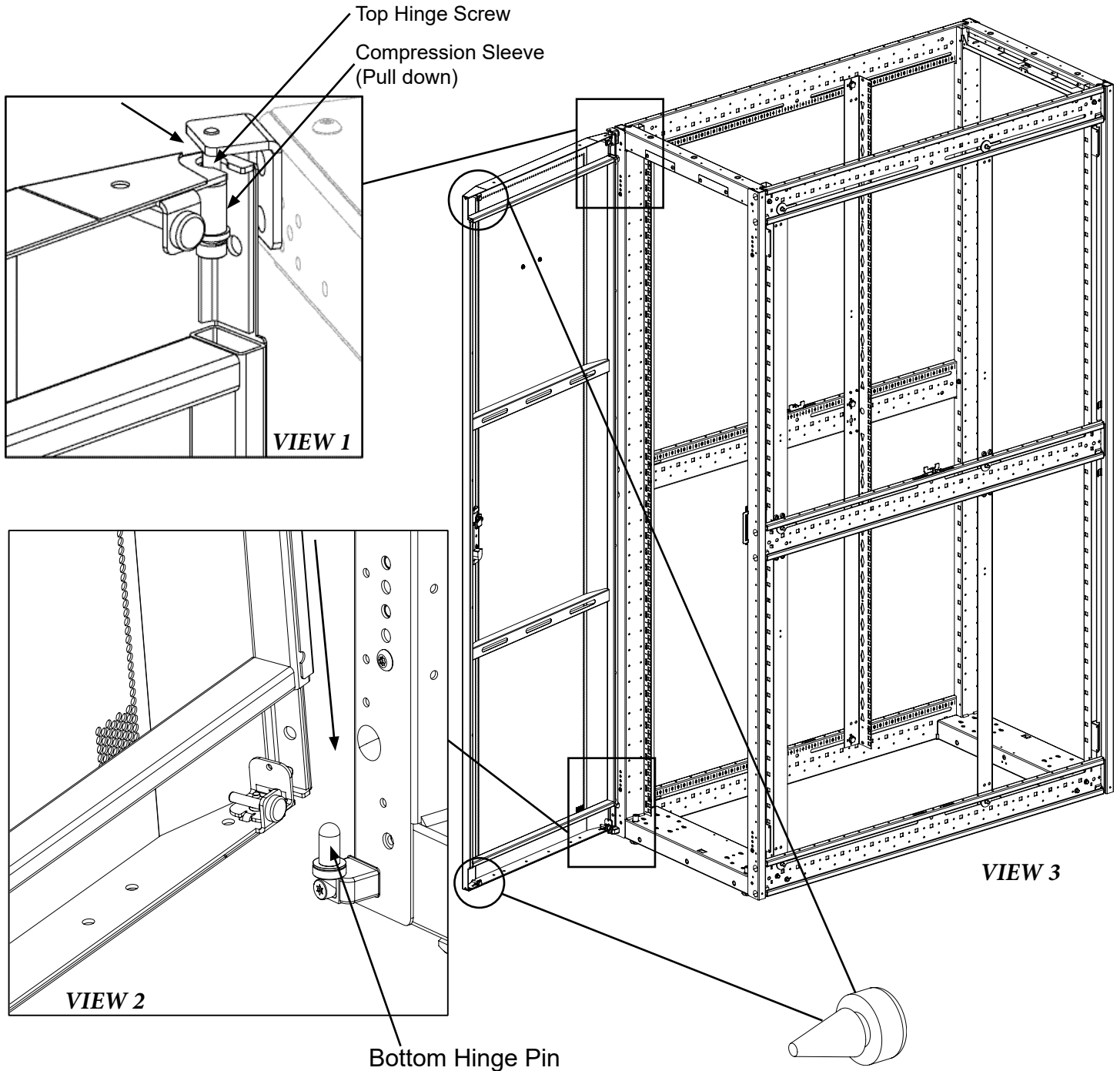

For Instructions in Local Languages  
and Technical Support:

[www.panduit.com](http://www.panduit.com)

**PANDUIT**  
[www.panduit.com](http://www.panduit.com)

E-mail:  
[techsupport@panduit.com](mailto:techsupport@panduit.com)

Phone:  
866-405-6654