

THIS COPY IS PROVIDED ON A RESTRICTED BASIS AND IS NOT TO BE USED IN ANY WAY DETRIMENTAL TO THE INTERESTS OF PANDUIT CORP.

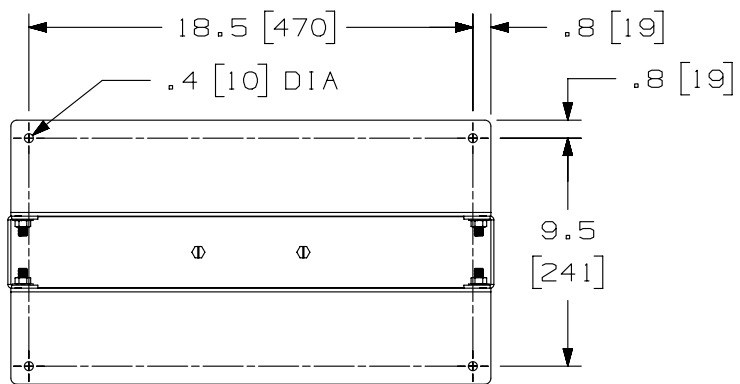

PANDUIT P/N	WEIGHT
R2P26	9.00 LB/1 PC (4,479 g/1 PC)

- NOTES:
- SEE CATALOG FOR COMPLETE LIST OF PARTS APPLICABLE FOR USE WITH THIS PART.
 - DIMENSIONS IN PARENTHESES ARE IN METRIC.
 - RACK TO BE ASSEMBLED BY CUSTOMER, HARDWARE INCLUDED, WITH PAINT PIERCING WASHERS.

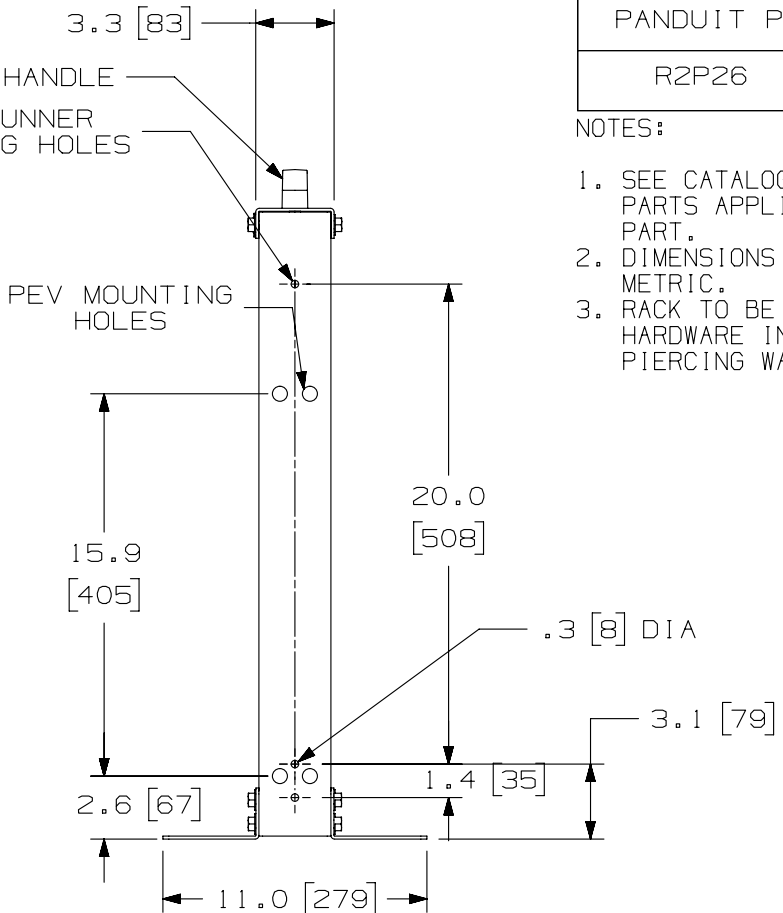
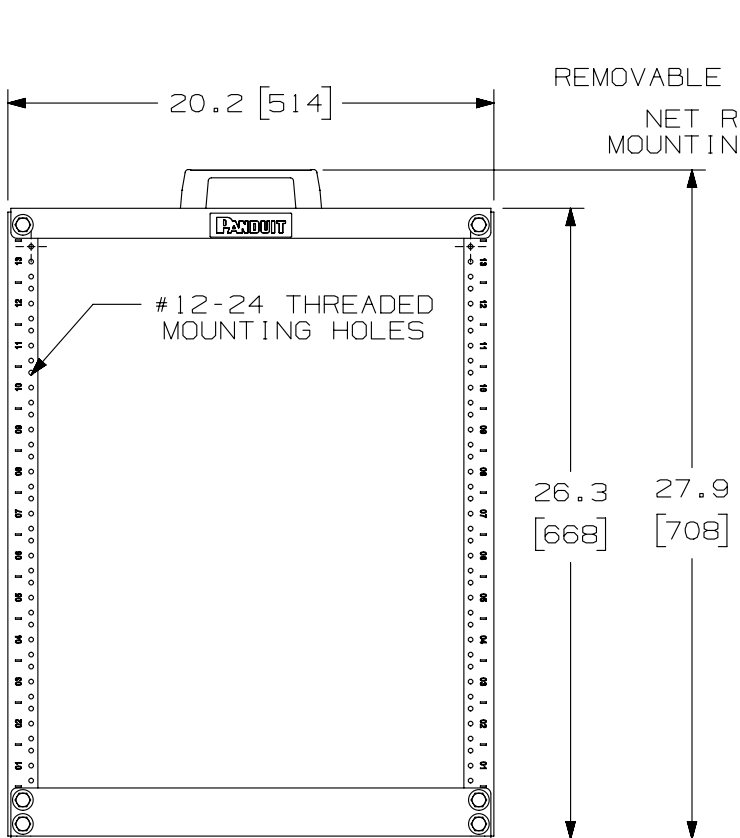
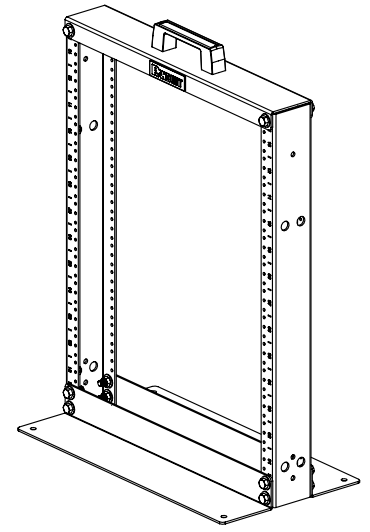

TITLE		CUSTOMER DISPLAY RACK (R2P26)	
CUSTOMER DRAWING			
ITEM REVISION NAME	09V064AA/03	PANDUIT TM	
DATASET FILE NAME	09V064AA_DC/03A		
MATERIAL:			
DRAWING NUMBER:		09V064AA-DC	
THIRD ANGLE PROJECTION			
DRAWN BY	DATE	CHK	SCALE
BAME	12-6-10	PM	NONE
SHT 1 OF 1		SIZE	
		A	

REV	DATE	BY	CHK	APR	DESCRIPTION	ECN
03A	11-14-13	BAME	PM	CMK	REVISED VIEWS AND TITLE BLOCK	09V064AA-DC
01A	12-6-10	BAME	NAGL	CMK	DRAWING RELEASED	09V064AA-DC

D10100DA/12