

# MG350C-24F

## SmartX Globe Valve Actuator



### Product Description

The MG350C-24F is a compact electro-mechanical actuator for controlling the VG210 and VG310 two-way and three-way linear globe valves.

The MG350C-24F is a dual, 2 position / 3 point floating actuator within the SmartX Actuator family. The MG350C actuators are primarily designed for applications where the demands on speed and thrust are relatively small, such as:

- Mixing and injection heating circuits
- Small air handling systems
- Large Fan coil units

### Features

- High Functionality
  - Stable force control with stall protection
  - Dual 3 Point floating and 2 position control.
  - Sink or source floating control
  - High Resolution PCBA and motor transmission for fine valve plug position and excellent flow control.
- LED status indication
  - Bi-color LED to indicate direction of movement when under power.
- Removable terminal block and cable gland for ease installation
- Compact Construction: Optimally designed to fit with the Venta VG210 and VG310.

### Specifications

Supply voltage	24 Vac/dc $\pm$ 20% 50/60 Hz
Power Consumption (50Hz) Running	3.5 W
Transformer sizing	5 VA
Running Time	8 s/mm (Full stroke time, VG210 / VG310 = 88 sec)
Max. Stroke	6.5 mm
Force Nominal	350 N
Control	Dependant upon wiring, page 3
3 wire Floating	24 Vac/dc or 0V
2 Position on/off	NO or NC
Minimum input pulse	100 msec
Environmental Ambient operational temperature range	-5...+55°C (for valve fluid temperatures up to 130°C)
Storage temperature range	-40...+70°C
Ambient humidity	max . 95% RH (NC)
Protection rating	IP 53 (vertically mounted)

Sound power level	max. 30 dBA
Weight (shipping)	0.673 kg
Key Materials Yoke	Aluminum
Material Housing (Covers)	PBT/PC
Standards	EMC 2004/108/EU, EN 61326-1:2006 & EN 60730-2-9 & UL 60730-1(2-14)
Emission/Immunity	
Heat	IEC-68-2-2
Humidity	IEC-68-2-3
Cold	IEC-68-2-1
Vibration	IEC-68-2-6
Mechanical Manual Override	3 mm Hex (T style hand tool recommend)
Position indication	Yoke position indicator with red and blue position markers for hot and cold pipe indication (green position indicator for closed valve)
Cable Gland wire size	2.4 to 6.6 mm
Conduit hole	M20

## Function

### Actuator

The actuator utilizes a stepper motor to accurately position the main spindle via a gearbox based on the control signal received from the controller.

### Control Signal

This MG350C-24F SmartX Actuator series can be controlled either by 3 wire floating (increase/decrease) switched either between the 24 Vac/dc supply or by the 0V return. 2 position control for the actuator to retract or extend (IN/OUT) proving a normally open or normally closed valve is possible by configuring the wiring, see wiring diagrams on page 3.

## Mounting

Mount the actuator horizontally, vertically, or in any position in between, but not upside down. If the media temperature is above 120°C, install the actuator at an angle over the pipe-work to reduce the radiant heat influence.

For water ingress protection, do not mount actuators below the horizontal plane of the valve. IP63 will be achieved with a mounting orientation from vertical to 60 deg. IP51 will be achieved to 85 deg.

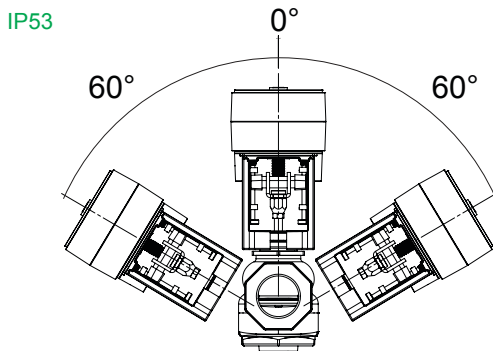

### Mounting the Actuator on the VG210/VG310 Valve

The VG210 / VG310 valves need the 18mm stem high connector fitted; this is provided with the actuator for new installations. The actuator is delivered so it is not needed to operate the manual override to assemble the product.

1. Position the valve stem by hand to align with the actuator clasp (1).
2. Pull the valve stem up and slide the actuator onto the valve neck, aligning the groove on the stem connector into the slot of the actuator clasp.
3. Push the actuator down and insert the U-bolt brace and secure with the flanged nuts.

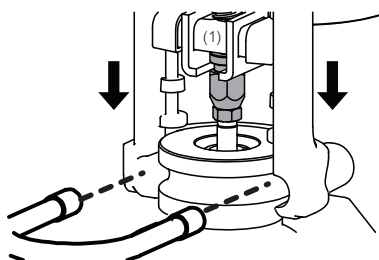

4. Tighten and secure the valve stem flanged nut.

## Dimensions (mm)

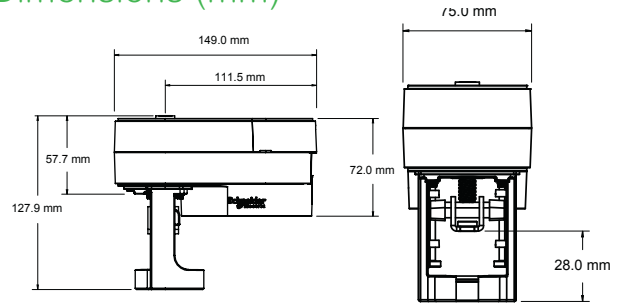

## Manual Operation

**⚠ WARNING**

**RISK OF BURNS OR FLYING PARTS**  
If the valve stem, spindle, or plug has been damaged, it may blow out under pressure while servicing the actuator.

- Isolate and depressurize the valve before servicing.
- Manually check valve stem, spindle, or plug integrity by moving it within the valve. If the part can be removed, replace the valve assembly.

**Failure to follow these instructions may result in death or serious injury.**

A 3mm hex key can be used to manually drive and position the MG350C SmartX Actuator. Do not depress the hex key during normal operation. The hex key is not supplied with the actuator.

The Hex key should be depressed firmly to disengage the main drive motor and continue to be depressed whilst rotating the key to adjust actuator position. It takes approximately 3 full rotations of the manual override to fully stroke the valve, each manual override turn moves the valve stem about 4 mm. There may be a load click as the main drive motor re-engages after a manual operation.

### Maintenance

The actuator is maintenance-free.

## Colored Valve Limit Indicators

It is recommended to set-up the colored valve end stop limits according to the valve and media during commissioning. Position the limits as follows:

Green end stop	Closed valve
Red end stop	Open heating circuit
Blue end stop	Chilled water circuit

### Terminal Block Connection

Y1	24 $\perp$	Y2
Extends the actuator linkage and lowers the valve stem	24 Vac/dc supply for sinking 24 Vac neutral or 24 Vdc common for sourcing	Retracts the actuator linkage and raises the valve stem

**NOTE:** The MG350F-24F actuator is powered by Y1 and/or Y2. If both Y1 and Y2 are powered at the same time, then the actuator retracts linkage and raises the stem.

### Cable Information

Cable type	Maximum length	Minimum cross sectional area
Power	100 m (328 ft)	1.5 mm <sup>2</sup> (AWG 16)
Control / Feedback	200 m (656 ft)	0.5 mm <sup>2</sup> (AWG 20)

### Direction of Operation

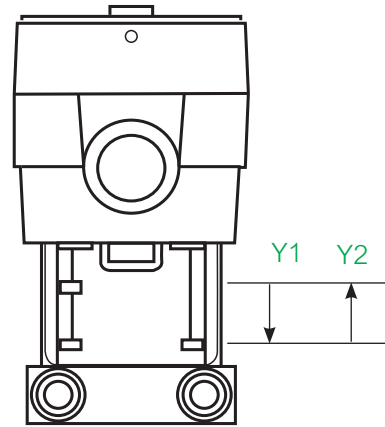

### Wiring

#### Three Wire Floating Wiring

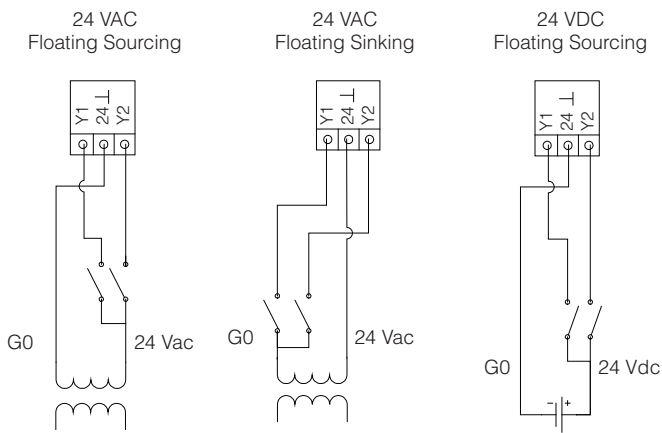

#### Two Position (On/Off)

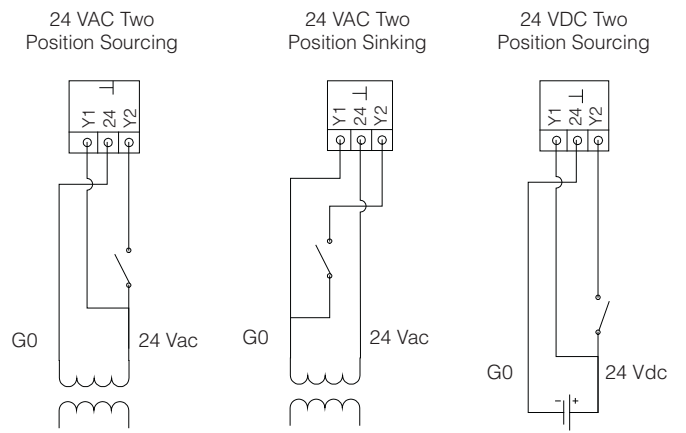

### Normal LED Operation

LED Color	Blinking pattern	Function
Orange	light 0.3 sec, every second	Indicates actuator is extending, lowering the valve stem to open the valve
Green	light 0.3 sec, every second.	Indicates actuator is retracting, lifting the valve stem to close the valve

