

THIS COPY IS PROVIDED ON A RESTRICTED BASIS AND IS NOT TO BE USED IN ANY WAY DETRIMENTAL TO THE INTERESTS OF PANDUIT CORP.

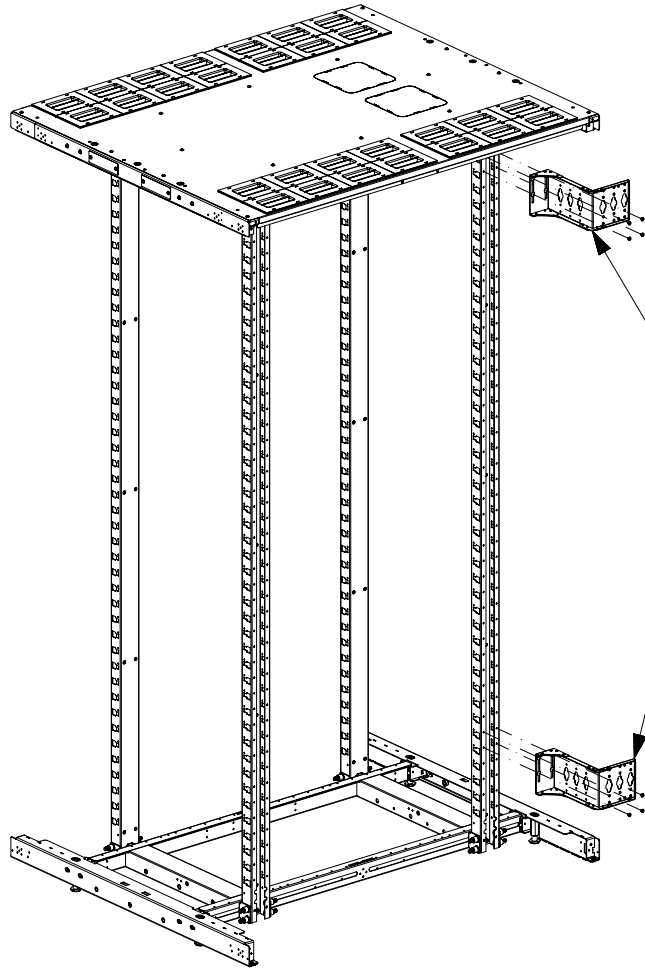

PDU MOUNTING BRACKET CAN BE ADJUSTED VERTICALLY ALONG CABINET PER RACK SPACE

APPLICATION VIEW  
CABINET NOT INCLUDED

PANDUIT P/N	WEIGHT
NVPDUB7018	1.4 Kg/EACH 3.0 LBS/EACH

NOTES:

- VISIT OUR ON-LINE CATALOG AT [WWW.PANDUIT.COM](http://WWW.PANDUIT.COM) FOR A LIST OF CURRENT PARTS APPLICABLE FOR USE WITH THIS PRODUCT.
- PRIMARY DIMENSIONS ARE IN MILLIMETERS (mm).
- PARTS SUPPLIED:  
(2) - PDU BRACKETS  
(8) - TORX SCREWS  
(1) - INSTRUCTION SHEET

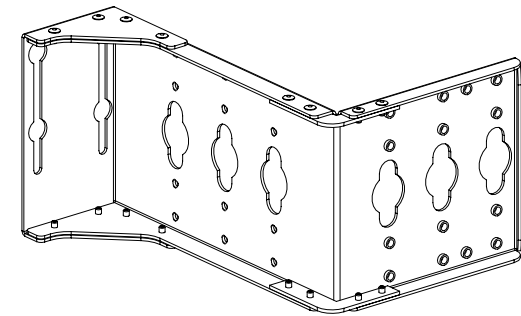

ISO VIEW

REV	DATE	BY	CHK	APR	DESCRIPTION	ECN
00A	11-3-15	LEE			RELEASED TO PRODUCTION	V09000NP

TITLE <b>N-TYPE PDU BRACKET (NVPDUB7018)</b>		CUSTOMER DRAWING	
ITEM REVISION NAME 11V223IC/01		<b>PANDUIT</b>	
DATASET FILE NAME 11V223IC_DC/01A			
DRAWN BY LEE		MATERIAL: N/A	
DATE 11-3-15		DRAWING NUMBER: 11V223IC-DC	
THIRD ANGLE PROJECTION		SHT 1 OF 2	
SCALE NONE	CHK	SIZE A	

D10100DA/16

2

1

2

1

THIS COPY IS PROVIDED ON A RESTRICTED BASIS AND IS NOT TO BE USED IN ANY WAY DETRIMENTAL TO THE INTERESTS OF PANDUIT CORP.

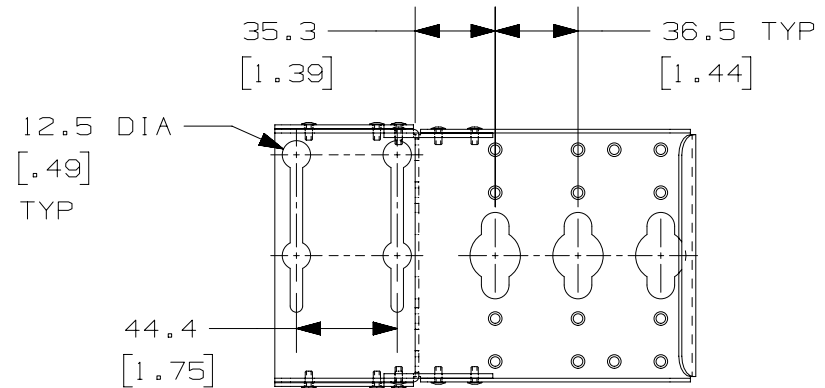
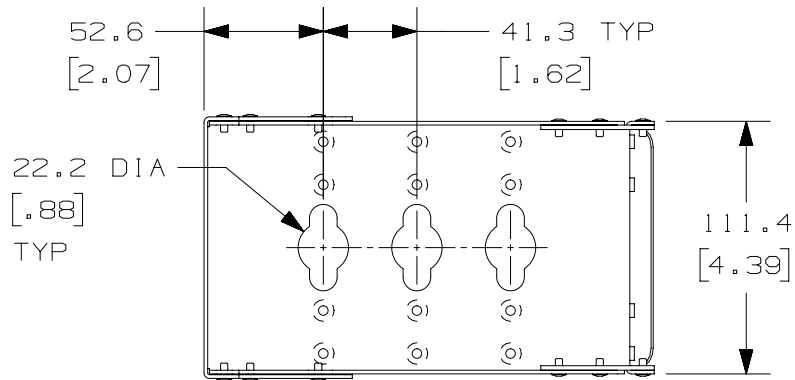
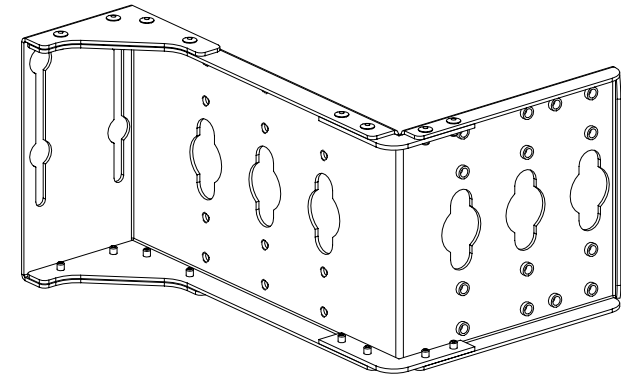
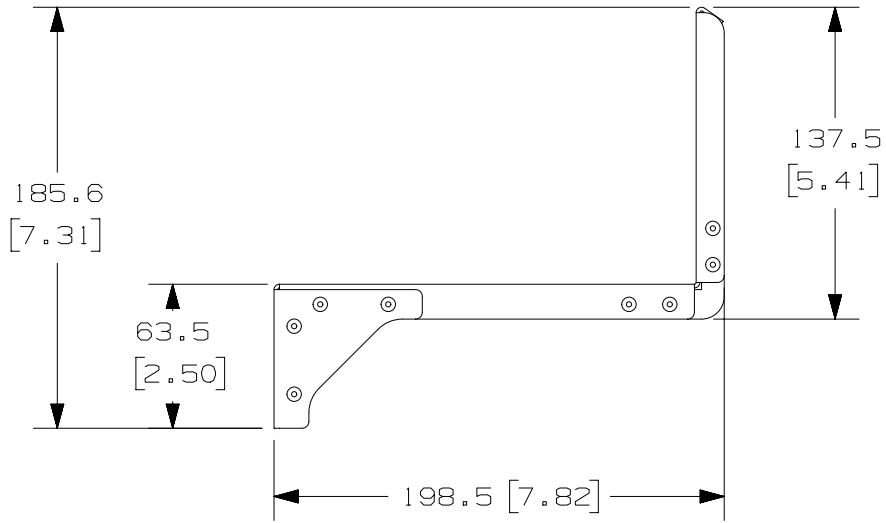

TITLE		N-TYPE PDU BRACKET (NVPDUB7018)	
CUSTOMER DRAWING			
ITEM REVISION NAME		11V223IC/01	
DATASET FILE NAME		11V223IC_DC/01A	
MATERIAL:		N/A	
DRAWING NUMBER:		11V223IC-DC	
DRAWN BY		LEE	
DATE		11-3-15	
CHK			
SCALE		NONE	
THIRD ANGLE PROJECTION			
SHT 2 OF 2		A	

00A	11-3-15	LEE		SEE SHEET 1 FOR REVISIONS	V09000NP	
REV	DATE	BY	CHK	APR	DESCRIPTION	ECN

D10100DA/16