



SES70-HN025AK22

SES/SEM

MOTOR FEEDBACK SYSTEMS ROTARY HIPERFACE®

SICK
Sensor Intelligence.



Illustration may differ



Ordering information

Type	Part no.
SES70-HN025AK22	1074671

Other models and accessories → www.sick.com/SES_SEM

Detailed technical data

Performance

Sine/cosine periods per revolution	32
Number of the absolute ascertainable revolutions	1
Total number of steps	1,024
Measuring step	10 " For interpolation of the sine/cosine signals with, e. g., 12 bits
Integral non-linearity	± 100 " ¹⁾
Differential non-linearity	± 55 " ¹⁾
Latency	25 µs
Available memory area	2,048 Byte
System accuracy	± 155 "

¹⁾ Typical values at nominal position ± 0.1 mm und +20 °C.

Interfaces

Type of code for the absolute value	Binary
Code sequence	Rising, For clockwise shaft rotation, looking in direction "A" (see dimensional drawing)
Communication interface	HIPERFACE®

Electrical data

Connection type	Male connector, 8-pin
Supply voltage	7 V DC ... 12 V DC
Warm-up time voltage ramp	Max. 180 ms ¹⁾
Recommended supply voltage	11 V DC
Current consumption	≤ 150 mA ²⁾
MTTF: mean time to dangerous failure	155 years (EN ISO 13849) ³⁾

¹⁾ Duration of voltage ramp between 0 and 7.0 V.

²⁾ At 7 V DC and without load.

³⁾ This product is a standard product and does not constitute a safety component as defined in the Machinery Directive. Calculation based on nominal load of components, average ambient temperature 60 °C, frequency of use 8760 h/a. All electronic failures are considered hazardous. For more information, see document no. 8015532.

Mechanical data

Shaft version	Through hollow shaft
Shaft diameter	25 mm
Dimensions	See dimensional drawing
Weight	≤ 0.13 kg
Moment of inertia of the rotor	60 gcm ²
Operating speed	8,500 min ⁻¹ , up to which the absolute position can be reliably produced
Angular acceleration	≤ 50,000 rad/s ²
Permissible radial shaft movement	± 0.15 mm
Permissible axial shaft movement	± 0.4 mm
Permissible movement static	± 0.3 mm
Permissible movement dynamic	± 0.1 mm

Ambient data

Operating temperature range	-30 °C ... +115 °C
Storage temperature range	-40 °C ... +125 °C, without package
Relative humidity/condensation	85 %, Condensation not permitted ¹⁾
Resistance to shocks	100 g, 10 ms (according to EN 60068-2-27) ²⁾
Frequency range of resistance to vibrations	50 g, 10 Hz ... 2,000 Hz (EN 60068-2-6) ¹⁾
EMC	According to EN 61000-6-2 and EN 61000-6-4 (Class A) ³⁾
Enclosure rating	IP40, with mating connector inserted and closed cover (IEC 60529)

¹⁾ More information can be found in the white paper (DE: 8021543/EN: 8021544).

²⁾ Every encoder has been tested with a half-sine-shaped shock.

³⁾ The EMC according to the standards quoted is achieved when the motor feedback system is mounted in an electrically conductive housing, which is connected to the central earthing point of the motor controller via a cable screen. If other shielding concepts are used, users must perform their own tests.

Classifications

eCI@ss 5.0	27270590
eCI@ss 5.1.4	27270590
eCI@ss 6.0	27270590
eCI@ss 6.2	27270590
eCI@ss 7.0	27270590
eCI@ss 8.0	27270590
eCI@ss 8.1	27270590
eCI@ss 9.0	27270590
eCI@ss 10.0	27273805
eCI@ss 11.0	27273901
eCI@ss 12.0	27273901
ETIM 5.0	EC001486
ETIM 6.0	EC001486
ETIM 7.0	EC001486
ETIM 8.0	EC001486
UNSPSC 16.0901	41112113

Dimensional drawing (Dimensions in mm (inch))

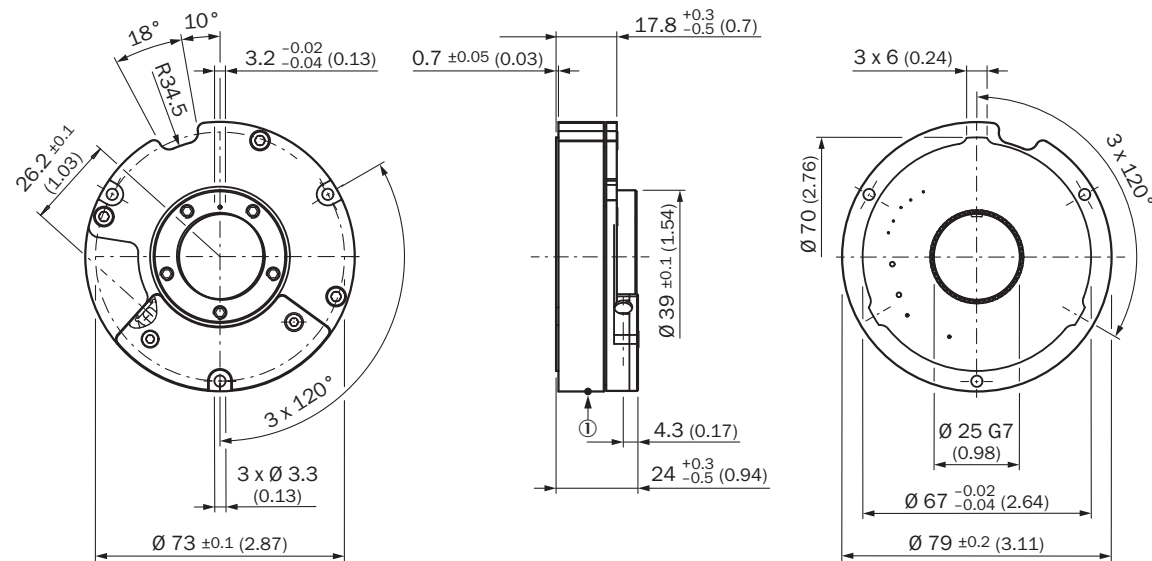

① Measuring point for operating temperature

Attachment specifications

Attachment specifications

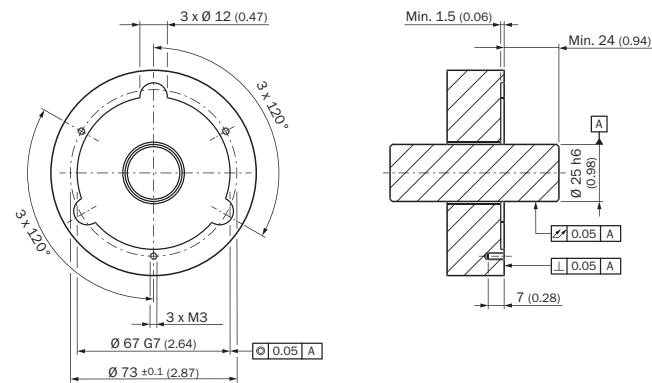

Read-out axial position: Negative number shows the movement of the robot away from the motor flange; positive number shows movement of the rotor towards the motor flange

PIN assignment

View of the plug-in face

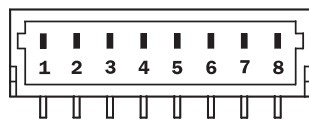

PIN	Signal	Wire colors (cable connection)	Explanation
1	U _S	Red	Supply voltage
2	+ SIN	White	Process data channel

PIN	Signal	Wire colors (cable connection)	Explanation
3	REFSIN	Brown	Process data channel
4	+ COS	Pink	Process data channel
5	REFCOS	Black	Process data channel
6	GND	Blue	Ground connection
7	Data +	Gray or yellow	Parameter channel RS 485
8	Data -	Green or purple	Parameter channel RS 485
The GND connection (0 V) of the supply voltage is not connected to the housing			

SICK AT A GLANCE

SICK is one of the leading manufacturers of intelligent sensors and sensor solutions for industrial applications. A unique range of products and services creates the perfect basis for controlling processes securely and efficiently, protecting individuals from accidents and preventing damage to the environment.

We have extensive experience in a wide range of industries and understand their processes and requirements. With intelligent sensors, we can deliver exactly what our customers need. In application centers in Europe, Asia and North America, system solutions are tested and optimized in accordance with customer specifications. All this makes us a reliable supplier and development partner.

Comprehensive services complete our offering: SICK LifeTime Services provide support throughout the machine life cycle and ensure safety and productivity.

For us, that is “Sensor Intelligence.”

WORLDWIDE PRESENCE:

Contacts and other locations –www.sick.com