

TECHNICAL DATA

CABLE GLAND TYPE : T3CDS / T3CDSPB
 INGRESS PROTECTION : IP66, NEMA 4X, DELUGE TO DTS01-01
 PROCESS CONTROL SYSTEM : BS EN ISO 9001
 : ISO / IEC 80079-34:2011

HAZARDOUS AREA CLASSIFICATION

ATEX CERTIFICATION No : SIRA 06ATEX1283X & SIRA 06ATEX4328X
 ATEX CERTIFICATION CODE : II 2 GD Ex d IIC / Ex e II / Ex nR II / Ex tD A21 IP66
 IEC Ex CERTIFICATION No : IEC Ex SIR.07.0005X
 IEC Ex CERTIFICATION CODE : Ex d IIC / Ex e II / Ex nR II / Ex tD A21 IP66
 CSA CERTIFICATION No : CSA.02.310517X
 CSA CERTIFICATION CODE : Class I Div 2 Gp, A, B, C, D; Class II Div 2 Gp E, F, G; Class III
 UL CERTIFICATION FILE : E200163, E256367
 UL CERTIFICATION CODE : Class I, Zone 1, AEx e II; TYPE 4X, OIL RES II

INSTALLATION INSTRUCTIONS

Installation should only be performed by a competent person using the correct tools. Spanners should be used for tightening. Read all instructions before beginning installation.

SPECIAL CONDITIONS FOR SAFE USE

- The glands ranges shall only be used on enclosures where the temperature, at the point of mounting, is in the range -60°C to +130°C.
- When used with braided cable, the cable glands shall be used for fixed installations only. Cables must be effectively clamped to prevent twisting and pulling.
- When used in Group I applications, the equipment must only be mounted where the risk of mechanical impact is low.

ACCESSORIES

The following accessories are available from CMP Products, as optional extras, to assist with fixing, sealing and earthing :-
 Locknut | Earth Tag | Serrated Washer | Entry Thread (I.P.) Sealing Washer

Cable Gland Selection Table

Cable Gland Size	Available Entry Threads			Thread Length metric	Cable Bedding Diameter		Overall Cable Diameter		Armour Wire Diameter				Across Flats Max	Across Corners Max	Protrusion Length	Ordering Reference (Brass Metric) **	Cable Gland Weight (Kgs)
	Standard		Option		Min	Max	Min*	Max	Grooved Cone		Stepped Cone						
	Metric	NPT	NPT						Min	Max	Min	Max					
20S/16	M20	1/2"	3/4"	15.0	3.2	8.7	6.1	13.4	0.15	0.5	0.9	1.0	24.0	25.9	70.0	20S16T3CDS1RA	0.170
20S	M20	1/2"	3/4"	15.0	6.1	11.7	9.5	15.9	0.15	0.5	0.9	1.25	24.0	25.9	70.0	20ST3CDS1RA	0.170
20	M20	1/2"	3/4"	15.0	6.5	14.0	12.5	20.9	0.2	0.5	0.9	1.25	30.5	32.9	72.0	20T3CDS1RA	0.256
25S	M25	3/4"	1"	15.0	11.1	20.0	14.0	22.0	0.2	0.6	1.25	1.6	37.5	40.5	82.0	25ST3CDS1RA	0.384
25	M25	3/4"	1"	15.0	11.1	20.0	18.2	26.2	0.2	0.6	1.25	1.6	37.5	40.5	82.0	25T3CDS1RA	0.379
32	M32	1"	1 1/4"	15.0	17.0	26.3	23.7	33.9	0.2	0.6	1.6	2.0	46.0	49.7	85.0	32T3CDS1RA	0.560
40	M40	1 1/4"	1 1/2"	15.0	23.5	32.2	27.9	40.4	0.2	0.8	1.6	2.0	55.0	59.4	86.0	40T3CDS1RA	0.848
50S	M50	1 1/2"	2"	15.0	31.0	38.2	35.2	46.7	0.2	0.8	2.0	2.5	60.0	64.8	98.0	50ST3CDS1RA	1.055
50	M50	2"	2 1/2"	15.0	35.6	44.1	40.4	53.1	0.3	0.8	2.0	2.5	70.0	75.6	100.0	50T3CDS1RA	1.521
63S	M63	2"	2 1/2"	15.0	41.5	50.0	45.6	59.4	0.3	0.8	2.0	2.5	75.0	81.0	108.0	63ST3CDS1RA	1.750
63	M63	2 1/2"	3"	15.0	47.2	56.0	54.6	65.9	0.3	0.8	2.0	2.5	80.0	86.4	103.0	63T3CDS1RA	1.685
75S	M75	2 1/2"	3"	15.0	54.0	62.0	59.0	72.1	0.3	0.8	2.0	2.5	89.0	96.1	105.0	75ST3CDS1RA	2.345
75	M75	3"	3 1/2"	15.0	61.1	68.0	66.7	78.5	0.3	0.8	2.0	2.5	99.0	106.9	114.0	75T3CDS1RA	3.200
90	M90	3"	3 1/2"	24.0	66.6	79.3	76.2	90.4	0.4	0.8	3.15	3.15	114.0	123.1	140.0	90T3CDS1RA	5.100
100	M100	4"	4 1/2"	24.0	76.0	91.0	86.1	101.5	0.4	0.8	3.15	4.0	123.0	132.8	170.0	100T3CDS1RA	6.500
115	M115	4 1/2"	5"	24.0	86.0	98.0	101.5	110.3	0.4	0.8	3.15	4.0	133.4	144.1	210.0	115T3CDS1RA	7.000
130	M130	5"	6"	24.0	97.0	115.0	114.2	123.3	0.4	0.8	3.15	4.0	146.1	157.8	250.0	130T3CDS1RA	7.800

Dimensions are displayed in millimetres unless otherwise stated

** Insert "PB" into the code for T3CDSPB glands e.g. 20T3CDSPB1RA
 * For IP67 & IP68 requirements the Overall Cable Diameter (minimum value) shown above should be increased by 1.0 mm to ensure complete compliance

I, The undersigned, hereby declare that the equipment referred to herein conforms to the requirements of the ATEX Directive 94/9/EC and the following standards:-

EN60079-0:2006, EN60079-1:2007, EN60079-7:2007, EN60079-15:2005, BS 6121:1989, EN50262:1989 (Amd 2001), EN61241-0:2004, EN61241-1:2004

G. I. Mood

Dr Geof Mood - Technical Director - (Authorised Person)

Glasshouse Street • St. Peters • Newcastle upon Tyne • NE6 1BS
 Tel: +44 191 265 7411 • Fax: +44 191 265 0581
 E-Mail: cmp@cmp-products.co.uk • Web: www.cmp-products.com



CE 0518

Notified Body: Sira Certification Service, Rake Lane, Chester CH4 9JN, England.

www.cmp-products.com

INSTALLATION INSTRUCTIONS FOR CMP CABLE GLAND TYPES T3CDS & T3CDSPB

CABLE GLAND FOR USE WITH SINGLE WIRE ARMOUR (SWA), WIRE BRAID, STRIP, AND TAPE ARMOUR (T3CDSPB VERSION CAN ALSO BE USED ON CABLE WITH A LEAD SHEATH).
 FOR USE IN HAZARDOUS LOCATIONS.

INCORPORATING EC DECLARATION OF CONFORMITY TO DIRECTIVE 94/9/EC

**CMP TRITON™ CDS™ DELUGE PROOF CABLE GLAND FEATURING
 COMPENSATING DISPLACEMENT SEAL SYSTEM.**

CABLE GLAND TYPES T3CDS & T3CDSPB



LISTED MARINE SHIPBOARD
 CABLE FITTING
 31YM
 29NX



INSTALLATION INSTRUCTIONS FOR CMP CABLE GLAND T3CDS & T3CDSPB

CABLE GLAND COMPONENTS

1. Entry Item
2. Body
3. Compensating Sleeve
4. Reversible Armour Cone
5. AnyWay Clamping Ring
6. Outer Seal Nut

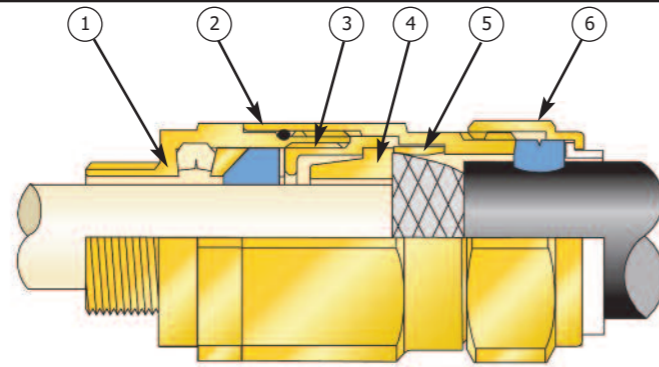

PLEASE READ ALL INSTRUCTIONS CAREFULLY BEFORE BEGINNING THE INSTALLATION

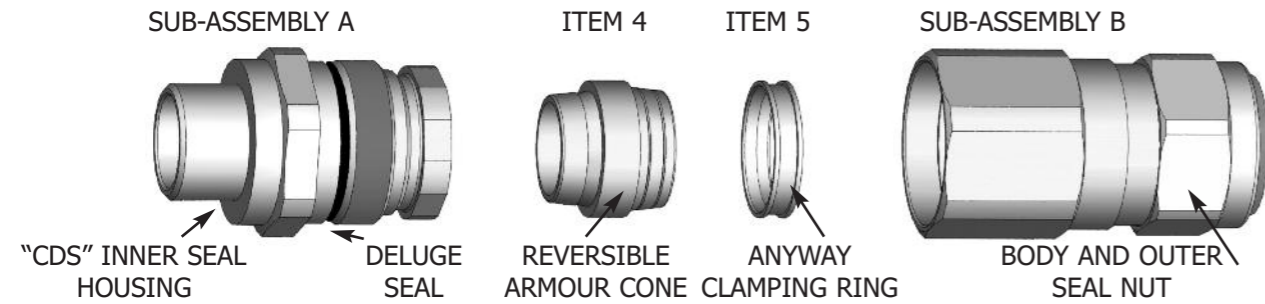

1. Separate the gland into two sub-assemblies, A and B, by unscrewing the body (2) from the entry item (1). Note that items (4) and (5) are loose items.

2. Prepare the cable by stripping back the cable outer sheath and armour to suit the equipment geometry. Expose the armour by stripping back the outer sheath further using the table below as a guide.

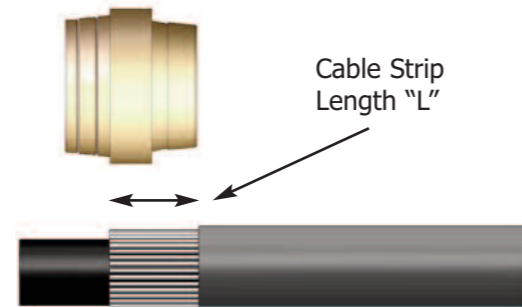

CABLE GLAND SIZE	20S/16, 20S, 20	25S, 25, 32, 40	50S, 50, 63S, 63	75S, 75, 90, 100, 115, 130
CABLE STRIP LENGTH "L"	12mm	15mm	18mm	20mm

3. Secure the entry components (sub-assembly A) into the equipment. **(Not for remote installation)** Pass the sub-assembly B (outer seal first) and AnyWay clamping ring (5) over the cable. Insert the reversible armour cone (4) in the sub-assembly A, orientation to suit cable (see below)

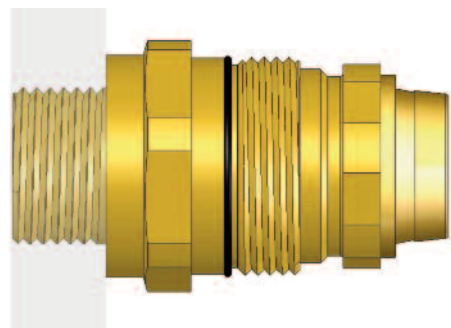

Grooved side of cone outwards - to terminate braid, strip armour, pliable wire or tape armour.

Stepped side of cone outwards - to terminate SWA cable.

4. Pass the cable through sub-assembly A, spacing the armour or braid evenly around the cone. Whilst continuing to push the cable forward to keep the cable braid or armour in contact with the cone, tighten the compensating sleeve (3) into the entry component (1) until all the threads are used. (Note that the internal compensator will prevent the cable gland inner seal from being over-tightened onto the cable inner sheath.)
 The inner sheath of the T3CDSPB gland contains a device to automatically make an electrical contact with the lead sheath on the cable as the cable is installed.

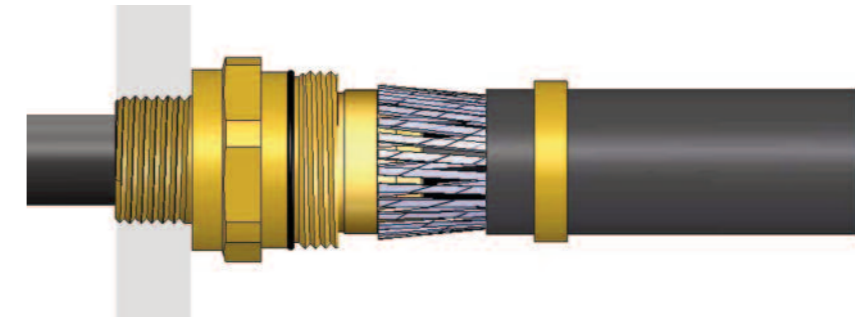

5. Terminate the cable by tightening the body (2) onto the entry component (1) using a spanner on each part. Tighten the body until the body and entry components are metal to metal and cannot be tightened further.

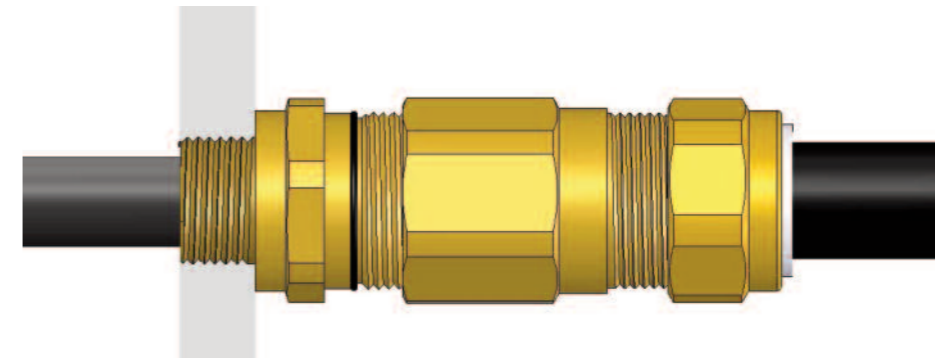

6. Tighten the outer seal nut (6) until it comes to an effective stop. This will occur when:-
 A) The outer seal nut (6) has clearly engaged the cable and cannot be further tightened without the use of excessive force by the installer.
 B) The outer seal nut (6) is metal to metal with the body of the gland (2).

