

TeSys[®] ULULC032-033 Modbus Communication Module

User's Manual

03/2009

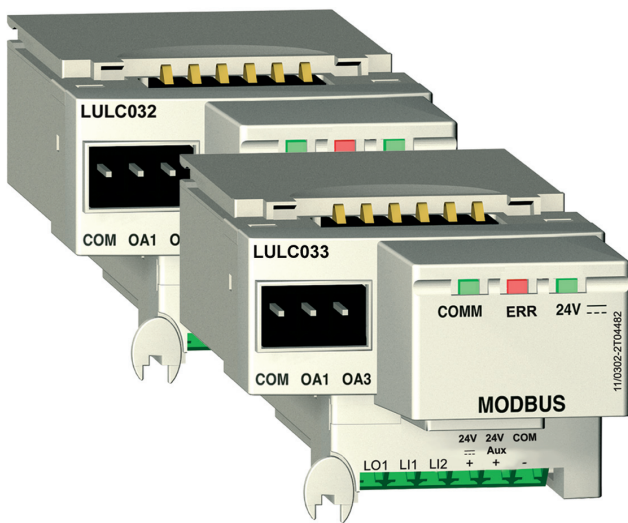

Schneider Electric assumes no responsibility for any errors that may appear in this document. If you have any suggestions for improvements or amendments or have found errors in this publication, please notify us.

No part of this document may be reproduced in any form or by any means, electronic or mechanical, including photocopying, without express written permission of Schneider Electric.

All pertinent state, regional, and local safety regulations must be observed when installing and using this product. For reasons of safety and to help ensure compliance with documented system data, only the manufacturer should perform repairs to components.

When devices are used for applications with technical safety requirements, the relevant instructions must be followed.

Failure to use Schneider Electric software or approved software with our hardware products may result in injury, harm, or improper operating results.

Failure to observe this information can result in injury or equipment damage.

© 2009 Schneider Electric. All rights reserved.

Table of Contents



	Safety Information	5
	About the Book	7
Part I	Hardware Implementation	9
Chapter 1	Installing the LULC032-033 Modbus Module	11
	Safety Instructions	12
	Presentation of the LULC032-033 Modbus Communication Module	13
	Description of the Module and Installation	15
	Electrical Connection	18
	Connection to the RS485 Bus	23
Chapter 2	Technical Characteristics	31
	Conditions of Use and Technical Characteristics	32
	Replacing an LULC031 Module with an LULC032-033 Module	35
Part II	Software Implementation	39
Chapter 3	Starting up the Module via the Registers	41
	General Information on Start-up via the Registers	42
	Data-Exchange Format	43
	Factory Configuration	45
	Customizing Your Configuration	46
	Modbus Requests and Programming Examples	52
	Use of the Main Registers for Simplified Management	53
Chapter 4	Fault and Warning Management	55
	Displaying Faults	56
	Application Faults	57
	Warnings - Loss of Communication	58
	Internal Faults	59
Chapter 5	Configuration of Predefined Functions	61
	Description of Reflex Stop Functions	62
	Use of Reflex1 and Reflex2	64
Index	65

Safety Information

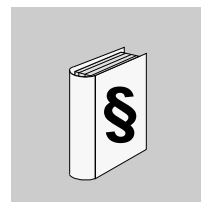

Important Information

NOTICE

Read these instructions carefully, and look at the equipment to become familiar with the device before trying to install, operate, or maintain it. The following special messages may appear throughout this documentation or on the equipment to warn of potential hazards or to call attention to information that clarifies or simplifies a procedure.



The addition of this symbol to a Danger or Warning safety label indicates that an electrical hazard exists, which will result in personal injury if the instructions are not followed.



This is the safety alert symbol. It is used to alert you to potential personal injury hazards. Obey all safety messages that follow this symbol to avoid possible injury or death.

DANGER

DANGER indicates an imminently hazardous situation which, if not avoided, **will result in** death or serious injury.

WARNING

WARNING indicates a potentially hazardous situation which, if not avoided, **can result in** death or serious injury.

CAUTION

CAUTION indicates a potentially hazardous situation which, if not avoided, **can result in** minor or moderate injury.

CAUTION

CAUTION, used without the safety alert symbol, indicates a potentially hazardous situation which, if not avoided, **can result in** equipment damage.

PLEASE NOTE

Electrical equipment should be installed, operated, serviced, and maintained only by qualified personnel. No responsibility is assumed by Schneider Electric for any consequences arising out of the use of this material.

A qualified person is one who has skills and knowledge related to the construction and operation of electrical equipment and the installation, and has received safety training to recognize and avoid the hazards involved.

About the Book

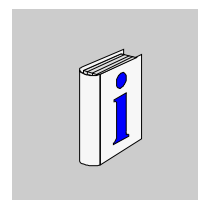

At a Glance

Document Scope

This Manual describes the implementation, functions and operation of the LULC032-033 Modbus communication module.

Area of application: mainly control system applications in the Industry and Building sectors.

Validity Note

Firmware version compatibility:

Product versions				
	LULC03•	LUTM	LUCM	LUCMT
LULC032	V1.1	V1.1	---	V2.06
	V1.2	V1.2*	---	V2.10*
	V1.3	V1.2*	---	V2.11*
LULC033	V2.2	V1.2*	V1.10*	V2.11*

* and later versions.

Related Documents

Title of Documentation	Reference Number
LULC033 Modbus Module - Instruction Sheet	1743239
LU9GC3 Modbus Tap Module - Instruction Sheet	1638860
TeSys U Communication Variables - User's Manual	1744082
LU•B/LU•S• TeSys U Starters - Instruction Sheet	1629984
LUTM• TeSys U Controller - User's Manual	1743233
LUTM• TeSys U Controller - Instruction Sheet	1743236
LUCM/LUCMT Multifunction Control Units - User's Manual	1743237
LUCM/LUCMT/LUCBT/LUCDT Control Units - Instruction Sheet	AAV40504
LUCA/LUCB/LUCC/LUCD Control Units - Instruction Sheet	AAV40503
Electromagnetic Compatibility - Practical Installation Guidelines	DEG999
Modbus Over Serial Line, Specification & Implementation Guide	Modbus_over_serial_line_V1

You can download these technical publications and other technical information from our website at www.schneider-electric.com.

User Comments

We welcome your comments about this document. You can reach us by e-mail at techcomm@schneider-electric.com.

Hardware Implementation

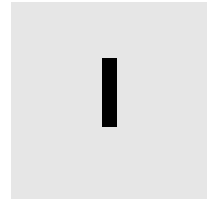

Introduction

This section describes the LULC032-033 Modbus communication module installation and technical characteristics.

What's in this Part?

This part contains the following chapters:

Chapter	Chapter Name	Page
1	Installing the LULC032-033 Modbus Module	11
2	Technical Characteristics	31

Installing the LULC032-033 Modbus Module

1

Introduction

This chapter introduces the LULC032-033 Modbus communication module and describes the various steps involved in the physical installation of the product.

What's in this Chapter?

This chapter contains the following topics:

Topic	Page
Safety Instructions	12
Presentation of the LULC032-033 Modbus Communication Module	13
Description of the Module and Installation	15
Electrical Connection	18
Connection to the RS485 Bus	23

Safety Instructions

General Instructions

 CAUTION
--

HAZARDOUS OPERATION

These devices must be installed, configured and used by qualified staff only.

Users must follow all current instructions, standards and regulations.
--

Check the function settings before starting the motor.
--

Do not downgrade or modify these devices.

Failure to follow these instructions can result in injury or equipment damage.

 CAUTION
--

PRECAUTIONS WHEN USING COMMUNICATION VARIABLES

Only use the serial link for transmitting data that is not critical to the application.

There is some delay in the transmission of data relating to motor-starter states and load-current values. This data must not therefore be used in the management of safety devices and emergency stops.

Data such as Forward, Reverse and Stop must not be used in safety and emergency-stop circuits.
--

Failure to follow these instructions can result in injury or equipment damage.

Presentation of the LULC032-033 Modbus Communication Module

Receiving the Product

On opening the box containing the LULC032-033 Modbus communication module, you should find the following items:

- An Instruction Sheet (IS), providing brief pictorial information about the standard installation of the module
- An LULC032-033 Modbus communication module with connectors.

NOTE: Check that you actually have all the items described above. Make sure that the Quick Reference Guide is included, along with the correctly inserted connectors.

Functions offered

The communication module is used to control a motor-starter remotely, via Modbus, from:

		LULC032	LULC033
TeSys U starter-controller	LUB**/LU2B**		√
TeSys U starter	LUS**/LU2S**		√
TeSys U controller	LUTM**	√	√

NOTE: Modbus LULC032 communication modules should be used exclusively with LUTM10BL or LUTM20BL controllers.

Using the communication module, you can:

- Read the motor-starter states
- Control the motor-starter (reversing or non-reversing)
- Adjust the protection functions
- Read the data processed in the advanced and multifunction control units
- Read the state of the I/O (controller base)

DANGER

CONTROL VOLTAGE

The LULC032 Modbus communication module must only be used with 24 V control units (LUC***BL).

Failure to follow these instructions will result in death or serious injury.

NOTE: For information on the Modbus protocol, please refer to the following website: www.Modbus.org.

Data Available

The available protection and control data depend on the control unit with which the Modbus communication module is used.

There are 3 types of control unit:

- Standard (reference LUCA)
- Advanced (references LUCB/C/D, LUCBT/DT)
- Multifunction (references LUCM/MT)

The table below can be used to check the data and commands you can access with each type of control unit:

Data - Commands	Control unit		
	Standard (LUCA)	Advanced (LUCB/C/D, LUCBT/DT)	Multifunction (LUCM/MT)
Start and stop commands	√	√	√
Status (ready, running, fault condition)	√	√	√
Warning		√	√
Automatic reset and remote reset via the bus		√	√
Indication of the motor load		√	√
Differentiation of faults		√	√
Remote parameter setting and viewing of all functions			√
'Log' function			√
'Monitoring' function			√

Description of the Module and Installation

Diagram of the Module

Connectors and indicator lights (LEDs) on the LULC032-033 Modbus communication module :

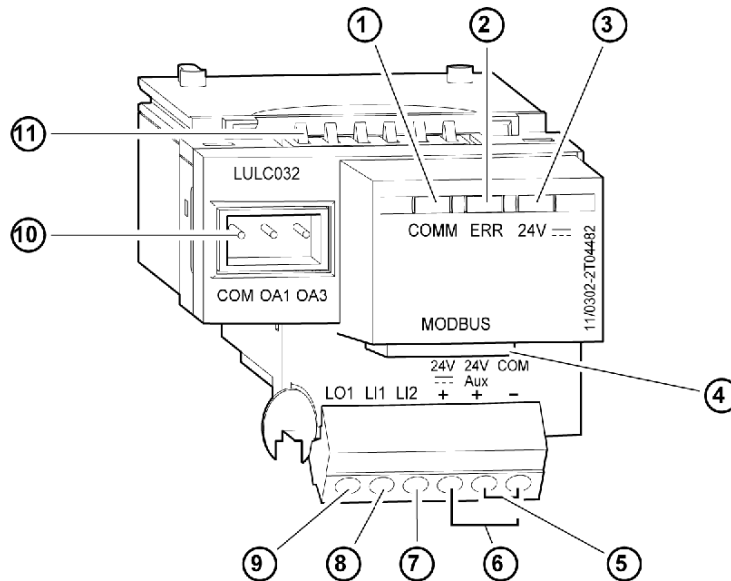

NOTE: The pinout differs from that on the LULC031 Modbus communication module.

- 1 Green "COMM" Modbus communication status LED.
- 2 Red "ERR" Modbus communication module fault indication LED.
- 3 Green "24V ---" LED indicating voltage presence at outputs OA1, OA3, LO1.
- 4 RJ45 connector for the Modbus RS485 link.
- 5 Connection of the module power supply.
- 6 Connection of the 24 V --- power supply for outputs OA1, OA3, LO1.
- 7 Discrete input 2.
- 8 Discrete input 1.
- 9 Discrete output 1, assignable depending on the configuration register (685 LSB).
- 10 24 V --- prewired coil connector for the power base.
 - The assignment of OA1 depends on the configuration register (686 LSB).
 - The assignment of OA3 depends on the configuration register (686 MSB).
- 11 Connector for communication with the advanced or multifunction control unit.

Description of Indicator Lights (LEDs)

Description of the various states of the indicator lights (light-emitting diodes, LEDs) on the LULC032-033 Modbus communication module.

Light-emitting diodes (LEDs)			Meaning
Green "COMM" LED	Red "ERR" LED	Green "24V ---" LED	
Flashing (alternately with the "ERR" LED)	Flashing (alternately with the "COMM" LED)	On	Bus parameter initialization in progress
Flashing during communication with the Module address	Off	On	Normal operation
Off	Off	Off	Faulty: 24 V DC voltage missing on the 24 V DC terminal. Check the connection between the power supply and the communication module.
	On	On	Internal fault on the LULC032-033 <i>Internal Faults, page 59</i>
	Flashing	On	Loss of communication on the Modbus network

NOTE: During startup, because the default fallback mode is "forced stop", if no communication has previously been established, the red "ERR" LED will flash after one minute (default timeout value).

Addressing Using Switches

The Modbus communication module address is defined by switches located on the underside of the module. Simply turn the module over to access them:

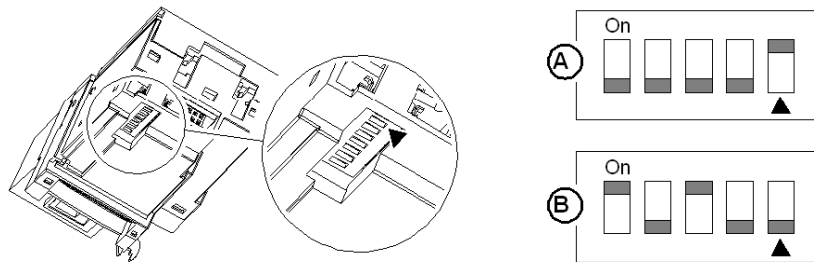

A) Le module est livré d'usine avec l'adresse 1.

B) Exemple de configuration pour l'adresse 20.

The range of accepted values is between 1 and 31.

The address coding is in binary format.

The **least significant bit** is on the right, indicated by ▲.

Address 0 is not taken into account by the module, since it is used by the Master for a broadcast request.

Caution: Address selection differs from that on the LULC031 Modbus communication module.

NOTE: Addressing is only taken into account when the communication module is powered up.

Order of Mounting on a Base

The LULC032 module is installed in a controller base, the LULC033 module is installed in a power base or a controller base (on the underside of the control unit which locks it in position).

To install the module in the power base or controller base:

Step	Action
1	Choose the prewired coil connection terminals.
2	Insert the LULC032-033 Modbus communication module.
3	Insert the control unit which locks the module.

The diagram below illustrates these steps. Installation of the LULC032-033 Modbus communication module corresponds to step (2). The numbers indicate both the order of mounting for the components and their location.

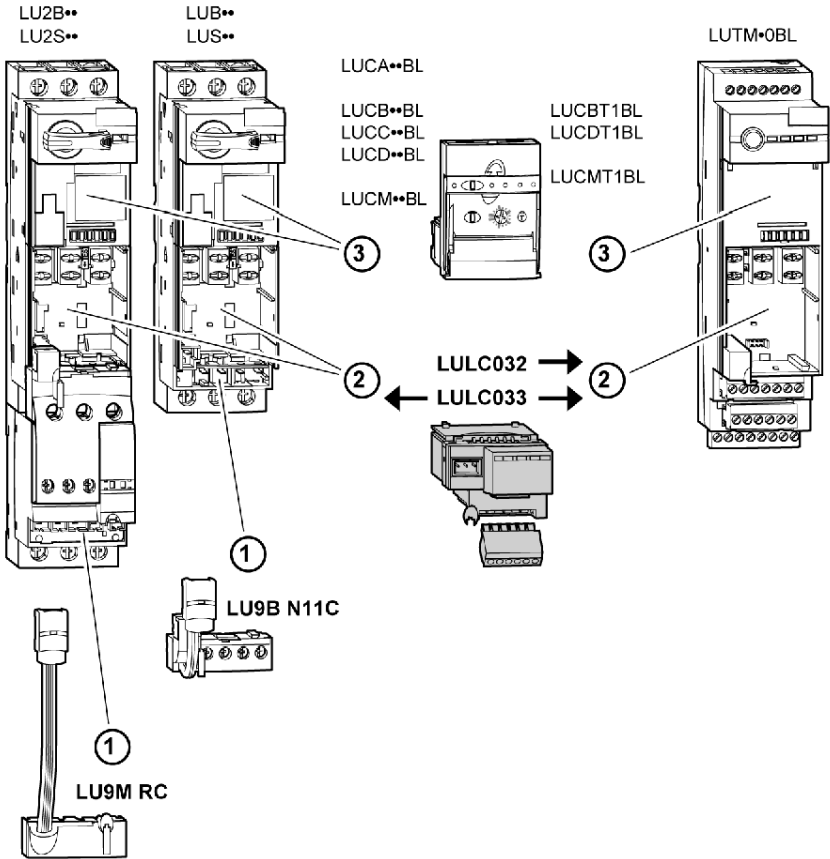

Electrical Connection

24 V $\overline{\text{---}}$ and 24 V Aux Power Supply

Diagram for 24 V $\overline{\text{---}}$ and 24 V Aux power supplies.

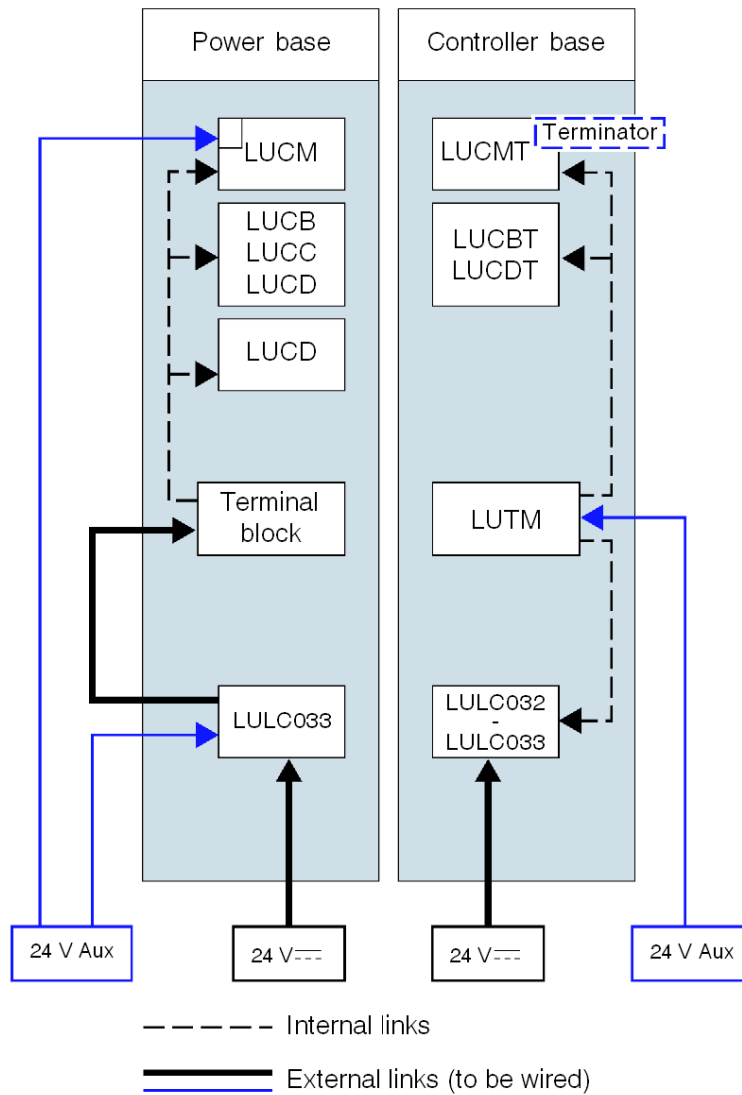

Power-up with an LUCM Multifunction Control Unit

LUCM and Power Base

The power-supply source must be the same for the LULC032-033 Modbus communication module and the LUCM multifunction control unit.

It is essential that the LUCM multifunction control unit and the LULC032-033 Modbus communication module are powered up simultaneously. Indeed, monitoring of the internal dialog between the LUCM and the LULC032-033 will produce two error messages depending on the order in which these objects were powered up.

When the A1-A2 terminals are not yet powered up (24V $\overline{\text{---}}$), there are 3 possible scenarios for powering up the **24V Aux**:

Powering up the LUCM ...	Powering up the LULC032-033 ...	Comment
Simultaneously		Recommended
1st	2nd	The " M15 " fault is displayed. This only occurs when the LULC032-033 Modbus communication module has already been used with the LUCM multifunction control unit.
2nd	1st	The LUCM control unit is identified by the LULC032-033 Modbus communication module when the 24 V Aux for the LULC032-033 Modbus communication module is switched on. If the 24 V Aux for the LUCM control unit is switched on for longer than twice the duration of the timeout (i.e., more than 1 s), the " M101 " fault is displayed (register 451, communication module internal faults).

NOTE: Both these faults are reset by powering down and then powering up the LULC032-033 Modbus communication module (power cycle) and the LUCM control unit.

LUCM and Controller Base

The 24 V $\overline{\text{---}}$ module power supply is provided by the LUTM controller.

Power Supply for the LULC032 and Outputs OA1, OA3 and LO1

In order to operate, the LULC032-033 Modbus communication module must be powered by a 24 V \equiv source:

- With a power base, the LULC033 must be powered by an external source.
- With a controller base, the LULC032 or LULC033 is powered directly.

Power Supply for LUB/LUS** /LU2B**/LU2S** Power Bases**

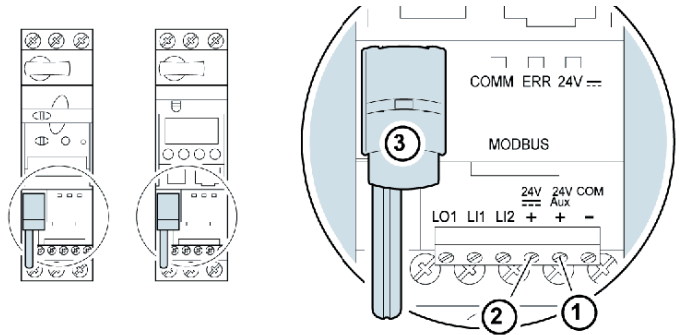

- 1 24 V Aux: Power-supply terminal for the LULC033 Modbus communication module.
- 2 24 V \equiv : Power-supply terminal for outputs OA1 OA3 and LO1.
- 3 Prewired link for connecting outputs OA1 and OA3 to terminals A1/A3/A2 on the starter.

Power Supply for an LUTM Controller Base

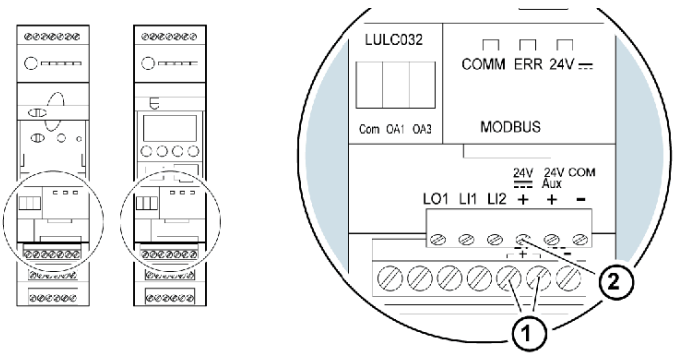

- 1 24 V \equiv : Power-supply terminals for the LUTM and the LULC032-033 Modbus communication module via an internal link.
- 2 The 24 V \equiv power supply for the LULC032-033 Modbus communication module is only required when using outputs OA1, OA3 and LO1.

Power Base: Terminal Power Supply

The user has two options for connecting the **power-base** terminals:

- Power supply via the LULC033 Modbus communication module with a prewired link
- Direct power supply with a wire-to-wire link

Prewired Link

Catalog numbers for the two prewired coils:

Designation	With a power base	Catalog number
Prewired coil	LUB**/LUS**	LU9B N11C
	LU2B**/LU2S**	LU9M RC

Illustration for both types of power base:

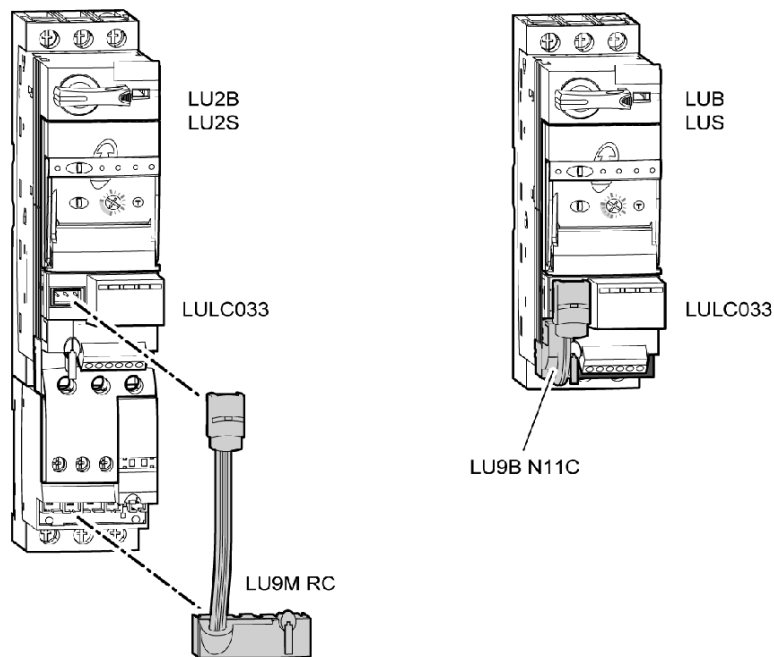

Wire-to-Wire Link (Power Supply to Outputs OA1, OA3 and LO1)

This type of link is compulsory in the case of a reversing starter-controller created from an LU6M reversing unit, for separate assembly.

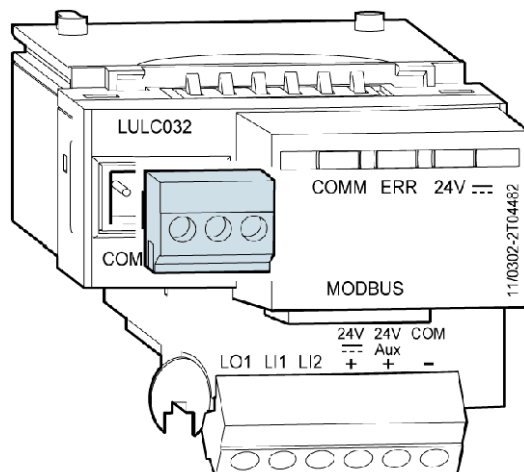

The wire-to-wire link can also be used to insert a local or external stop command, for example.

Connection Capacities of the LULC032-033 Terminals

The table below shows the conductor cross-sections to be used:

Connection	Type of conductor	Cross-section (min. - max.)	
1 conductor	Solid conductor	0.14 ... 1 mm ²	AWG 26 ... AWG 18
	Stranded conductor	0.14 ... 1 mm ²	AWG 26 ... AWG 18
	Stranded conductor with cable end: - Non-insulated - Insulated	0.25 ... 1 mm ²	AWG 24 ... AWG 18
		0.25 ... 0.5 mm ²	AWG 24 ... AWG 20
2 conductors (same cross-section)	2 solid conductors	0.14 ... 0.5 mm ²	AWG 26 ... AWG 20
	2 stranded conductors	0.14 ... 0.75 mm ²	AWG 26 ... AWG 20
	2 stranded conductors with cable end: - Non-insulated - Insulated	0.25 ... 0.34 mm ²	AWG 24 ... AWG 22
		0.50 mm ²	AWG 20

Connectors	3 and 6 pts	
Increment	3.81 mm	0.15 in.
Tightening torque	0.2/0.25 N.m.	28.3/35.4 lb-in.
Flat screwdriver	2.5 mm	0.10 in.

Connection to the RS485 Bus

General

There are several ways in which the user can connect the communication module to the RS 485 bus:

- Direct connection to the bus via a VW3A8306TF•• T-junction box
- Connection to the bus via a splitter box
- Connection to the bus via SCA type junction boxes

For Interference Protection:

Use the Schneider Electric cable with 2 pairs of shielded twisted conductors (references: TSXCSA100, TSXCSA200, TSXCSA500, VW3A8306TF••).

Keep the Modbus cable away from the power cables (at least 30 cm).

Create crossovers of the Modbus cable and the power cables at right-angles, if necessary.

NOTE: For more information, consult guide TSX DG KBL F: "Electromagnetic Compatibility of Industrial Networks and Fieldbuses".

The RS 485 standard allows variants of some characteristics:

- Polarization
- Line terminator
- Number of slaves
- Length of bus

The new Modbus specification, published in 2002 on the Modbus.org site, defines all these characteristics precisely. All new Schneider Electric devices conform to this specification.

Connection to the Bus via a Tee

The standard diagram corresponds to the Modbus specification published in 2002 on the Modbus.org site (Modbus_over_serial_line_V1.pdf, Nov 2002) and in particular to the 2-wire multidrop serial bus diagram.

The LULC032-033 Modbus communication module conforms to this specification.

The simplified diagram is as follows:

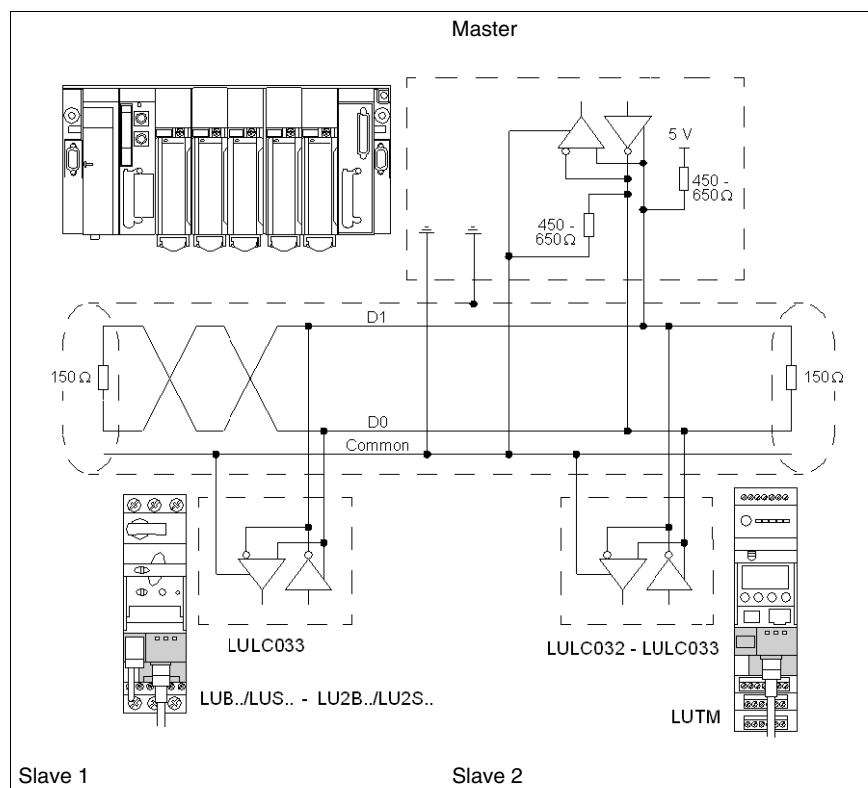

The characteristics for direct connection to the bus are as follows:

Designation	Description
Type of trunk cable	Single shielded twisted pair cable and at least a 3rd conductor
Maximum length of bus	1000 m at 19,200 bps with the Schneider Electric TSX CSA•• cable
Maximum number of stations (without repeater)	32 stations, i.e., 31 slaves
Maximum length of tap-offs	<ul style="list-style-type: none"> • 20 m for one tap-off • 40 m divided by the number of tap-offs on the multiple junction box
Bus polarization	<ul style="list-style-type: none"> • A 450 to 650 ohm pulldown resistor at the 5 V • A 450 to 650 ohm pulldown resistor at the Common <p>This polarization is recommended for the master. There is no polarization at the RS 485 terminal on the communication module.</p>
Line terminator	A 150 ohm resistor +/- 5%
Common polarity	Yes (Common), connected to the protective ground in at least one point on the bus

Connection to the Bus via a Splitter Box

The connection diagram for connection to the bus via a splitter box is as follows:

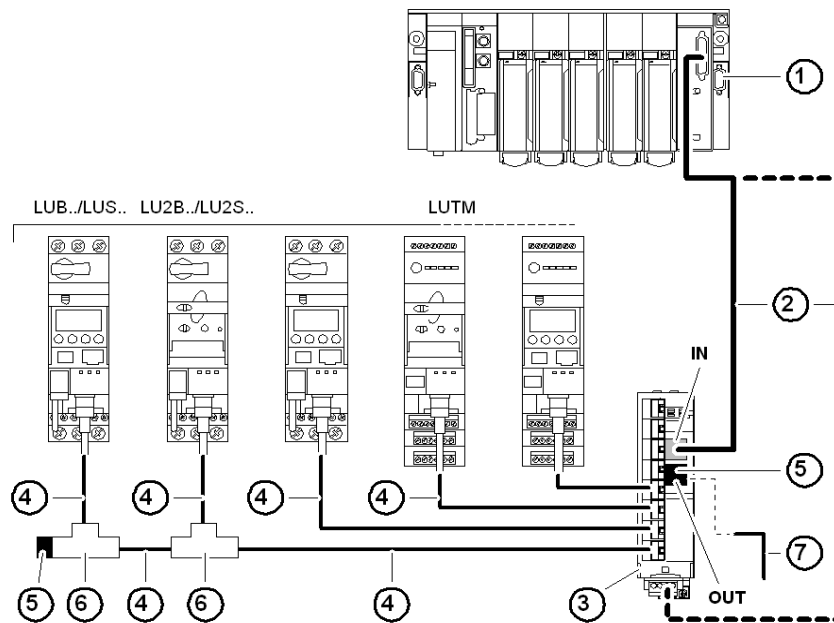

- 1 Master (PLC, PC or communication module)
- 2 Modbus cable depending on the type of master (with polarization integrated on the master side or on another part of the bus)
- 3 Modbus splitter box LU9 GC3
- 4 Modbus drop cables VW3 A8 306 R••
- 5 Line terminators VW3 A8 306 R
- 6 Modbus T-junction boxes VW3A8306TF•• (with cable)
- 7 Modbus cable (to another splitter box) TSX CSA•00 (replaces (5))

NOTE: It is advisable to place a line terminator at each end of the bus to avoid malfunctions on the communication bus. This means that a tee should not have a free connector. It is either connected to a slave or to the master, or there is a line terminator.

NOTE: It is important to connect the bus to the "IN" input (or the screw terminals on the bottom) of the splitter box. Connection to another splitter box is made via the "OUT" output.

Connection Diagrams (PLC <=> Splitter Box)

The two diagrams below describe the connection between:

- Channel 0 of the TSX CSY 21601 module and the LU9 GC3 splitter box using cable TSX SCY CM6030
- PCMCIA card TSX SCP 114 and the LU9 GC3 splitter box using cable TSX SCP CX4030

NOTE: Ensure that the 470 ohm resistors are connected to the 0 V and 5 V polarities correctly.

Connection between TSX SCY 21601 module (channel 0) and splitter box LU9 GC3 using cable TSX SCY CM6030:

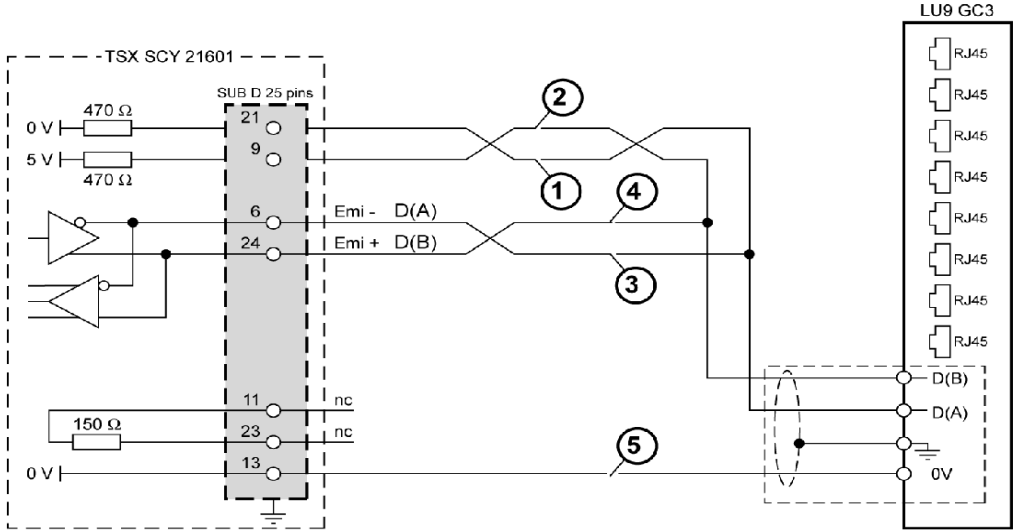

1 Green/White	3 Orange/White	5 Brown/White
2 White/Green	4 White/Orange	

Connection between PCMCIA/TSX SCP 114 card and LU9 GC3 splitter box using cable TSX SCP CX4030:

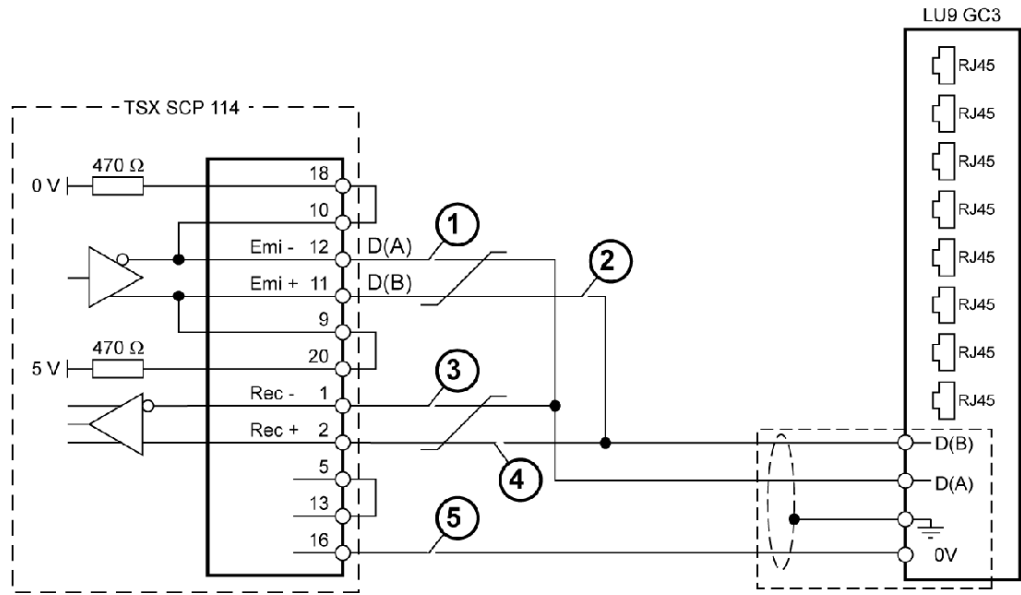

1 Green/White	3 White/Orange	5 Brown/White
2 White/Green	4 Orange/White	

List of connection accessories:

Designation		Catalog number
Modbus splitter box	10 RJ45 connectors and 1 screw terminal	LU9 GC3
Modbus T-junction boxes	With 0.3 m integrated cable	VW3 A8 306 TF03
	With 1 m integrated cable	VW3 A8 306 TF10
Line terminators	For RJ45 connector R = 150 ohms	VW3 A8 306 R

List of connection cables:

Designation	Length (meters)	Connectors	Catalog number
Cables for Modbus bus	3	1 RJ45 connector and 1 stripped end	VW3 A8 306 D30
	0,3		VW3 A8 306 R03
	1	2 RJ45 connectors	VW3 A8 306 R10
	3		VW3 A8 306 R30
RS 485 double shielded twisted pair cables	100	Supplied without connector	TSX CSA 100
	200		TSX CSA 200
	300		TSX CSA 500

List of Modbus connection accessories for RJ45 wiring system:

Type of master	Interface with the master	Description	Catalog number
Twido PLC	Mini-DIN RS 485 adaptor or interface module	3 m cable equipped with a mini-DIN connector and an RJ45 connector	TWD XCA RJ030
	Screw terminal RS 485 adaptor or interface module	3 m cable equipped with an RJ45 connector and stripped at the other end	VW3 A8 306 D30
TSX Micro PLC	Mini-DIN RS 485 terminal port	3 m cable equipped with a mini-DIN connector and an RJ45 connector	TWD XCA RJ030
	PCMCIA card (TSX SCP114)	Stripped cable	TSX SCP CX4030
TSX Premium PLC	TSX SCY 11601 or TSX SCY 21601 module (25-pin SUB-D port)	Cable equipped with a 25-pin SUB-D connector and stripped at the other end (for connection to the screw terminals on the LU9GC3 splitter box)	TSX SCY CM6030
	PCMCIA card (TSX SCP114)	Stripped cable	TSX SCP CX4030
Fipio (LUF1) or Profibus DP (LUF7) or DeviceNet (LUF9) gateway	RS 485 RJ45	Cable, equipped with 2 RJ45 connectors, of the following length:	
		- 0.3 m	VW3 A8 306 R03
		- 1 m	VW3 A8 306 R10
		- 3 m	VW3 A8 306 R30
Serial port PC	PC with 9-pin male SUB-D RS 232 serial port	- RS 232/RS 485 converter	TSX SCA 72
		- 3 m cable equipped with an RJ45 connector and stripped at the other end (for connection to the screw terminals on the LU9GC3 splitter box)	VW3 A8 306 D30

Connection to the Bus via SCA Junction Boxes

The connection diagram for connection to the bus via SCA junction boxes is as follows:

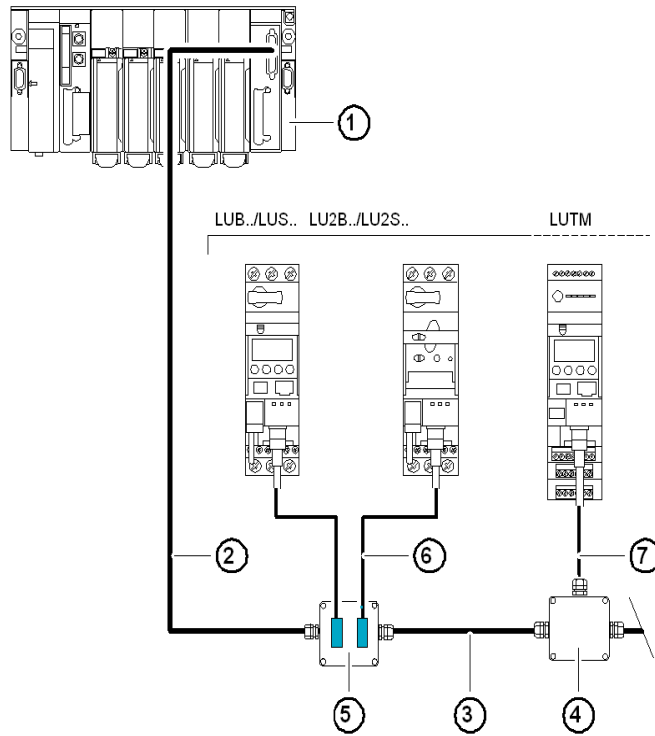

- 1 Master (PLC, PC or communication module).
- 2 Modbus cable depending on the type of master (with polarization integrated on the master side or on another part of the bus).
- 3 Modbus cable TSX CSA•00.
- 4 TSX SCA 50 junction box (without line polarization).
- 5 TSX SCA 62 subscriber port (without line polarization).
- 6 Modbus drop cable VW3 A8 306.
- 7 Modbus drop cable VW3 A8 306 D30.

List of connection accessories:

Designation	Catalog number
Junction box 3 screw terminals and RC line terminator, connected with cable VW3 A8 306 D30	TSX SCA 50
Subscriber port 2 15-pin female SUB-D connectors, 2 screw terminals, and RC line terminator, connected with cable VW3 A8 306 or VW3 A8 306 D30	TSX SCA 62

List of connection cables:

Designation	Length (meters)	Connectors	Catalog number
Cables for Modbus bus	3	1 RJ45 connector and 1 stripped end	VW3 A8 306 D30
	5	1 RJ45 connector and 1 15-pin male SUB-D connector for TSX SCA 62	VW3 A8 306
RS 485 double shielded twisted pair cables	100	Supplied without connector	TSX CSA 100
	200		TSX CSA 200
	300		TSX CSA 300

List of Modbus connection accessories for junction box on screw terminals:

Type of master	Interface with the master	Description	Catalog number
Twido PLC	Screw terminal RS 485 adaptor or interface module	Modbus cable	TSX CSA100 or TSX CSA200 or TSX CSA500
TSX Micro PLC	Mini-DIN RS 485 terminal port	Junction box	TSX P ACC 01
	PCMCIA card (TSX SCP114)	Cable equipped with a special connector and stripped at the other end	TSX SCP CX4030
TSX Premium PLC	TSX SCY 11601 or TSX SCY 21601 module (25-pin SUB-D port)	Cable equipped with a 25-pin SUB-D connector and stripped at the other end	TSX SCY CM6030
	PCMCIA card (TSX SCP114)	Cable equipped with a special connector and stripped at the other end	TSX SCP CX4030
Profibus DP (LA9P307) gateway	RS 485 RJ45	3 m cable equipped with an RJ45 connector and stripped at the other end	VW3 A8 306 D30
Fipio (LUFP1) or Profibus DP (LUFP7) or DeviceNet (LUFP9) gateway	RS 485 RJ45	3 m cable equipped with an RJ45 connector and stripped at the other end	VW3 A8 306 D30
Serial port PC	PC with 9-pin male SUB-D RS 232 serial port	RS 232/RS 485 converter and Modbus cable	TSX SCA 72 and TSX CSA100 or TSX CSA200 or TSX CSA500

RJ45 Connector Pinout

The communication module is connected to the Modbus network with an RJ45 connector in compliance with the following wiring:

Pin no.	Signal
1	Do not connect
2	Do not connect
3	Do not connect
4	D(B) or D1
5	D(A) or D0
6	Do not connect
7	Do not connect
8	0 V.L

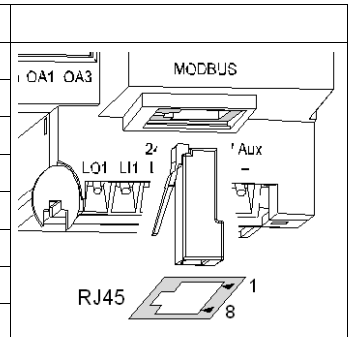

Technical Characteristics

2

Introduction

In addition to information about the module's conditions of use and technical characteristics, this chapter provides instructions on how to replace an LULC031 module with an LULC032-033.

What's in this Chapter?

This chapter contains the following topics:

Topic	Page
Conditions of Use and Technical Characteristics	32
Replacing an LULC031 Module with an LULC032-033 Module	35

Conditions of Use and Technical Characteristics

The characteristics of the LULC032-033 Modbus communication module are as follows:

- Conditions of Use
- Characteristics of the 24V $\overline{\text{---}}$ and 24V Aux power supply circuits
- Characteristics of the outputs (OA1, OA3 and LO1) and logic inputs (LI1 and LI2)

The communication characteristics (module Modbus port) are also described.

Conditions of Use

The conditions of use for the LULC032-033 Modbus communication module are as follows:

Certification	UL, CSA		
Conformity to standards	IEC/EN 255-6, UL 508, CSA C22-2 No. 14		
European Community Directives	CE marking. Satisfies the essential requirements of the low voltage (LV) machinery and electromagnetic compatibility (EMC) directives.		
Temperature of the ambient air around the device	Storage	°C	- 40 ... + 85
	Operation	°C	- 25 ... + 55

24V $\overline{\text{---}}$ Power Supply Circuit

The characteristics of the LULC032-033 Modbus communication module 24 V $\overline{\text{---}}$ power supply circuit are as follows:

Supply voltage	U_{nominal}	V	24 V $\overline{\text{---}}$
	Operating range	V	20 ... 28
Maximum current drawn		A	1
Resistance to microbreaks		ms	2

24 V Aux power-supply circuit

The characteristics of the LULC032-033 Modbus communication module 24 V Aux power supply circuit are as follows:

Supply voltage	U_{nominal}	V	24 V $\overline{\text{---}}$
	Operating range	V	20 ... 28
Maximum current drawn		mA	30
Resistance to microbreaks		ms	3

Logic Outputs OA1, OA3 and LO1

The characteristics of the LULC032-033 Modbus communication module outputs are as follows:

Nominal output values	Voltage	V	24 V ---
	Current	mA	500
Output limit values	Voltage	V	20 ... 28
	Current	mA	500
Coincidence factor of the 3 outputs		%	66
Output response time (register 704) (Time between the request start bit and the change in the output state)		ms	5 (LUCA/B/C/D) 15 (LUCM) 30 (LUCBT/DT) 45 (LUCMT) with stop bit
Protection	Against overvoltage		Yes
	Against inversions		Yes
	Against short-circuits and overloads		Electronic circuit-breaker with automatic reset
Number of operating cycles	In millions of operating cycles		15
Maximum rate	In operating cycles per hour		3600

Logic inputs LI1 and LI2

The characteristics of the LULC032-033 Modbus communication module inputs are as follows:

Nominal input values	Voltage	V	20 ... 28 (positive logic)	
	Current	mA	7	
Input limit values	At state 1	Voltage	V	16
		Current	mA	6
	At state 0	Voltage	V	5
		Current	mA	2
Response time	Change to state 1	ms	10 +/- 30 %	
	Change to state 0	ms	10 +/- 30 %	
Type of input			Resistive	
Protection	gl fuse	A	1	

Communication (Modbus Port)

The technical characteristics of the LULC032-033 Modbus communication module Modbus port are as follows:

Factory configuration			
Physical interface	1	Multidrop RS 485	
Connections		RJ45 on the front panel	
Connection pinout	Schneider standard	D1 (DB) <--> pin 4 D0 (DA) <--> pin 5 OVL <--> pin 8	
Protocol		Modbus RTU	
Physical address	Range	1 to 31 (address 0 not permitted)	1
Logical address	Range	1 to 31 (addresses 32 to 247 not accessible)	
Transmission speed	Bps	1200, 2400, 4800, 9600, 19200 (automatic configuration up to this value)	19200
Parity		Even, Odd (1 stop bit). No parity (1 or 2 stop bits)	Even*
Turnaround time	ms	5 (LUCA/B/C/D) 130 (LUCM) 7 (LUCBT/DT) 140 (LUCMT)	

* All versions (except LULC032 < V1.3: factory-configured with "No parity").

Replacing an LULC031 Module with an LULC032-033 Module

Mounting

The section below presents the LULC031, LULC032 and LULC033 module characteristics in the form of tables.

Mounting modules in different types of base:

	LULC031	LULC032	LULC033
Starter-controller LUB**/LU2B**	Yes	No	Yes
Starter LUS**/LU2S**			
Controller LUTM•OBL	No	Yes	Yes

Combining modules with a control unit:

LULC031	LULC032-033	
LUC***BL only	LUC***BL only with code date > 0406 (Hardware locating device)	LUC•T1BL only (Hardware locating device)

Controlling the I/O

Control of outputs OA1 and OA3 on LULC031 and LULC032-033:

LULC031	LULC032-033	
Starter-controller LUB**/LU2B**	Starter-controller LUB**/LU2B**	Controller LUTM•OBL
Yes	Yes	Yes

Control of output LO1 on LULC031 and LULC032-033:

LULC031	LULC032-033	
Yes	Yes	Yes

Reading inputs LI1 and LI2 on LULC031 and LULC032-033:

LULC031	LULC032-033	
No	Yes	Yes

Control of outputs 13 and 23 on LULC031 and LULC032-033:

LULC031	LULC032-033	
No	Yes	Yes

Electrical Connection

The LULC031 and LULC032-033 module terminals look like this:

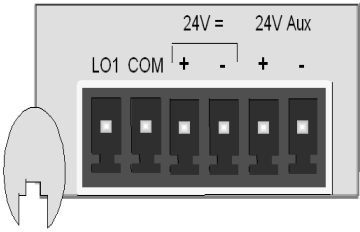
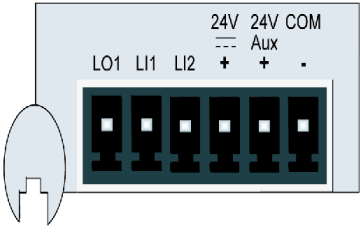
<p>LULC031</p>	
<p>LULC032 LULC033</p>	 <p>2 additional inputs, reduction in the number of commons</p>

Communication Configuration

The address is selected using switches:

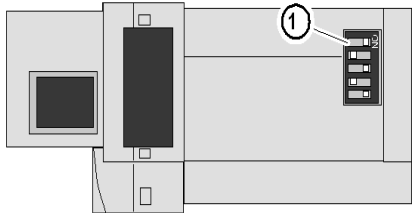
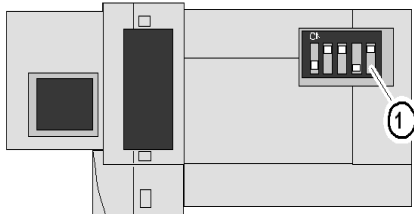
<p>LULC031</p>	 <p>Speed: 19200 baud - Parity: none/1 stop bit</p>
<p>(1) Least significant bit</p>	
<p>LULC032 LULC033</p>	 <p>Speed: 19200 baud - Parity: even*/1 stop bit</p>

* All versions (except LULC032 < V1.3: factory-configured with "No parity").

NOTE: The speed and the parity are calculated automatically by the module. The speed indicated is a maximum value.

Software Configuration

Fallback mode on loss of communication (value of default register):

	Starter-controller LUB••/LU2B••	Controller LUTM••0BL
	Starter LUS••/LU2S••	
LULC031	682 = 0 No detection of loss of communication	-
LULC032	-	681 = 6000 (timeout = 60 seconds) 682 = 2 (fallback mode = forced stop)
LULC033	681 = 6000 (timeout = 60 seconds) 682 = 2 (fallback mode = forced stop)	

Indication of communication losses according to the fallback modes:

LULC031	LULC032-033
Forced stop mode: Fault indicated Other modes: Alarm indicated	Any mode: Alarm indicated Acknowledgment via register 703 bit 3

Firmware version number:

LULC031	LULC032-033
Register 62 = version no. x 100	Register 62 = version no. x 10,000

NOTE: If you are combining an LULC033 module with a multifunction control unit (LUCM) on a power base, you must reinitialize the LUCM on first use.

Software Implementation

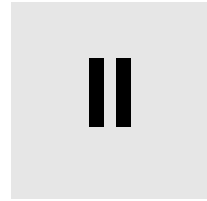

Introduction

Once the LULC032-033 Modbus communication module hardware implementation phase is complete, the software implementation can begin. It focuses on configuration (the various operating modes), and the function parameters to be set (e.g., protection, current measurement, etc.).

What's in this Part?

This part contains the following chapters:

Chapter	Chapter Name	Page
3	Starting up the Module via the Registers	41
4	Fault and Warning Management	55
5	Configuration of Predefined Functions	61

Starting up the Module via the Registers

3

Introduction

This chapter describes how to start up the LULC032-033 communication module by means of the Modbus registers. It provides general information, describes the data-exchange format, the product's factory configuration and how it can be customized, and also the Modbus read and write requests.

What's in this Chapter?

This chapter contains the following topics:

Topic	Page
General Information on Start-up via the Registers	42
Data-Exchange Format	43
Factory Configuration	45
Customizing Your Configuration	46
Modbus Requests and Programming Examples	52
Use of the Main Registers for Simplified Management	53

General Information on Start-up via the Registers

All the LULC032-033 communication module settings are implemented - or simply displayed - via the Modbus registers.

Access to Parameters

The module I/O parameters are set by one of the following three methods:

- The Modbus RJ45 port, via the application PLC
- The LUCM multifunction control unit's terminal port
- Locally, via the LUCM multifunction control unit's keypad

Data-Exchange Format

Modbus Format

Communication is based on the slave Modbus RTU protocol.

The data format is as follows:

1 start bit	8 data bits	1 parity bit	1 stop bit
-------------	-------------	--------------	------------

NOTE: The detailed format of these requests is explained on the www.Modbus.org site.

Initialization

Initialization consists of two phases:

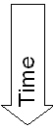
 Time	<p>When the auxiliary 24 V is powered up, the LULC032-033 Modbus communication module is initialized:</p> <ul style="list-style-type: none"> • The addressing is taken into account. • The type of control unit is taken into account.
	<p>At the end of the initialization phase, the LULC032-033 Modbus communication module automatically identifies the configuration parameters (speed and parity) of the RS 485 link as soon as traffic is detected on the network.</p> <p>After analysis of up to 20 frames at a speed of 19,200 baud, initialization continues (at 1200 baud, the number of frames is higher):</p> <ul style="list-style-type: none"> • The default or configured speed is taken into account. • The Master parity is taken into account.

Read-Write Zones

The memory zone from 0 to 19,999 can be accessed by the client.

- Reading the zone of a 'Reserved' register (or non-set) causes a correct response (value 0).
- Writing to the zone of a 'Reserved' register causes a correct response (value 0). The write operation is not taken into account and the contents remain equal to 0.
- Writing to the zone of a 'Read only' register causes a response with an exception code (code 03).

The memory zone 2000 is private and therefore reading/writing is not authorized. All accesses will be signaled by an exception code (code 02).

Exception Code

The presence of an exception code is indicated by the report from the PLC (refer to the Modbus master module documentation).

The Modbus exception codes supported are as follows:

Value of the exception code		Name	Comment
Hexadecimal	Decimal		
0x01	1	Illegal function	Unknown request code
0x02	2	Illegal data address	<ul style="list-style-type: none"> • Register address invalid • Access to the private memory zone (address \geq 20000) • Writing to a "read-only" register <p>The memory zone is prohibited in both read and write modes</p>
0x03	3	Illegal data value	<ul style="list-style-type: none"> • Invalid value <p>The write command is interrupted</p>

Speed and Parity

The recognized values are as follows:

	Possible values	Factory value
Speed	1200, 2400, 4800, 9600 and 19,200 baud.	19,200 baud
Parity	Even, odd, no parity (parity bit deleted).	Even*

* All versions (except LULC032 < V1.3: factory-configured with "No parity").

TSX Micro or Premium Platform

Applications for Micro and Premium PLCs are designed and implemented using PL7 software.

READ_VAR or WRITE_VAR requests (*see Modbus Requests and Programming Examples*) are used to read or write respectively the value of one or more consecutive objects of the same type (bit, word), in PL7 language.

NOTE: For more details concerning Modbus communication programming within a TSX platform, refer to the PL7 online help, Communication Volume 2/Modbus communication.

Factory Configuration

The communication module parameters are set in order to determine:

- The operating mode
- The reset mode for thermal overload faults
- The correspondence between the communication module outputs and the LUTM controller inputs

The parameter registers (Modbus protocol) are accessible in read/write mode. The factory-set values are as follows:

Topic	Register	Factor y value	Meaning
Reset mode for thermal overload fault	602.0	1	"Manual" mode
Enable communication between LUCM/MT and LULC032	602.4	1	Communication active
Fallback mode for control outputs on loss of communication	682	2	Forced stop Power base: OA1 and OA3 at 0 Controller base: 13 and 23 at 0
Local operating mode or via the bus with the LUTM and LULC032	683	0	Mode for controlling the LUTM controller outputs " remotely via the bus "
Inversion of the LULC032 outputs	684	0	The state of the outputs is the image of the control bits
On power base, assignment of: - Output LO1 - Output OA1 - Output OA3 On controller base, assignment of: - Output 13 - Output 23	685 LSB 686 LSB 686 MSB 687 LSB 687 MSB	2 12 13 12 13	LO1 is the state of control bit 700.0 OA1 is the state of control bit 704.0 OA3 is the state of control bit 704.1 13 is the state of control bit 704.0 23 is the state of control bit 704.1
Recovery mode after stopping	688	0	The outputs revert to the state they were in before the power cut.
Control unit ID	690	0	The control unit is identified automatically

NOTE: For more information, refer to the "TeSys U Communication Variables" User's Manual.

Customizing Your Configuration

You can use the factory settings (*see Factory Configuration*) or customize your configuration.

The following parameters can be set:

- Control unit configuration
- Control unit ID
- Timeout duration
- Fallback mode
- Control mode with a LUTM controller.
- Inversion of the output states
- Assignment of outputs LO1, OA1, OA3, 13 and 23
- Recovery after stopping
- Control unit forcing

WARNING

UNEXPECTED OPERATION

A configuration can be loaded or edited via both Modbus ports (via the communication module or via the control unit LUCM). One configuration can then overwrite another, as the system does not prevent such an action. The result is not certain.

Failure to follow these instructions can result in death, serious injury, or equipment damage.

Control unit configuration (Reg 602)

Register **602** (accessible in read/write mode) is used to configure the control unit (reset mode 602.0-2, and communication 602.4).

Reg•	Value	Comment
602.0	1	Resetting is manual (by default). Bits 1 and 2 are at 0.
	0	You have activated either bit 1 (remote reset) or bit 2 (automatic reset)
602.4	1	Communication with the LUCM/MT multifunction control unit has been activated.
	0	When forced to 0, this bit inhibits communication between the LUCM/MT multifunction control unit and the LULC032-033 Modbus communication module.

Control unit configuration (Reg 680)

The control unit is identified each time the communication module is powered up.

However, the multifunction control unit memorizes the reference of the communication module assembled with it.

To use a multifunction control unit on its own, once it has been used with a communication module, identification register 680 is reinitialized locally via the keypad in the menu (Id = 0) or via the remote LUCM Modbus terminal port (value 0 written to register **680**).

Timeout Duration (Reg 681)

Register **681** (accessible in read/write mode) is used to set or read the value of the timeout on loss of communication with the PLC. Following loss of communication, the timeout corresponds to the time before switching to fallback mode. Loss of communication results in a warning, which is signaled by register 460 = 109.

Reg•	Value	Range	Unit	Factor y value	Comment
681	-	0 - 65535	10 ms	6000	Value of timeout The value 0 represents a time of zero.

Fallback mode (Reg 682)

Register **682** (accessible in read/write mode) is used to configure the fallback mode in the event of loss of communication with the PLC.

Register 682 Value	Fallback Mode
0	Ignored
1	Freeze outputs
2	Stop
3	Signal comm loss warning
4	Force run forward
5	Force run reverse

 WARNING**AUTOMATIC RESTART OF THE MOTOR**

When communication stops, outputs OA1-OA3 take the status corresponding to the selected fallback mode (register 682), but command bits 704.0 and 704.1 are not modified.

During the loss of communication warning (register 703 or push button on the controller), the motor will restart automatically if command bits 704.0 or 704.1 have not been reset to zero first by the PLC application.

Failure to follow these instructions can result in death, serious injury, or equipment damage.

Description of the different fallback modes:

Fallback Mode	Loss of Communication	Communication Recover	Loss of Communication Acknowledgement
Ignored (reg 682 = 0)	No detection of the loss of communication	No detection of the loss of communication	No acknowledgement of the loss of communication
	OA1 and OA3 keep their status	OA1 and OA3 keep their status	
Freeze outputs (reg 682 = 1)	OA1 and OA3 keep their status	OA1 and OA3 keep their status	On rising edge by bit 703.3 (do not leave set to 1)
	ERR LED blinking on the front face	ERR LED blinking on the front face	Once the acknowledgement is done, the last command stored in register 704 is enabled
		Every new On/Off command is stored but with no impact on OA1 and OA3	ERR LED switches off
Stop (reg 682 = 2)	OA1 and OA3 are forced to 0	OA1 and OA3 are forced to 0	On rising edge by bit 703.3 (do not leave set to 1)
	ERR LED blinking on the front face	ERR LED blinking on the front face	Once the acknowledgement is done, the last command stored in register 704 is enabled
		Every new On/Off command is stored but with no impact on OA1 and OA3	ERR LED switches off
Signal comm loss warning (reg 682 = 3)	OA1 and OA3 keep their status	OA1 and OA3 keep their status	On rising edge by bit 703.3 (do not leave set to 1)
	ERR LED blinking on the front face	ERR LED blinking on the front face	ERR LED switches off
		Every new On/Off command is considered and has an impact on OA1 and OA3	
Force run forward (reg 682 = 4)	OA1 is forced to 1 OA3 is forced to 0	OA1 is forced to 1 OA3 is forced to 0	On rising edge by bit 703.3 (do not leave set to 1)
	ERR LED blinking on the front face	ERR LED blinking on the front face	Once the acknowledgement is done, the last command stored in register 704 is enabled
		Every new On/Off command is stored but with no impact on OA1 and OA3	ERR LED switches off
Force run reverse (reg 682 = 5)	OA1 is forced to 0 OA3 is forced to 1	OA1 is forced to 0 OA3 is forced to 1	On rising edge by bit 703.3 (do not leave set to 1)
	ERR LED blinking on the front face	ERR LED blinking on the front face	Once the acknowledgement is done, the last command stored in register 704 is enabled
		Every new On/Off command is stored but with no impact on OA1 and OA3	ERR LED switches off

NOTE: The red 'ERR' LED flashes to indicate a loss of communication (fault on timeout).

Control Mode (Local/Bus) with an LUTM Controller (Reg 683)

Control of outputs 13 and 23 on the LUTM controller depends on the operating mode selected in register 683.

Value	Operation		Comment
0	'Remote via the bus' mode	Outputs 13 and 23 are only controlled by the bus. <i>The state of inputs I.1 and I.2 does not affect outputs 13 and 23.</i>	
1	'Local' mode	Outputs 13 and 23 are only controlled by inputs I.1 and I.2. <i>Commands via the bus are not taken into account.</i>	
2	'Mixed' mode (input I.10 has priority)	'Local' mode if I.10 = 1	Outputs 13 and 23 are only controlled by inputs I.1 and I.2. <i>Commands via the bus are not taken into account.</i>
		'Remote via the bus' mode if I.10 = 0	Outputs 13 and 23 are only controlled via the bus, from the PLC. <i>The state of inputs I.1 and I.2 does not affect outputs 13 and 23.</i>

NOTE: Commands transmitted during communication are passed directly to the output relays, without wiring between the communication module outputs and inputs I.1 and I.2.

Inversion of output states (Reg 684)

Depending on requirements (signaling, run, stop, etc.), it is possible to assign NO or NC behavior to outputs OA1, OA3 and LO1, by configuring register 684.

To do this, define the output concerned ==> register 684.

Power base	Bit
Invert output OA1	_.0 = 1
Invert output OA3	_.1 = 1
Invert output LO1	_.2 = 1

Modifying Output Assignments

The tables below show how the assignments of outputs LO1, OA1, OA3, 13, and 23 can be modified. To modify the assignments (factory values), write a different value (0 to 45), referring to the 'TeSys U Communication Variables' User's Manual.

WARNING

UNEXPECTED OPERATION

Before modifying an output's assignment by means of parameterization, you must note the following information. Otherwise, you run the risk of unexpected operation.

Failure to follow these instructions can result in death, serious injury, or equipment damage.

Register 704 is used for controlling the motor-starter. The following are associated with this register: functions for monitoring loss of communication, fallback mode (register 682), reflex functions or recovery mode after stopping (register 688). Only the outputs activated by bits 704.0 and 704.1 benefit from these functions.

In addition, command bits 704.0 and 704.1 are independent and can be activated simultaneously.

Using register 700 to activate outputs is comparable with unconditional forcing.

Setting the parameters of output LO1 (Reg 685 LSB)

Assignment/control (factory value) of output LO1 on the LULC032 Modbus communication module is as follows:

Reg•	Bit	Value	Factory value	Comment
685	0 to 7	0 to 45	2	Output LO1 = state of register 700.0

Setting the Parameters of Output OA1 (Reg 686 LSB)

Assignment/control (factory value) of output OA1 on the LULC032-033 Modbus communication module is as follows:

Reg•	Bit	Value	Factory value	Comment
686	0 to 7	0 to 45	12	Output OA1 = state of register 704.0

Setting the Parameters of Output OA3 (Reg 686 MSB)

Assignment/control (factory value) of output OA3 on the LULC032-033 Modbus communication module is as follows:

Reg•	Bit	Value	Factory value	Comment
686	8 to 15	0 to 45	13	Output OA3 = state of register 704.1

Setting the Parameters of Output 13 (Reg 687 LSB)

Assignment/control (factory value) of output 13 on the LUTM controller is as follows:

Reg•	Bit	Value	Factory value	Comment
687	0 to 7	0 to 45	12	Output 13 = state of register 704.0

Setting the Parameters of Output 23 (Reg 687 MSB)

Assignment/control (factory value) of output 23 on the LUTM controller is as follows:

Reg•	Bit	Value	Factory value	Comment
687	8 to 15	0 to 45	13	Output 23 = state of register 704.1

Recovery mode (Reg 688)

If you use register 704 to control outputs OA1-OA3, writing the value 1 to register 688 allows you to lock the motor and prevent it restarting following the occurrence of certain events:

- Loss followed by restoration of 24V DC (outputs OA1-OA3)
- Change in position of rotary knob on power base followed by return to Ready position.

When one of these events occurs, command bits 704.0 and 704.1 (outputs OA1-OA3) are forced to 0 automatically. As long as one of these events remains pending, if values are written to register 704, the module will return exception code 02. Once these conditions have disappeared, control of the motor can be restored by sending a new run command.

⚠ WARNING
AUTOMATIC RESTART OF THE MOTOR
In the case of cyclic writing to register 704 (e.g., an LUFF• gateway in its predefined configuration), this monitoring function must be used with caution. The application program must take this state into account and request that bits 704.0 or 704.1 are written to 0. Otherwise, when this event disappears, the motor will restart automatically.
Failure to follow these instructions can result in death, serious injury, or equipment damage.

Forcing control unit (Reg 690)

The control unit is identified automatically, but identification can be forced.

Value	Comment
0	Default value. The system automatically identifies the type of control unit connected (standard, advanced, multifunction).
1	If the value is set to 1, this deactivates automatic identification and forces identification of a standard or advanced control unit.
2	If the value is set to 2, this deactivates automatic identification and forces identification of a multifunction control unit.

NOTE: (Read/Write) registers 681 to 690 can also be accessed via the LUCM keypad.

Modbus Requests and Programming Examples

Modbus Requests

The recognized Modbus requests are as follows:

Code value		Name	Comment
Hexadecimal	Decimal		
0x03	3	Read multiple registers	Read mode
0x06	6	Write single register	Write mode
0x10	16	Write multiple registers	
0x2B	43	Read register identification	Read mode for identifying the LULC032-033 Modbus communication module

The maximum number of registers per request is limited to 100.

NOTE: The "Broadcast" function is supported. To use it, a write operation (code 6 or 16) to address 00 is necessary.

⚠ WARNING

UNEXPECTED OPERATION

Use of this device on a Modbus network that uses the broadcast function should be considered with caution.

This device has a large number of registers that must not be modified during normal operation. Unintended writing of these registers by the broadcast function may cause unexpected and unwanted product operation.

For more information, refer to the "Internal Communication Variables" User's Manual.

Failure to follow these instructions can result in death, serious injury, or equipment damage.

Example of a Read Operation

The example below describes a READ_VAR request, within a TSX Micro or Premium platform, in order to read the motor-starter states at address 4 (slave no. 4) contained in internal word MW0:

```
IF %M0 AND NOT %MW100:X0 THEN READ_VAR (ADR#3.0.4, '%MW', 455, 1, %MW0:1, %MW100:4) :RESET %M0;
EN_IF;
```

- 1 Address of the module with which you wish to communicate: 3 (module address), 0 (channel), 4 (module address on the bus)
- 2 Type of PL7 objects to be read: MW (internal word)
- 3 Address of the first register to be read: 455
- 4 Number of consecutive registers to be read: 1
- 5 Word table containing the value of the objects read: MW0:1
- 6 Read report: MW100:4

Example of a Write Operation

The example below describes a WRITE_VAR request, within a TSX Micro or Premium platform, in order to control a motor-starter by sending the content of internal word MW 502:

```
IF %M0 AND NOT %MW200:X0 THEN WRITE_VAR (ADR#3.0.4, '%MW', 704, 1, %MW502:1, %MW200:4) :RESET %M10;
EN_IF;
```

- 1 Address of the module with which you wish to communicate: 3 (module address), 0 (channel), 4 (module address on the bus)
- 2 Type of PL7 objects to be written: MW (internal word)
- 3 Address of the first register to be written: 704
- 4 Number of consecutive registers to be written: 1
- 5 Word table containing the value of the objects to be sent: MW502:1
- 6 Write report: MW200:4

Use of the Main Registers for Simplified Management

Before implementing a motor-starter, it is useful to know which of the main registers are invoked, and in what order.

Diagram of Register Usage

The diagram below provides basic implementation information, using the following registers: configuration, control and monitoring (system state, measurements, faults and warnings, acknowledgment). Starting with the factory configuration (predefined), you will easily be able to follow or anticipate how your system behaves.

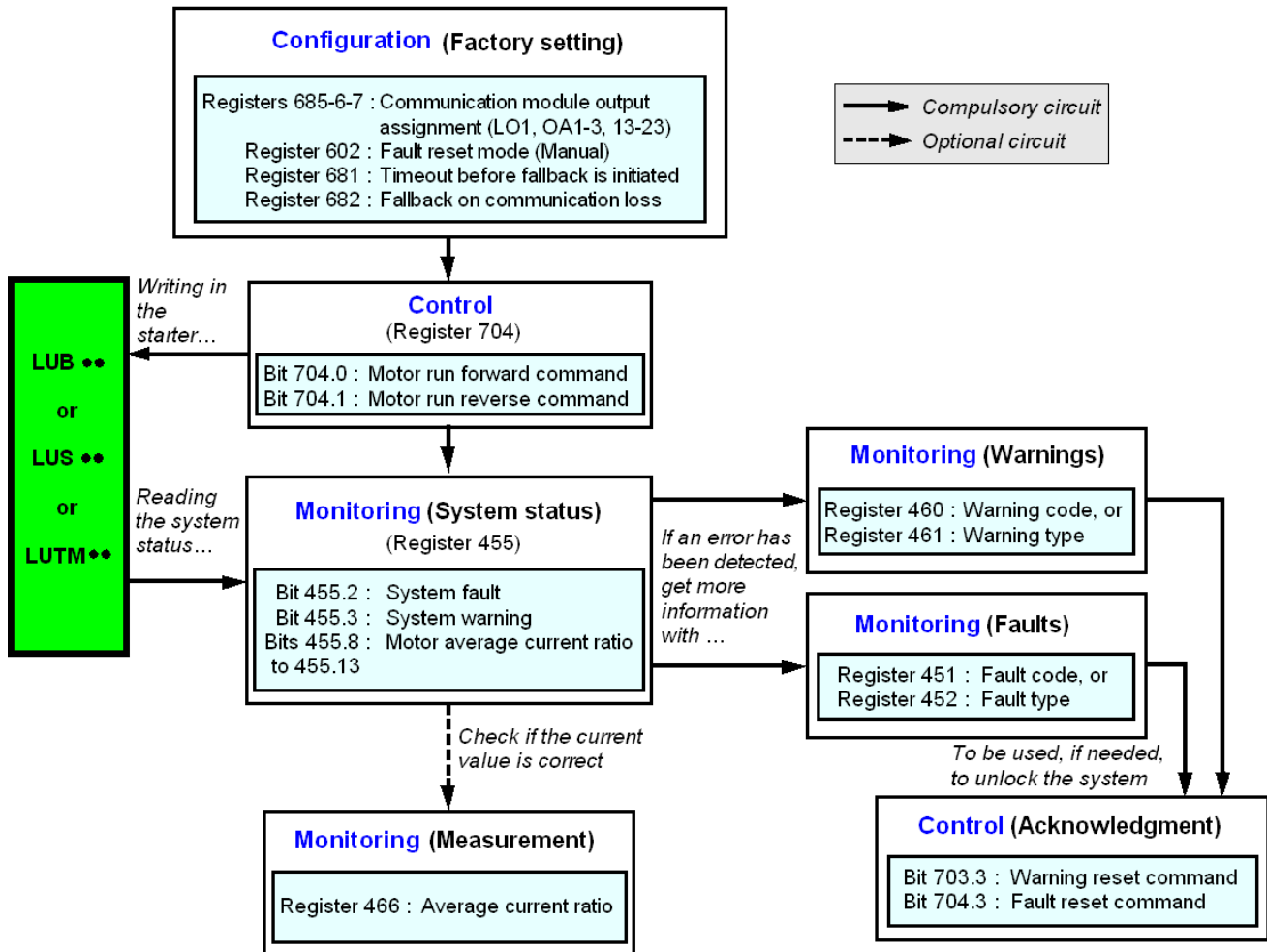

Fault and Warning Management

4

This chapter shows how to manage the various types of fault and warning that may occur.

What's in this Chapter?

This chapter contains the following topics:

Topic	Page
Displaying Faults	56
Application Faults	57
Warnings - Loss of Communication	58
Internal Faults	59

Displaying Faults

The presence of a fault is signaled by various indicators:

- State of the LEDs on the LULC032-033 Modbus communication module

With a power base:

- State of the power base rotary knob (0 or "trip")
- State of the output relays

With a controller base:

- State of the LEDs on the controller base
- State of the output relays

With a standard or advanced control unit:

- Internal signals sent to the LULC032-033 Modbus communication module

With a multifunction control unit:



- Warning
- Message(s) displayed on-screen
- Internal dialog with the LULC032-033 Modbus communication module
- Presence of an exception code (report from the PLC). See *Exception Code, page 43*.

NOTE: The warning and the fault are taken into account in the relevant registers. For more information, refer to the "TeSys U Communication Variables" User's Manual: fault monitoring registers (450 to 452) and warning monitoring registers (460 to 461).

Application Faults

Acknowledgement of Application Faults

The possible application faults are listed below. Their reset (or acknowledgment) method can be: manual/automatic/remote.

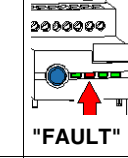
Application faults	Registers		LULC032 LULC033	LUCM•	LUTM	Fault acknowledgment
	451 Fault number	452 Fault bit	 "ERR"	 (line 2)	 "FAULT"	
Short-circuit fault	1	_.0 = 1	Off	DC	-	Manual reset
Overcurrent fault	2	_.1 = 1		I>>	-	
Thermal overload fault	4	_.3 = 1		Overload	-	According to the reset mode configured in register 602
Application fault in the LUCM• multifunction control unit	3 and 5 to 12	Refer to the User's Manual for the LUCM••BL or LUCMT1BL multifunction control unit				

Overload Fault with LU•B•/LU•S• Power Base

Following a thermal overload fault, either the rotary knob or the blue pushbutton on the front panel can be used, irrespective of which reset mode has been configured.

Configuration register	Reset (acknowledgment)	Method
602.0 = 1	"Direct manual "	With the rotary knob on LU•B• With the blue pushbutton on LU•S•
	"Remote manual "	With the LU9 AP•• kit on LU•B• With the LU9 •• kit on LU•S•
602.1 = 1	" Remote "	Acknowledgment by bit 704.3 This bit is active on rising edge and must be reset to 0 by programming.
602.2 = 1	" Automatic "	Managed by the control unit

Overload Fault with LUTM Controller Base

Following a thermal overload fault, either the blue pushbutton on the front panel or input I.5 can be used, irrespective of which reset mode has been configured.

Configuration register	Reset (acknowledgment)	Method
602.0 = 1	"Local manual "	With the blue pushbutton on the front panel
	"Remote manual "	With the reset button on the front of the rack or control panel (via Input I.5)
602.1 = 1	" Remote "	Acknowledgment by bit 704.3 This bit is active on rising edge and must be reset to 0 by programming.
602.2 = 1	" Automatic "	Managed by the control unit



NOTE: The reset mode must be configured.

Warnings - Loss of Communication

Warning Acknowledgment

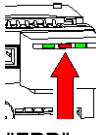
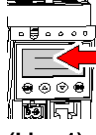
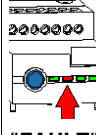
List of possible warnings.

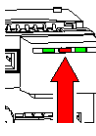
Warnings	Registers		LULC032 LULC033	LUCM•	LUTM	Acknowledgment of a warning
	460 Warning number	461 Warning bit	 "ERR"	 (Line 1)	 "FAULT"	
Thermal overload warning	4	_.3 = 1	-	Overload warning	-	Automatic when the overload is less than 85%
Loss of communication with the master warning	109	_.15 = 1	Flashing	Comm Loss	-	Acknowledgement by bit 703.3 This bit is active on rising edge and must be reset to 0 by programming.
LUCM• multifunction control unit warning	2 and 4 to 13	Refer to the User's Manual for the LUCM•BL or LUCMT1BL multifunction control unit.				

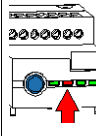
Warnings	Registers		LULC032 LULC033	LUCM•	LUTM	Acknowledgment of a warning
	460 Warning number	461 Warning bit	 "ERR"	 (Line 2)	 "FAULT"	
LUTM external warning indicated by I.6 changing to 0	201	_.15 = 1	-	Warn-M201	Refer to the LUTM Controller User's Manual.	Automatic with I.6 returning to 1



Recovery After Loss of Communication

After acknowledgment by setting bit 703.3 to 1, recovery occurs according to the states of control bits 704.0 and 704.1.

Internal Faults

Acknowledgment of Internal Faults

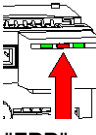
List of possible internal faults.

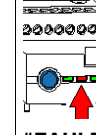
Internal faults	Registers		LULC032 LULC033	LUCM•	LUTM	Fault acknowledgment
	451 Fault number	452 Fault bit	 "ERR"	 (Line 2)	 "FAULT"	
Fault on the LULC032-033 Modbus communication module	14	-	Off	M14	-	Power down and then power up the LULC032-033 and the LUCM•
LULC032-033 Modbus communication module not installed or not supplied with power, or loss of communication with the module	15	-		M15	-	
Internal fault in the LUC•• control unit	54	_.11 = 1		M54	-	
Fault in the LUCM• multifunction control unit	51 to 53, 55 to 63	Refer to the User's Manual for the LUCM••BL or LUCMT1BL multifunction control unit.				
Write-to-EEPROM fault	100	_.13 = 1	On	M100	-	Power down and then power up the LULC032-033
Communication fault with the LUCM• multifunction control unit	101	_.12 = 1	On	M101	Flashing	Power down and then power up the LULC032-033
Checksum fault in EEPROM	102	_.13 = 1	On	M102		Rising edge on 704.3=1
EEPROM configuration fault	104	_.13 = 1	On	M104		Rising edge on 704.3=1
Communication fault with the LUTM controller base	105	_.13 = 1	On	M105		Power down and then power up the LULC032-033
Communication fault with the LULC032-033 module	205	_.13 = 1	On	-	Refer to the LUTM Controller User's Manual.	Power down and then power up the LUTM
No control unit	206					Power down and then power up the LUTM

Configuration of Predefined Functions

5

This chapter describes the predefined functions.

What's in this Chapter?

This chapter contains the following topics:

Topic	Page
Description of Reflex Stop Functions	62
Use of Reflex1 and Reflex2	64

Description of Reflex Stop Functions

The reflex stop ensures accurate repeated position control, unhindered by the bus and PLC scan times.

There are two types of reflex stop function:

- Reflex1: "Reflex stop 1" function
- Reflex2: "Reflex stop 2" function

Description of Reflex1

Sensor no. 1 (logic input LI1) directly controls motor stopping.

After a new run command (stop command then run command), the motor restarts even if something is still detected (LI1=1).

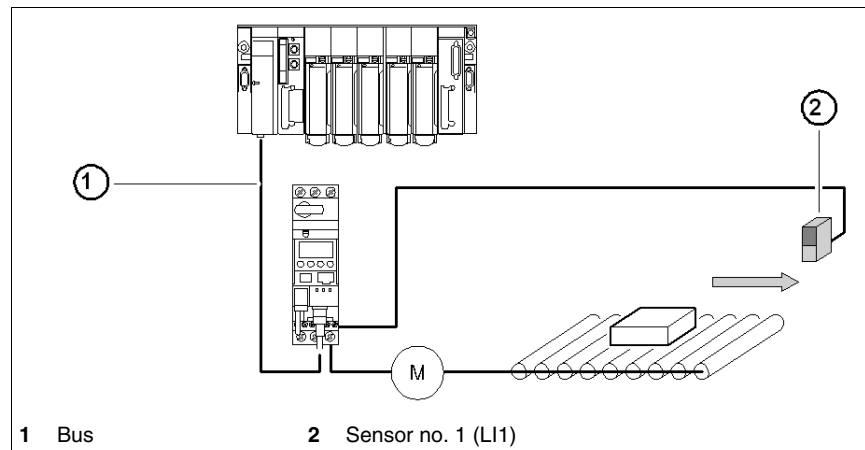

NOTE: In the case of a reversing starter, the reflex stop works in both directions.

Data sequence

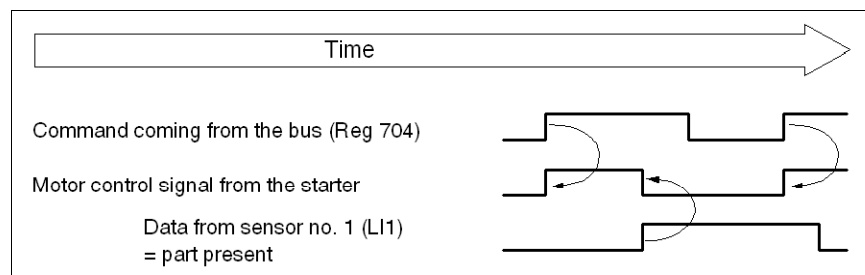

Description of Reflex2

Sensor no. 1 (logic input LI1) controls motor stopping in forward mode.

Sensor no. 2 (logic input LI2) controls motor stopping in reverse mode.

After a new run command (stop command then run command), the motor restarts even if something is still detected (LI1 or LI2 = 1).

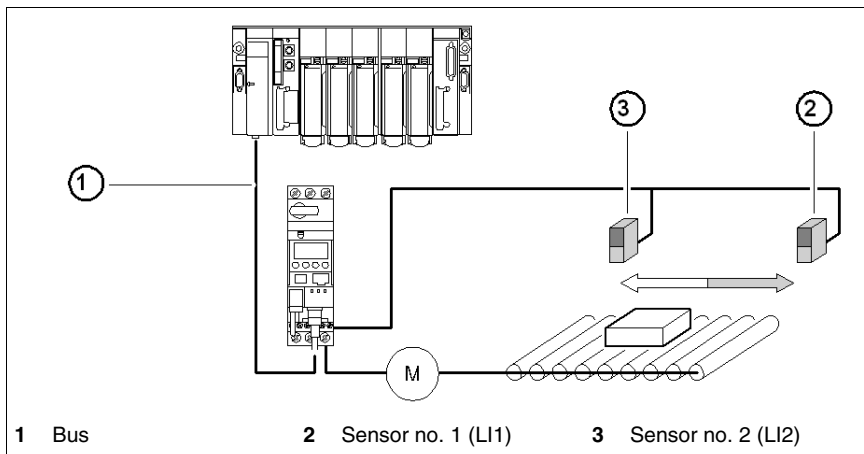

NOTE: Sensor no. 2 (LI2) does not affect forward mode and sensor no. 1 (LI1) does not affect reverse mode.

Use of Reflex1 and Reflex2

To use a "reflex stop" function, it must be selected in the register of the output to be monitored.

Reflex function	Direction of motor rotation	Value of Reg•	LUB••/S•• - LU2B••/2S•• base		LUTM•• base
			Output LO1	Outputs OA1 OA3	Outputs 13 23
Reflex1	Reflex1.Fw = forward	8	Reg685 (LSB)	Reg686 (LSB) (MSB)	Reg687 (LSB) (MSB)
	Reflex1.Rev = reverse	9			
Reflex2	Reflex2.Fw = forward	10			
	Reflex2.Rev = reverse	11			

NOTE: Before using the "reflex stop" functions, outputs OA1/OA3 must first be assigned to the forward/reverse directions. This selection is made in register **686**. By default, OA1 is assigned to forward and OA3 to reverse.

Reflex1.Fw

This function is active on a rising edge and not on the level.

.Fw	LI1 = 1 stops the motor, irrespective of the chosen direction of operation. After a new run command (stop command followed by a run command), even if logic input LI1 = 1, the motor restarts in the chosen direction.
-----	---

NOTE: Logic input LI2 is not used.

Reflex1.Rev

This function is active on a rising edge and not on the level.

.Rev	LI1 = 1 stops the motor, irrespective of the chosen direction of operation. After a new run command (stop command followed by a run command), even if logic input LI1 = 1, the motor restarts in the chosen direction.
------	---

NOTE: Logic input LI2 is not used.

Reflex2.Fw

This function is active on a rising edge and not on the level.

.Fw	Logic input LI1 = 1 stops the motor in forward mode. Logic input LI2 = 1 stops the motor in reverse mode. After a new run command (stop command followed by a run command), even if logic input LI2 = 1, the motor restarts.
-----	--

NOTE: Logic input LI2 does not affect forward mode and logic input LI1 does not affect reverse mode.

Reflex2.Rev

This function is active on a rising edge and not on the level.

.Rev	Logic input LI2 = 1 stops the motor in reverse mode. Logic input LI1 = 1 stops the motor in forward mode. After a new run command (stop command followed by a run command), even if logic input LI2 = 1, the motor restarts.
------	--

NOTE: Logic input LI2 does not affect forward mode and logic input LI1 does not affect reverse mode.

Index

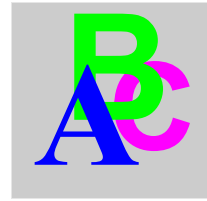

A

- Acknowledgement
 - Application Fault, 57
- Acknowledgment
 - Internal Fault, 59
 - Warning, 58
- Addressing, 16, 36
- Application Faults, 57

C

- Cables, 26, 28
- Conductor, 22
- Connection, 15
 - SCA Junction Box, 28
 - Splitter Box, 24
 - Tee (Direct), 23
- Connectors, 15
- Control Mode, 49
- Control unit
 - configuration, 46
 - Forcing, 51
 - Identification, 46
- Control unit (LUC...), 14
- Controller Base, 17, 19
- Cords, 26, 28

D

- Data Exchange
 - Exception Code, 43
 - Format, 43
 - Initialization, 43
- Diagram of the Module, 15

E

- Electrical Connection, 18
- Exception Code, 43

F

- Fallback mode, 47
- Faults, 56
- Forcing
 - Control unit, 51

I

- Identification
 - Control unit, 46
- Indicator Lights, 15, 16

- Input, 33
- Input (on Diagram), 15
- Internal Faults, 59
- Inversion
 - Output State, 49

J

- Junction Box, 29

L

- LEDs, 15, 16
- Link
 - Prewired, 21
 - Wire-to-Wire, 21
- Loss of communication, 47
- Loss of Communication, 58
- LUCA, 14
- LUCB/C/D, 14
- LUCM, 14, 19
- LULC031, 15, 35

M

- Modbus Format, 43
- Modbus Port, 34
- Modbus Request, 52
 - Read, 52
 - Write, 52
- Module, 25
- Module Functions, 13

O

- Order of Mounting, 17
- Output, 33
 - Setting, 49
- Output (on Diagram), 15
- Output State
 - Inversion, 49

P

- Parameters, 42
- Parity, 44
- PCMCIA Card, 25
- Pinout (RJ45), 29
- PL7, 44
- Power Base, 17, 19
- Power Supply, 18, 20, 21, 32
- Power-up, 19

R

Read-Write Zones, 43
Receiving the Product, 13
Recovery after stopping, 50
Reflex Stop, 62
Reflex1, 62, 64
Reflex2, 63, 64
Registers, 42, 45
RJ45, 26, 26, 28, 29
RJ45 Wiring, 26
RS 485 Bus, 23

S

Setting
 output, 49
Speed, 44
Switches, 16, 36

T

Timeout
 Duration, 46

W

Warning, 58