

THIS COPY IS PROVIDED ON A RESTRICTED BASIS AND IS NOT TO BE USED IN ANY WAY DETRIMENTAL TO THE INTERESTS OF PANDUIT CORP.

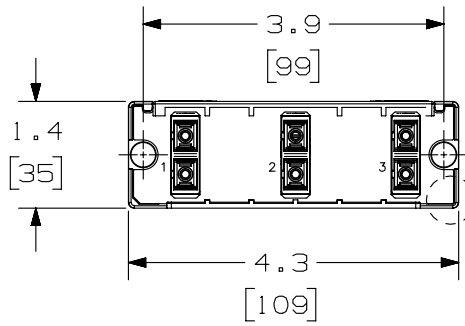
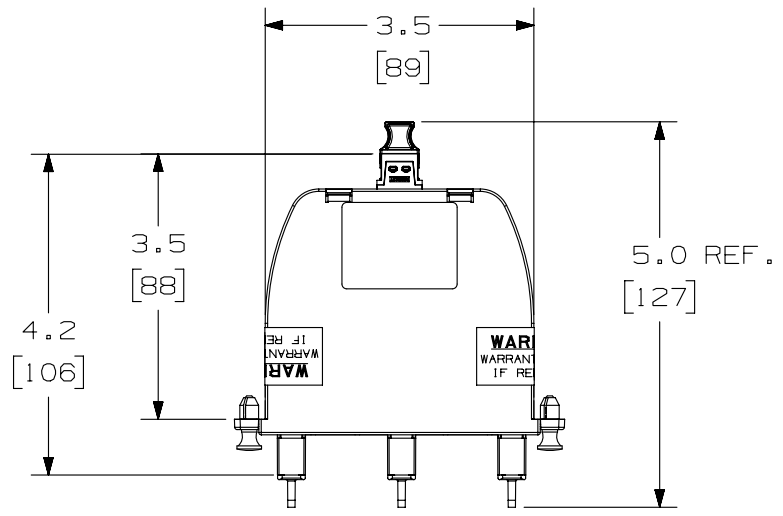

FRONT VIEW
SHOWN W/O DUSTCAPS

SEE SHEETS 2 AND 3 FOR ARTWORK DETAILS

NOTES:

1. SEE CURRENT CATALOG FOR PART NUMBER SUFFIXES TO INDICATE COLOR AND/OR PACKAGE QUANTITIES.
2. SEE CATALOG FOR COMPLETE LIST OF PARTS APPLICABLE FOR USE WITH THIS PRODUCT.
3. PART NUMBERS:
 - A. SEE SHEET 2 FOR METHOD A.
 - B. SEE SHEET 3 FOR MODIFIED METHOD A, PAIR FLIPPED.
4. METHOD A CASSETTES COMPLY WITH ANSI/TIA-568-C.0. SEE ANSI/TIA-568-C.0 FOR POLARITY DETAILS AND EXAMPLE OF A BASIC LINK.
5. MATERIALS:
 - A. BOX AND LID: PLASTIC
 - B. ADAPTER: COMPOSITE PLASTIC
6. CASSETTE WEIGHT: 3.95oz [112g]
7. DIMENSIONS IN BRACKETS ARE METRIC.

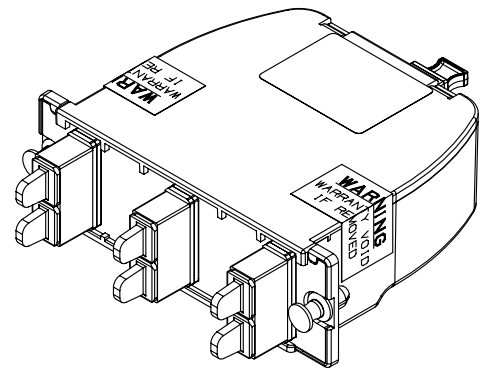

					TITLE 6 FIBER DUPLEX SC CASSETTE METHOD A AND MODIFIED METHOD A, PAIR FLIPPED							
					CUSTOMER DRAWING							
					ITEM REVISION NAME 10F113AE/00							
					DATASET FILE NAME 10F113AE_DC/00A							
					UNLESS OTHERWISE SPECIFIED, DIMENSIONAL TOLERANCES ARE: IN [mm]							
					.x ± .03 [.8] .xxx ± .005 [.127] .xx ± .01 [.25] ANGLES ± 5 °							
					THIRD ANGLE PROJECTION							
					DRAWING NUMBER: 10F113AE-DC							
R 10-10-12 SAT TMSE					RELEASED TO PRODUCTION							
					10F113AE-DC							
REV	DATE	BY	CHK	APR	DESCRIPTION	ECN	DRAWN BY	DATE	CHK	SCALE	DRAWING NUMBER	SIZE
							SAT	10-01-12	TMSE	NONE	SHT 1 OF 3	A

THIS COPY IS PROVIDED ON A RESTRICTED BASIS AND IS NOT TO BE USED IN ANY WAY DETRIMENTAL TO THE INTERESTS OF PANDUIT CORP.

6 FIBER DUPLEX SC CASSETTE - METHOD A

PART NUMBER	DESCRIPTION
FC2Z0-06-03AS	6 FIBER 50/125um OM4 OPTIMIZED
FC2ZN-06-03AS	6 FIBER 50/125um OM4
FC2X0-06-03AS	6 FIBER 50/125um OM3 OPTIMIZED
FC2XN-06-03AS	6 FIBER 50/125um OM3
FC25N-06-03AS	6 FIBER 50/125um OM2
FC26N-06-03AS	6 FIBER 62.5/125um OM1
FC29N-06-03AS	6 FIBER 9/125um OS1/OS2
FC2SA-06-03AS	6 FIBER 50/125um OM4+, SIGNATURE CORE

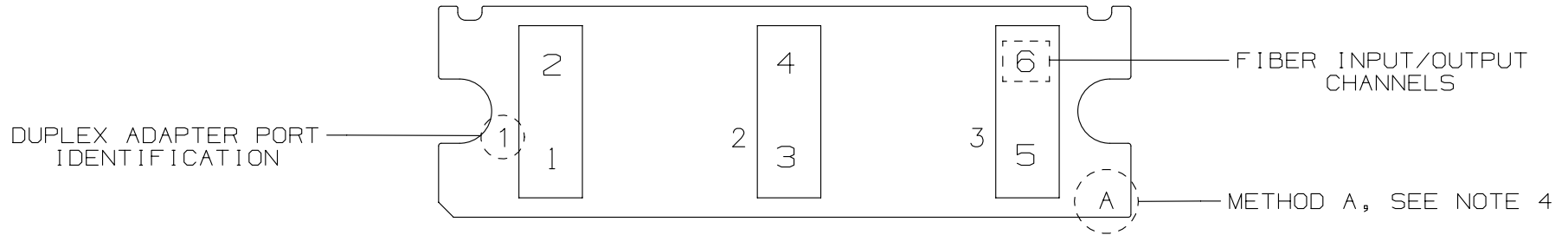

METHOD A - FIBER LAYOUT

REV	DATE	BY	CHK	APR	DESCRIPTION	ECN	DRAWN BY	DATE	CHK	SCALE	DRAWING NUMBER	SIZE
R	10-10-12	SAT	TMSE		RELEASED TO PRODUCTION	10F113AE-DC						
							SAT	10-01-12	TMSE	NONE	SHT 2 OF 3	A

TITLE		6 FIBER DUPLEX SC CASSETTE METHOD A
CUSTOMER DRAWING		
ITEM REVISION NAME	10F113AE/00	
DATASET FILE NAME	10F113AE_DC/00A	
UNLESS OTHERWISE SPECIFIED, DIMENSIONAL TOLERANCES ARE: IN (mm)		
.x ± .03 (.8)	.xxx ± .005 (.127)	MATERIAL: SEE NOTES SHEET 1
.xx ± .01 (.25)	ANGLES ± 5°	
THIRD ANGLE PROJECTION		DRAWING NUMBER: 10F113AE-DC

