

Tige fileté M6 + 2 Ecrou HE M6  
(Threaded rod M6 + 2 Nut M6)

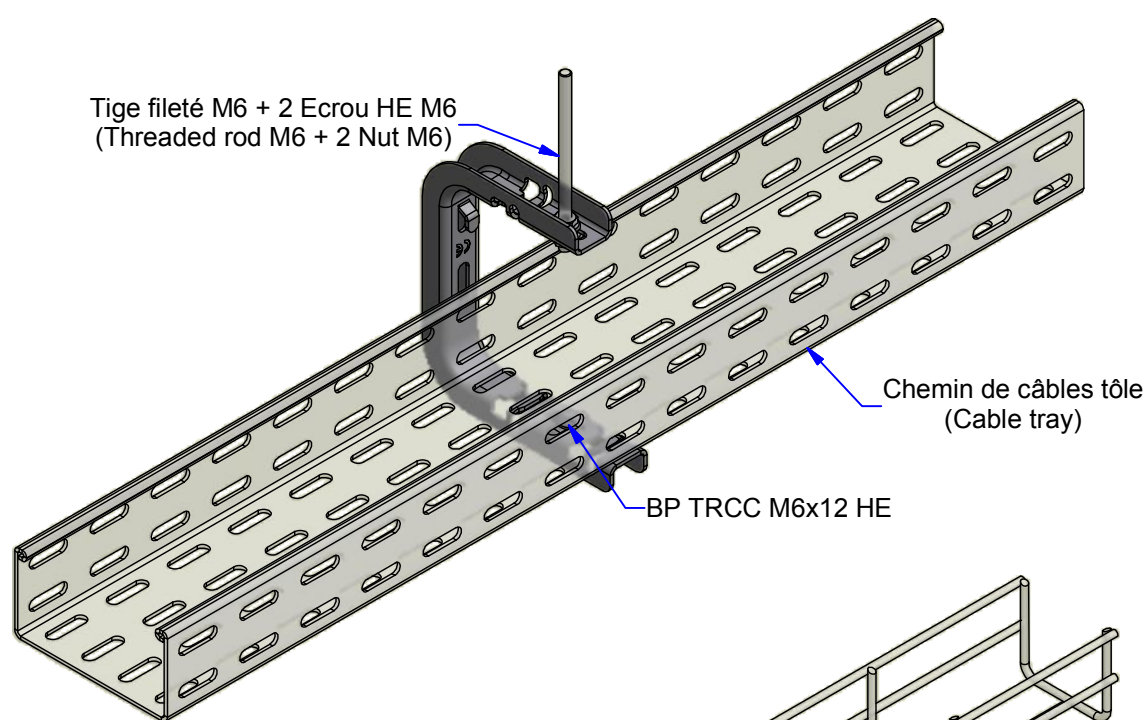

Chemin de câbles tôle  
(Cable tray)

BP TRCC M6x12 HE

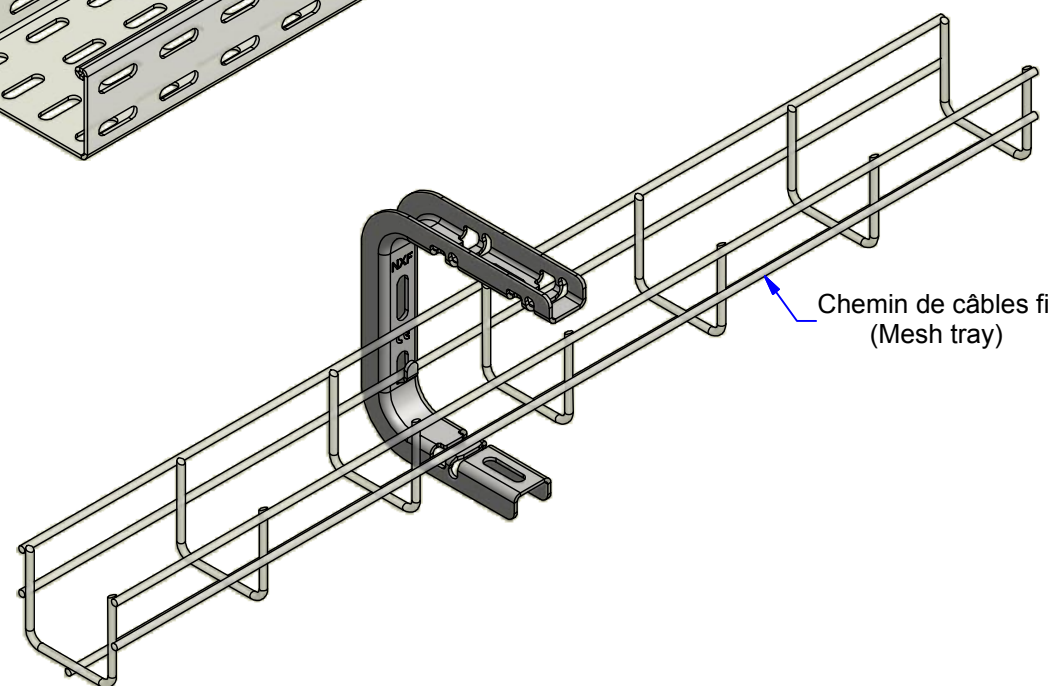

Chemin de câbles fil  
(Mesh tray)

Description	Code	Masse/Weight Kg/p	Ep./Th. mm	daN
SFT 50-100 SZ	747050	0,20	2,00	20

**G** : Pre-galvanised according to NF EN 10346 (S220 GD / Z).

**SZ** : Tôle d'acier galvanisé avant fabrication suivant NF EN 10346 (S220 GD / Z).



www.niedaxfrance.fr

SUPPORT SFT 50-100 SZ  
BRACKET SFT 50-100 G



ASSISTANCE TECHNIQUE  
+33 (0)1 55 95 92 17  
pole.technique@niedax.fr

FT02992

**NIEDAX**  
France

