

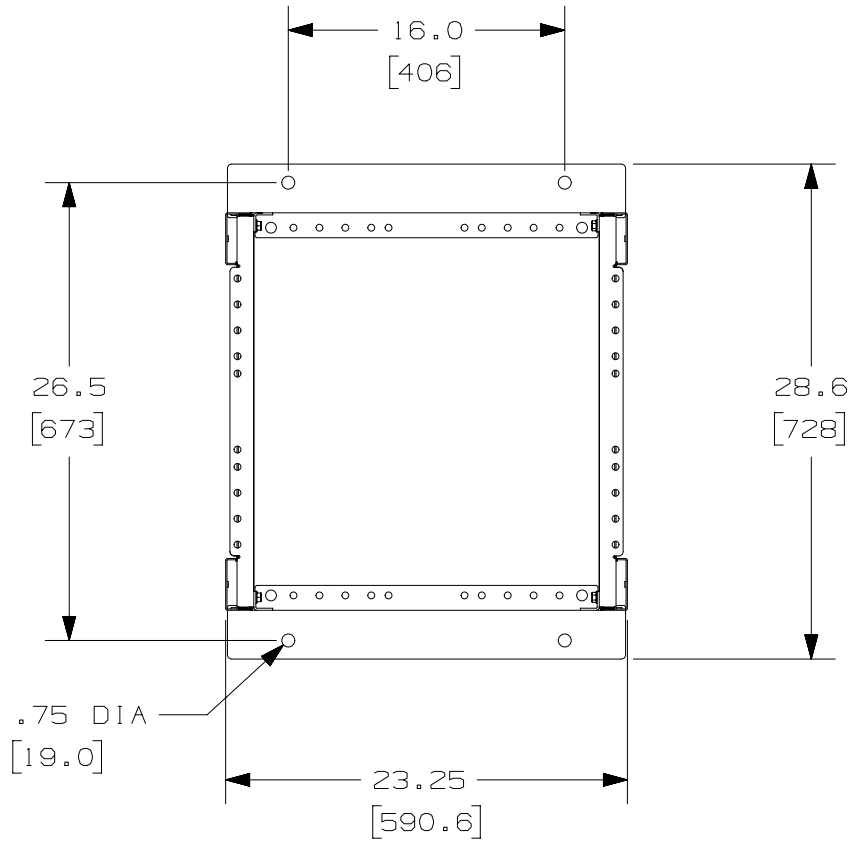

THIS COPY IS PROVIDED ON A RESTRICTED BASIS AND IS NOT TO BE USED IN ANY WAY DETRIMENTAL TO THE INTERESTS OF PANDUIT CORP.

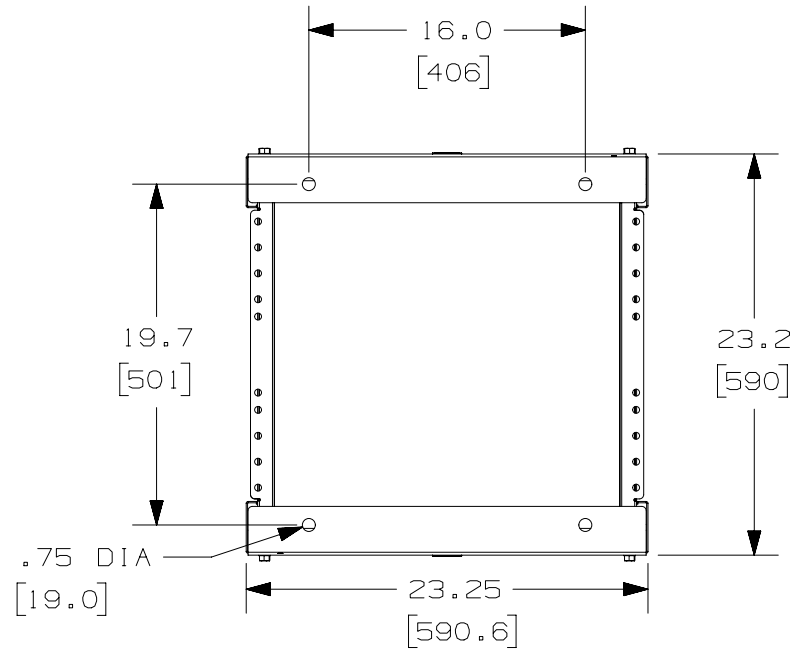

FLOOR FOOTPRINT WITH  
BASE ANGLES TURNED  
OUTWARD FOR EXTENDED  
FOOTPRINT



FLOOR FOOTPRINT WITH  
BASE ANGLES TURNED INWARD

06A	7-18-16	AMF	BAME	KRKE	SEE SHEET 1 OF 3 FOR REVISIONS	M09000EF
05A	11-11-13	PM	BAME	CMK	SEE SHEET 1 OF 3 FOR REVISIONS	V10679AV-DC
04A	3-3-11	BAME	SRK	CMK	SEE SHEET 1 OF 3 FOR REVISIONS	V10679AV-DC
03B	3-30-10	PBS	DPN	CMK	SEE SHEET 1 OF 3 FOR REVISIONS	V10679AV-DC
03A	10-9-09	BAME	DSI	CMK	SEE SHEET 1 OF 3 FOR REVISIONS	V10679AV-DC
02A	3-31-09	BAME	DSI	CMK	SEE SHEET 1 OF 3 FOR REVISIONS	V10679AV-DC

REV	DATE	BY	CHK	APR	DESCRIPTION	ECN
		BAME				

TITLE							23" DEEP 4 POST RACK (R4P23/R4P23CN) CUSTOMER DRAWING		
ITEM REVISION NAME							V10679AV/06		
DATASET FILE NAME							V10679AV_DC/06A		
UNLESS OTHERWISE SPECIFIED, DIMENSIONAL TOLERANCES ARE: IN ( mm )							MATERIAL:  STEEL		
.X ± .XX ±							.XXX ± ANGLES ±		
							THIRD ANGLE PROJECTION		
DRAWN BY		DATE		CHK		SCALE		DRAWING NUMBER:	
BAME		3-31-09		DSI		NONE		V10679AV-DC	
SHT 2 OF 3								SIZE A	

D10100DA/16

THIS COPY IS PROVIDED ON A RESTRICTED BASIS AND IS NOT TO BE USED IN ANY WAY DETRIMENTAL TO THE INTERESTS OF PANDUIT CORP.

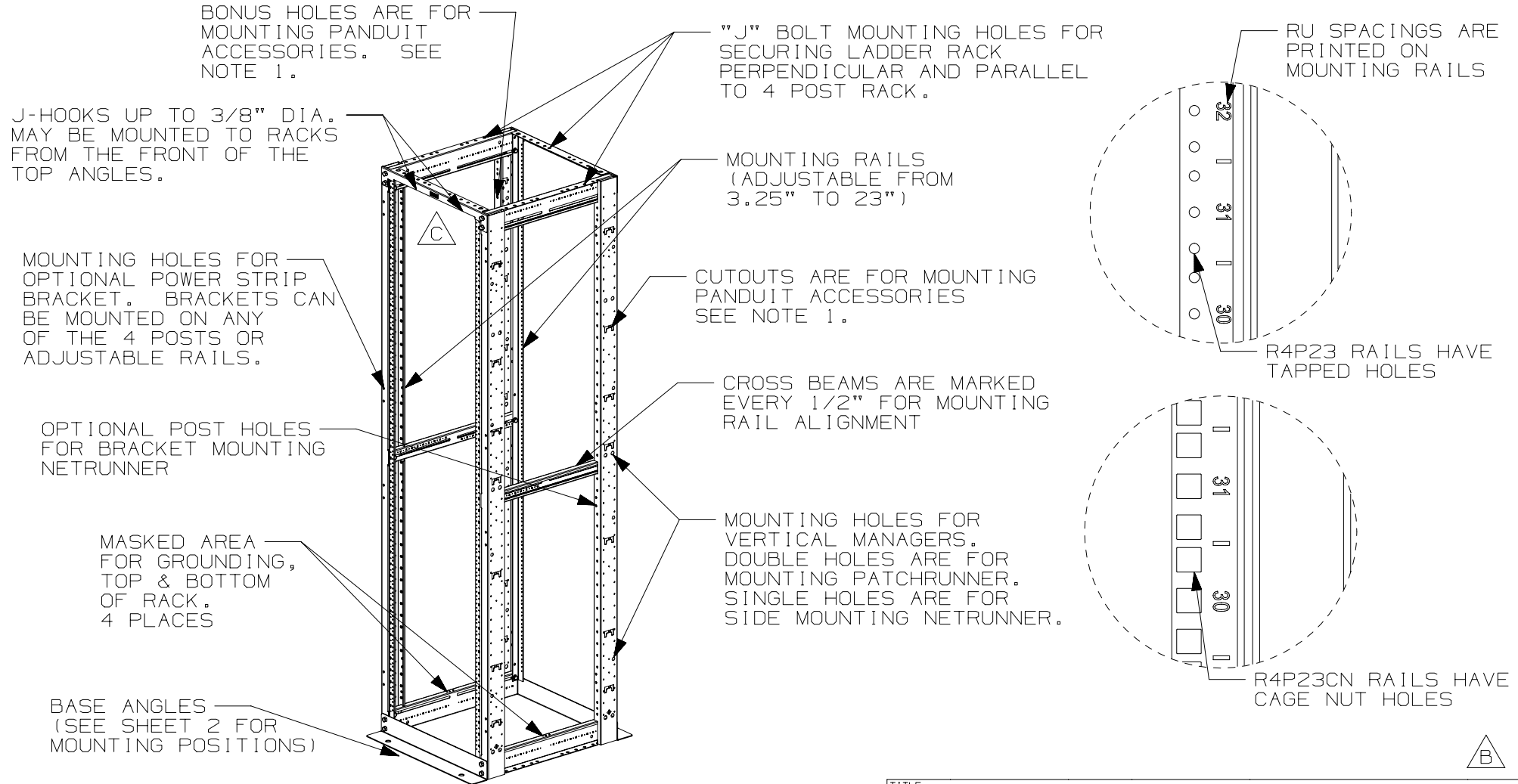

TITLE		<b>23" DEEP 4 POST RACK (R4P23/R4P23CN)</b>	
ITEM REVISION NAME		CUSTOMER DRAWING	
DATASET FILE NAME		<b>PANDUIT</b>	
UNLESS OTHERWISE SPECIFIED, DIMENSIONAL TOLERANCES ARE: IN (mm)		MATERIAL:	
.xxx ± ANGLES ±		STEEL	
THIRD ANGLE PROJECTION		DRAWING NUMBER:	
DRAWN BY: <b>BAME</b>		V10679AV-DC	
DATE: <b>3-31-09</b>	CHK: <b>DSI</b>	SCALE: <b>NONE</b>	SHT 3 OF 3
REV	DATE	BY	CHK
APR	DESCRIPTION	ECN	SIZE

06A	7-12-16	AMF	BAME	KRKE	SEE SHEET 1 OF 3 FOR REVISIONS	M09000EF
05A	11-11-13	PM	BAME	CMK	SEE SHEET 1 OF 3 FOR REVISIONS	V10679AV-DC
04A	3-3-11	BAME	SRK	CMK	SEE SHEET 1 OF 3 FOR REVISIONS	V10679AV-DC
03B	3-30-10	PBS	DPN	CMK	SEE SHEET 1 OF 3 FOR REVISIONS	V10679AV-DC
03A	10-9-09	BAME	DSI	CMK	SEE SHEET 1 OF 3 FOR REVISIONS	V10679AV-DC
02A	3-31-09	BAME	DSI	CMK	SEE SHEET 1 OF 3 FOR REVISIONS	V10679AV-DC

D10100DA/16