



Industrial Distribution Frame and Universal Distribution Frame Thermal Management

Network enclosures are widely used both indoors and outdoors to secure a wide range of electronic equipment such as switches, routers, gateways, power supplies, etc. These enclosures are used in a wide range of markets including hospitals, manufacturing plants, refineries, stadiums, etc. Therefore, these enclosures are exposed to a wide variety of ambient conditions.

Such enclosures (Figure 1) can have strict ingress ratings such as NEMA 4/4X, IP54/55, etc. These ratings, while protecting the equipment from some environmental conditions (dust, water spray, etc.), also effectively trap the heat dissipated by the active equipment inside the enclosure. This air, that has increased in temperature, must still provide adequate cooling for the components mounted inside the enclosure.

This application guide gives an overview of key design considerations for thermal management solutions to mitigate these thermal factors for Panduit’s UDF and IDF enclosures. The capabilities of the various thermal management solutions are discussed and guidelines for recommended solutions are provided.

Table of Contents

Application Guide	1
Introduction	2
12 RU IDF/UDF Thermal Solutions	2 – 3
Deploying a Fresh Air/Vented Cooling System in a 12 RU IDF/UDF	4
Deploying a T20 Air Conditioner in a 12 RU IDF/UDF	4
26 RU IDF/UDF Thermal Solutions	5 – 6
Deploying a Fresh Air/Vented Cooling System in a 26 RU IDF/UDF	7
Deploying a N28 Air Conditioner in a 26 RU IDF/UDF	8
Rack Mounted IT Equipment	8
Panduit Difference	8
References	8

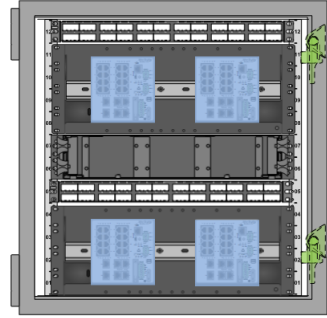

Figure 1: UDF 12 RU Universal Distribution Frame (front door removed).

The Information Contained In This Application Guide Is Intended As A Guide For Use By Persons Having Technical Skill At Their Own Discretion And Risk. Before Using Any Panduit Product, The Buyer Must Determine The Suitability Of The Product For His/Her Intended Use And Buyer Assumes All Risk And Liability Whatsoever In Connection Therewith. Panduit Disclaims Any Liability Arising From Any Information Contained Herein Or For Absence Of The Same.

Introduction

Most of the power consumed by electronic endpoint devices is dissipated as heat; this is especially true of IT equipment (switches, servers, routers, etc.). To avoid equipment overheating or even failure, the cooling of this equipment should be considered as part of the deployment plan. When an enclosure is placed in a high ambient temperature environment, this choice further increases the need to consider cooling options for any enclosure. Given the stringent sealing requirements for NEMA rated enclosures, the air inside is completely enclosed, severely limiting the options for cooling the air. Some of the current cooling solutions in the market use fans and vents, small enclosure mounted air conditioners, liquid-cooled heat exchangers, compressed air vortex tubes, etc. In the solutions section of this document, some of the more practical thermal management solutions will be considered for Panduit's Universal Distribution Frame (UDF) and Industrial Distribution Frame (IDF) enclosures.

The solutions are based on maintaining the internal temperature of the enclosure below 60°C. This is the upper temperature limit for most of the components in a typical UDF or IDF deployment with DIN rail mounted equipment.

The charts in the following sections illustrate the allowable ambient temperature outside an enclosure vs. a heat load for various recommended cooling solutions.

12 RU IDF/UDF Thermal Solutions

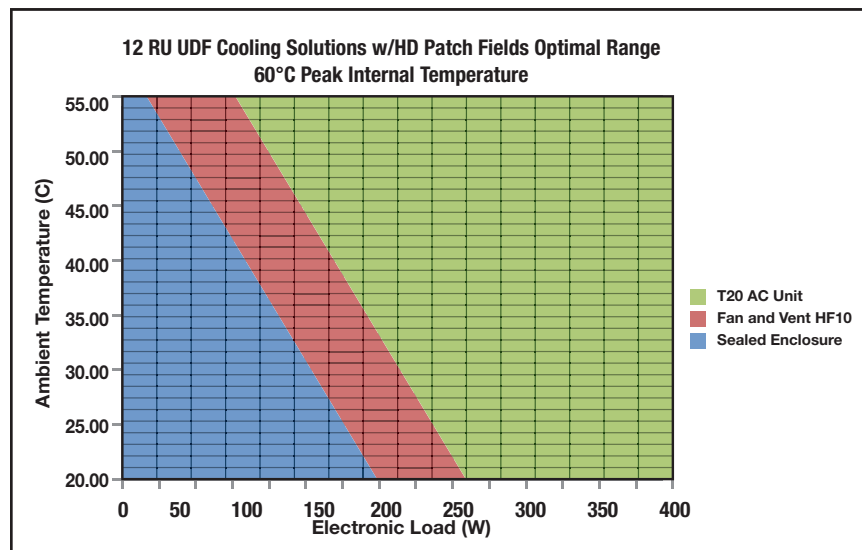

Figure 2: 12 RU UDF enclosure guidelines for three recommended thermal solutions. The examples below demonstrate how to use this graph.

Example 1: An electronic load of 100 watts (sum of heat dissipation of the electronics inside the UDF). A peak ambient temperature of 35°C (temperature outside the enclosure).

Answer 1: The intersection of the vertical 100 w line and the horizontal 35°C line is in the blue area. Therefore, the UDF enclosure will adequately dissipate the heat and the peak internal temperature inside the UDF will not exceed 60°C.

Example 2: An electronic load of 150 watts. A peak ambient temperature of 35°C (temperature outside the enclosure).

Answer 2: The intersection of the vertical 150 w line and the horizontal 35°C line is in the red area. Therefore, a fan and vent are required to keep the internal temperature of the UDF enclosure below 60°C.

Example 3: An electronic load of 200 watts. A peak ambient temperature of 40°C (temperature outside the enclosure).

Answer 3: The intersection of the vertical 200 w line and the horizontal 40°C line is in the green area. Therefore, a T20 air conditioner is required to keep the internal temperature of the UDF enclosure below 60°C.

Notes: Installing a fan and vent or air conditioner lowers the enclosure rating to IP54/IP55.

Installing DIN rail mounted equipment with an operating temperature less than 60°C will likely require an air conditioner to avoid exceeding the temperature limits for the device in question (e.g. battery UPS).

Follow vendor recommendations for minimum clearances around active equipment (e.g. typically 2" for convection cooled switches). Mount equipment with lower recommended operating temperatures on the lower DIN rails.

12 RU IDF/UDF Thermal Solutions (continued)

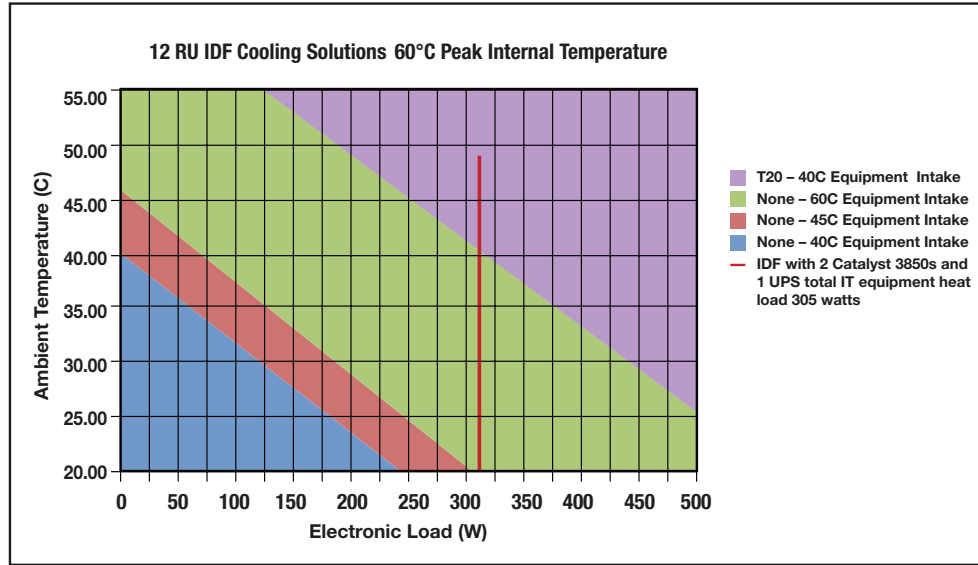

Figure 3: 12 RU IDF enclosure guidelines for recommended thermal solutions. This graph is used in the same manner as the graph shown in Figure 2.

Notes: Installing a fan and vent or air conditioner lowers the enclosure rating to IP54/IP55.

Installing DIN rail mounted equipment with an operating temperature less than 60°C will likely require an air conditioner to avoid exceeding the temperature limits for the device in question (e.g. battery UPS).

Follow vendor recommendations for minimum clearances around active equipment (e.g. typically 2" for convection cooled switches). Mount equipment with lower recommended operating temperatures on the lower DIN rails or racks.

Deploying a Fresh Air/Vented Cooling System in a 12 RU IDF/UDF

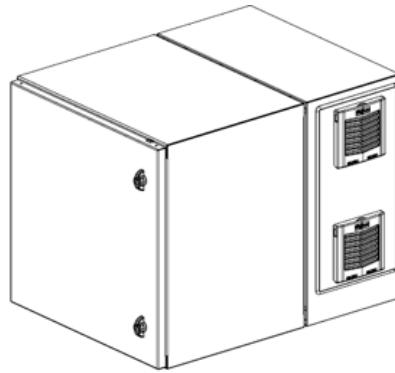

Figure 4: 12 RU UDF enclosure with vent and fan installed on the gland plate. The fan should be installed in the lower position and the vent in the upper position. Reversing the locations of the fan and vent may reduce thermal performance.

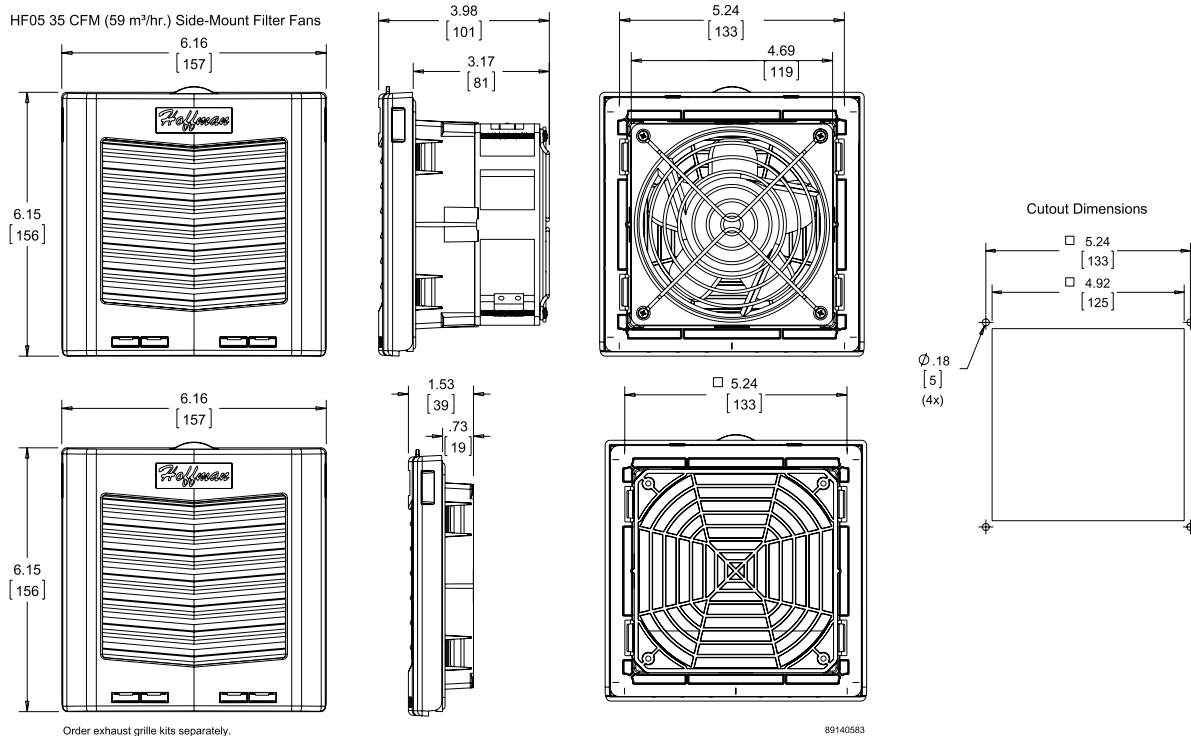

Figure 5: Dimensions of a HF05 exhaust fan and exhaust vent and cutout dimensions. The gland plate should be removed, and the fan and vent cutouts made in the gland plate. These cutouts must be aligned with the openings already provided in the enclosure for the T20 air conditioner. Mount the fan and vent to the gland plate then reattach the gland plate to the enclosure.

Deploying a T20 Air Conditioner in a 12 RU IDF/UDF

The HF05 fans, vents, and the T20 air conditioner are provided separately from nVent|Hoffman. Complete installation and operating guides are provided by the manufacturer. Links to these installation documents are provided in the reference section.

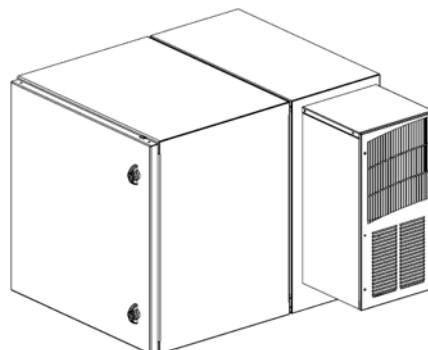

Figure 6: 12 RU UDF shown with a T20 AC unit. Remove the gland plate and mount the air conditioner aligned to the holes provided in the enclosure. The gland plate is not required once the air conditioner is installed on the enclosure.

26 RU IDF/UDF Thermal Solutions

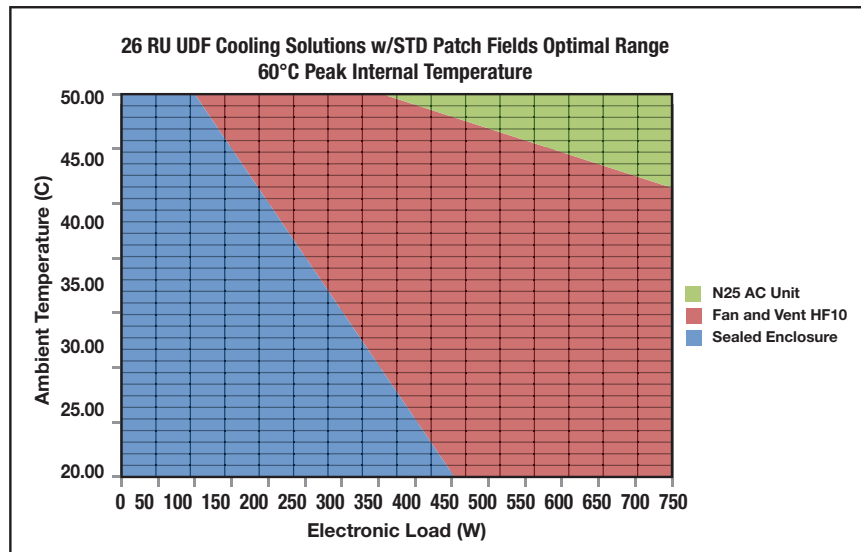

Figure 7: 26 RU UDF enclosure guidelines for three recommended thermal solutions. The examples below demonstrate how to use this graph

Example 1: An electronic load of 200 watts (sum of heat dissipation of the electronics inside the UDF). A peak ambient temperature of 35°C (temperature outside the enclosure).

Answer 1: The intersection of the vertical 200 w line and the horizontal 35°C line is in the blue area. Therefore, the UDF enclosure will adequately dissipate the heat and the peak internal temperature inside the UDF will not exceed 60 °C.

Example 2: An electronic load of 300 watts. A peak ambient temperature of 40°C (temperature outside the enclosure).

Answer 2: The intersection of the vertical 300 w line and the horizontal 40°C line is in the red area. Therefore, a fan and vent are required to keep the internal temperature of the UDF enclosure below 60°C.

Example 3: An electronic load of 550 watts. A peak ambient temperature of 50°C (temperature outside the enclosure).

Answer 3: The intersection of the vertical 550 w line and the horizontal 50°C line is in the green area. Therefore, a N28 air conditioner is required to keep the internal temperature of the UDF enclosure below 60°C.

Notes: Installing a fan and vent or air conditioner lowers the enclosure rating to IP54/IP55.

Installing equipment with an operating temperature less than 60°C will likely require an air conditioner to avoid exceeding the temperature limits for the device in question (e.g. battery UPS).

Follow vendor recommendations for minimum clearances around active equipment (e.g. typically 2" for convection cooled switches). Mount equipment with lower recommended operating temperatures on the lower DIN rails.

26 RU IDF/UDF Thermal Solutions (continued)

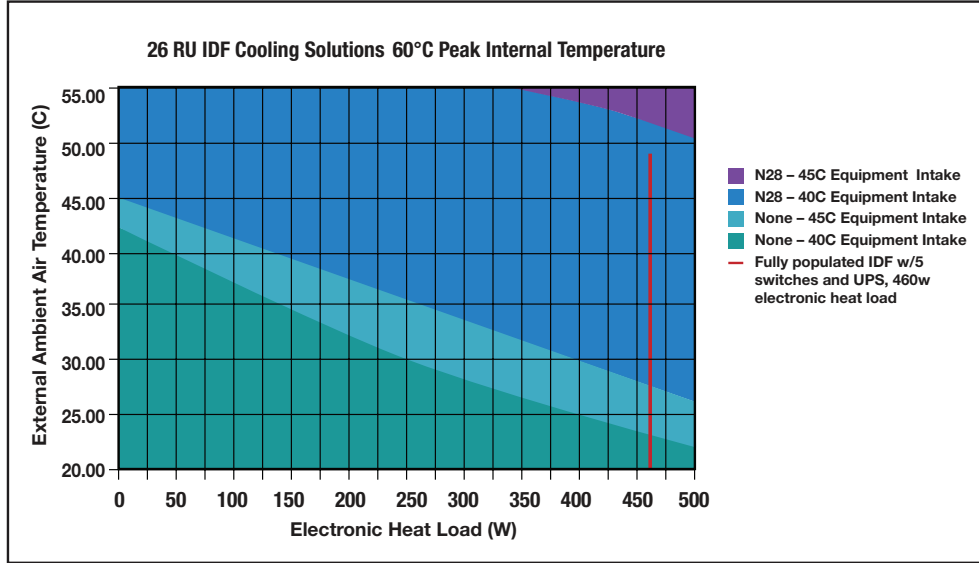

Figure 8: 26 RU IDF enclosure guidelines for recommended thermal solutions. This graph is used in the same manner as the graph shown in Figure 8.

Notes: Installing a fan and vent or air conditioner lowers the enclosure rating to IP54/IP55.

Installing equipment with an operating temperature less than 60°C will likely require an air conditioner to avoid exceeding the temperature limits for the device in question (e.g. battery UPS).

Follow vendor recommendations for minimum clearances around active equipment (e.g. typically 2" for convection cooled switches). Mount equipment with lower recommended operating temperatures on the lower racks.

Deploying a Fresh Air/Vented Cooling System in a 26 RU IDF/UDF

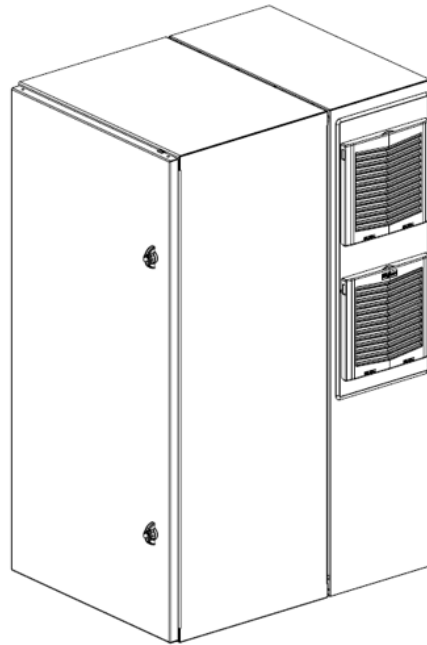

Figure 9: 26 RU UDF enclosure with vent and fan installed. The fan should be installed in the lower position and the vent in the upper position. Reversing the locations of the fan and vent may reduce thermal performance.

HF10 159 CFM (270 m³/Hr.) Side-Mount Filter Fans

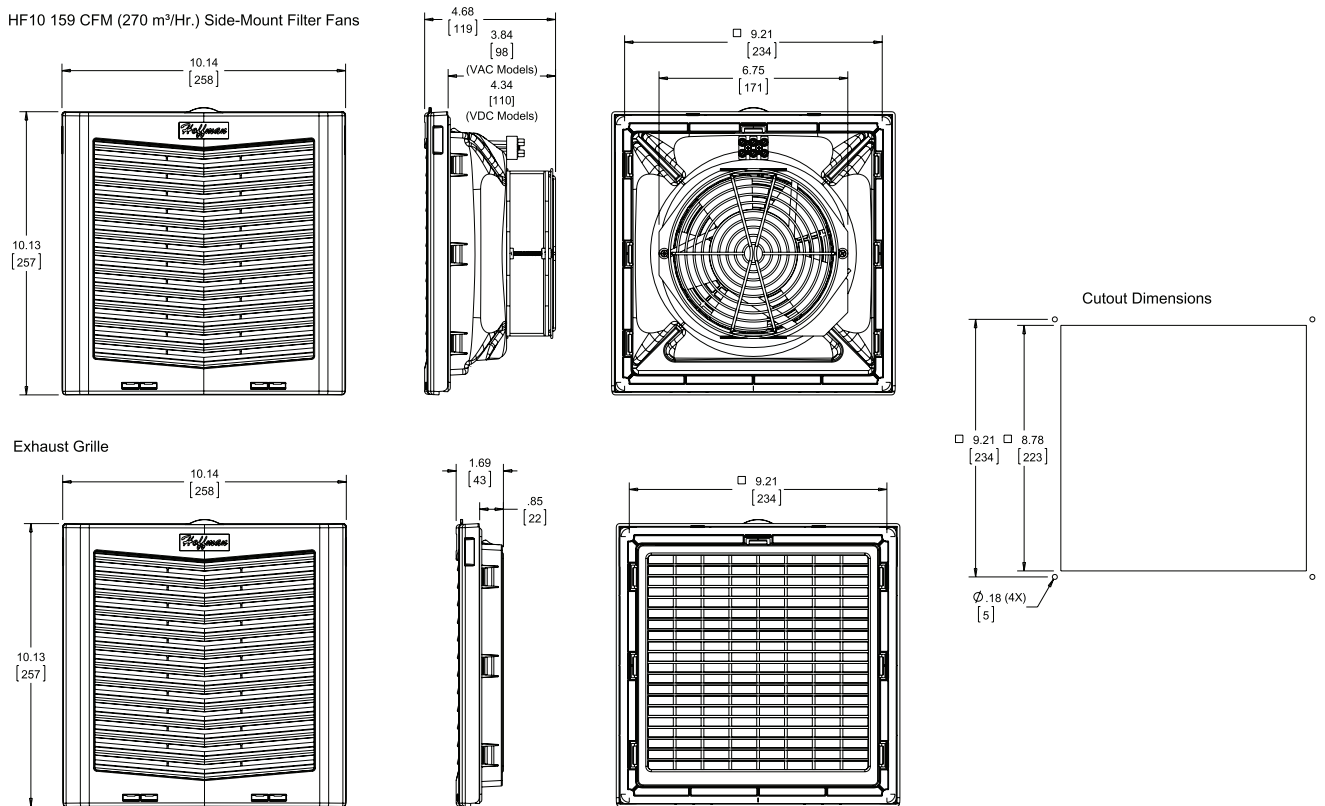

Figure 10: Dimensions of a HF10 exhaust fan and exhaust vent and cutout dimensions. The gland plate should be removed, and the fan and vent cutouts made in the gland plate. The fan and vent cutouts must be aligned with the openings already provided in the enclosure for the N28 air conditioner. Mount the fan and vent to the gland plate then reattach the gland plate to the enclosure.



Deploying a N28 Air Conditioner in a 26 RU IDF/UDF

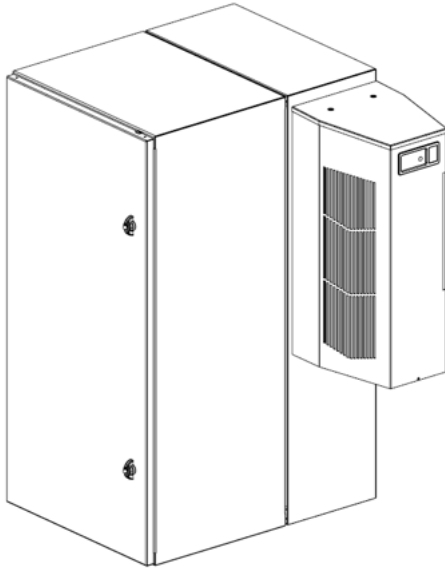

Figure 11: 26 RU UDF shown with a N28 AC unit. Remove the gland plate and mount the air conditioner aligned to the cutouts provided in the enclosure. The gland plate is not required once the air conditioner is installed on the enclosure.

The HF10 fans, vents and the N28 air conditioner are provided separately from nVent|Hoffman. Complete installation and operating guides are provided by the manufacturer. Links to these installation documents are provided in the reference section.

Rack Mounted IT Equipment

Installing a mix of DIN rail mounted equipment and rack mounted equipment is not recommended since rack mounted equipment typically has lower operating temperatures (30 to 45 °C).

However, if a mix of DIN rail and rack mounted equipment is required for a deployment the following are some general thermal guidelines:

- Remove the lowest tier and install the rack mounted equipment in the rack units below the remaining DIN rail tier(s).
- The lower operating temperature of rack mounted equipment typically require a fan and vent or an air conditioner to maintain acceptable internal temperatures for the active equipment inside the enclosure.
- Even with only rack mounted equipment installed in a UDF or IDF, the lower operating temperature range of this equipment typically requires a fresh air or AC unit to maintain acceptable temperatures inside a sealed enclosure.
- The depth of rack mounted equipment may result in installation issues. Verify adequate clearance is available in the UDF or IDF enclosure for the rack mounted equipment before deployment.

Panduit Difference

Panduit is committed to delivering a consistently high level of quality and service the world over. With a presence in more than 100 countries, local Panduit sales representatives and technical specialists offer guidance and support that bring value to your business. Our global supply chain, which includes manufacturing, customer service, logistics, and distribution partners, provides prompt response to your inquiries and streamlines delivery to any worldwide destination.

References

1. <https://enclosures.nvent.com/wcsstore/ExtendedSitesCatalogAssetStore/Attachment/HoffmanProductAttachments/SpecSheets/Spec-01170.pdf>
2. <https://enclosures.nvent.com/wcsstore/ExtendedSitesCatalogAssetStore/Attachment/HoffmanProductAttachments/InstructionManuals/89134973.pdf>
3. <https://enclosures.nvent.com/wcsstore/ExtendedSitesCatalogAssetStore/Attachment/HoffmanProductAttachments/SpecSheets/Spec-00733.pdf>
4. <https://enclosures.nvent.com/wcsstore/ExtendedSitesCatalogAssetStore/Attachment/HoffmanProductAttachments/InstructionManuals/89114993.pdf>
5. <https://hoffman.nvent.com/>
6. <https://hoffman.nvent.com/wcsstore/ExtendedSitesCatalogAssetStore/Attachment/HoffmanProductAttachments/InstructionManuals/89115550.pdf>

WORLDWIDE SUBSIDIARIES AND SALES OFFICES

PANDUIT US/CANADA
Phone: 800.777.3300

PANDUIT EUROPE LTD.
London, UK
Phone: 44.20.8601.7200

PANDUIT SINGAPORE PTE. LTD.
Republic of Singapore
Phone: 65.6305.7575

PANDUIT JAPAN
Tokyo, Japan
Phone: 81.3.6863.6000

PANDUIT LATIN AMERICA
Guadalajara, Mexico
Phone: 52.33.3777.6000

PANDUIT AUSTRALIA PTY. LTD.
Victoria, Australia
Phone: 61.3.9794.9020

For a copy of Panduit product warranties, log on to www.panduit.com/warranty

For more information

Visit us at www.panduit.com

Contact Customer Service by email: cs@panduit.com
or by phone: 800.777.3300



© 2020 Panduit Corp.
ALL RIGHTS RESERVED.
ZCAG02--SA-ENG
6/20