

This is a controlled document.  
 Hardcopy to be endorsed by authorized person.  
 Check with Issuing Office or SAP system for latest update.

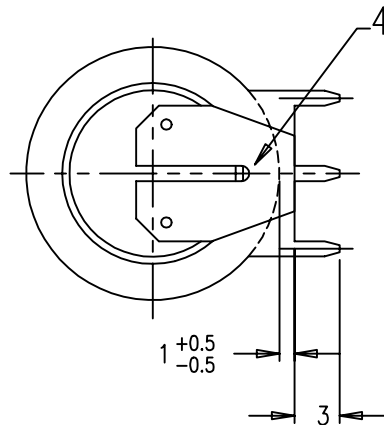
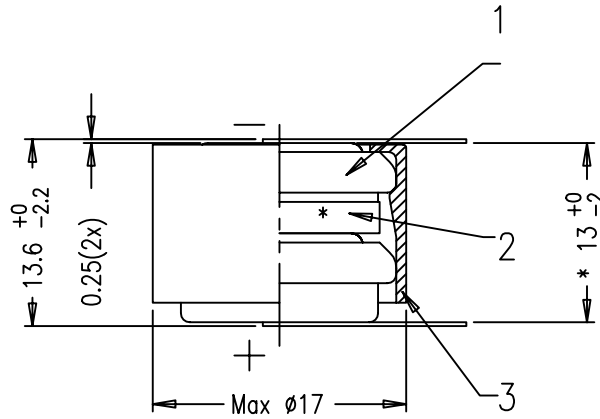
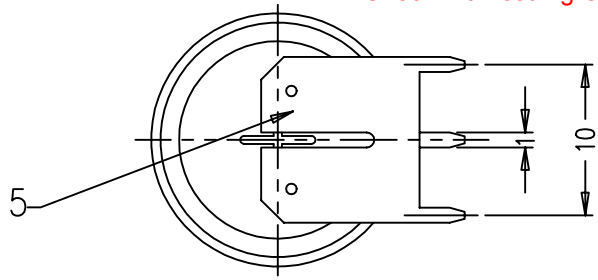

- Note: 1) No welding onto the groove  
 2) For typical PCB-application we recommend to use VARTA-Mempac batteries.  
 3)\* For reference only

Approximate weight of battery : 8.0g

No.	Alterations:	Date:	Name:	Dimensions in mm	Material:
				Tolerance: DIN 7168 Medium	Refer to part list no: 070971
				Projection:	Description:  2/V80H battery with snap-on plastic casing & solder tags
				Scale: 2 : 1	
				Date: Name:	
				Prepared: 1997-11-10 A.P.ANG	
				Approved: 2000-	

RIGHTS RESERVED TO MAKE TECHNICAL CHANGES, AS A RESULT OF FURTHER DEVELOPMENT, WITHOUT NOTICE. THIS DRAWING IS THE PROPERTY OF VARTA BATTERIES PTE LTD AND MUST NOT BE COPIED OR DISCLOSED TO A THIRD PARTY WITHOUT THE WRITTEN CONSENT OF VARTA BATTERIES PTE LTD.



Dwg. No:	070971	400
VKB Order No:	55608 602 059	
Orig No:		