

EDS35-0KF0A024A

EDS/EDM35

MOTOR FEEDBACK SYSTEMS ROTARY HIPERFACE DSL®

SICK
Sensor Intelligence.

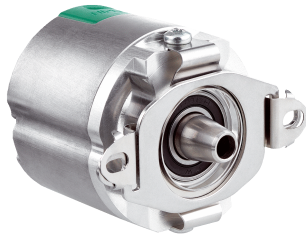

Illustration may differ



Ordering information

Type	Part no.
EDS35-0KF0A024A	1090732

Other models and accessories → www.sick.com/EDS_EDM35

Detailed technical data

Performance

Position	
Resolution per revolution	24 bit
System accuracy	± 25 " 1)
Signal noise (σ)	± 1 " 2)
Number of the absolute ascertainable revolutions	1
Available memory area	8,192 Byte

1) In accordance with DIN ISO 1319-1, position of the upper and lower error limit depends on the installation situation, specified value refers to a symmetrical position, i.e. deviation in upper and lower direction is the same.

2) Repeatability standard deviation in accordance with DIN 1319-1:1995.

Interfaces

Code sequence	Increasing, when turning the shaft For clockwise rotation, looking in direction "A" (see dimensional drawing)
Communication interface	HIPERFACE DSL®
Initialization time	≤ 500 ms 1)
Measurement external temperature resistance	32-bit value, without prefix (1 Ω) 0 ... 209.600 Ω 2)

1) From reaching a permitted operating voltage.

2) Without sensor tolerance; at -40 °C ... +160 °C: NTC +2K; PTC+3K (KTY84-130/PT1000). For additional conversion function of PT1000 to KTY84/130, see technical description.

Electrical data

Connection type	Male connector, 4-pin
Supply voltage	7 V ... 12 V
Warm-up time voltage ramp	Max. 180 ms 1)
Current consumption	≤ 150 mA 2)
MTTF: mean time to dangerous failure	145 years (EN ISO 13849) 3)

1) Duration of voltage ramp between 0 and 7.0 V.

2) Current rating applies when using interface circuit suggestions as shown in HIPERFACE DSL® manual (8017595).

3) This product is a standard product and does not constitute a safety component as defined in the Machinery Directive. Calculation based on nominal load of components, average ambient temperature 60 °C, frequency of use 8760 h/a. All electronic failures are considered hazardous. For more information, see document no. 8015532.

Mechanical data

Shaft version	Tapered shaft
Dimensions	See dimensional drawing
Weight	≤ 100 g
Moment of inertia of the rotor	5 gcm ²
Operating speed	≤ 12,000 min ⁻¹
Angular acceleration	≤ 250,000 rad/s ²
Start up torque	≤ 0.6 Ncm, +20 °C
Permissible movement static	± 1 mm axial ¹⁾
Permissible movement dynamic	± 0.1 mm radial
Life of ball bearings	50,000 h at 6,000 min ⁻¹ (at a flange temperature of 70 °C)

¹⁾ Temperature expansion, mechanical attachment.

Ambient data

Operating temperature range	-40 °C ... +115 °C ¹⁾
Storage temperature range	-40 °C ... +125 °C, without package
Relative humidity/condensation	90 %, Condensation not permitted
Resistance to shocks	100 g, 6 ms (according to EN 60068-2-27)
Frequency range of resistance to vibrations	50 g, 10 Hz ... 2,000 Hz (EN 60068-2-6)
EMC	According to EN 61000-6-2, EN 61000-6-4 and IEC 61326-3 ²⁾
Enclosure rating	IP40, When cover is closed and mating connector is attached (IEC 60529-1)

¹⁾ Given typical thermal connection between motor flange and encoder stator coupling. The max. internal sensor temperature may not exceed 125 °C.

²⁾ According to the listed standards, EMC is guaranteed if the motor feedback system with mating connector inserted is connected to the central grounding point of the motor controller via a cable shield. If other shielding concepts are used, users must perform their own tests. Class A device.

Classifications

ECLASS 5.0	27270590
ECLASS 5.1.4	27270590
ECLASS 6.0	27270590
ECLASS 6.2	27270590
ECLASS 7.0	27270590
ECLASS 8.0	27270590
ECLASS 8.1	27270590
ECLASS 9.0	27270590
ECLASS 10.0	27273805
ECLASS 11.0	27273901
ECLASS 12.0	27273901
ETIM 5.0	EC001486
ETIM 6.0	EC001486
ETIM 7.0	EC001486
ETIM 8.0	EC001486
UNSPSC 16.0901	41112113

Dimensional drawing (Dimensions in mm (inch))

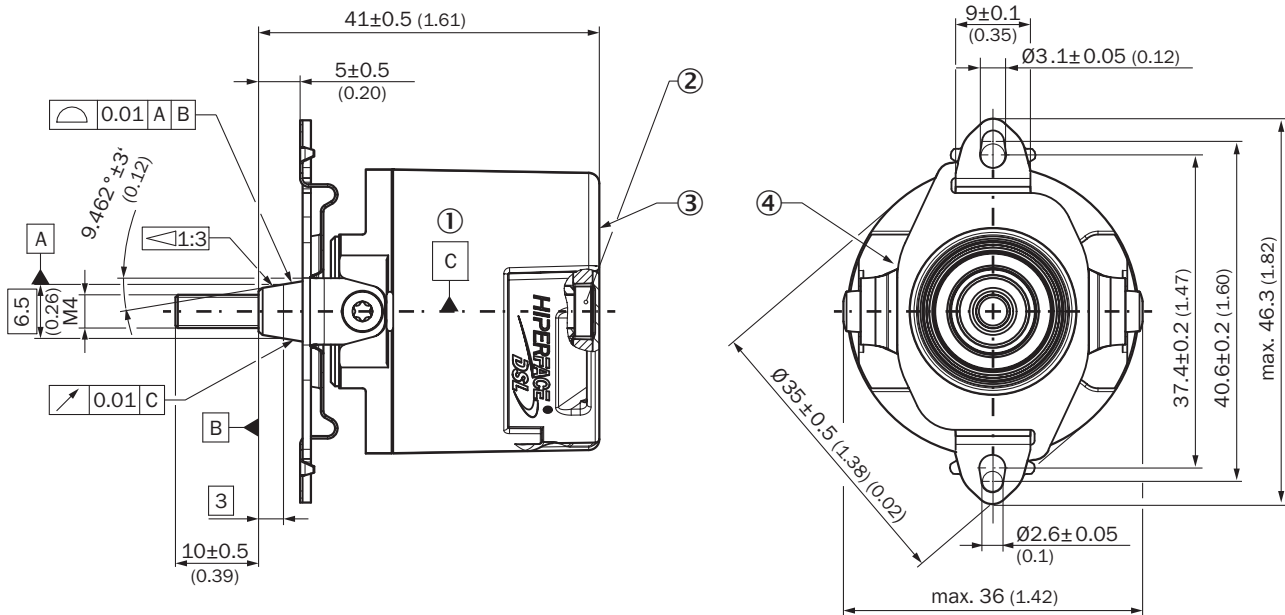

- ① Bearing of the encoder shaft
- ② Torx 15 cylinder screw
- ③ Measuring point for vibrations
- ④ Measuring point for operating temperature

Attachment specifications

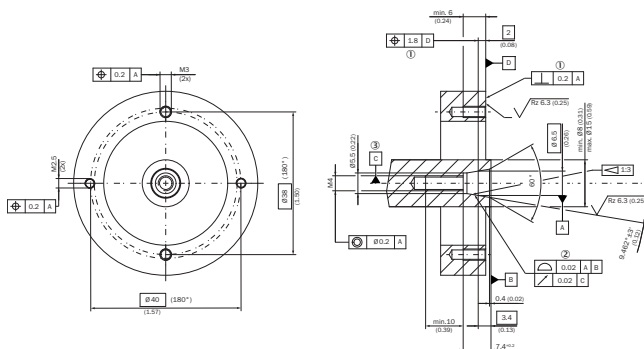

- ① Permanently
- ② Dynamic
- ③ Bearing of the drive shaft

PIN assignment

PIN assignment temperature sensor

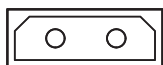

2 1

K connection type

PIN	Signal	Explanation
1	T+	Thermistor connection
2	T-	Thermistor connection (to ground)
Recommended outer diameter of set of stranded wires: 2.2 mm ± 0.1 mm		
Recommended mating connector: Harwin M80-8990205		

Supply / Communication pin assignment

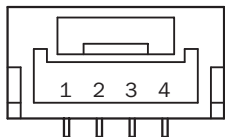

Integrated in motor cable = K

PIN	Signal	Explanation
1		Not connected - no function
2	+U _S /DSL+	Supply 7 V ... 12 V
3	GND/DSL-	Ground connection
4		Not connected - no function
Recommended outer diameter of set of stranded wires: 2.8 mm ±0.3 mm		
Recommended mating connector: JST (GHR-04V-S)		

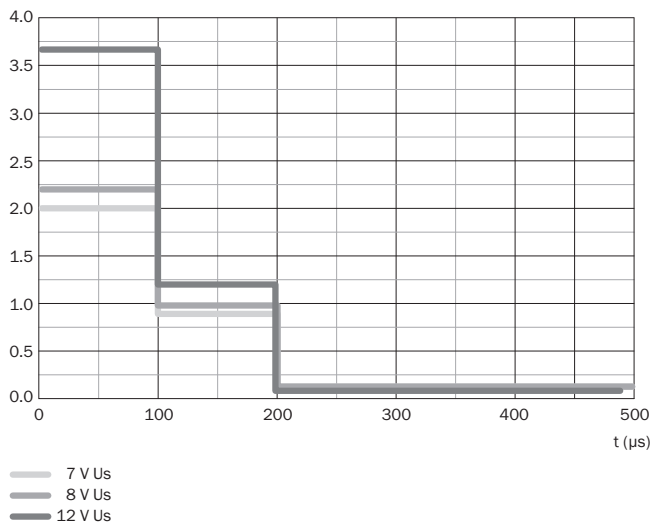

Diagrams

Typical inrush current (A)



Recommended accessories

Other models and accessories → www.sick.com/EDS_EDM35

	Brief description	Type	Part no.
Nuts and screws			
	500 pieces, Screws with Precote 85-8 coating; M4*48 (4093779)	BEF-MK-S09	2103244
	100 pieces, Screws with Precote 85-8 coating; M4*48 (4093779)	BEF-MK-S10	2103272
	10 pieces, Screws with Precote 85-8 coating; M4*48 (4093779)	BEF-MK-S11	2103274
Plug connectors and cables			
	<ul style="list-style-type: none"> • Connection type head A: Female connector, stranded wire, 4-pin, straight • Connection type head B: Flying leads • Signal type: HIPERFACE DSL® • Cable: 0.2 m, 2-wire • Description: HIPERFACE DSL®, unshielded 	DOL-0B02-G0M2XC2	2079920
	<ul style="list-style-type: none"> • Connection type head A: Female connector, stranded wire, 4-pin, straight • Connection type head B: Flying leads • Signal type: HIPERFACE DSL® • Cable: 0.36 m, 2-wire • Description: HIPERFACE DSL®, twisted, shielded 	DOL-0B02-G0M3AC2	2108944

SICK AT A GLANCE

SICK is one of the leading manufacturers of intelligent sensors and sensor solutions for industrial applications. A unique range of products and services creates the perfect basis for controlling processes securely and efficiently, protecting individuals from accidents and preventing damage to the environment.

We have extensive experience in a wide range of industries and understand their processes and requirements. With intelligent sensors, we can deliver exactly what our customers need. In application centers in Europe, Asia and North America, system solutions are tested and optimized in accordance with customer specifications. All this makes us a reliable supplier and development partner.

Comprehensive services complete our offering: SICK LifeTime Services provide support throughout the machine life cycle and ensure safety and productivity.

For us, that is “Sensor Intelligence.”

WORLDWIDE PRESENCE:

Contacts and other locations –www.sick.com