

THIS COPY IS PROVIDED ON A RESTRICTED BASIS AND IS NOT TO BE USED IN ANY WAY DETRIMENTAL TO THE INTERESTS OF PANDUIT CORP.

PANDUIT PART NO.	WEIGHT
FLEX-CM12S	0.75 lbs (0.34 kg)
FLEX-CM18S	

NOTES:

- SEE CATALOG FOR COMPLETE LIST OF PARTS APPLICABLE FOR USE WITH THIS PART.
- DIMENSIONS IN BRACKETS ARE METRIC.
- MATERIAL: GALVANNEALED STEEL
COLOR: BLACK
- INCLUDES 2 TRANSITION BUNDLING CLIPS.
(18 POSITION OR 12 POSITION CLIPS AVAILABLE)
- TRANSITION PANEL ATTACHES TO STANDARD EQUIPMENT MOUNTING RAILS OF RACK OR CABINET.
- MOUNTING HARDWARE INCLUDED.
- ALL MATERIALS AND COMPONENTS USED MEET THE MATERIAL RESTRICTIONS OF RoHS (EUROPEAN DIRECTIVE 2011/65/EC ON THE RESTRICTION OF HAZARDOUS SUBSTANCES) AS PROPOSED BY THE RoHS TECHNICAL ADAPTATION COMMITTEE.

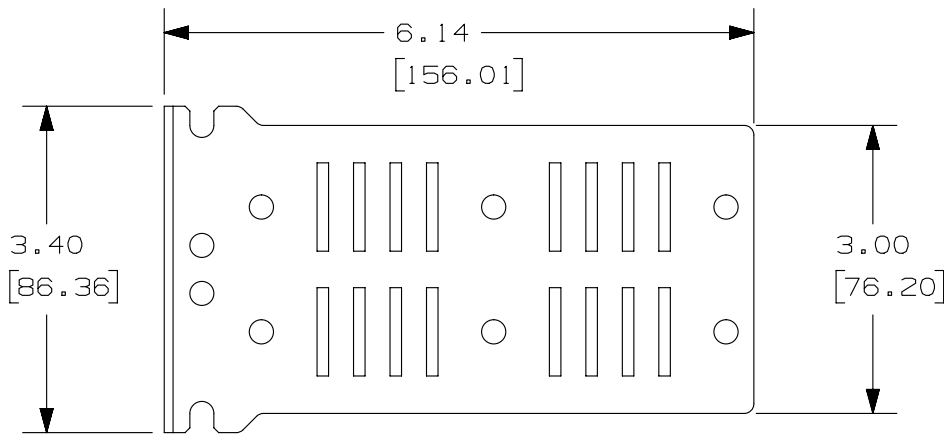

FRONT VIEW

LEFT SIDE VIEW

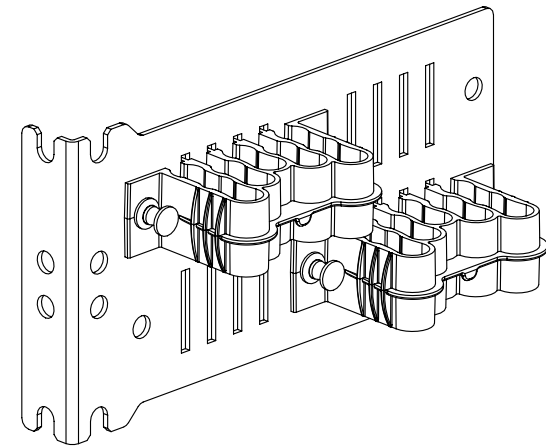

ISO VIEW
(12 POSITION BUNDLING CLIPS SHOWN)

REV	DATE	BY	CHK	APR	DESCRIPTION	ECN
00	01-13-15	SAT	BSN	TMK	RELEASED TO PRODUCTION	12F187JE-DC

TITLE		HD FLEX UNIVERSAL REAR CABLE MANAGER	
CUSTOMER DRAWING			
ITEM REVISION NAME		12F187JE/00	
DATASET FILE NAME		12F187JE_DC/00A	
UNLESS OTHERWISE SPECIFIED, DIMENSIONAL TOLERANCES ARE: IN (mm)			
.x ± .xx ± .03 (0.8) .xxx ± .010 (0.3) ANGLES ±			
PART NO.		SEE TABLE	
DRAWING NUMBER:		12F187JE-DC	
DRAWN BY	DATE	CHK	SCALE
SAT	01-13-15	BSN	1:2
SHT 1 OF 1		SIZE A	