

KSA80EZ5

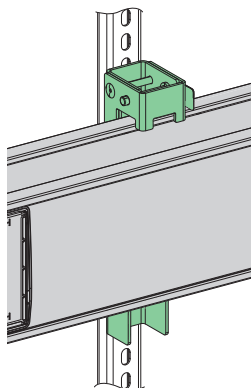

KSA80EZ53

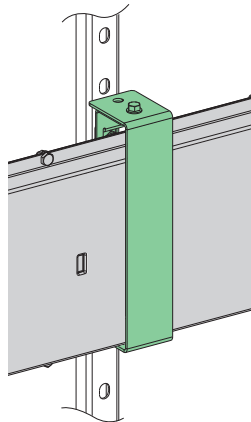

KSB400ZF1

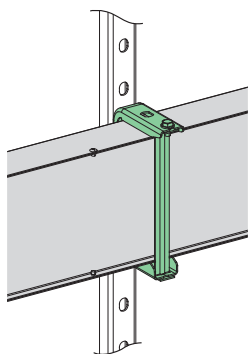

KSB1000ZF1

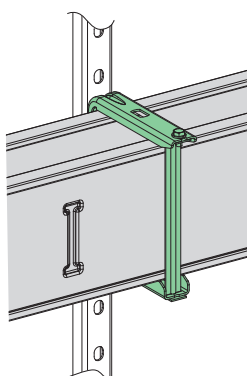

<p>PLEASE NOTE Electrical equipment should be installed, operated, serviced, and maintained only by qualified personnel. No responsibility is assumed by Schneider Electric for any consequences arising out of the use of this material.</p>	<p>REMARQUE IMPORTANTE L'installation, l'utilisation, la réparation et la maintenance des équipements électriques doivent être assurées par du personnel qualifié uniquement. Schneider Electric décline toute responsabilité quant aux conséquences de l'utilisation de cet appareil.</p>
--	---

<p>TENGA EN CUENTA La instalación, manejo, puesta en servicio y mantenimiento de equipos eléctricos deberán ser realizados sólo por personal cualificado. Schneider Electric no se hace responsable de ninguna de las consecuencias del uso de este material.</p>	<p>BITTE BEACHTEN Elektrische Geräte dürfen nur von Fachpersonal installiert, betrieben, bedient und gewartet werden. Schneider Electric haftet nicht für Schäden, die durch die Verwendung dieses Materials entstehen.</p>
--	--

<p>NOTA Manutenzione, riparazione, installazione e uso delle apparecchiature elettriche si devono affidare solo a personale qualificato. Schneider Electric non si assume alcuna responsabilità per qualsiasi conseguenza derivante dall'uso di questi prodotti.</p>	<p>NOTA A instalação, utilização e manutenção do equipamento eléctrico devem ser efectuadas exclusivamente por pessoal qualificado. A Schneider Electric não assume qualquer responsabilidade pelas consequências resultantes da utilização deste material.</p>
---	--

<p>请注意 电气设备的安装、操作、维修和维护工作仅限于合格人员执行。Schneider Electric不承担由于使用本资料所引起的任何后果。</p>	<p>ОБРАТИТЕ ВНИМАНИЕ Электрическое оборудование должно обслуживаться квалифицированным персоналом. Компания Schneider Electric не несет ответственности за последствия, связанные с использованием данной документации. Данная документация не предназначена для использования в качестве руководства людьми, не прошедшими какого-либо обучения.</p>
---	--

<p>Schneider Electric Industries SAS 35, rue Joseph Monier CS 30323 F - 92506 Rueil Malmaison Cedex</p> <p>© 2019 Schneider Electric -All rights reserved.</p>	<p>Уполномоченный поставщик в РФ: АО «Шнейдер Электрик» Адрес: 127018, г. Москва, ул. Двинцев, д. 12, корп.1, тел. +7 (495)777 99 88, факс: +7 (495)777 99 94, 8-800-200-6446 www.schneider-electric.ru</p> 
---	---

⚠ ⚠ DANGER / DANGER / PELIGRO / GEFAHR / PERICOLO / PERIGO / 危险 / ОПАСНО

<p>HAZARD OF ELECTRIC SHOCK, EXPLOSION, OR ARC FLASH Disconnect all power before servicing equipment. Failure to follow these instructions will result in death or serious injury.</p>	<p>RISQUE D'ÉLECTROCUTION, D'EXPLOSION OU D'ECLAIR D'ARC ÉLECTRIQUE Coupez toutes les alimentations avant de travailler sur cet appareil. Le non-respect de ces instructions provoquera la mort ou des blessures graves.</p>
--	--

<p>PELIGRO DE DESCARGA ELÉCTRICA, EXPLOSIÓN O ARCO ELÉCTRICO Desconecte todas las alimentaciones antes de manipular el producto. Si no se siguen estas instrucciones provocará lesiones graves o incluso la muerte.</p>	<p>GEFAHR VON ELEKTRISCHEM SCHLAG, EXPLOSION ODER LICHTBOGEN Vor dem Arbeiten am Gerät alle Spannungsversorgungen abschalten. Die Nichtbeachtung dieser Anweisungen führt zu Tod oder schwereren Verletzungen.</p>
---	--

<p>RISCHIO DI SCARICA ELETTRICA , ESPLOSIONE O ARCO ELETTRICO Scollegare l'apparecchio da tutti i circuiti di alimentazione prima di qualsiasi intervento. Il mancato rispetto di queste istruzioni provocherà morte o gravi infortuni.</p>	<p>RISCO DE ELECTROCUSSÃO, DE EXPLOSIÃO, OU DE ARCO ELÉCTRICO Desconecte todas as alimentações antes de manipular o produto. A não observância destas instruções resultará em morte, ou ferimentos graves.</p>
---	--

<p>电击、爆炸或电弧闪光危险 在此电力设备上工作时, 请先切断所有电源。不遵循上述说明将导致人员伤亡。</p>	<p>Опасность поражения электрическим током, опасность взрыва или вспышки дуги. Перед обслуживанием или ремонтом убедитесь, что питание отключено. Несоблюдение этих инструкций приведет к смерти или серьезной травме.</p>
---	--

**▲ CAUTION / ATTENTION / ATENCIÓN / VORSICHT /
ATTENZIONE / CUIDADO / 小心 / ВНИМАНИЕ**



RISK OF CUTTING

- Store the products in a dedicated and marked area.
 - Wear personal protective equipment when handling and installing the products (gloves, long sleeved jacket, trousers, safety shoes, helmet, safety glasses).
- Failure to follow these instructions can result in injury or equipment damage.**

RISQUE DE COUPURE

- Stockez les produits dans une zone dédiée et balisée.
 - Utilisez des équipements individuels de protection lors de la manipulation et de l'installation des produits (gants, veste à manches longues, pantalon, chaussures de sécurité, casque, lunettes de sécurité).
- Le non-respect de ces instructions peut provoquer des blessures ou des dommages matériels.**



RIESGO DE CORTES

- Almacene los productos en áreas específicas y señalizadas para ello.
 - Utilice un equipo de protección personal cuando manipule e instale los productos (guantes, chaqueta de manga larga, pantalones, zapatos de seguridad, casco y gafas de seguridad).
- Si no se siguen estas instrucciones pueden producirse lesiones personales o daños en el equipo.**

GEFÄHRDUNG DURCH SCHNEIDEN

- Lagern Sie die Produkte im dafür vorgesehenen, gekennzeichneten Bereich.
 - Tragen Sie Schutzkleidung bei der Handhabung und Installation der Produkte (Handschuhe, Jacke mit langen Ärmeln, Hosen, Sicherheitsschuhe, Helm, Schutzbrille).
- Die Nichtbeachtung dieser Anweisungen kann Verletzungen oder Sachschäden zur Folge haben.**



RISCHIO DI TAGLIO

- Conservare i prodotti in un'area dedicata e contrassegnata.
 - Indossare protezioni individuali adeguate per la manipolazione e l'installazione dei prodotti (guanti, giacche a manica lunga, pantaloni, calzature antinfortunistiche, elmetto, occhiali protettivi).
- Il mancato rispetto di queste istruzioni può provocare infortuni o danni alle apparecchiature.**

RISCO DE CORTE

- Armezen os produtos numa área dedicada e assinalada.
 - Use equipamento de protecção pessoal quando manusear e instalar os produtos (luvas, casaco de mangas compridas, calças, calçado de segurança, capacete, óculos de protecção).
- A não observância destas instruções pode provocar ferimentos pessoais, ou danos no equipamento.**



割伤危险

- 请在标明的专门区域存储本产品。
 - 搬运和安装产品时请穿戴个人防护装备（手套、长袖夹克、长裤、安全鞋、头盔、护目镜）。
- 不遵循上述说明可能导致人身伤害或设备损坏。**

РИСК ПОРЕЗОВ

- Храните изделия в специальном месте с маркировкой.
 - Надевайте средства персональной защиты при погрузке-разгрузке и установке изделий (перчатки, куртку с длинными рукавами, брюки, защитную обувь, каску, защитные очки).
- Несоблюдение этих инструкций может привести к травме или повреждению оборудования.**



<p>The product's manufacture date is coded as YYWW, where:</p> <ul style="list-style-type: none"> ■ YY: year of manufacture ■ WW: week of manufacture <p>Eg: 1545 = means the product manufactured on week 45 2015.</p>	<p>La date de fabrication du produit est codée sous la forme YYWW, où:</p> <ul style="list-style-type: none"> ■ YY: année de fabrication ■ WW: semaine de fabrication <p>Ex: 1545 = means the product manufactured on week 45 2015.</p>
<p>La fecha fabricación del producto está codificada como YYWW, donde:</p> <ul style="list-style-type: none"> ■ YY: año de fabricación ■ WW: semana de fabricación <p>Ej: 1545 = means the product manufactured on week 45 2015.</p>	<p>Das Herstellungsdatum des Produkts weist folgendes Format auf: YYWW. Hierbei gilt Folgendes:</p> <ul style="list-style-type: none"> ■ YY: Herstellungsjahr ■ WW: Herstellungswoche <p>Z. B.: 1545 = means the product manufactured on week 45 2015.</p>
<p>La data di costruzione del prodotto è codificata come segue YYWW, dove:</p> <ul style="list-style-type: none"> ■ YY: anno di fabbricazione ■ WW: settimana di fabbricazione <p>Ad es.: 1545 = means the product manufactured on week 45 2015.</p>	<p>A data de fabrico do produto está codificada como YYWW, sendo que:</p> <ul style="list-style-type: none"> ■ YY: ano de fabrico ■ WW: semana de fabrico <p>Ex: 1545 = means the product manufactured on week 45 2015.</p>
<p>产品制造日期编码为 YYWW，其中：</p> <ul style="list-style-type: none"> ■ YY: 制造年份 ■ WW: 第几周制造 <p>例如：1545 = means the product manufactured on week 45 2015.</p>	<p>Дата производства продукта указана в виде кода YYWW, где:</p> <ul style="list-style-type: none"> ■ YY: год производства; ■ WW: неделя производства <p>Пример: 1545 = means the product manufactured on week 45 2015.</p>

KSA80EZ5 - 250A/400A/630A/800A/1000A

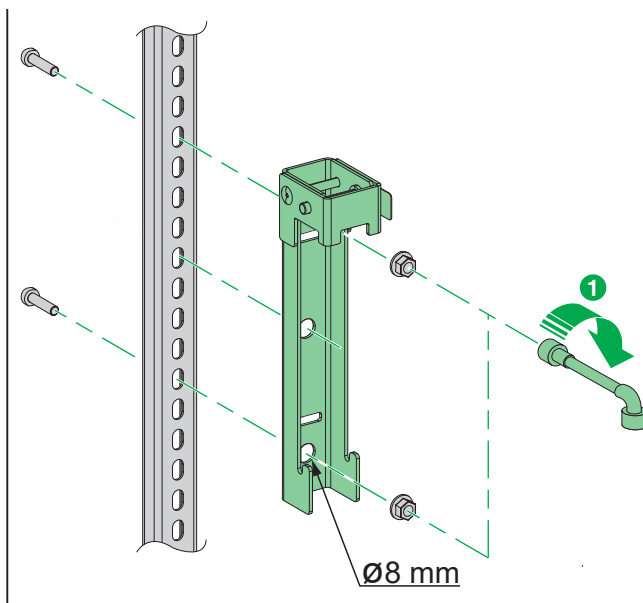
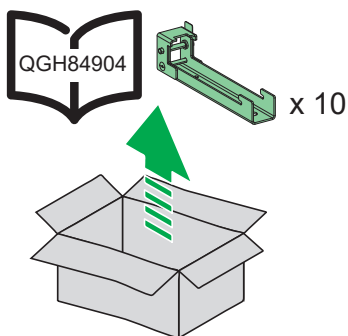

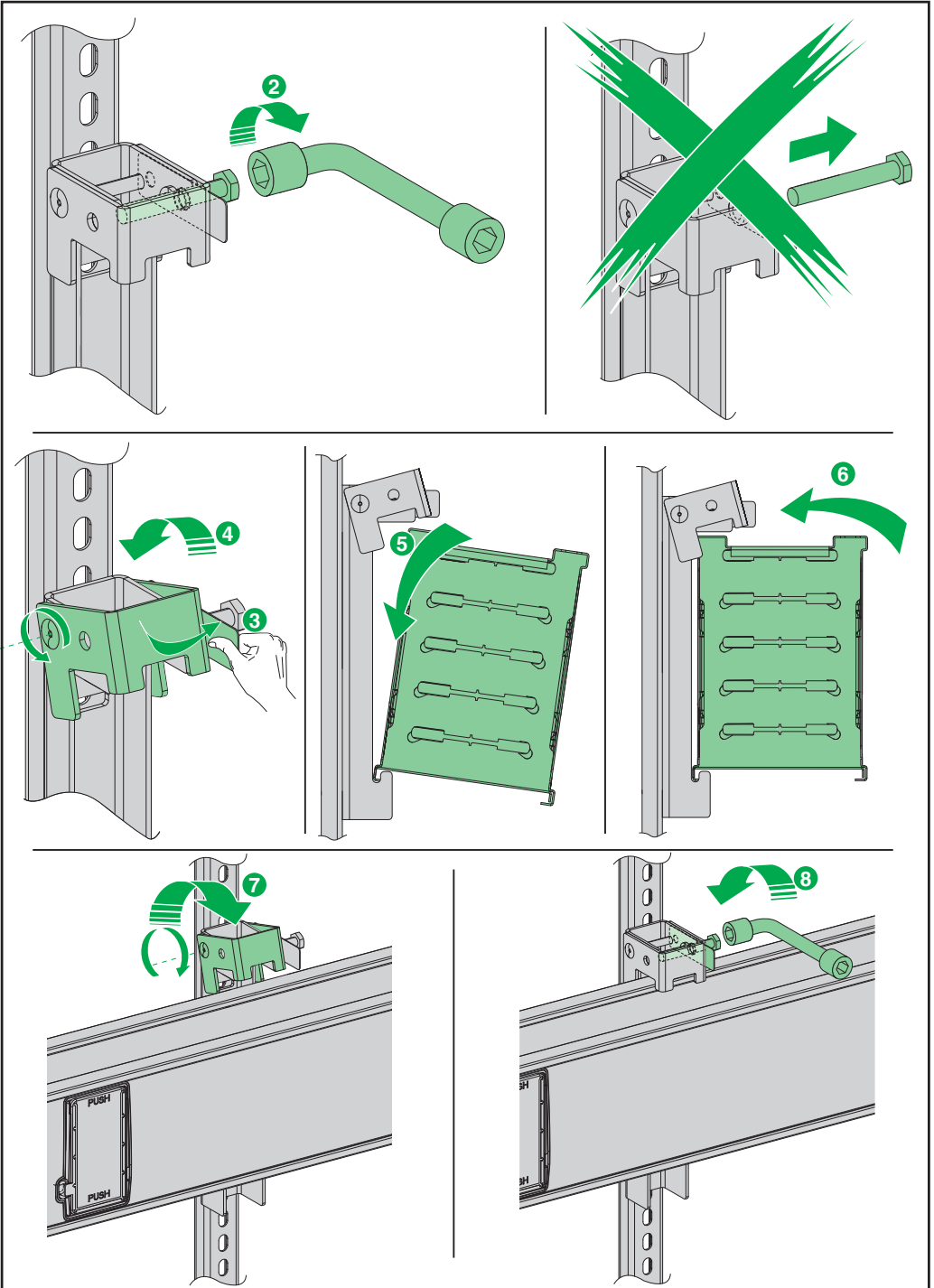

KSA80EZ53

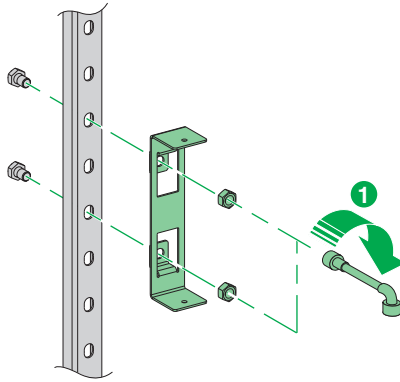

KSA80EZ53 - 250A/400A

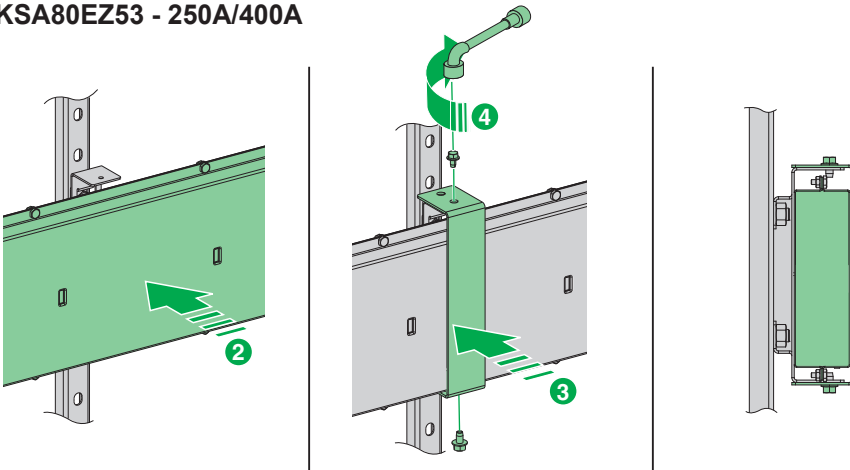

KSA80EZ53 - 630A/800A/1000A

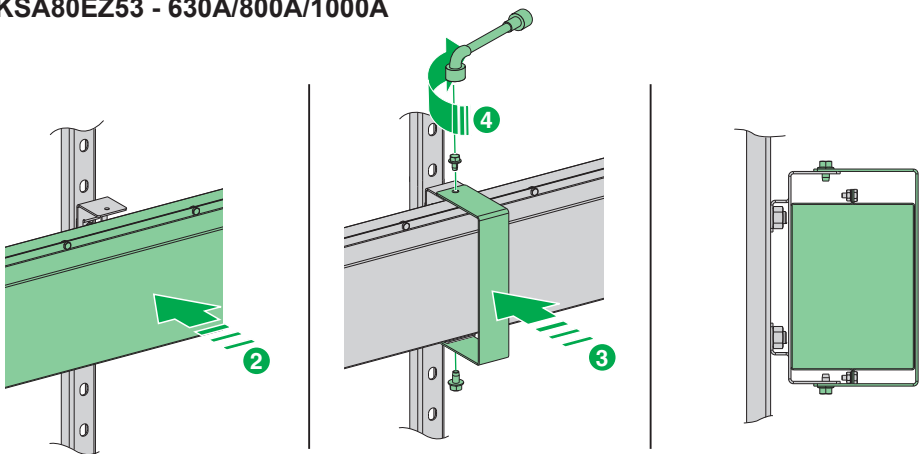

KSB●●●ZF1

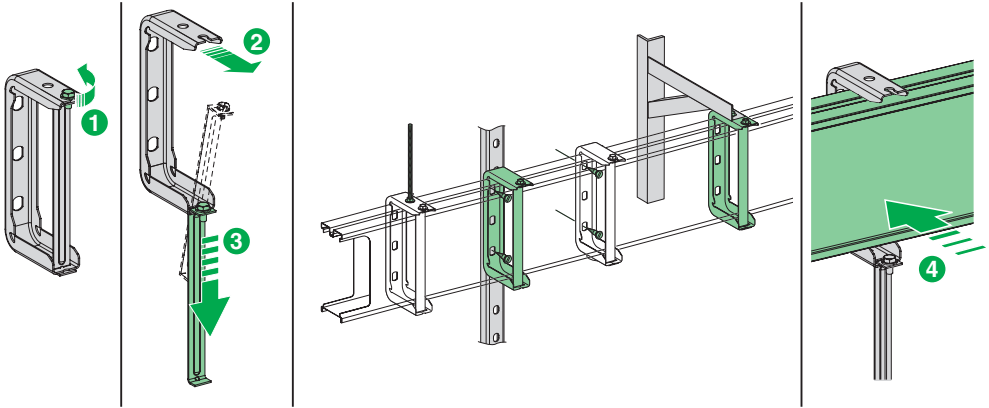

KSB400ZF1 - 250A/400A

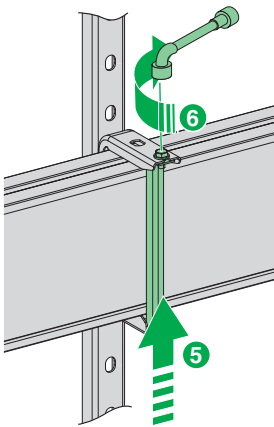

KSA250ED●●●●
KSA400ED●●●●

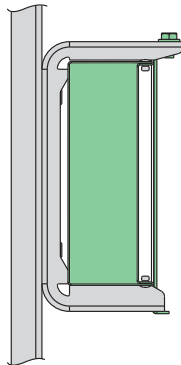

KSA●●●DL●
KSA●●●●AF

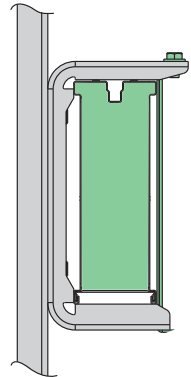

KSB1000ZF1 - 630A/800A/1000A

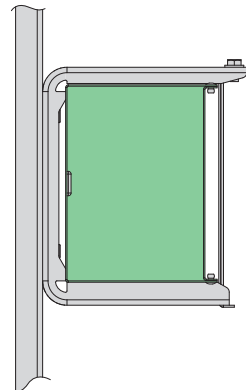
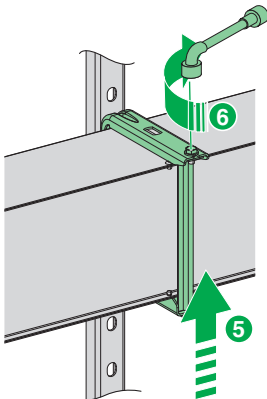

KSB1000ZF1 - 1000A

KSA●●●●ED●●●●●

KSC●●●●ED●●●●●

