

THIS COPY IS PROVIDED ON A RESTRICTED BASIS AND IS NOT TO BE USED IN ANY WAY DETRIMENTAL TO THE INTERESTS OF PANDUIT CORP.

PANDUIT P/N	WEIGHT
WMPVHC45E	23.0 LBS/EACH 10.43 Kg/EACH

NOTES:

- VISIT OUR ON-LINE CATALOG AT [WWW.PANDUIT.COM](http://WWW.PANDUIT.COM) FOR A CURRENT LIST OF PRODUCTS APPLICABLE FOR USE WITH THIS PART.
- COMPONENTS:  
2- 22.5RU CABLE MANAGEMENT SECTIONS  
4- 41.5" DUAL HINGE COVERS  
4- MOUNTING BRACKETS  
8- #12-24 X 1/2" SCREWS
- DIMENSIONS IN PARENTHESES ARE METRIC.

MAX STORAGE TEMPERATURE 65°C (149°F)  
MAX OPERATING TEMPERATURE 60°C (140°F)

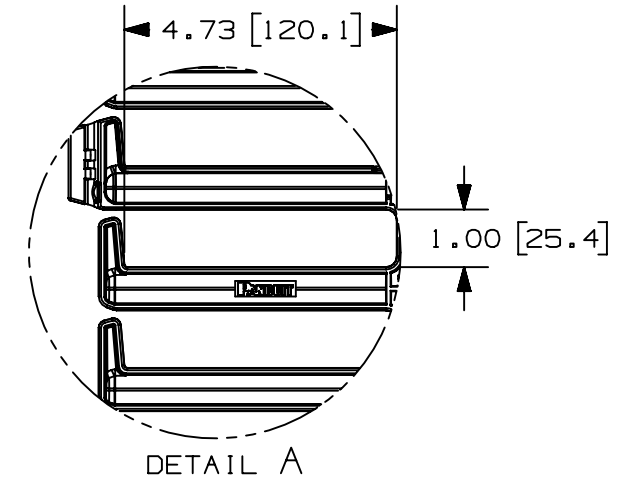
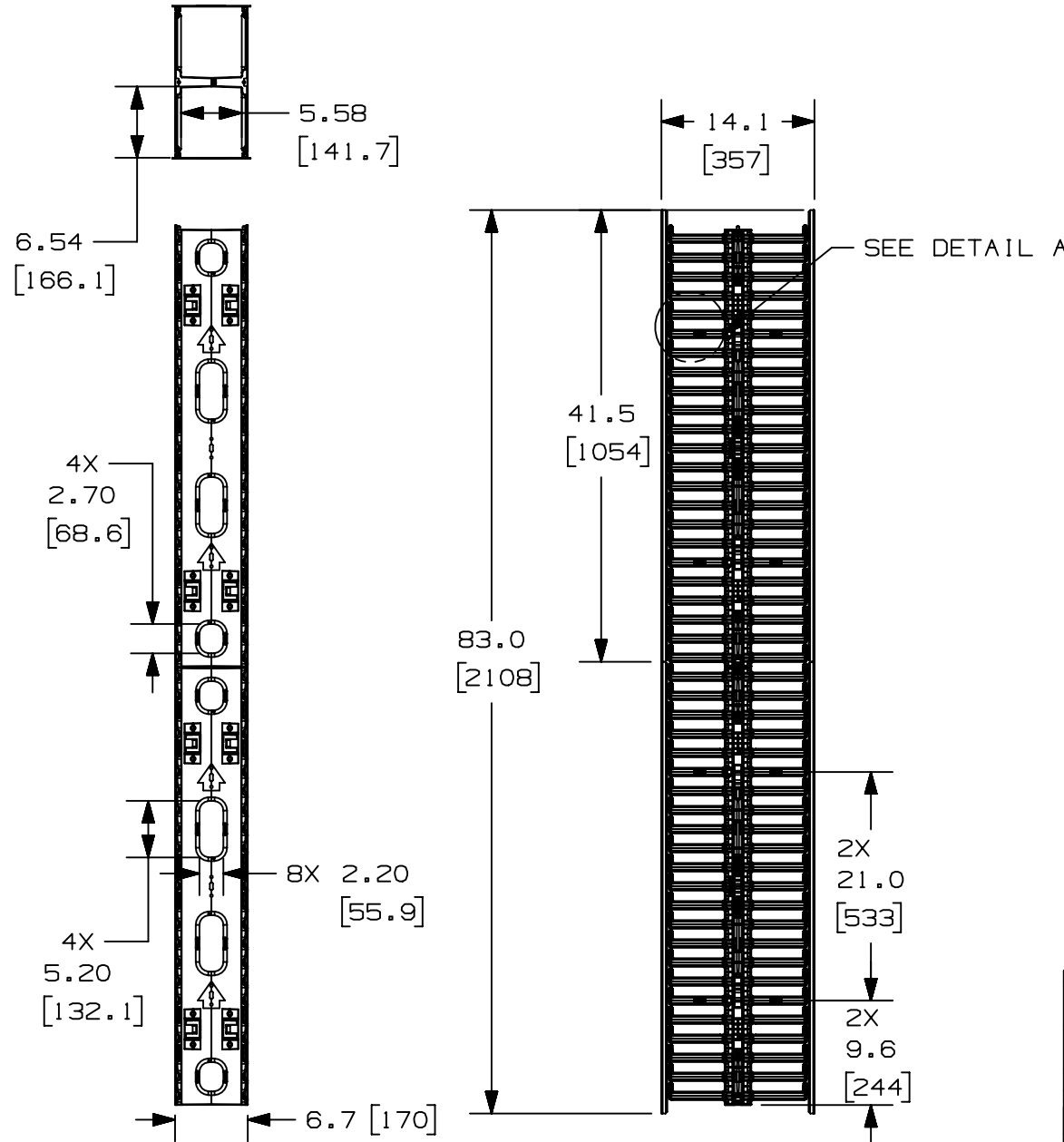

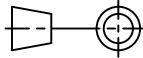
TITLE		CUSTOMER DRAWING	
<b>6" WIDE VERTICAL CABLE MANAGER WMPVHC45E</b>			
ITEM REVISION NAME		V10225AG/06	
DATASET FILE NAME		V10225AG_DC/06B	
 THIRD ANGLE PROJECTION		<b>PANDUIT</b>	
MATERIAL		DRAWING NUMBER	
CABLE MANAGER- ABS COVER- PVC		10225-25	
DRAWN BY	DATE	CHK	SCALE
JDWE	3-15-05	TCK	NONE
SHEET 1 OF 2			SIZE
SHEET 1 OF 2			A

A-SIZE CUSTOMER

REV	DATE	BY	CHK	APR	DESCRIPTION	ECN
06B	5-7-20	JBO	JCO	JEFK	ADDED TEMPERATURE NOTE	M09000LT

THIS COPY IS PROVIDED ON A RESTRICTED BASIS AND IS NOT TO BE USED IN ANY WAY DETRIMENTAL TO THE INTERESTS OF PANDUIT CORP.

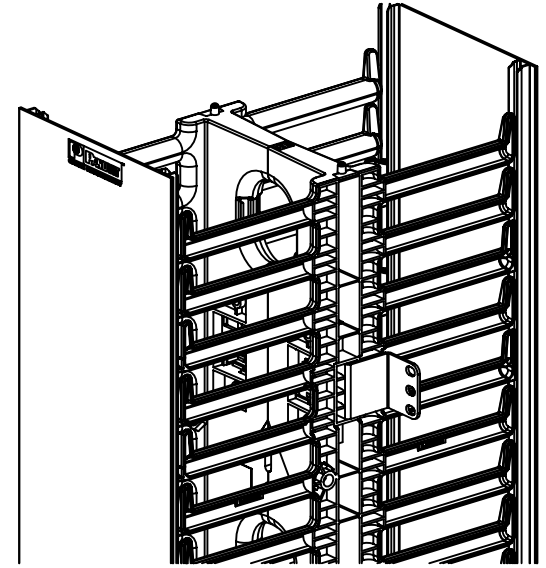
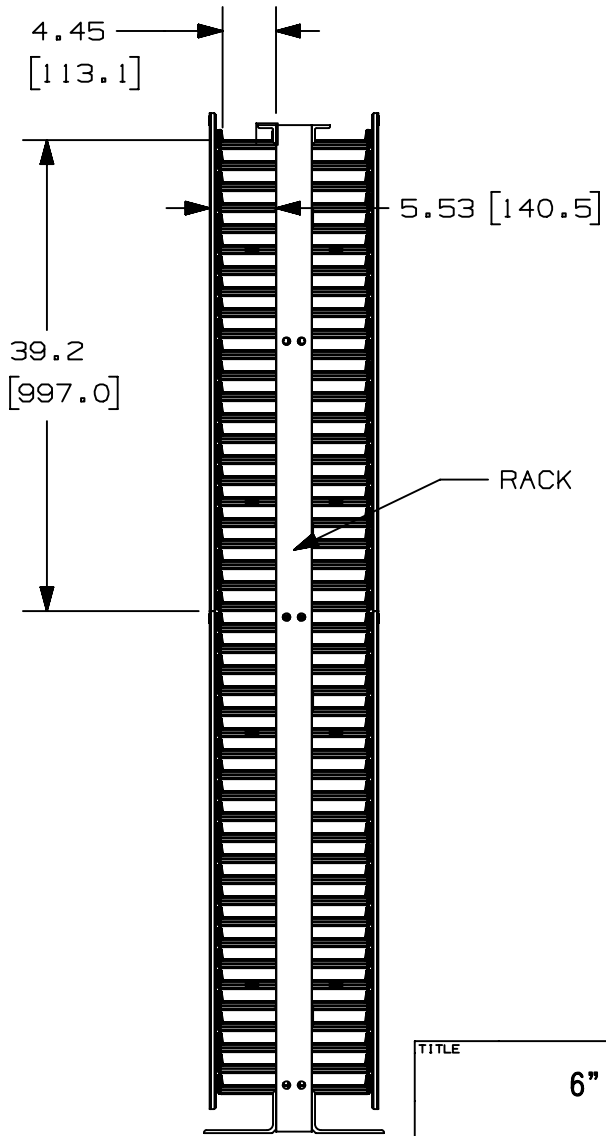
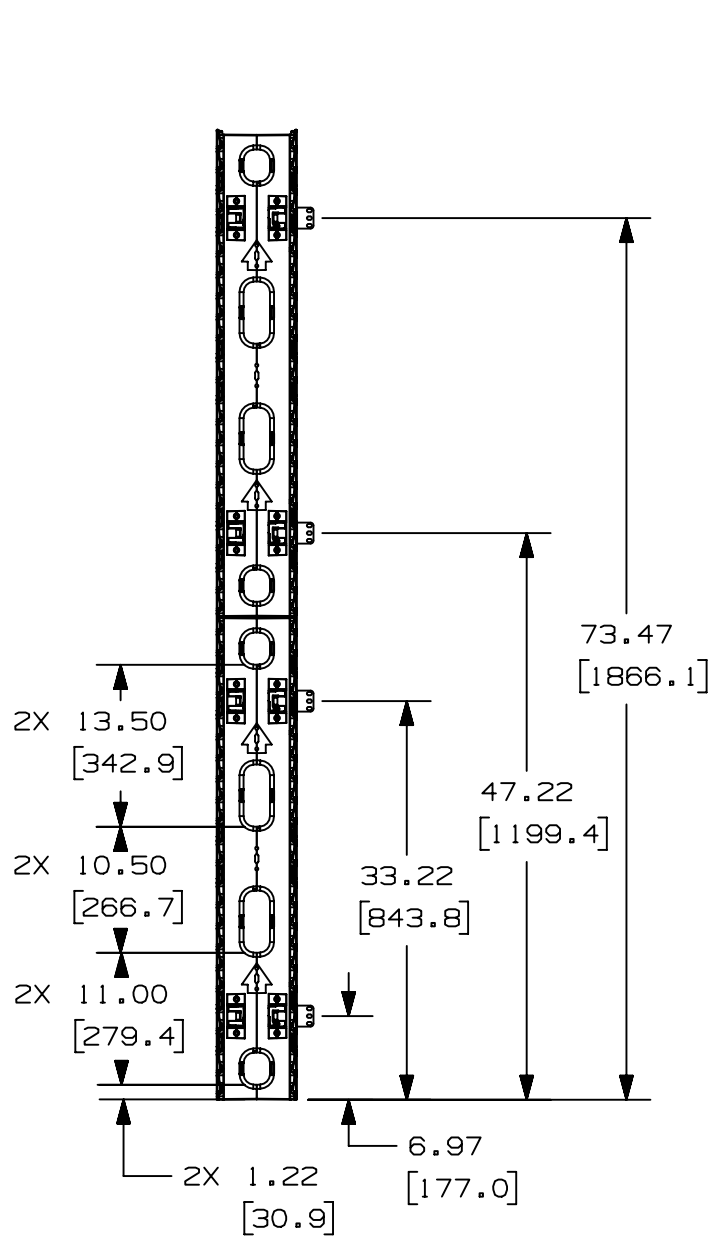

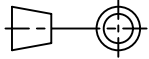
TITLE		6" WIDE VERTICAL CABLE MANAGER WMPVHC45E		
ITEM REVISION NAME		CUSTOMER DRAWING		
DATASET FILE NAME		V10225AG/06		
MATERIAL		CABLE MANAGER- ABS COVER- PVC		
DRAWING NUMBER		10225-25		
THIRD ANGLE PROJECTION				
REV	DATE	BY	CHK	APR
06B	5-7-20	JBO	JCO	JEFK
REFER TO SHEET 1 FOR REVISION CONTROL				ECN
				M09000LT
REV	DATE	BY	CHK	SCALE
JDWE	3-15-05	TCK	NONE	
SHEET 2 OF 2				SIZE
				A

2

1

2

1

A-SIZE CUSTOMER