

GO series microphones - Lavalier, headband or handheld UHF systems

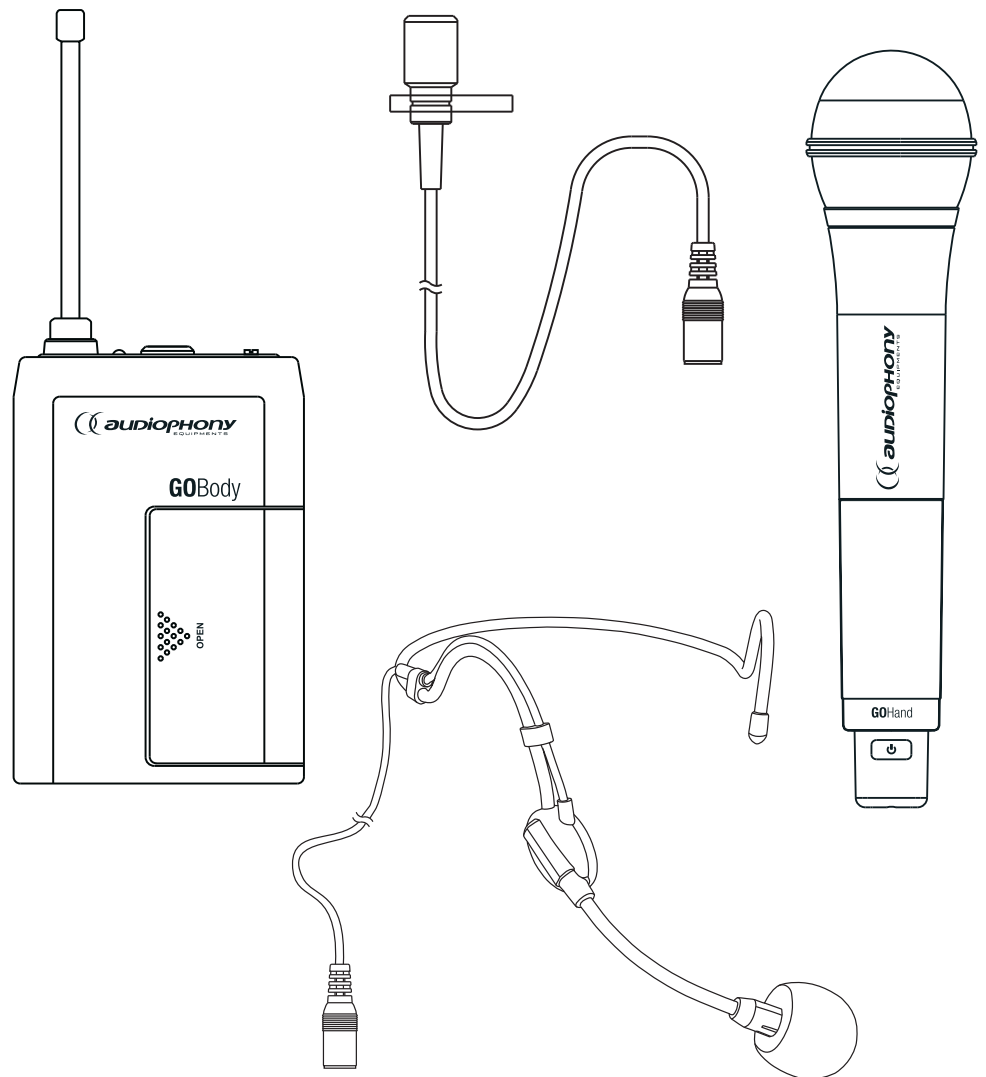
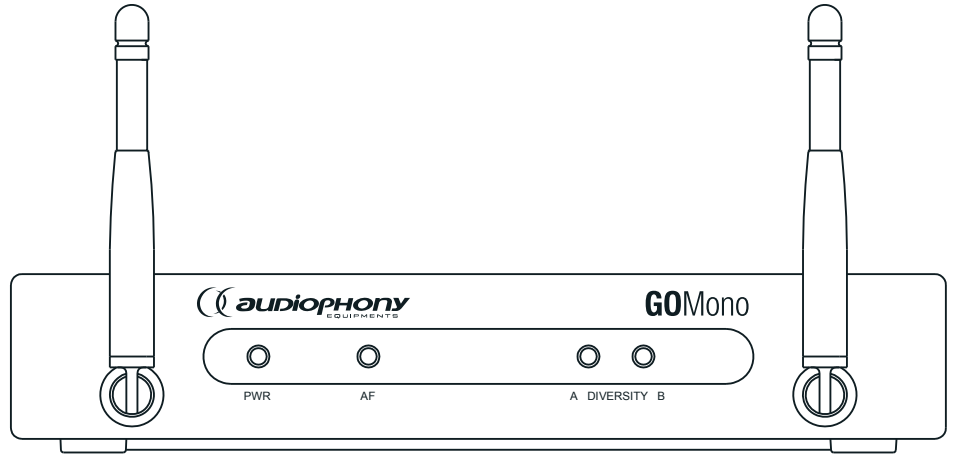
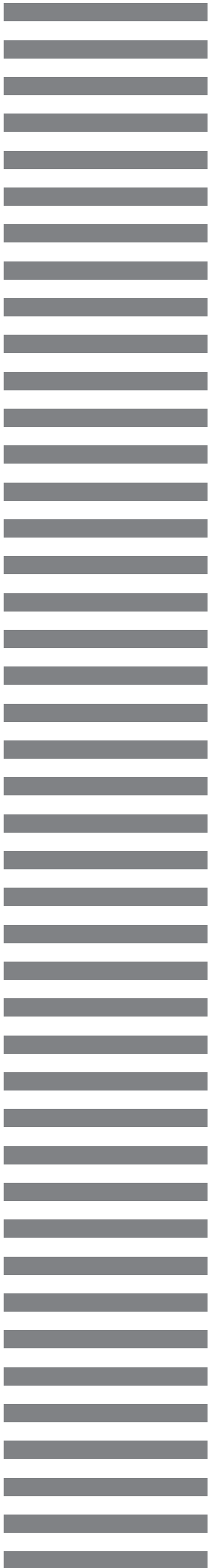

USER GUIDE

1 - Safety information

Important safety information



This unit is intended for indoor use only. Do not use it in a wet, or extremely cold/hot locations. Failure to follow these safety instructions could result in fire, electric shock, injury, or damage to this product or other property.



Any maintenance procedure must be performed by a CONTEST authorised technical service. Basic cleaning operations must thoroughly follow our safety instructions.



This product contains non-isolated electrical components. Do not undertake any maintenance operation when it is switched on as it may result in electric shock.

Symbols used



This symbol signals an important safety precaution.



The WARNING symbol signals a risk to the user's physical integrity. The product may also be damaged.



The CAUTION symbol signals a risk of product deterioration.

Instructions and recommendations

1 - Please read carefully :

We strongly recommend to read carefully and understand the safety instructions before attempting to operate this unit.

2 - Please keep this manual :

We strongly recommend to keep this manual with the unit for future reference.

3 - Operate carefully this product :

We strongly recommend to take into consideration every safety instruction.

4 - Follow the instructions:

Please carefully follow each safety instruction to avoid any physical harm or property damage.

5 - Avoid water and wet locations :

Do not use this product in rain, or near washbasins or other wet locations.

6 - Installation :

We strongly encourage you to only use a fixation system or support recommended by the manufacturer or supplied with this product. Carefully follow the installation instructions and use the adequate tools.

Always ensure this unit is firmly fixed to avoid vibration and slipping while operating as it may result in physical injury.

7 - Ceiling or wall installation :

Please contact your local dealer before attempting any ceiling or wall installation.

8 - Ventilation :

The cooling vents ensure a safe use of this product, and avoid any overheating risk. Do not obstruct or cover these vents as it may result in overheating and potential physical injury or product damage. This product should never be operated in a closed non-ventilated area such as a flight case or a rack, unless cooling vents are provided for the purpose .

9 - Heat exposure :

Sustained contact or proximity with warm surfaces may cause overheating and product damages. Please keep this product away from any heat source such as a heaters, amplifiers, hot plates, etc...

CAUTION

RISK OF ELECTRIC SHOCK

DO NOT OPEN

WARNING : This unit contains no user-serviceable parts. Do not open the housing or attempt any maintenance by yourself. In the unlikely even your unit may require service, please contact your nearest dealer.
In order to avoid any electrical malfunction, please do not use any multi-socket, power cord extension or connecting system without making sure they are perfectly isolated and present no defect.

Sound levels

Our audio solutions deliver important sound pressure levels (SPL) that can be harmful to human health when exposed during long periods. Please do not stay in close proximity of operating speakers.

Recycling your device

- As HITMUSIC is really involved in the environmental cause, we only commercialise clean, ROHS compliant products.
- When this product reaches its end of life, take it to a collection point designated by local authorities. The separate collection and recycling of your product at the time of disposal will help conserve natural resources and ensure that it is recycled in a manner that protects human health and the environment.

10 - Electric power supply :

This product can only be operated according to a very specific voltage. These information are specified on the label located at the rear of the product.

11 - Power cords protection:

Power-supply cords should be routed so that they are not likely to be walked on or pinched by items placed upon or against them, paying particular attention to cords at lugs, convenience receptacles and the point where they exit from the fixture.

12 - Cleaning precautions :

Unplug the product before attempting any cleaning operation. This product should be cleaned only with accessories recommended by the manufacturer. Use a damp cloth to clean the surface. Do not wash this product.

13 - Long periods of non use :

Disconnect the unit's main power during long periods of non use.

14 - Liquids or objects penetration :

Do not let any object penetrate this product as it may result in electric shock or fire. Never spill any liquid on this product as it may infiltrate the electronic components and result in electric shock or fire.

15 - This product should be serviced when :

Please contact the qualified service personnel if :

- The power cord or the plug has been damaged.
- Objects have fallen or liquid has been spilled into the appliance.
- The appliance has been exposed to rain or water.
- The product does not appear to operate normally.
- The product has been damaged.

16 - Inspection/maintenance :

Please do not attempt any inspection or maintenance by yourself. Refer all servicing to qualified personnel.

17 - Operating environment :

Ambient temperature and humidity: +5 - +35°C, relative humidity must be less than 85% (when cooling vents are not obstructed).

Do not operate this product in a non-ventilated, very humid or warm place.

2 - Presentation of the GO series

UHF system with 16 frequencies and up to 4 microphones simultaneously, depending on the configuration and the conditions of your performance.

This user guide will provide useful information and details about the whole GO series and its components.

2.1 - GoMono code H9988 (F8 series) et H11029 (F5 series)

Receiver box

- Carrier frequency:
 - GO F8 series: UHF 823~832MHz/863~865MHz
 - GO F5 series: UHF 514~542MHz
- 16 preset UHF frequencies to easily select a frequency and use several systems simultaneously.
- The diversity technology and adjustable squelch guarantee high-quality transmissions, without parasitic noises.
- The AF indicator indicates the audio signal status.
- The output level is adjusted to avoid any signal saturation.
- The antennas are located at the front so you can easily put it into racks.
- The outgoing signal is available with the balanced XLR chassis or the unbalanced Jack 6.35 chassis to fit your needs.
- Compliant with the FCC, CE and RoHS norms.

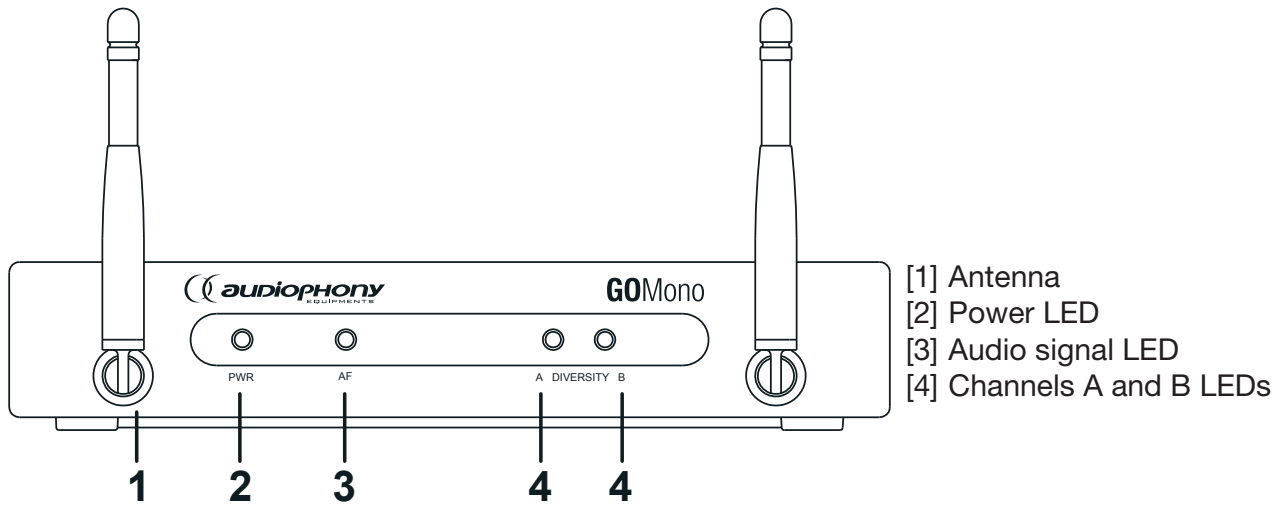

- [1] Antenna
- [2] Power LED
- [3] Audio signal LED
- [4] Channels A and B LEDs

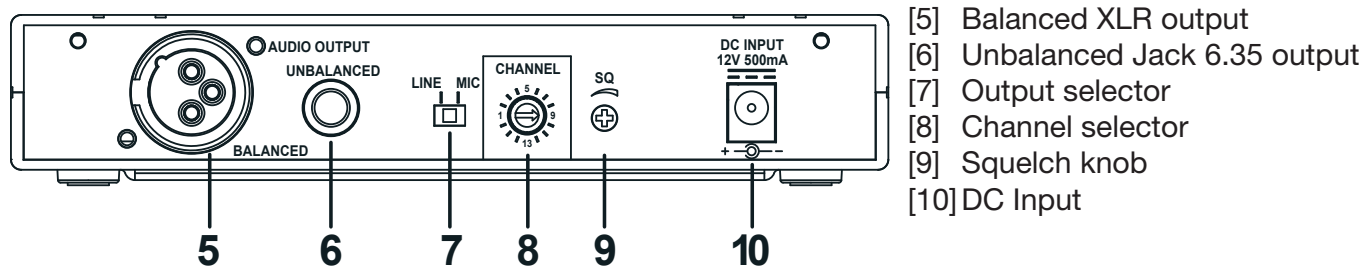

- [5] Balanced XLR output
- [6] Unbalanced Jack 6.35 output
- [7] Output selector
- [8] Channel selector
- [9] Squelch knob
- [10] DC Input

2.2 - GOHand code H9989 (F8 series) and H11030 (F5 series)

Handheld microphone

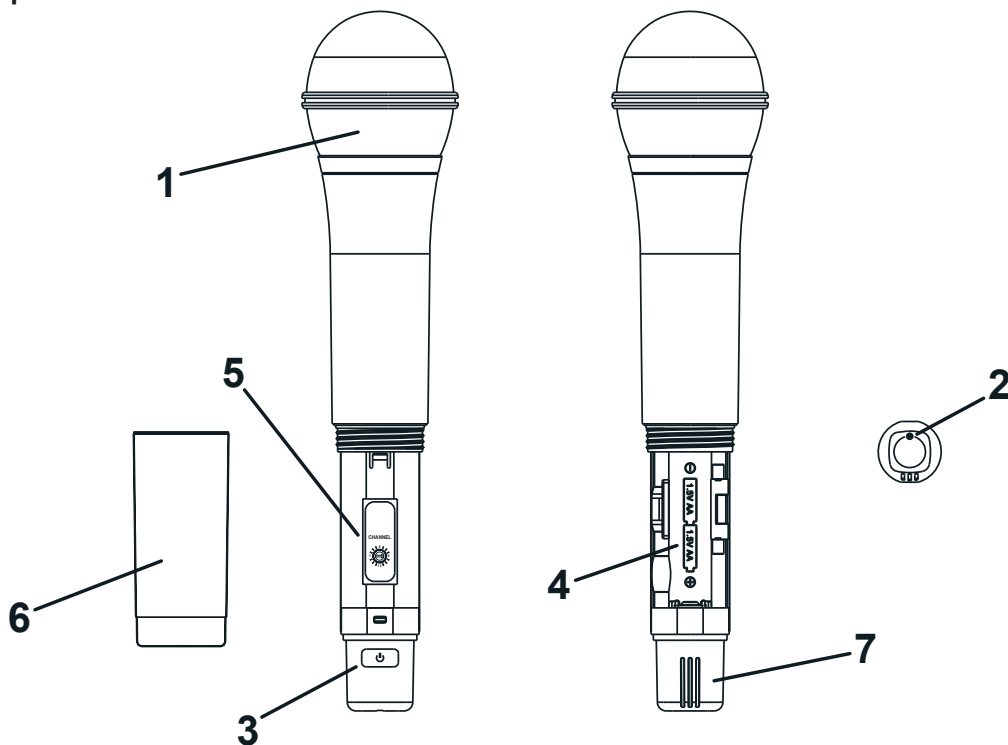

- [1] Protection grille.
- [2] Battery level LED indicator. This LED lights up when the microphone is activated, flashes when the battery level is too low, and do not light up if the batteries are empty or not properly installed.
- [3] ON/OFF button: Press and hold for 2 seconds to activate/deactivate the microphone.
- [4] Battery compartment.
- [5] Channel selector: Allows you to choose the transmission channel, depending on the channel used by the receiver.
- [6] Battery compartment panel.
- [7] Helical antenna compartment.

Note : Turning the microphone off when the receiver is still activated might create audible noise interference.

2.3 - GOBody code H9990 (F8 series) and H11031 (F5 series)

Bodypack transmitter with mini-XLR input

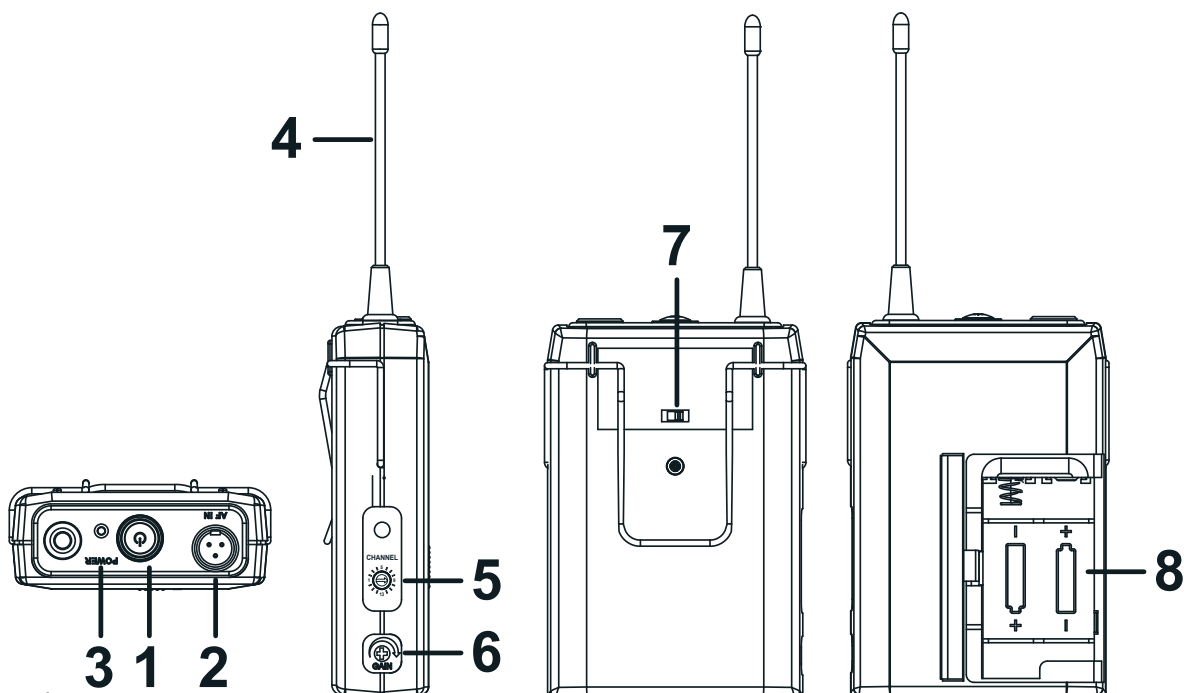

- [1] ON/OFF button: Press and hold for 2 seconds to activate/deactivate the transmitter.
- [2] Male mini-XLR socket
- [3] Battery level LED indicator. This LED lights up when the microphone is activated, flashes when the battery level is too low, and do not light up if the batteries are empty or not properly installed
- [4] Antenna
- [5] Channel selector. Allows you to choose the transmission channel, depending on the channel used by the receiver.

- [6] Gain control knob.
- [7] Output selector. Allows you to connect either an electret microphone or a line level device (such as CD players).
- [8] Battery compartment.

2.4 - GOLava code H9992

Lavalier microphone with condenser cell

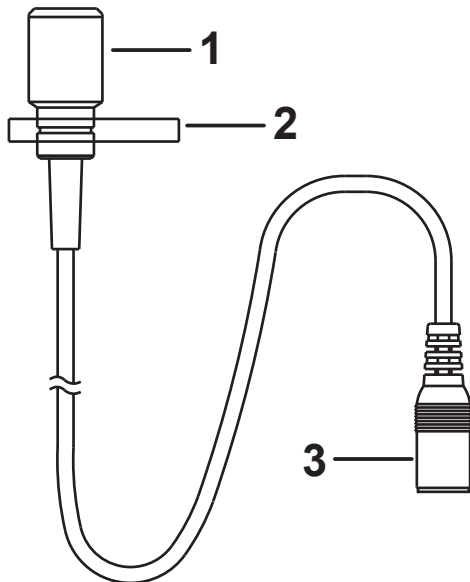

- [1] Condenser microphone
- [2] Tie clip
- [3] Female mini-XLR socket

2.5 - GOHead code H9991

Headband condenser microphone

- [1] Adjustable metal headband
- [2] Condenser microphone with windshield
- [3] Female mini-XLR socket

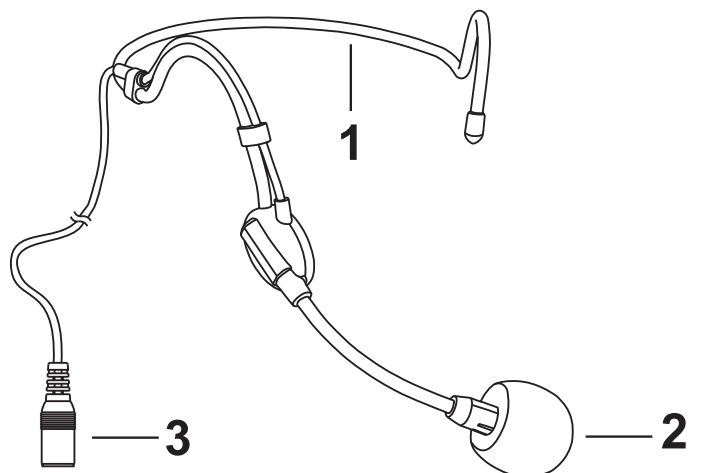

3 - Installation

3.1 - Connecting the receiver

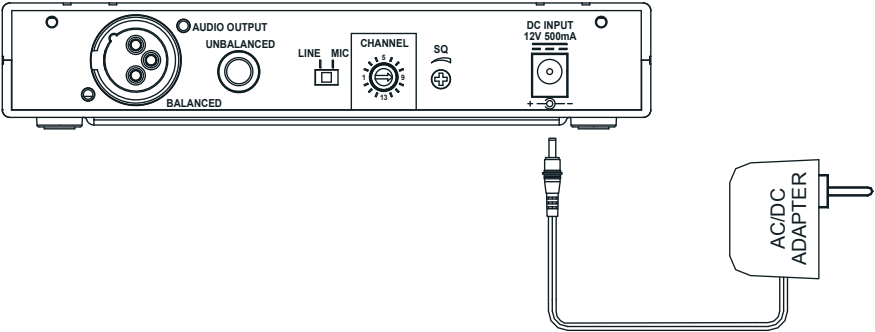
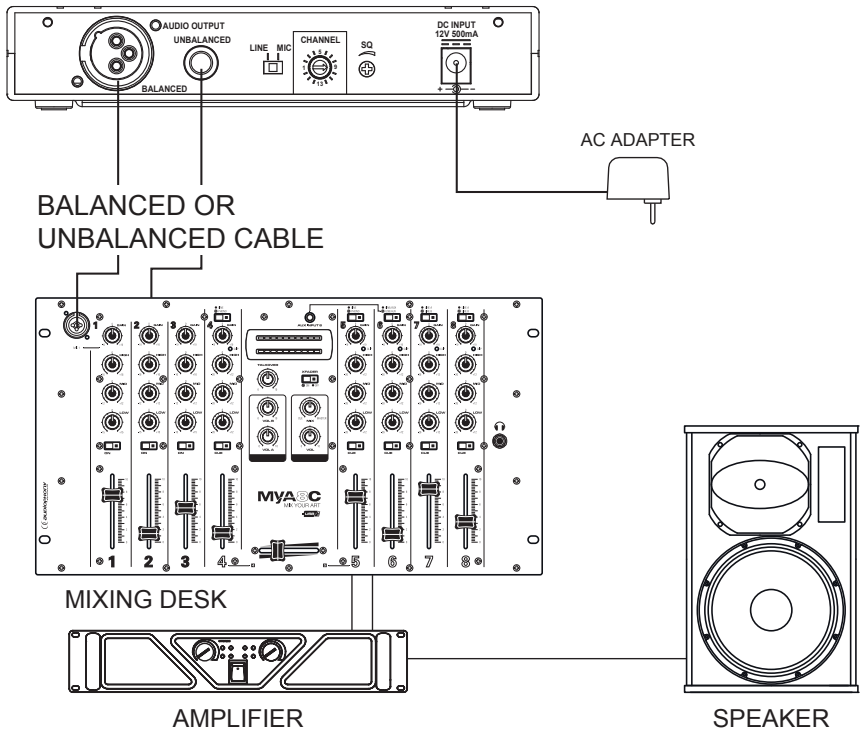
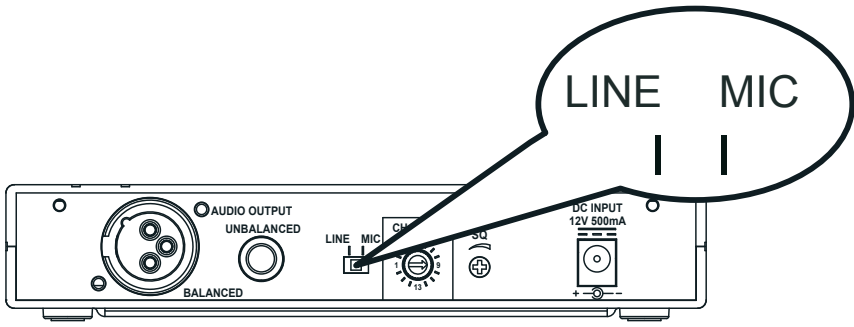
	<ul style="list-style-type: none"> - Connect the supplied AC adapter to an electrical outlet, and to the DC 12V socket located at the rear of the GOMono receiver.
	<ul style="list-style-type: none"> - Connect the audio output to your mixing desk with either a balanced XLR cable or unbalanced Jack 6.35. - Do not use both the unbalanced and balanced outputs simultaneously as it might cause signal losses and increases parasitic noises. - In order to preserve a good sound quality and prevent distortions, you can adjust the volume by following the instructions below: - If you are using a microphone input of your mixing desk or amplifier, turn the volume to half power (approximately), the balanced and unbalanced outputs level will then be close to 77 mV. - If you are using a line level input of your mixing desk or amplifier, turn the volume to 3/4 of the maximum power, the unbalanced and balanced outputs will then be close to 770 mV.
	<ul style="list-style-type: none"> - Adjust the output level to the input level used by the mixing desk. - MIC level: - 20dBm - LINE level: 0 dB

3.2 - Commissioning GOBody et GOHand transmitter

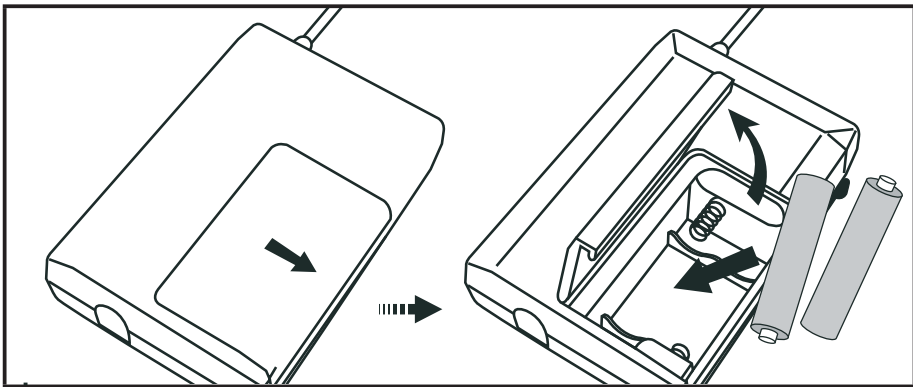
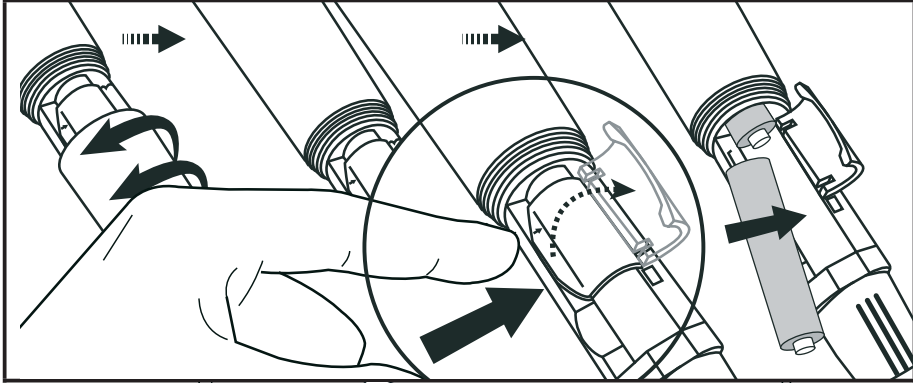
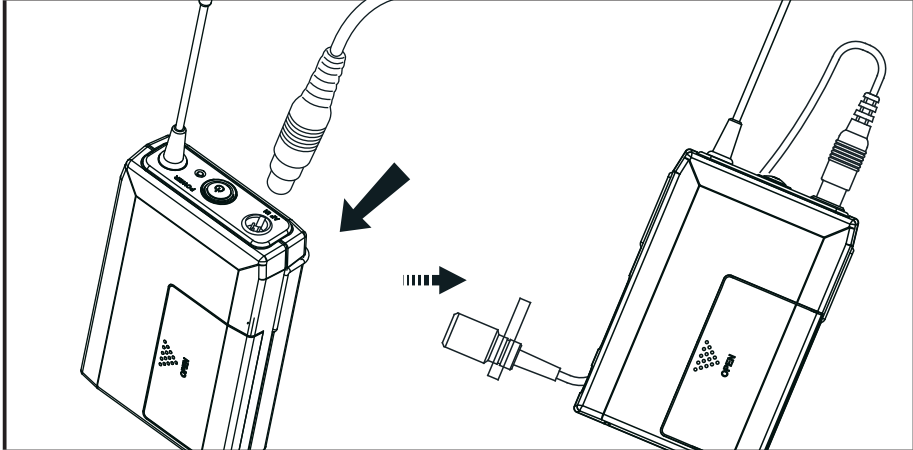
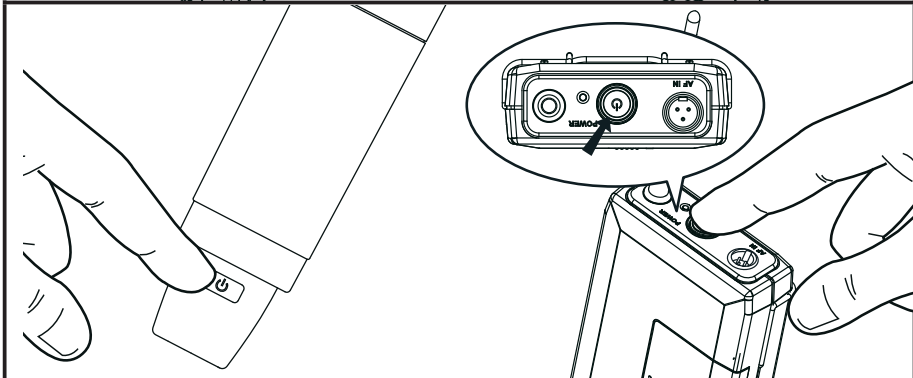
	<p>- Open the battery compartment and insert two LR6 or AA batteries. Please respect the polarity as described opposite.</p>
	<p>- Unscrew the battery compartment panel and insert two LR6 or AA batteries. Please respect the polarity as described opposite.</p>
	<p>- Connect the mini XLR plug of your microphone to the input of the transmitter box.</p>
	<p>- Press and hold the Power button for 2 seconds to activate the device.</p>

Note : During long periods of non-use, please turn off the microphone and transmitter and remove the batteries.

3.3 - Battery charge level indicator

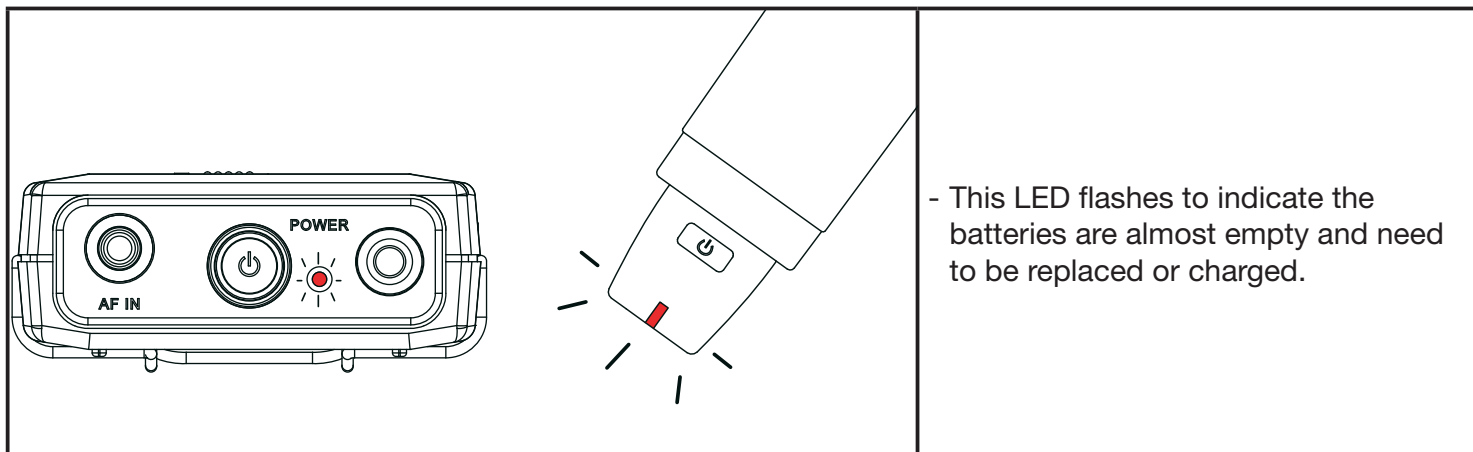

- This LED flashes to indicate the batteries are almost empty and need to be replaced or charged.

3.4 - Using the output selector

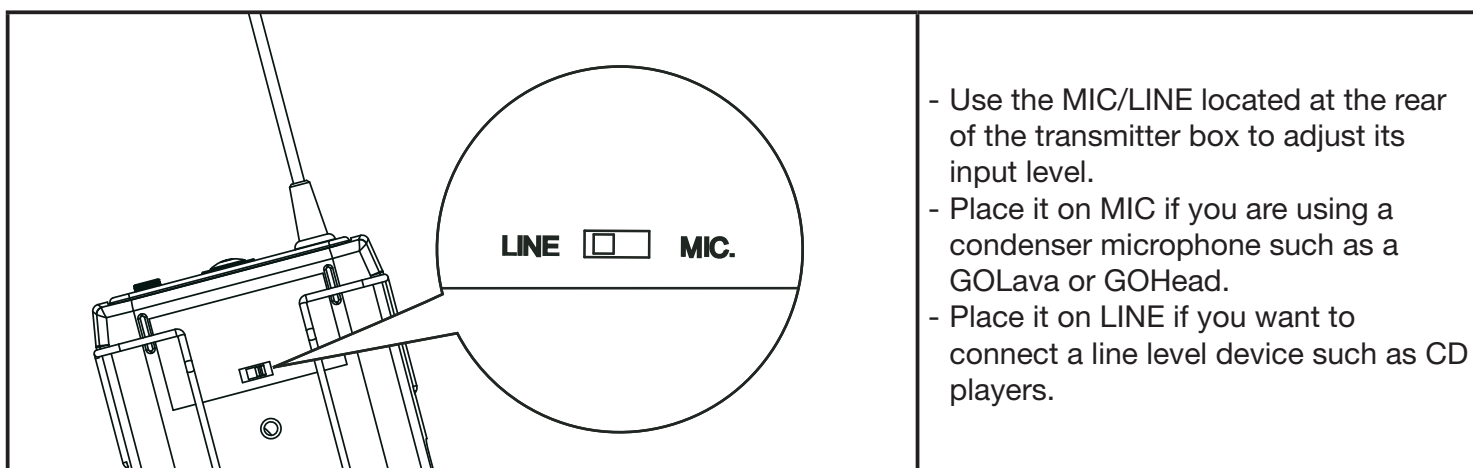

- Use the MIC/LINE located at the rear of the transmitter box to adjust its input level.
- Place it on MIC if you are using a condenser microphone such as a GOLava or GOHead.
- Place it on LINE if you want to connect a line level device such as CD players.

3.5 - Using the 19" coupler (optional: FREE-RACK Code H9374)

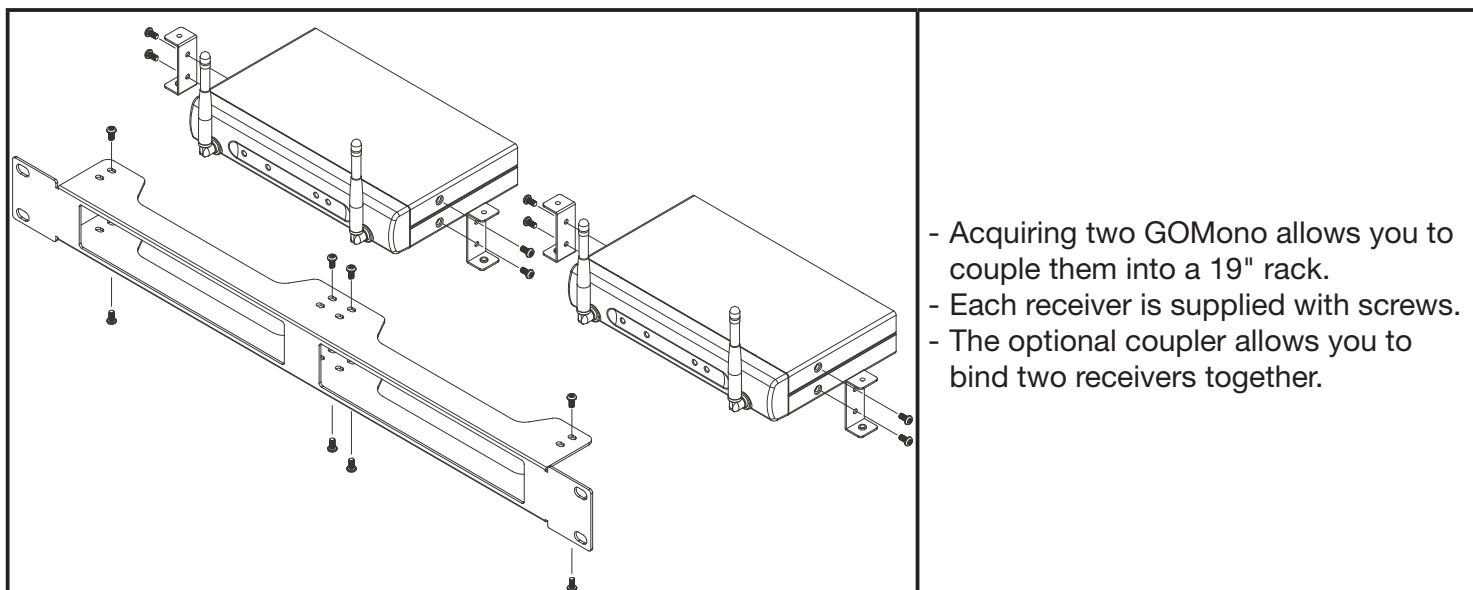

- Acquiring two GOMono allows you to couple them into a 19" rack.
- Each receiver is supplied with screws.
- The optional coupler allows you to bind two receivers together.

3.6 - Configuring channels

Use the faders located on your transmitter and receiver to select the carrier frequency of your UHF system.

Your transmitter and receiver must be set on the same channel.

In order to use several mic simultaneously, choose frequencies as far apart as possible.

For instance for F8 series:

For mic no. 1 on channel 1 (823.175 MHz)

For mic no. 2 on channel 6 (827.375 MHz)

For mic no. 3 on channel 13 (863.275 MHz)

For mic no. 4 on channel 16 (864.725 MHz)

This frequency range allows the use of 4 microphone simultaneously, at full volume, in the best environment possible.

However, the signal reception depends on surrounding disturbances that might impact on the performances.

3.7 - Available frequencies

F5 GO series	
Canal 1	514.000 MHz
Canal 2	515.500 MHz
Canal 3	517.000 MHz
Canal 4	518.750 MHz
Canal 5	520.500 MHz
Canal 6	522,250 MHz
Canal 7	524.000 MHz
Canal 8	525.750 MHz
Canal 9	526,750 MHz
Canal 10	529.000 MHz
Canal 11	531.500 MHz
Canal 12	533.750 MHz
Canal 13	534.750 MHz
Canal 14	537.000 MHz
Canal 15	539.500 MHz
Canal 16	541.750 MHz

F8 GO series	
Canal 1	823.175 MHz
Canal 2	823.875 MHz
Canal 3	824.825 MHz
Canal 4	825.425 MHz
Canal 5	826.225 MHz
Canal 6	827.375 MHz
Canal 7	828.225 MHz
Canal 8	828.725 MHz
Canal 9	829.500 MHz
Canal 10	830.575 MHz
Canal 11	831.375 MHz
Canal 12	831.825 MHz
Canal 13	863.275 MHz
Canal 14	863.675 MHz
Canal 15	864.325 MHz
Canal 16	864.725 MHz

4 - Troubleshooting

No sound:

- Check on the power supply units.
- Check on the frequency channels - It must be the same channel on both the transmitter and receiver.
- Check on the connectors between the receiver and the amplification system.
- Check on the transmitter/receiver distance and Squelch settings.
- Make sure the receiver is not hidden by a metallic surface.
- Check on the batteries.

Poor sound quality or interference:

- Check on the position of the antennas.
- Make sure each transmitter is on a different frequency.
- Make sure interferences are not caused by other devices such as televisions, radios, etc.
- Check on the volume of the receiver.
- Check on the batteries.
- Adjust the input gain of your mixing desk channel.



Watch out for audio feedbacks
Avoid high gain levels on your mixing desk or high volume on your receiver.
Maintain a reasonable distance from the speakers.
The feedback may cause severe damage to your hearing and sound system.



4 - Technical specifications

GOMono receiver

- Carrier frequency: UHF 823~832MHz/863~865 MHz and 514~542MHz
- Housing: Compact
- Oscillator: PLL synthesiser
- Reception: Diversity Mono channel
- Frequency stability: $\pm 0.005\%$
- Reception sensitivity: at 10 μV beyond 80dB S/N ratio
- Minimum rejection rate: 80 dB
- Selectivity : higher than 50 dB
- Modulation: FM
- Dynamic range: >100dB
- Tone Signal: 32.768KHz
- Signal to noise ratio: higher than 94dB, at 20KHz deviation and 60dBuV antenna input level
- Frequency response: 80HZ at 16KHz
- Distortion rate: lower than 1% (@ 1KHz)
- Frequency settings: via faders
- Power supply: DC 12V
- Audio output: Balanced and unbalanced
- Power consumption: 130 mA max.
- Dimensions L x H x D : 170 x 32 x 106 mm

GOHand microphone

- Carrier frequency: UHF : UHF 823~832MHz/863~865 MHz and 514~542MHz
- Maximum output level: 10mW max. (F8 series) / 35mW max. (F5 series)
- Oscillator : PLL synthesiser with 16 selectable channels
- Type: Handheld microphone
- Frequency stability: $\pm 0.005\%$
- Max deviation: $\pm 20\text{KHz}$
- Distortion rate: lower than 1.0% (@ 1KHz)
- Unwanted emissions: lower than 60 dB below the carrier frequency
- Power supply:
 - 3V DC (2 x 1.5V AA batteries)
 - 2.4V DC (2 x 1.2V AA rechargeable batteries)
- Tone Key: 32,768KHz
- Unidirectional condenser microphone
- Consumption : 120mA \pm 10mA
- Dimensions (L x D) : 237 x 58 mm

GOBody transmitter

- Frequency range: UHF 823~832MHz/863~865 MHz and 514~542MHz
- Maximum output level: 10mW max. (F8 series) / 35mW max. (F5 series)
- Oscillator: PLL synthesiser
- Frequency stability: $\pm 0,005\%$
- Maximum deviation: $\pm 20\text{KHz}$
- Unwanted emissions: higher than 60 dB below the carrier frequency
- T.H.D. : $<1\%$ (@1KHz)
- Batteries
 - 3V DC (2 x 1.5V AA batteries)
 - 2.4V DC (2 x 1.2V AA rechargeable batteries)
- Tone Key: 32,768KHz
- Frequency settings: via faders
- Power consumption: 120mA \pm 10mA
- Dimensions: 65 x 100 x 27 mm

GOHead microphone

- Type: Condenser capsule
- Sensitivity: -67 $\pm 3\text{dB}$
- Impedance: 2.2 K Ohms
- Directivity: Cardioid unidirectional
- Frequency response: 100Hz - 16KHz
- Maximum operating voltage: 10V
- Normal voltage range: 1.5V
- Power consumption: 0,5mA max.
- Signal to noise ratio: Higher than 60dB
- Supplied accessory: Windshield
- Connector: Mini XLR

GOLava microphone

- Type: Condenser cell
- Sensitivity: -67 $\pm 3\text{dB}$
- Impedance: 2.2 k Ohms
- Directivity: Cardioid unidirectional
- Frequency response: 100Hz - 16KHz
- Maximum operating voltage: 10V
- Normal voltage range: 1.5V
- Power consumption: 0,5mA max.
- Signal to noise ratio: Higher than 60dB
- Supplied accessories: Windshield and tie-clip
- Connector: Mini XLR

EC DECLARATION OF CONFORMITY

We, **HIT-MUSIC SAS**,

Address: Parc d'Activités CAHORS SUD - 46230 FONTANES - France

Declare under our sole responsibility that the Audiophony UHF wireless transmitter and receiver microphones:

GO-Mono (H9988 et H11029)/ GO-Hand (H9989 et H11030) / GO-Body (H9990 et H11031)

Are in conformity with the Council Directives:

- 2011/65/UE ROHS
- 2014/53/EU RED
- 2014/35/EU LVD
- 2014/30/EU EMC

And are in conformity with the following standards or normative documents :

- EN 300 422-2 V1.2.2 (2008-03)
- EN 301 489-1 V1.8.1 (2008-04)
- EN 301 489-9 V1.4.1 (2007-11)
- EN 60065 :2002+A1 : 2006 + A11 :2008+A2 :2010

Additional information: None

At Cahors, 12th of February, 2020

www.audiophony.com

9 - New UHF frequency plan

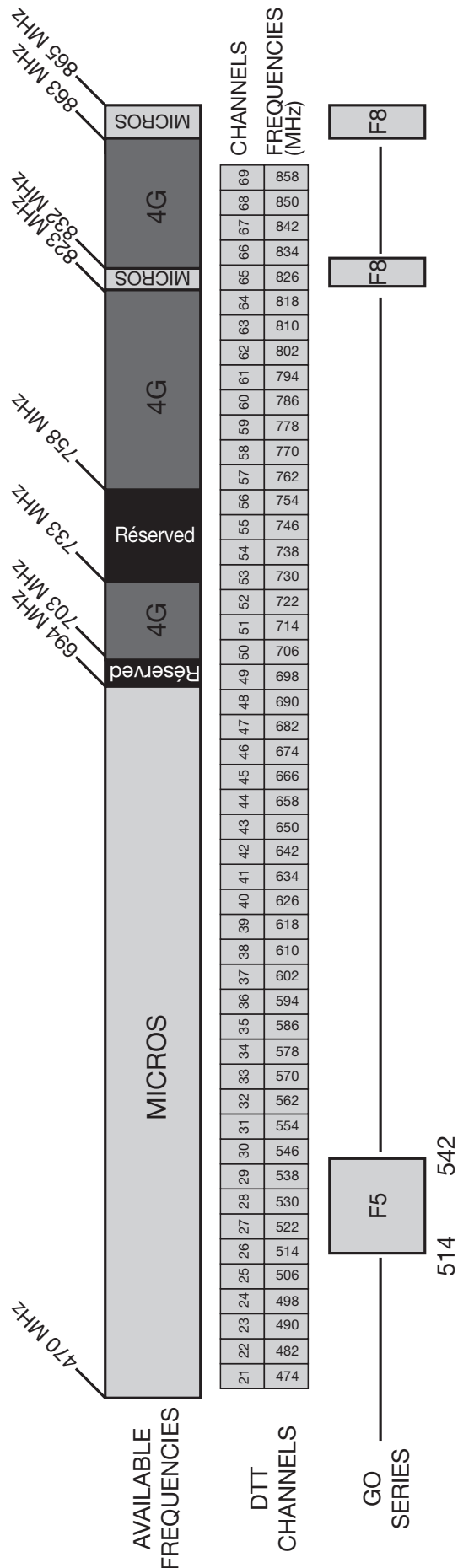

The authorised frequency bands can thus be used "freely" by PMSE equipment, i.e. without the need for prior individual authorisation, but subject to compliance with the technical parameters laid down.

In these circumstances, users of ancillary sound programme design and broadcasting equipment shall not be subject to the payment of fees. However, they must not interfere with other uses of frequencies, and are not protected against interference.

Please check your local services authorised to be sure that you can use the frequencies range of your system.

Because AUDIOPHONY® takes the utmost care in its products to make sure you only get the best possible quality, our products are subjects to modifications without prior notice. That is why technical specifications and the products physical configuration might differ from the illustrations.

Make sure you get the latest news and updates about the AUDIOPHONY® products on www.audiophony.com
AUDIOPHONY® is a trademark of HITMUSIC S.A.S - Zone Cahors sud - 46230 FONTANES - FRANCE