

THIS COPY IS PROVIDED ON A RESTRICTED BASIS AND IS NOT TO BE USED IN ANY WAY DETRIMENTAL TO THE INTERESTS OF PANDUIT CORP.

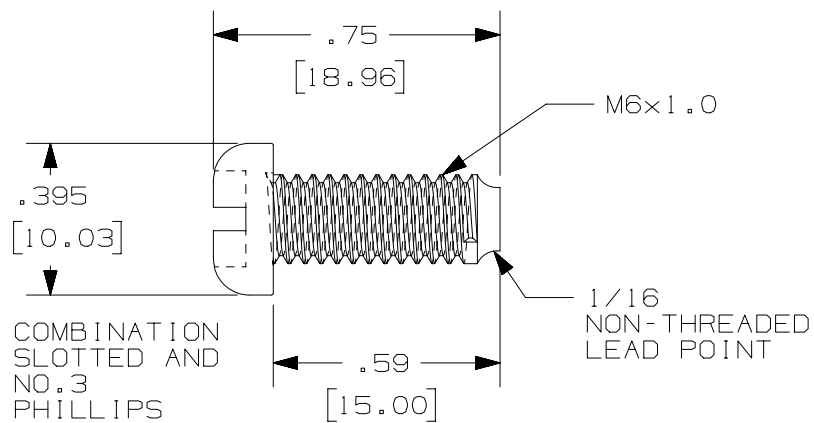

CAGE NUT REMOVED FROM VIEW FOR CLARITY

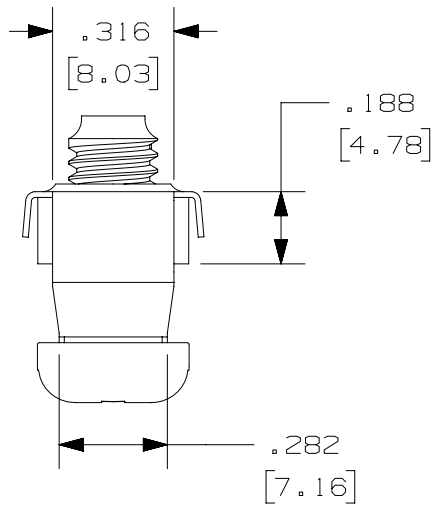
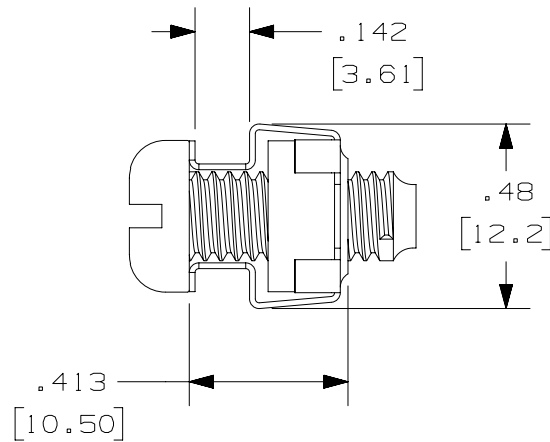
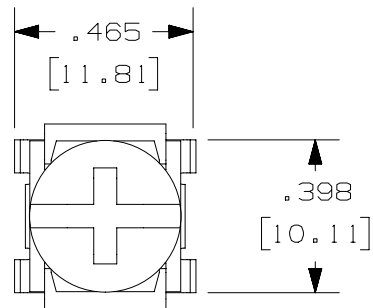

PANDUIT P/N	WEIGHT
CNWSM6-C	1.90 LBS/EACH 0.86 Kg/EACH

- NOTES:
- VISIT OUR ON-LINE CATALOG AT WWW.PANDUIT.COM FOR A LIST OF CURRENT PARTS APPLICABLE FOR USE WITH THIS PRODUCT.
 - DIMENSIONS IN PARENTHESES ARE METRIC (mm).
 - PARTS SUPPLIED:
(100)- M6x1.0 ROUND HEAD SCREW
(100)- M6 CAGE NUT

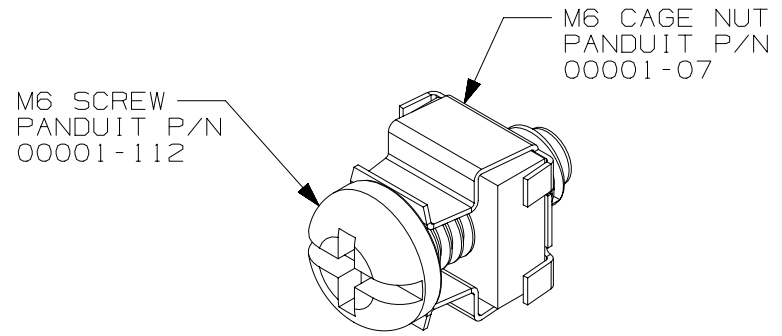

PARTS SHOWN ASSEMBLED FOR REFERENCE ONLY

MODEL FILENAME	V10119AJ_CNWSM6-C_ASSY_00.PRT
CAD FILENAME/LAYERS	V10119AJ_DC_00A.PRT

PANDUIT CORP. TINLEY PARK, ILLINOIS

M6 CAGE NUT WITH SCREW-KIT
CUSTOMER DRAWING

UNLESS OTHERWISE SPECIFIED, DIMENSIONAL TOLERANCES ARE:		UNLESS OTHERWISE SPECIFIED, ALL DIMENSIONS ARE GIVEN	
INCHES	[METRIC - MILLIMETER]	ANGLE	IN INCHES, THIRD ANGLE PROJECTION.
X.X +/- 0.03	X.X +/- 0.8		
X.XX +/- 0.015	X.X +/- 0.4	+/- 1°	
X.XXX +/- 0.005	X.XX +/- 0.13		

DRAWN BY TKW	MAT'L:	SCALE 2:1
DATE 03-28-07	SEE NOTES	DRAWING NO. 10119-20
CHK'D		DWG A SIZE

00	3-28-07	TKW		RELEASED TO PRODUCTION	10119-20				
REV	DATE	BY	CHK	DESCRIPTION	ECN	R	CUST	SUP	OTH