

P31 – COUPLERS H50

Reference(s): 481562/483562/486562/341213/343213/486213/485230/482219
483219/484006/485232/480224/483224/486224/485224/481626
482626/481565/483565/485225/487476/487478/481179/481180
481181/481182/481183/482304/482305/482306/482307/482308
486014/486015/486016/486017/486018

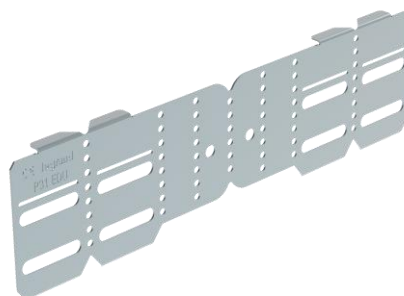

1. USE

All couplers in H50 for cable trays and fittings.

2. RANGE EA COUPLER

■ 2.1 EA Coupler H50-60 PG

Description	Code	Weight		Thickness		Coating
		(Kg)	(lb)	(mm)	(inch)	
P31-EA COUPLER H50-60 PG	481562	0,03	0,07	1,4	0,06	PG

■ 2.2 EA Coupler H50-60 HDG

Description	Code	Weight		Thickness		Coating
		(Kg)	(lb)	(mm)	(inch)	
P31-EA COUPLER H50-60 HDG	483562	0,03	0,07	1,4	0,06	HDG

■ 2.3 EA Coupler H50-60 SS316L

Description	Code	Weight		Thickness		Coating
		(Kg)	(lb)	(mm)	(inch)	
P31-EA COUPLER H50-60 SS316	486562	0,05	0,11	1,5	0,06	SS316L

3. DIMENSION EA COUPLER (mm/inch)

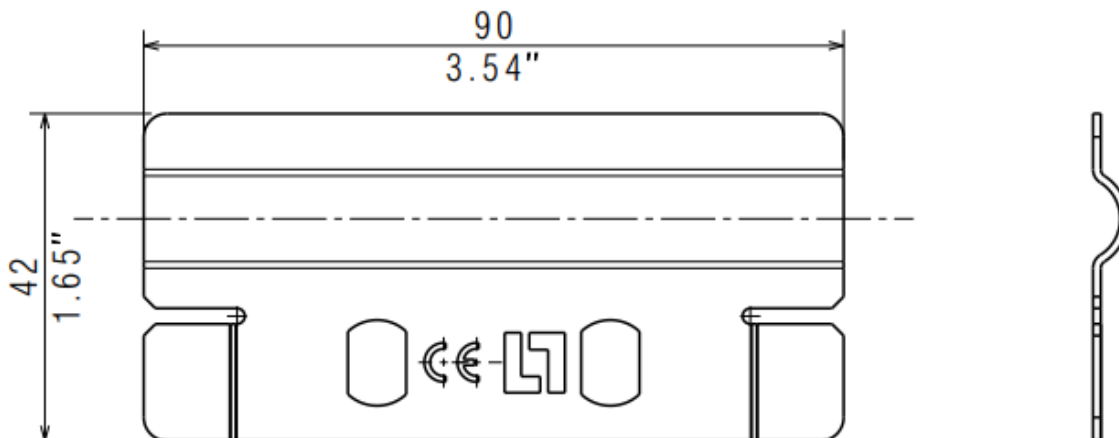

4. RANGE EP COUPLER

■ **4.1 EP Coupler H50-60 PG**

Description	Code	Weight		Thickness		Coating
		(Kg)	(lb)	(mm)	(inch)	
P31-COUPLER EP50-60 PG	341213	0,10	0,22	1,4	0,06	PG

■ **4.2 EP Coupler H50-60 HDG**

Description	Code	Weight		Thickness		Coating
		(Kg)	(lb)	(mm)	(inch)	
P31-COUPLER EP50-60 HDG	343213	0,11	0,24	1,5	0,06	HDG

■ **4.3 EP Coupler H50-60 SS316L**

Description	Code	Weight		Thickness		Coating
		(Kg)	(lb)	(mm)	(inch)	
P31-COUPLER EP50-60 SS316	486213	0,10	0,22	1,5	0,06	SS316L

■ **4.4 EP Coupler H50-60 ZNMG**

Description	Code	Weight		Thickness		Coating
		(Kg)	(lb)	(mm)	(inch)	
P31-COUPLER EP50-60 ZM	485230	0,10	0,22	1,5	0,06	ZNMG

5. DIMENSIONS EP COUPLER (mm/inch)

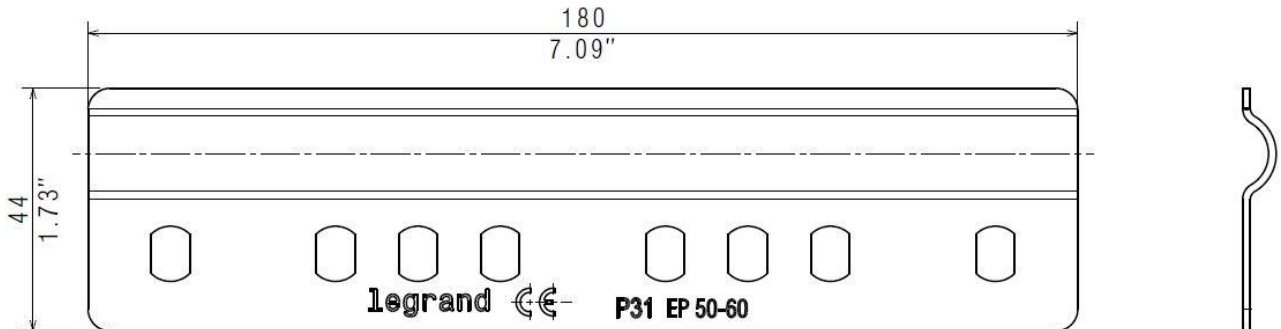

6. RANGE ER COUPLER

■ **6.1 ER Coupler H50-60 PG**

Description	Code	Weight		Thickness		Coating
		(Kg)	(lb)	(mm)	(inch)	
P31-COUPLER ER H60 PG	482219	0,10	0,22	1,4	0,06	PG

■ **6.2 ER Coupler H50-60 HDG**

Description	Code	Weight		Thickness		Coating
		(Kg)	(lb)	(mm)	(inch)	
P31-COUPLER ER H60 HDG	483219	0,11	0,24	1,4	0,06	HDG

■ **6.3 ER Coupler H50-60 SS304**

Description	Code	Weight		Thickness		Coating
		(Kg)	(lb)	(mm)	(inch)	
P31-COUPLER ER H60 SS304	484006	0,11	0,24	1,5	0,06	SS304

■ **6.4 ER Coupler H50-60 ZNMG**

Description	Code	Weight		Thickness		Coating
		(Kg)	(lb)	(mm)	(inch)	
P31-COUPLER ER H60 ZM	485232	0,11	0,24	1,5	0,06	ZNMG

7. DIMENSIONS ER COUPLER (mm/inch)

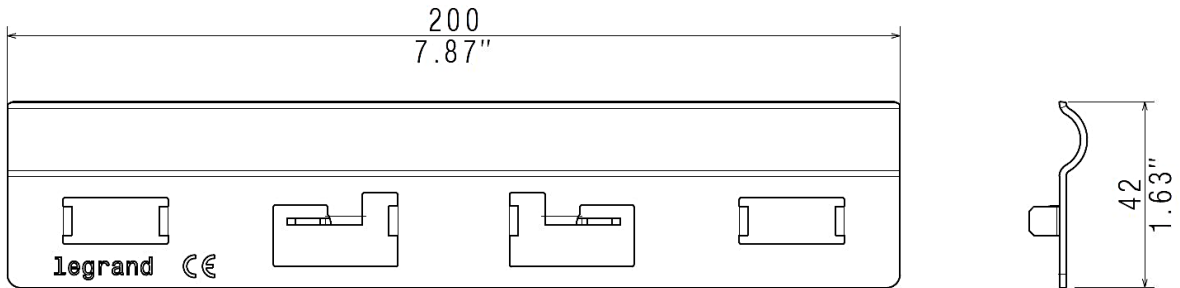

8. RANGE DU COUPLER

■ **8.1 EDU Coupler H50 PG**

Description	Code	Weight		Thickness		Coating
		(Kg)	(lb)	(mm)	(inch)	
P31-UNIVERSAL COUPLER EDU H50 PG	480224	0,13	0,29	0,95	0,04	PG

■ **8.2 EDU Coupler H50 HDG**

Description	Code	Weight		Thickness		Coating
		(Kg)	(lb)	(mm)	(inch)	
P31-UNIVERSAL COUPLER EDU H50 HDG	483224	0,14	0,31	0,95	0,04	HDG

■ **8.3 EDU Coupler H50 SS316L**

Description	Code	Weight		Thickness		Coating
		(Kg)	(lb)	(mm)	(inch)	
P31-UNIVERSAL COUPLER EDU H50 SS316L	486224	0,13	0,29	1,0	0,04	SS316L

■ **8.4 EDU Coupler H50 ZNMG**

Description	Code	Weight		Thickness		Coating
		(Kg)	(lb)	(mm)	(inch)	
P31-UNIVERSAL COUPLER EDU H50 ZM	485224	0,13	0,29	1,0	0,04	ZNMG

9. DIMENSIONS EDU COUPLER (mm/inch)

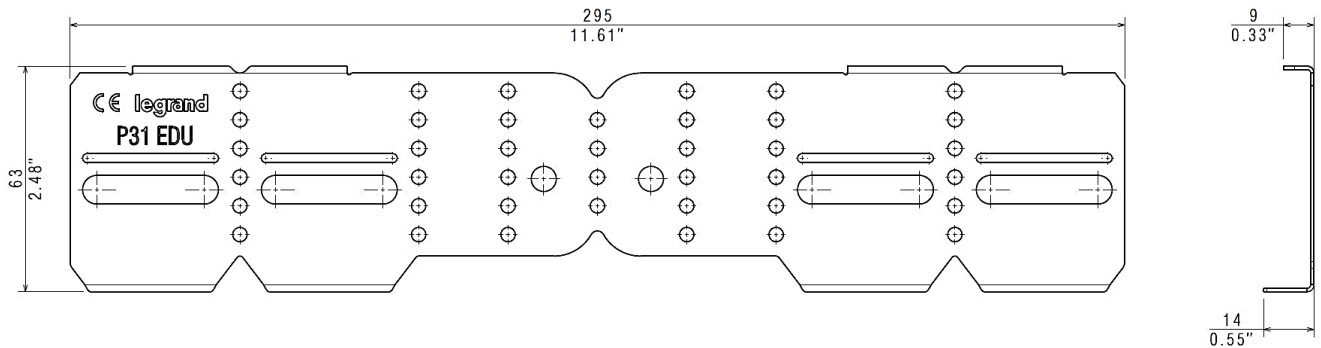

10. RANGE TWIST COUPLER

■ **10.1 TWIST Coupler H50 PG**

Description	Code	Weight		Thickness		Coating
		(Kg)	(lb)	(mm)	(inch)	
P31- TWIST COUPLER H50MM PG	481626	0,04	0,08	0,95	0,04	PG

■ **10.2 TWIST Coupler H50 HDG**

Description	Code	Weight		Thickness		Coating
		(Kg)	(lb)	(mm)	(inch)	
P31- TWIST COUPLER H50MM HDG	482626	0,04	0,10	0,95	0,04	HDG

11. DIMENSIONS TWIST COUPLER (mm/inch)

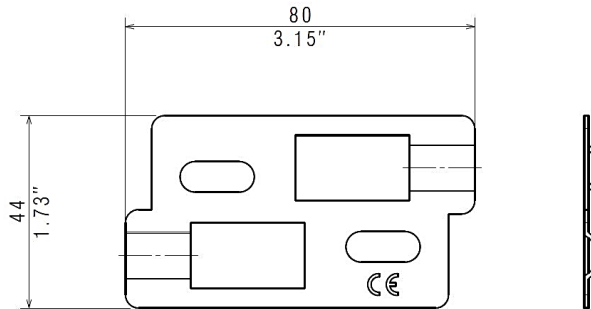

12. RANGE EV COUPLER

■ **12.1 EV Coupler H50 PG**

Description	Code	Weight		Thickness		Coating
		(Kg)	(lb)	(mm)	(inch)	
P31-HINGED COUPLER EV H50 PG	481565	0,11	0,24	0,75	0,03	PG

■ **12.2 EV Coupler H50 HDG**

Description	Code	Weight		Thickness		Coating
		(Kg)	(lb)	(mm)	(inch)	
P31-HINGED COUPLER EV H50 HDG	483565	0,11	0,24	0,75	0,03	HDG

■ **12.3 EV Coupler H50 ZNMG**

Description	Code	Weight		Thickness		Coating
		(Kg)	(lb)	(mm)	(inch)	
P31-HINGED COUPLER EV H50 ZM	485225	0,11	0,24	0,80	0,03	ZNMG

13. DIMENSIONS EV COUPLER (mm/inch)

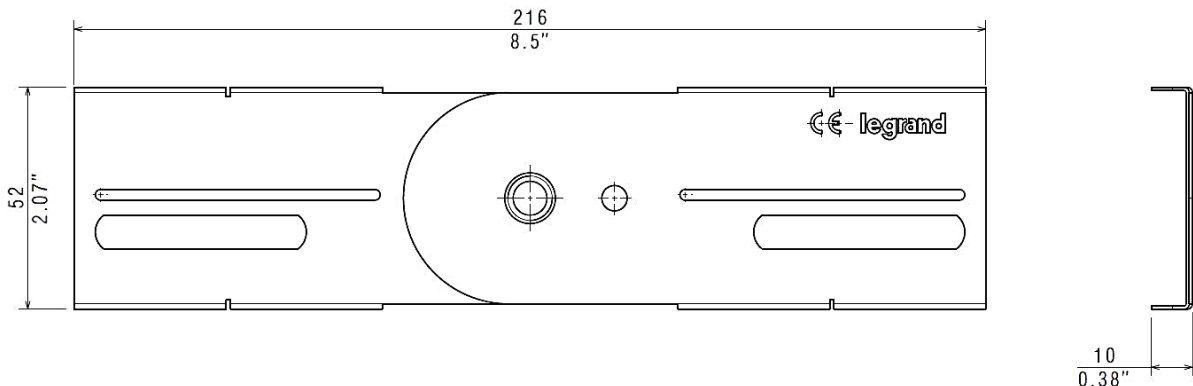

14. RANGE EXTERNAL COUPLER

■ **14.1 EXTERNAL Coupler H50 PG**

Description	Code	Weight		Thickness		Coating
		(Kg)	(lb)	(mm)	(inch)	
P31-HD EXTERNAL COUPLER H50 PG	487476	0,34	0,75	2,00	0,08	PG

■ **14.2 EXTERNAL Coupler H50 HDG**

Description	Code	Weight		Thickness		Coating
		(Kg)	(lb)	(mm)	(inch)	
P31-HD EXTERNAL COUPLER H50 HDG	487478	0,38	0,84	2,00	0,08	HDG

15. DIMENSIONS EXTERNAL COUPLER (mm/inch)

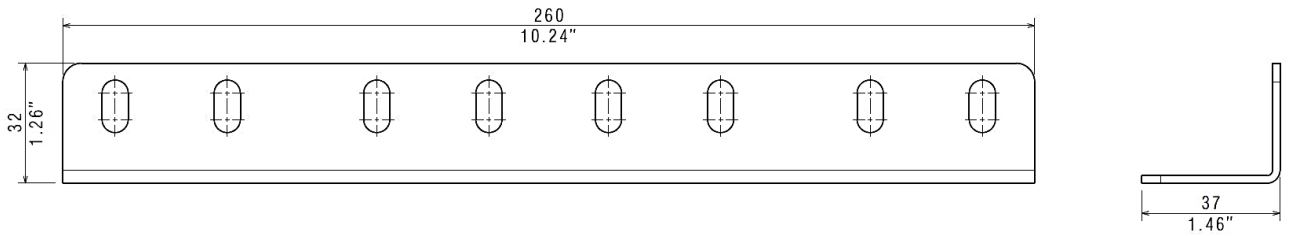

16. RANGE PERFORATED BOTTOM COUPLER

■ 16.1 Perforated bottom coupler PG

Description	Code	Width		Weight		Thickness		Coating
		(mm)	(inch)	(Kg)	(lb)	(mm)	(inch)	
P31-PERFORATED BOTTOM COUPLER 200 PG	481179	130,0	5,12	0,28	0,62	1,5	0,06	PG
P31-PERFORATED BOTTOM COUPLER 300 PG	481180	230,0	9,06	0,45	0,99	1,5	0,06	PG
P31-PERFORATED BOTTOM COUPLER 400 PG	481181	320,0	12,60	0,64	1,42	1,5	0,06	PG
P31-PERFORATED BOTTOM COUPLER 500 PG	481182	420,0	16,54	0,86	1,89	1,5	0,06	PG
P31-PERFORATED BOTTOM COUPLER 600 PG	481183	520,0	20,47	1,07	2,36	1,5	0,06	PG

■ 16.2 Perforated bottom coupler HDG

Description	Code	Width		Weight		Thickness		Coating
		(mm)	(inch)	(Kg)	(lb)	(mm)	(inch)	
P31-PERFORATED BOTTOM COUPLER 200 HDG	482304	130,0	5,12	0,28	0,62	1,5	0,06	HDG
P31-PERFORATED BOTTOM COUPLER 300 HDG	482305	230,0	9,06	0,45	0,99	1,5	0,06	HDG
P31-PERFORATED BOTTOM COUPLER 400 HDG	482306	320,0	12,60	0,64	1,42	1,5	0,06	HDG
P31-PERFORATED BOTTOM COUPLER 500 HDG	482307	420,0	16,54	0,86	1,89	1,5	0,06	HDG
P31-PERFORATED BOTTOM COUPLER 600 HDG	482308	520,0	20,47	1,07	2,36	1,5	0,06	HDG

■ 16.3 Perforated bottom coupler SS316L

Description	Code	Width		Weight		Thickness		Coating
		(mm)	(inch)	(Kg)	(lb)	(mm)	(inch)	
P31-PERFORATED BOTTOM COUPLER 200 SS316L	486014	130,0	5,12	0,28	0,62	1,5	0,06	SS316L
P31-PERFORATED BOTTOM COUPLER 300 SS316L	486015	230,0	9,06	0,45	0,99	1,5	0,06	SS316L
P31-PERFORATED BOTTOM COUPLER 400 SS316L	486016	320,0	12,60	0,64	1,42	1,5	0,06	SS316L
P31-PERFORATED BOTTOM COUPLER 500 SS316L	486017	420,0	16,54	0,86	1,89	1,5	0,06	SS316L
P31-PERFORATED BOTTOM COUPLER 600 SS316L	486018	520,0	20,47	1,07	2,36	1,5	0,06	SS316L

17. DIMENSIONS PERFORATED BOTTOM COUPLER (mm/inch)

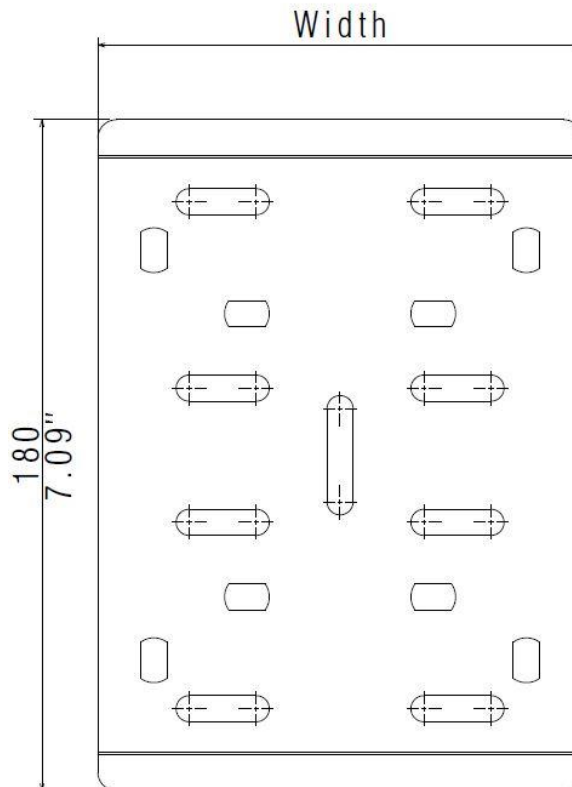

18. INSTALLATION

■ 18.1 Screw

Use screws M6x12 tightened at 11Nm

Reference(s): 341895/ 03V1M610Z (PG)
485035 (Zn-Ni)
346895/ 03V1M610L (SS316L)

■ 18.2 EA Coupler installation

Slide together the two fittings and add 2pc of EA couplers height 50-60 using 2 screws M6x12 on each coupler.

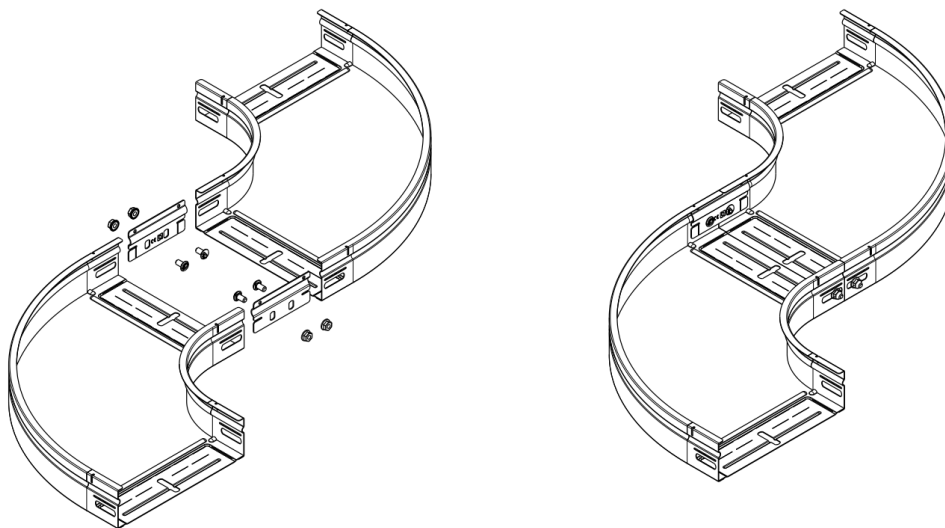

■ 18.3 EP Coupler installation

Use 2pc EP coupler, assembled using 4 screws M6x12 on each coupler.

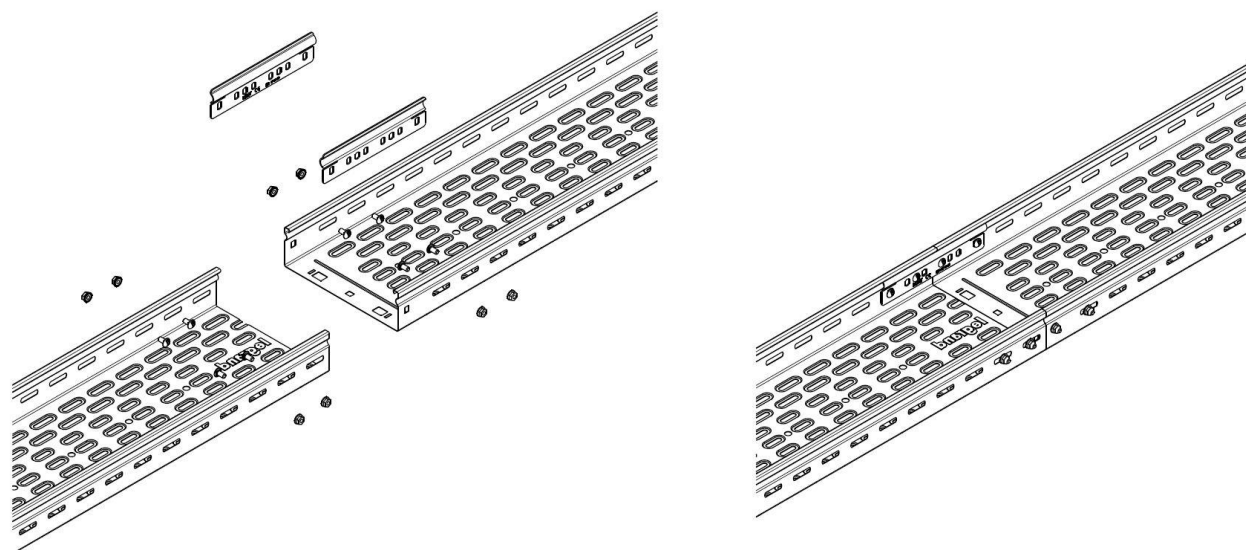

■ 18.4 ER Coupler installation

The ER coupler is assembled bending the external wings of the coupler using a pliers.

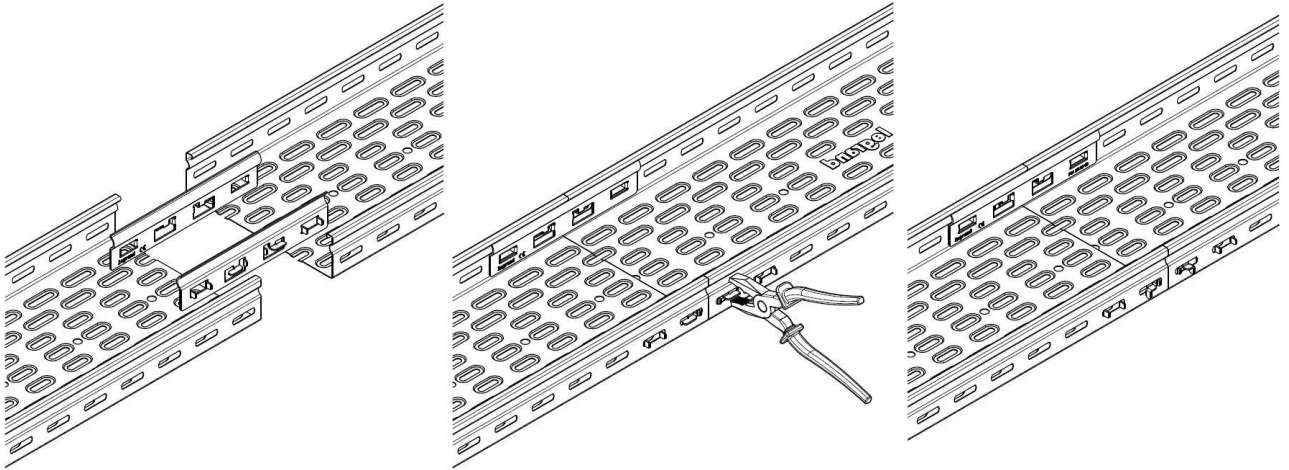

■ 18.5 EDU Coupler installation

Use 2pc EDU coupler, assembled using 4 screws M6x12 on each coupler.

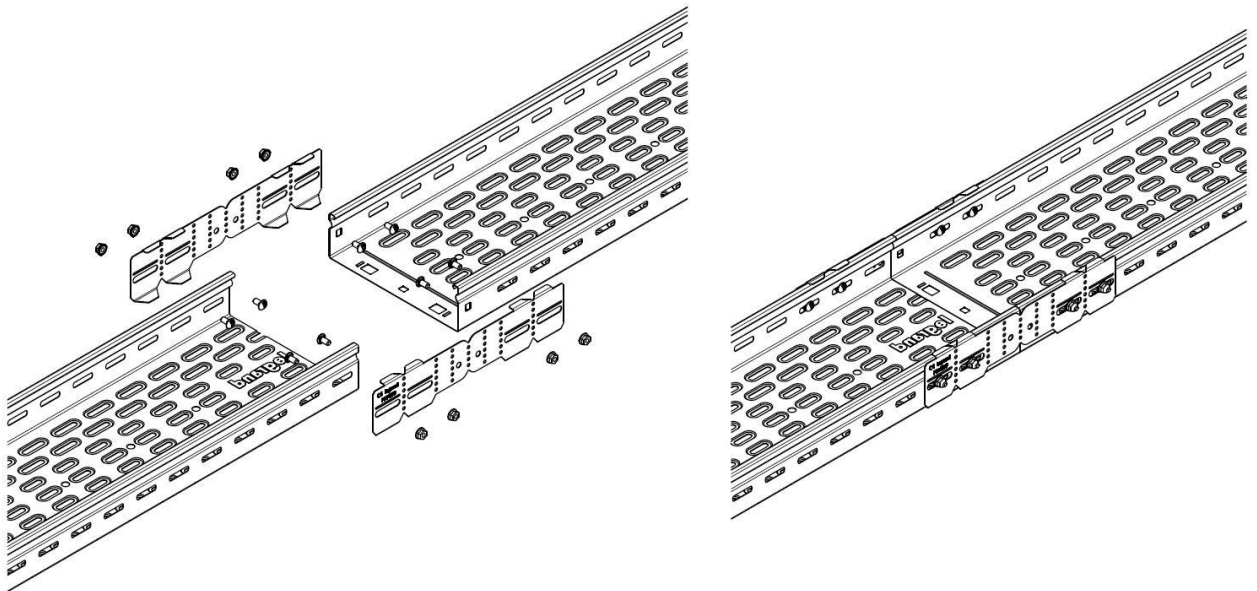

■ 18.6 TWIST Coupler installation

Use 2pc TWIST coupler, assembled using 2 screws M6x12 on each coupler.

Using this coupler, you can insert the next cable tray with the bottom upside down as you can see in the pictures below.

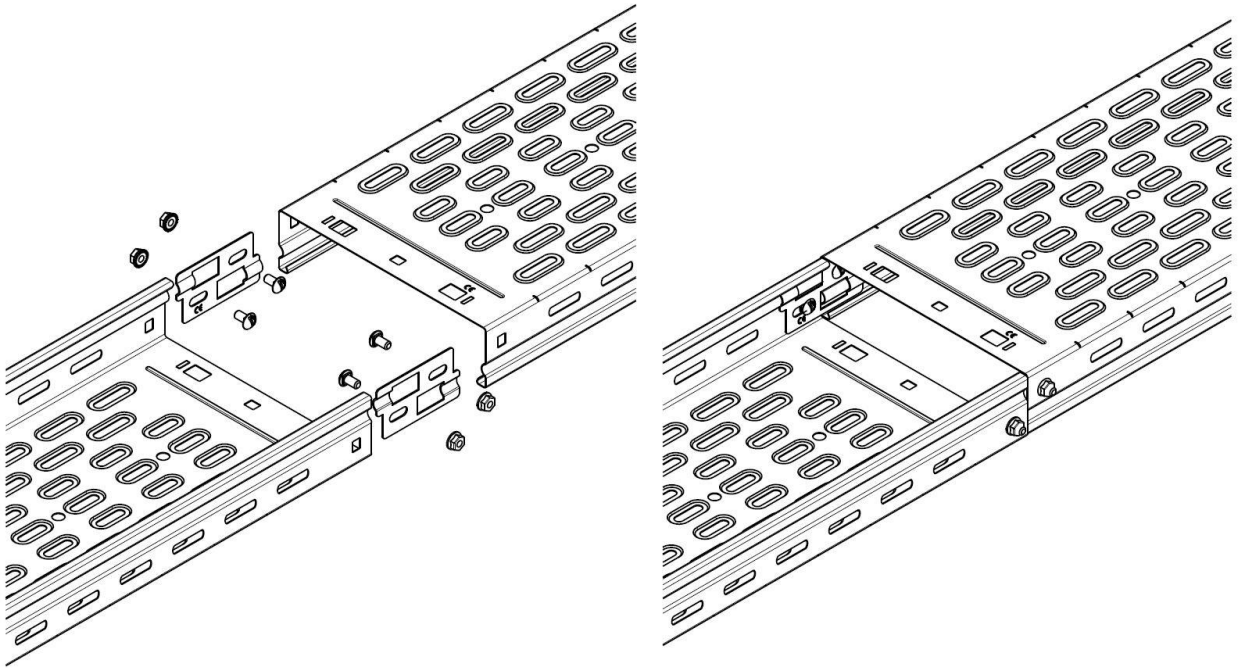

■ 18.7 EV Coupler installation

Use 2pc EV coupler, assembled using 2 screws M6x12 on each coupler.

The vertical coupler is used to connect the side wall when bending cable trays in vertical direction. This allows the installation the change of height or forming an articulated vertical bend.

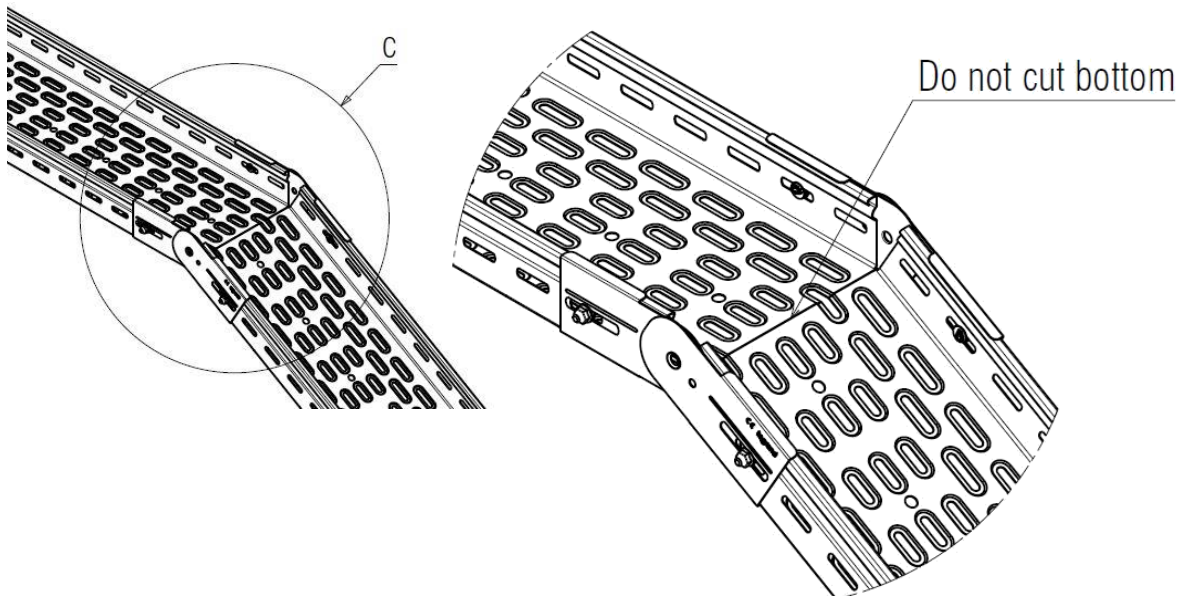

■ 18.8 EXTERNAL Coupler installation

Use 2pc EXTERNAL coupler, assembled using min. 4 screws M6x12 on each coupler.

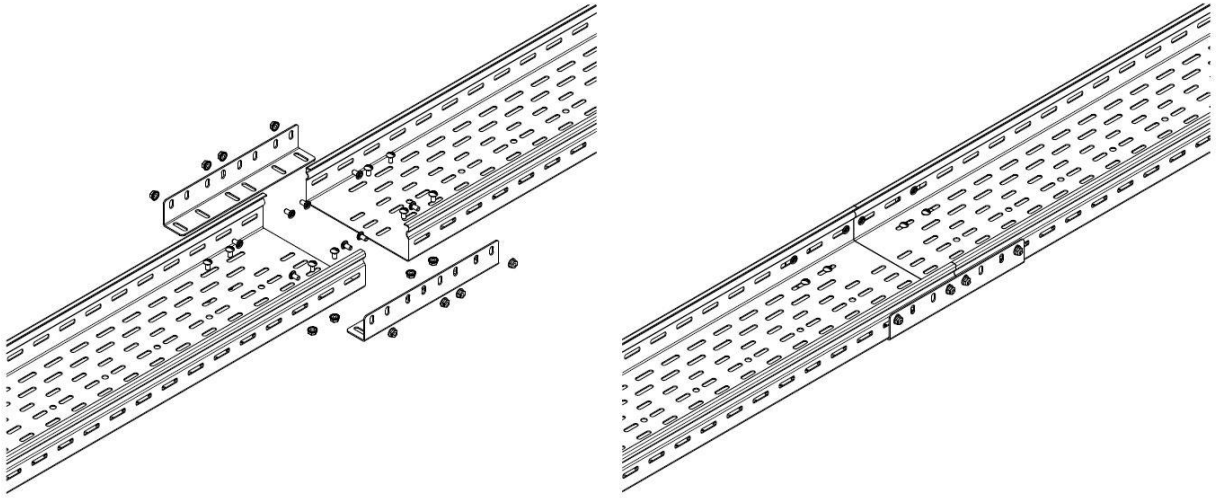

■ 18.9 Perforated bottom coupler

Join cable tray as a standard installation.

Put an extra bottom plate using 5 additional screws M6x12 to improve the safety working load.

For application on blind bottom drill 4 holes Ø 7mm.

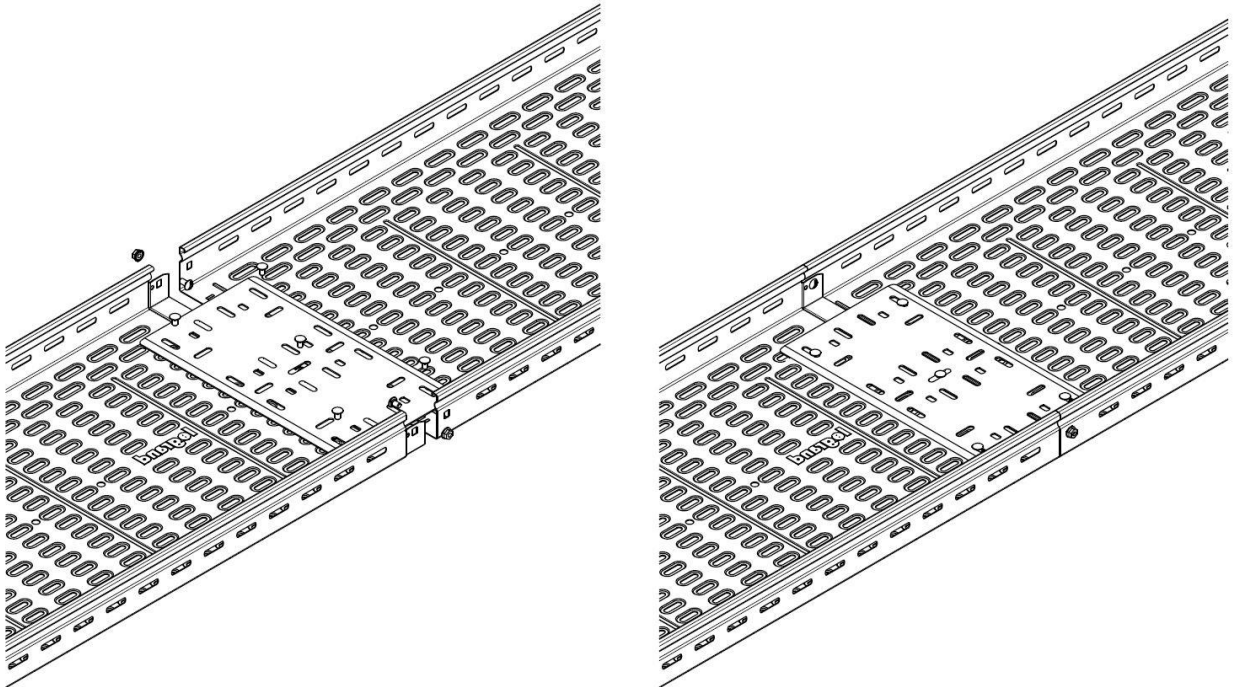

19. TECHNICAL DATA■ **19.1 Climatic characteristics**

Storage and operating temperature: - 20° C à + 120° C

■ **19.2 Material characteristics**

Material finish	Material	Standard	Resistance class against corrosion
PG	DX51D + Z200	EN 10346	Classe 3 - CEI 61537
BLUE	DX51D + Z200	EN 10346	Classe 3 - CEI 61537
HDG	DC 01	EN 10130	Classe 6 - CEI 61537
SS304	X5CrNi18-10	EN 10 088-2	Classe 9A - CEI 61537
SS316L	X2CrNiMo17-12-2	EN 10 088-2	Classe 9B - CEI 61537
ZNMG	DX51D + ZM310 A-C	EN 10364	Classe 8 - CEI 61537

20. CONFORMITY - CERTIFICATION

Comply with CEI 61537 Cable tray systems

Certification: CE, IMQ