

(EN)

Automatic Transfer Switching Equipment Controller

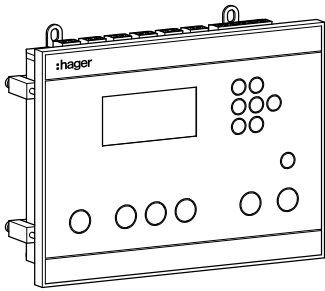

HZI855



Risk of electrocution, burns or injury to persons and/or damage to equipment. Risk of damaging the device in case the product is dropped or damaged in any way it is recommended to replace the complete product.



Preliminary operations

Check the following upon delivery and after removal of the packaging:

- Packaging and contents are in good condition.
- The product reference corresponds to the order.
- Contents should include:
 - 1 HZI855 ATSE controller
 - 4 door mounting screws
 - 4 backplate mounting feet
- Accessory: IP65 gasket: ref. HZI501

This Quick Start is intended for personnel trained in the installation and commissioning of this product. For further details refer to the product instruction manual available on www.hager.com.

This product must always be installed and commissioned by qualified and approved personnel. Maintenance and servicing operations should be performed by trained and authorised personnel.

Do not handle any control or power cables connected to the product when voltage may be, or may become present on the product, directly through the mains or indirectly through external circuits.

Always use an appropriate voltage detection device to confirm the absence of voltage.

Ensure that no metal objects are allowed to fall in the cabinet (risk of electrical arcing).

Failure to observe good engineering practises as well as to follow these safety instructions may expose the user and others to serious injury or death.

Installation and commissioning controller

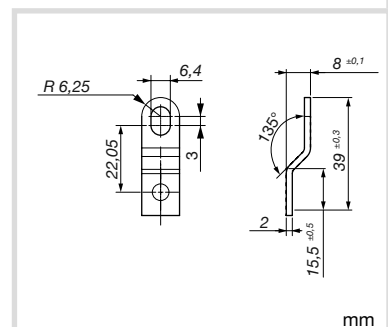
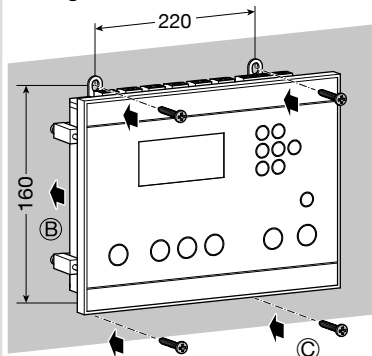
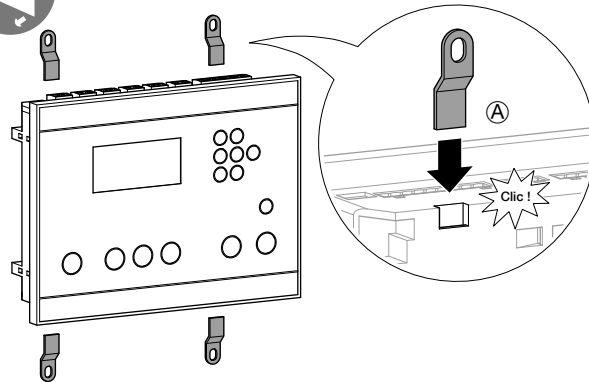
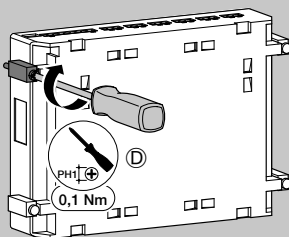
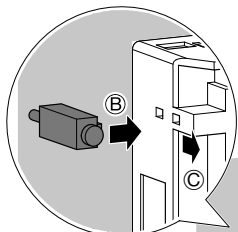
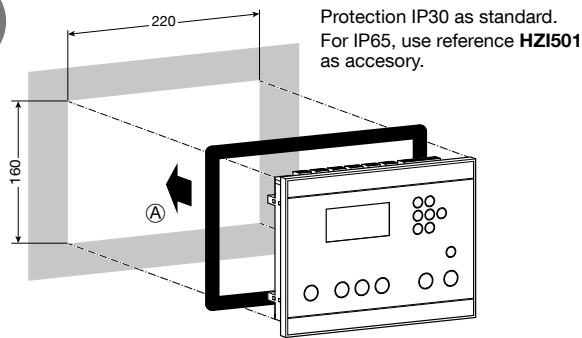



Dimensions

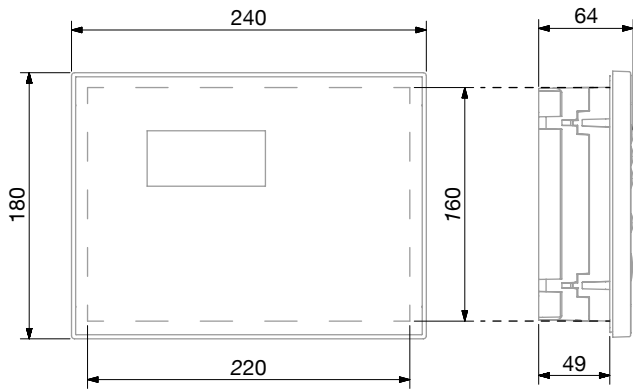

mm



Networks

Type of networks

Power Supply:

The HZI855 controller is Self-powered from the voltage sensing of any available source, and may also be powered (as a backup from saved source) from the DC auxiliary power input (24 VDC).

Dual Power Supply/Sensing

The HZI855 controller will be automatically supplied from the voltage sensing connectors of both sources thanks to an internal DPS (dual power supply) module that in case main source failure, will immediately switch to the secondary source supply the device.

NOTE: The nominal auxiliary power supply feeding the sensing terminals must be within the limits of 88 ⇒ 576 VAC.

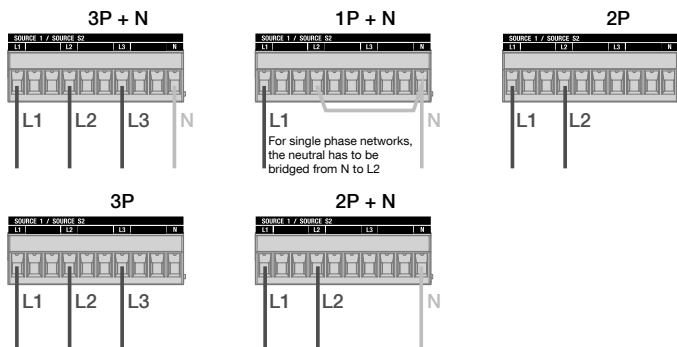

NOTE: The HZI855 must include a SCPD such as fuses on each phase of the voltage sensing control wiring. 1A gG fuses are recommended.

Metering and sensing detail

NETWORK TYPE	1P+N	2P	2P+N	3P	3P+N	3P+N / 1P+N
Source 1	1 phase 2 wire	2 phase 2 wire	2 phase 3 wire	3 phase 3 wire	3 phase 4 wire	3 phase 4 wire
Source 2						1 phase 2 wire



Loss of neutral: will be detected in all cases except for balanced networks with balanced loads. In Breaker mode: the use of undervoltage release (see wiring diagram) can prevent this situation.



HZI855 and HIB4xxM for network / network application type

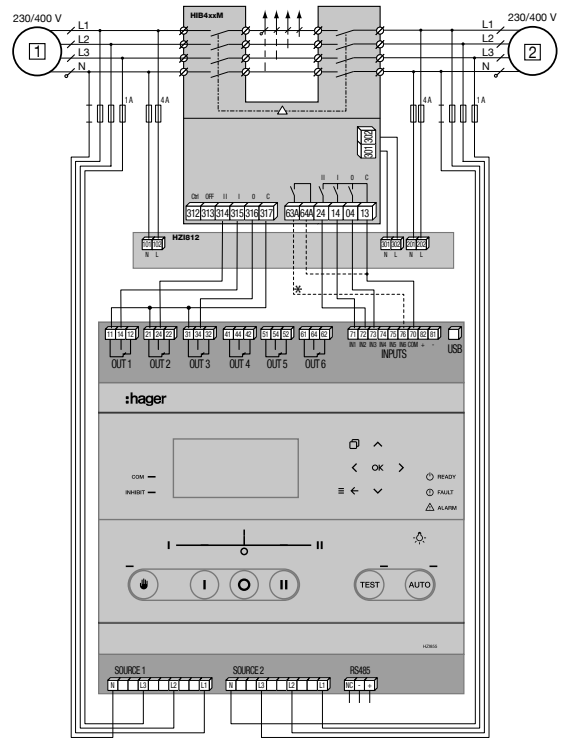

for network / genset application type

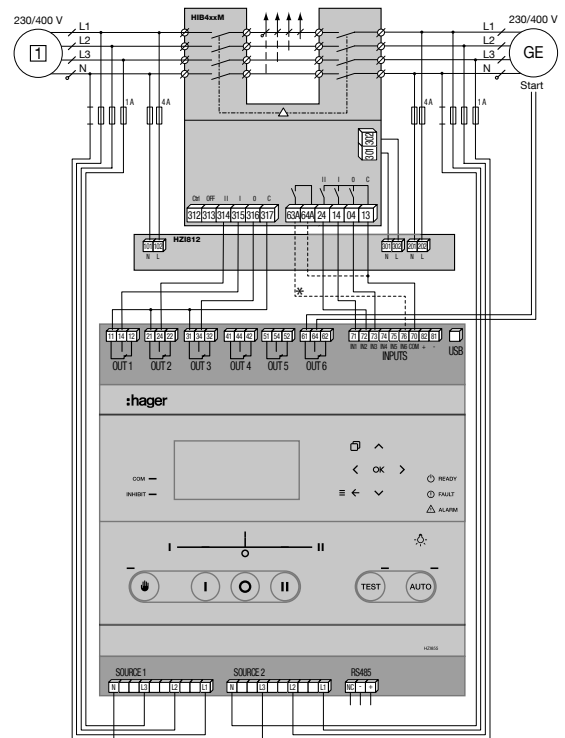

Default configuration for Inputs and Outputs for "HIB4xxM" mode:

- IN1: Switch is in position 1
- IN2: Switch is in position 2
- IN3: Switch is in position 0
- IN4: Inhibit
- IN5: Manual retransfer
- IN6: RTSE in manual

- OUT1: Order to switch in position 1
- OUT2: Order to switch in position 2
- OUT3: Order to switch in position 0
- OUT4: S1 Available
- OUT5: S2 Available
- OUT6: Order to start Genset

* The use of this input is optional, when used IN6 should be configured to "COVER OPEN" in mode "NC".

This configuration is defined with source I as the priority source. This diagram covers most application cases, the inputs and outputs are configured by default for this installation.



HZI855 with MCCB for network / network application type

HZI855 with MCCB for network / genset application type

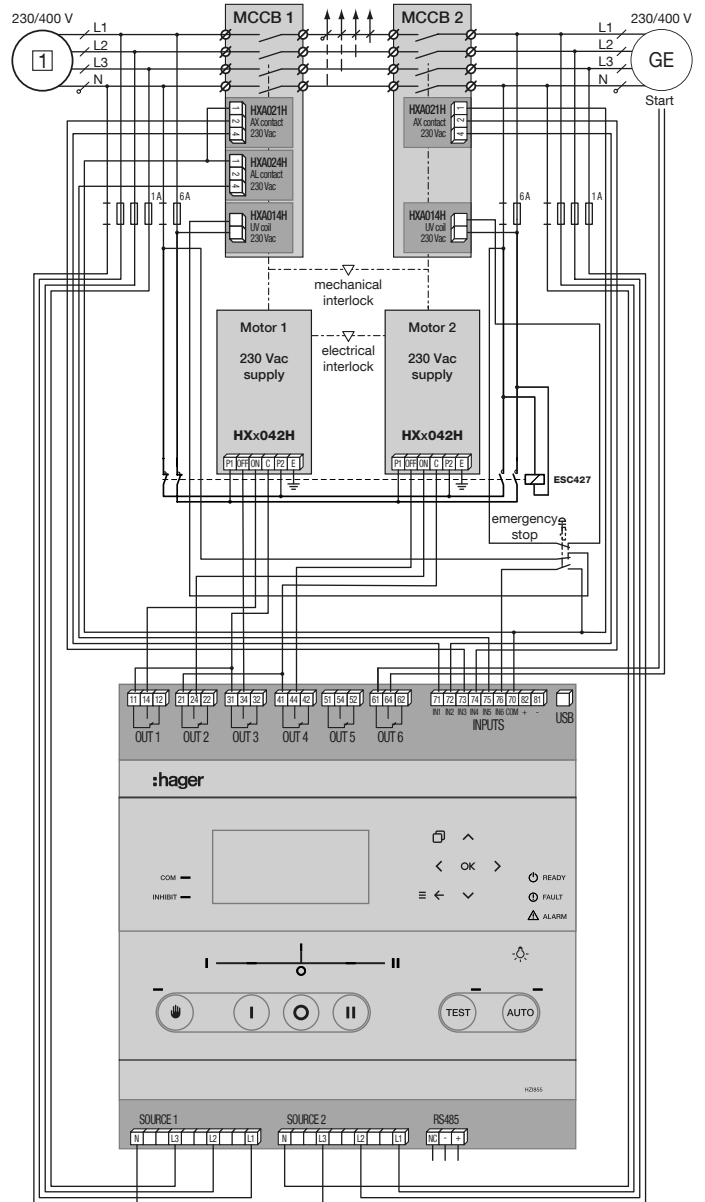
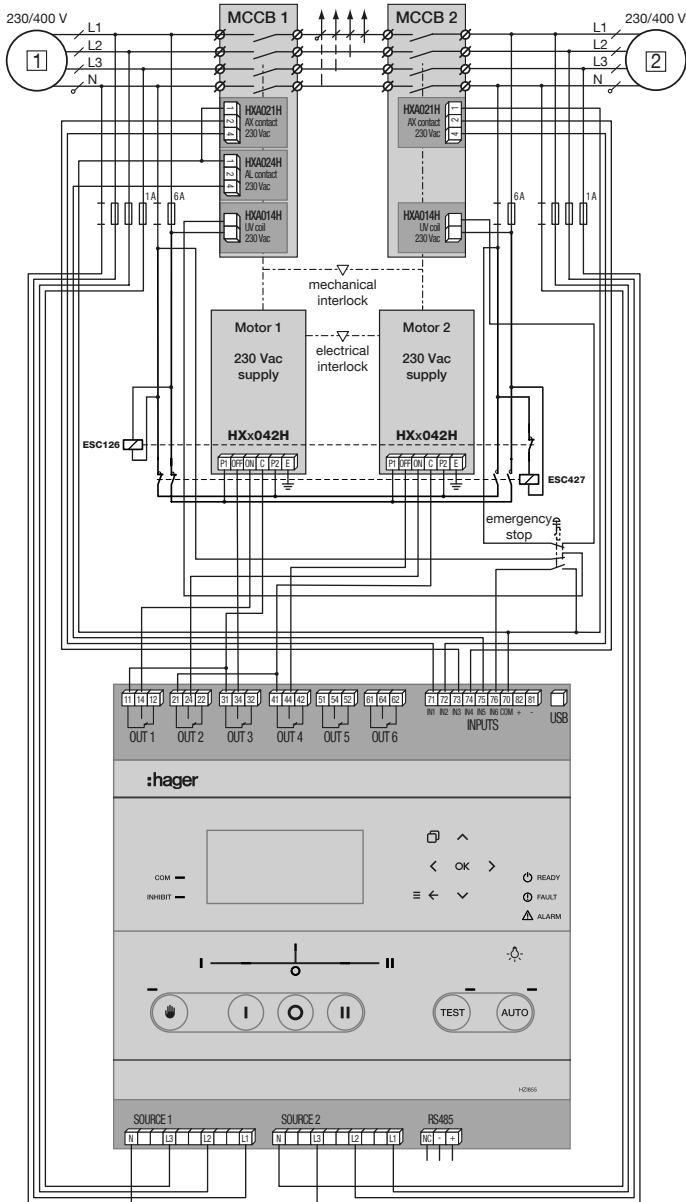

Note: indicated references are used for MCCB x250/P250 and x630/P630.

Default configuration for Inputs and Outputs for "Breaker" mode:

- IN1: Breaker 1 is in position ON
- IN2: Breaker 2 is in position ON
- IN3: Breaker 1 is in position OFF
- IN4: Breaker 2 is in position OFF
- IN5: Breaker 1 is in position TRIP
- IN6: Emergency stop
- OUT1: Order to close Breaker 1
- OUT2: Order to close Breaker 2
- OUT3: Order to open Breaker 1
- OUT4: Order to open Breaker 2
- OUT5: NONE
- OUT6: Order to start Genset

This configuration is defined with source I as the priority source. This diagram covers most application cases, the inputs and outputs are configured by default for this installation, the actions of the controller will be:

- In the event of neutral loss from source I: the undervoltage coil will trip the circuit breaker for source I making it unavailable (ALarm contact on input 5) to switch to secondary source II.
- In the event of tripping via the emergency stop button: the undervoltage coil will trip the circuit breaker of the source I making it unavailable (ALarm contact on input 5) BUT the controller will switch to " total inhibition "(input 6 activated), that is to say that the load will no longer be supplied without manual intervention on the controller in order to acknowledge this fault.

After acknowledgment, the controller will switch to priority source I if available, otherwise to secondary source II.



Controller wiring

Bottom view

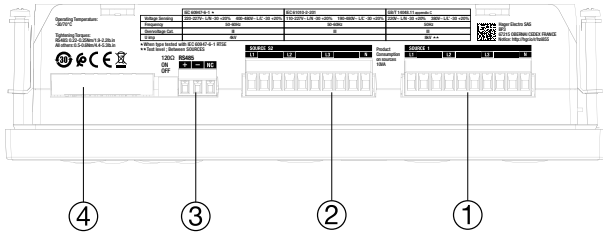

1. Voltage sensing source 1.
2. Voltage sensing source 2.
3. RS485.
4. RTC battery

Top view

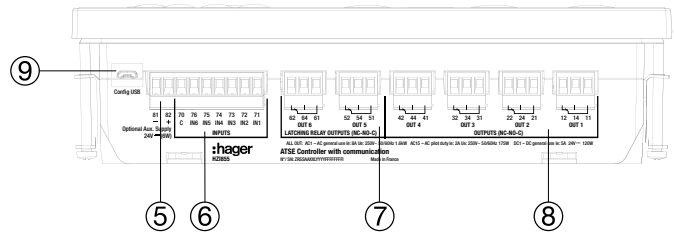

5. Optional Aux. Supply 24 VDC.
6. Programmable INPUTS.
7. Programmable OUTPUTS.
8. Latching relays.
9. Config USB.

Cabling Output relays 1-4

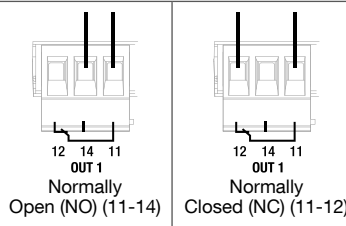

Cabling Output Latching relays 5 & 6

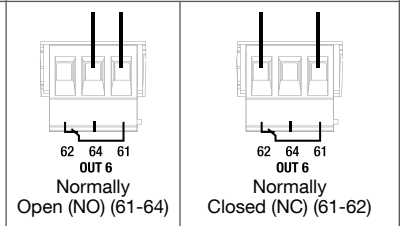

Controller config	STATE (relay)	Cabling Output relays 1-4		Cabling Output Latching relays 5 & 6	
		Normally Open (NO) (11-14)	Normally Closed (NC) (11-12)	Normally Open (NO) (61-64)	Normally Closed (NC) (61-62)
Output configured as NO NO by default	OFF (not active)	Open	Closed	Open	Closed
	ON (activated by firmware)	Closed	Open	Closed	Open
	Controller not supplied	Open	Closed	Closed*	Open*
Output configured as NC	OFF (not active)	Closed	Open	Closed	Open
	ON (activated by firmware)	Open	Closed	Open	Closed
	Controller not supplied	Open	Closed	Closed*	Open*

* HZ1855 controller includes two bi-stable relays with backup energy, when the controller loses all sources of power supply outputs 5 and 6 will automatically activate (NO contact will close and NC contact will open). This is a safety feature designed to ensure power availability to the load in Main-Genset or Genset-Genset application by forcing generators to start in case of total power loss. It is highly recommended to configure the outputs 5 and 6 to take benefit from this function.

TYPE	TERMINAL N°	DESCRIPTION	BY DEFAULT	CONFIGURATION CHANGES WHEN CHANGING RTSE TECHNOLOGY		CHARACTERISTICS	RECOMENDED CROSS SECTION
			Breakers	HIB4xxM	Contactors		
Inputs	71	IN1: programmable input	Breaker 1 is in position ON	Switch is in position 1	Contactor 1 is in position ON	Do not connect to any power supply from terminal 70 common point. Configurable type NO or NC - NO by default	1.5-2.5 mm ² Tightening torque 0.5-0.6 Nm 4.4-5.3 Lb.in
	72	IN2: programmable input	Breaker 2 is in position ON	Switch is in position 2	Contactor 2 is in position ON		
	73	IN3: programmable input	Breaker 1 is in position OFF	Switch is in position 0	-		
	74	IN4: programmable input	Breaker 2 is in position OFF	Inhibit	-		
	75	IN5: programmable input	Breaker 1 is in position TRIP	Manual retransfer	-		
	76	IN6: programmable input	Emergency stop	RTSE in manual	-		
	70	Common point for inputs					
Outputs		Logic	Impulse	Impulse	Maintained	Dry contacts 8 A / 277 VAC 50/60 Hz 5 A / 24 VDC Configurable type NO or NC - NO by default	1.5-2.5 mm ² Tightening torque 0.5-0.6 Nm 4.4-5.3 Lb.in
	12/14/11	OUT1: programmable output	Order to close Breaker 1	Order to switch in position 1	Order to close Contactor 1		
	22/24/21	OUT2: programmable output	Order to close Breaker 2	Order to switch in position 2	Order to close Contactor 2		
	32/34/31	OUT3: programmable output	Order to open Breaker 1	Order to switch in position 0	-		
Latching relays		Logic	Impulse	Impulse	Maintained		
	52/54/51	OUT 5: genset start relay / programmable output	-	S2 Available	-		
	62/64/61	OUT 6: genset start relay / programmable output	Order to start Genset	Order to start Genset	-		
Serial connection	RS485	Connection RS485 -: negative terminal of RS485 bus +: positive terminal of RS485 bus NC: ground	-	-	-	RS485 bus insulated	Modbus cable 25 m = HTG485H LYCY shielded twisted pair 0.14 to 1.5 mm ² / Tightening torque 0.22-0.25 Nm 1.9-2.2 Lb.in
Aux power supply	81/82	-: negative terminal for aux supply +: positive terminal for aux supply	-	-	-	12-24 VDC	Tightening torque 0.5-0.6 Nm 4.4-5.3 Lb.in



Interface

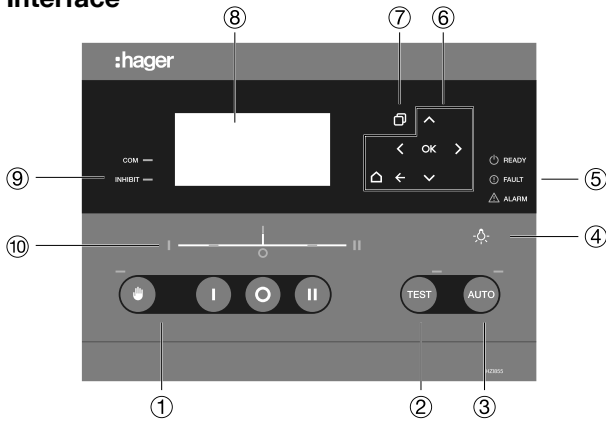

1. Manual operation buttons and indicator.
2. Test button and indicator.
3. Automatic button and LED indicator.
4. Lamp test button.
5. Power, Fault and alarm LED.
6. Navigation buttons.
7. Change dashboard.
8. LCD display.
9. LED COM & Inhibit.
10. Source and switch synoptic.

SMART WIZARD CONFIG:

When powered for the first time the controller will prompt the user to configure using the wizard.
To access the wizard input code 1000 then the configuration will go as follow:



For advanced configuration go to parameters menu.



Visualization

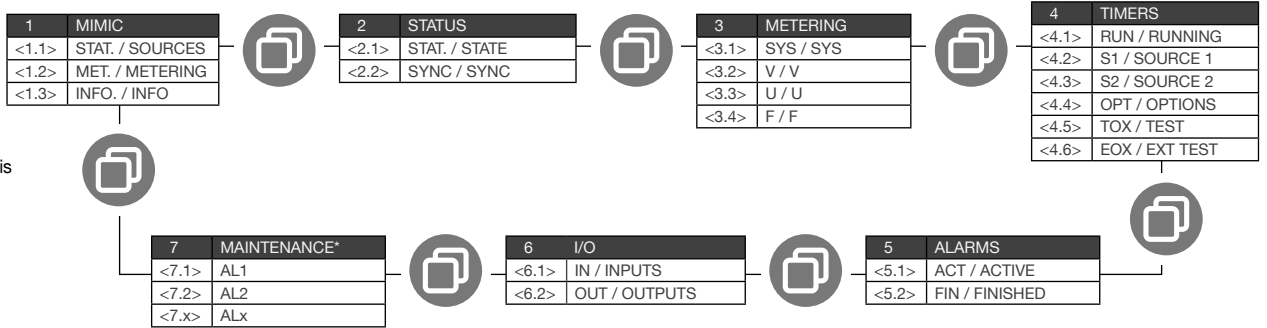

- Short press on this button to cycle the dashboards.

* The maintenance dashboard allows users to visualise all maintenance alarms configured.



Menus & programming

MAIN MENU	
CONTROL	
LOG	
STATISTICS	
GENSET SCHEDULER	
PARAMETERS	
SPECIFIC FUNCTIONS	
MAINTENANCE	
ABOUT	

CONTROL	
MODE / POSITION	
TEST	
MANUAL RETRANSFER	

LOG	
EVENT LOG	
ALARM LOG	
FAULTS	

STATISTICS	
CYCLES	
OPERATIONS	
OPERATING HOURS	
SOURCE 1	
SOURCE 2	
GENSET 1	
GENSET 2	
BREAKER	

SCHEDULER	
GENERAL PARAMETERS	
CUSTOM 1	

PARAMETERS	
NETWORK	
DISPLAY	
TIMERS	
I/O	
COMMUNICATION	
ALARMS	
PASSWORD	
WIZARD	



- Short press on this button to go back one level.
- Long press to access the menus.

To access to certain functions, you may be asked for a password.
By default, this is 1000.

NETWORK	
AUTODETECT.	
SETUP	
APPLICATION	
OP RANGE S1	
OP RANGE S2	

DISPLAY	
SCREEN	
DATE AND TIME	
OPTIONS	
CHANGE PRODUCT NAME	
SCREENSAVER TEXT	

TIMERS	
OPERATION	
GENSET SOURCE 1	
GENSET SOURCE 2	
TESTS ON LOAD	
TESTS OFF LOAD	

I/O	
INPUTS	
OUTPUTS	

COMMUNICATION	
MODBUS ADDRESS	
RS485 MODBUS	

ALARMS	
LOGICAL ALARMS CONFIG	
MAINTENANCE ALARMS CONFIG	
SYSTEM ALARMS CONFIG	

PASSWORD	
CHANGE OPERATOR PWD	
CHANGE CONFIG PWD	
CHANGE MAINTENANCE PWD	
BACK	

WIZARD	
LANGUAGE	
DATE AND TIME	
SOURCES	
INSTALLATION	
PRODUCT NAME	
COMMUNICATION RS485	

There are several events that can cause a Fault on the controller. Unlike the alarms, the faults are not user-selectable, they will always be considered and actions will take place as follows:

FAULT	DESCRIPTION (CAUSE)	ACTIONS	ACKNOWLEDGE / CLEARED	FAULT LOG	POP-UP	FAULT LED	OUTPUT
Unexpected Transfer	The controller receives a feedback/return from the switch without sending any order (auto or manu). Also if loss feedback of current position.	Mode stays the same. Controller will start retries if position is unknown. If a position is reached, no retry takes place.	Can also be cleared through display or through RST - Reset Fault input.	Yes	Yes, "Unexpected Transfer"	BLINKS (priority)	FLT - Fault active
Failed to Transfer	Position not reached after an order sent by controller (auto or manu) or loss of feedback of the new source after sending a transfer command.	Mode stays the same. Controller will start retries.	Automatically cleared if the requested position is reached or cleared through display or through RST - Reset Fault input.	Yes	Yes, "Failed to transfer"	BLINKS (priority)	FLT - Fault active
Max operation per minutes reached	If the controller performs 10 operations in less than 1 minute (by default) (automatic or controlled/manual)	Mode stays the same. During a timer, the controller will not do or allow any operation.	Automatic after the 1 minute (configurable through software) (value is dynamic).	Yes	Yes, "Max operations per minutes reached"	FIXED (non-critical)	FLT - Fault active
Max password attempts reached	User tries to enter a profile password more than X times set in the maintenance menu (by default 10 attempts)	Mode stays the same. Can't enter any password during X time set in the maintenance menu (by default 2 minutes)	Automatic after the set timeout (maintenance mode).	Yes	Yes, "Max number of tries reached, please wait: X s"	FIXED (non-critical)	FLT - Fault active
Genset Failstart	Controller tries to start a genset (as configured) and after the genset start delay, the genset doesn't start (controller doesn't see the source on)	Mode stays the same. Genset start relay remains active unless other source is available.	Automatic if genset starts or if source is set as Main/Utility.	Yes	Yes, "Engine fail to start"	BLINKS (priority)	FLT - Fault active
External fault	If an input is selected as FTE - External Fault and becomes active	Switch goes to position 0 /center-off directly without timers and the mode is set to Partial Inhibit (genset starts if needed).	Input mustn't be active and reset by user is requested (by RST- Reset Fault input or through display).	Yes	Yes, "External fault"	BLINKS (priority)	FLT - Fault active

For faults with pop-up, the pop-up will be cleared when fault will be cleared or by pressing any button on the front face of the controller. The total number of faults logged on the controller is dynamic, as the total number of "faults + alarms" is 100 (not including the events, which are 300) and uses a FIFO ordering.

To clear Faults through the display, it is possible inside the LOG/FAULTS menu with the option "PRESS OK TO CLEAR FAULTS", using the configurator profile password (1000). There is also a shortcut by holding the  button for 1.5s and validating on the pop-up that appears. If the fault is still active, it will be inside the log "in progress" but the fault LED and output will be off. If the faults are not active any more, they will be logged in the "history" log. This way to clear the fault will be automatically proposed by the controller through a pop-up:

