

Front of Cabinets

Tool List:

- T25 Torx driver



Day Two Side Panel
S**SPD2*
Installed

- Day Two Side Panel will fit between two S-Type cabinets or an S-Type and N-Type cabinet. The Side Panel would only be mounted to the S-Type Cabinet.
- Will *not* work on cabinets where the left-hand cabinet door is hinged on the right-hand side and the right-hand cabinet door is hinged on the left-hand side.

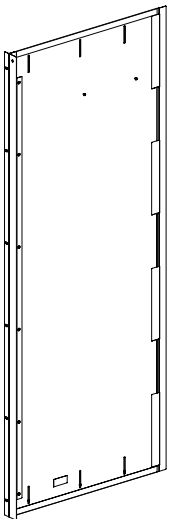

Front Panel
Qty. 1

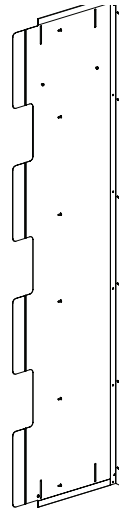

Rear Panel
Qty. 1

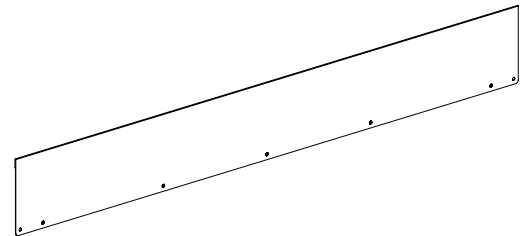

Filler Panel
Qty. 2

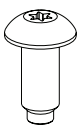

M5x0.8 x 12mm
Button Head Torx Screw
Qty: 18



M5x0.8 x 8mm
Button Head Serrated Torx Screw
Qty: 10



M6x1 x 12mm
Button Head Torx Screw
Qty: 6

Prepare front of Cabinets for Installation of Front Panel

- Open Front Door of right-side Cabinet to approximately 90° and pull down Compression Sleeve at top door hinge.
- Pull Single Hinge Door away from cabinet so that Top Hinge Screw fits through cut-out of door.
- Lift bottom of door off Bottom Hinge Pin
- Open Front Door of left-side Cabinet to approximately 90°.

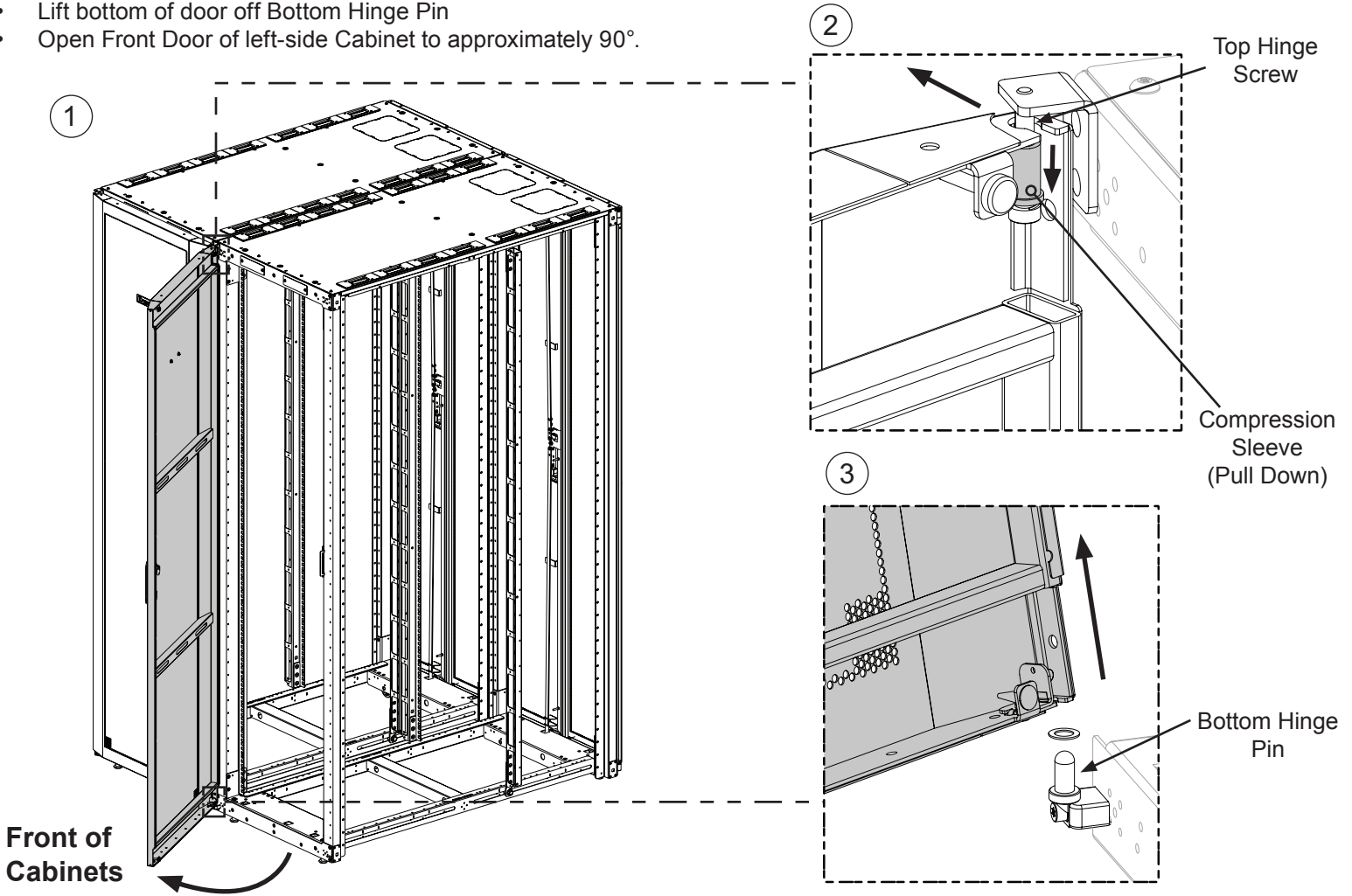

4

Open the Front Door of left-side Cabinet.
*It is not necessary to remove
the Front Door of left-side Cabinet.*

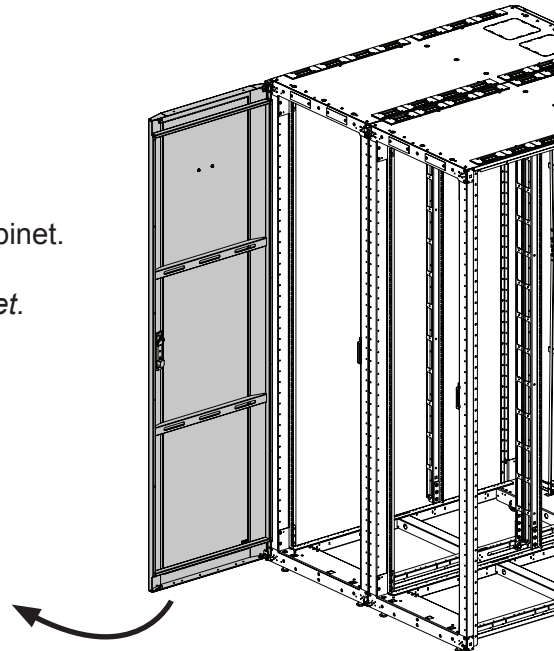

Install Front Panel

- Slide the Day Two Front Panel through the gap between the two cabinet post until the flanges contact the Cabinet Post.
- Secure Day Two Front Panel to Cabinet Posts with M5x0.8 x 12mm Button Head Torx screws through the front of Cabinet post and M6x1 x 12mm Button Head Torx screws through the side of the Cabinet post.
- Re-install Right-side Door.

1

Diamond cut-out in the Panel should be at the top of the cabinets.

Note: The Panel attaches to the inside of the frame on the hinged side of the door. This is to avoid interference with the mounting screw heads when opening. In the case where the door is hinged on the opposite side, the panel can be rotated 180°.

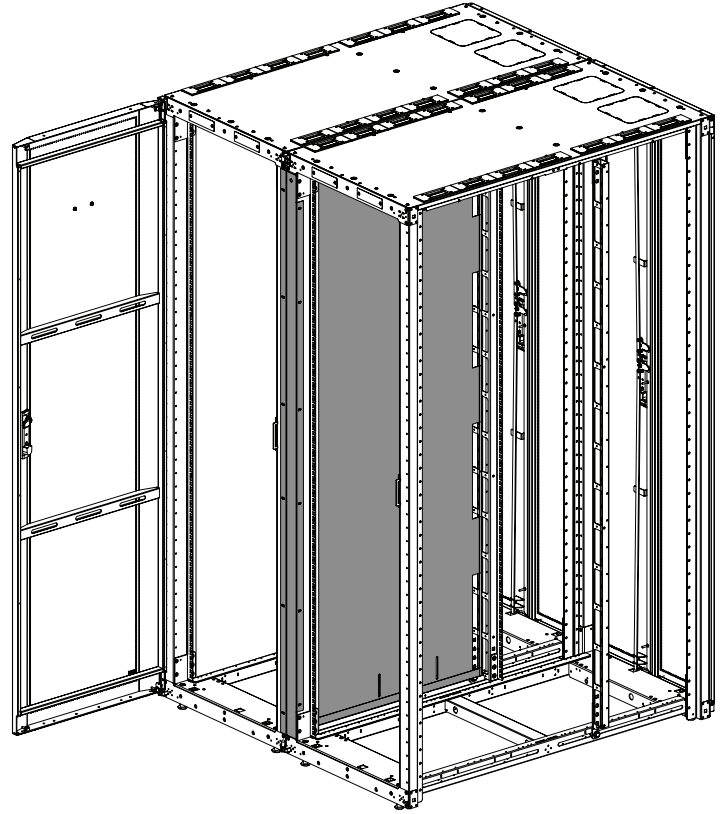
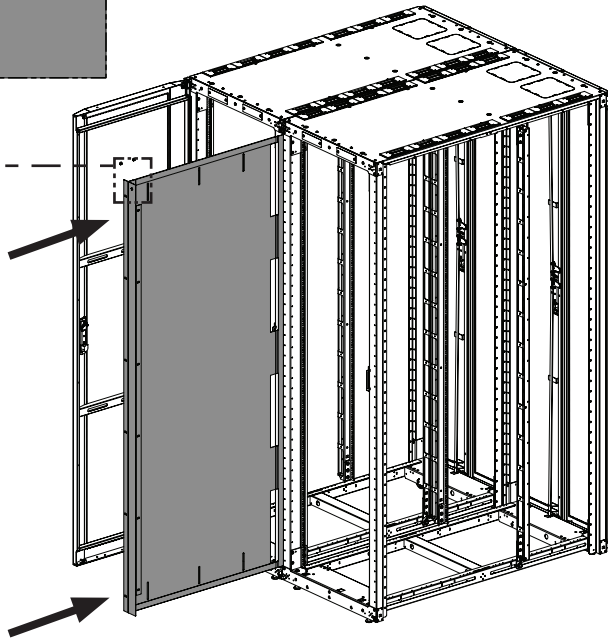
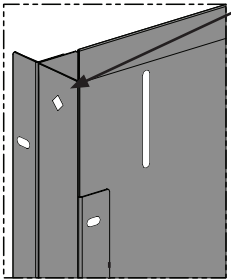

2

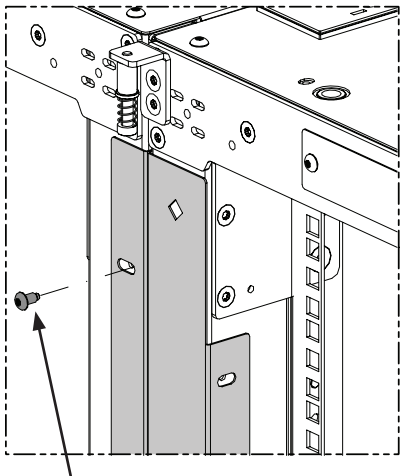

M5x0.8 x 12mm
Button Head Torx Screw

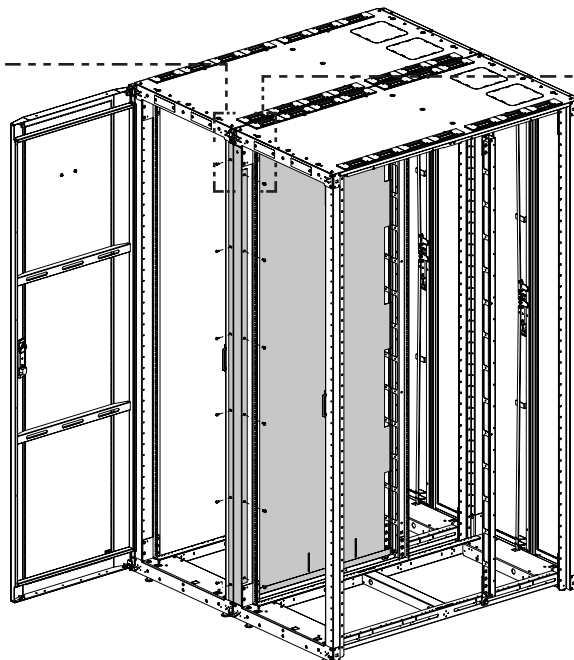

3

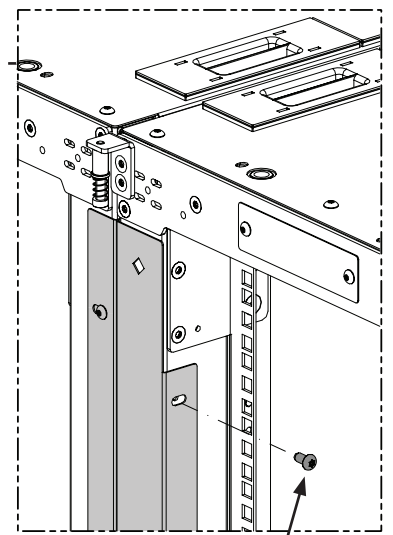

M6x1 x 12mm
Button Head Torx Screw

For Technical Support: www.panduit.com/resources/install_maintain.asp

Prepare rear of Cabinets for Installation of Rear Panel

- Open Rear Split Doors to approximately 90°.
- Remove the left-side Split Door from the right-side cabinet by lifting up and away from Cabinet frame.
- Remove the right-side Split Door from the left-side cabinet by lifting up and away from Cabinet frame.

Remove left-side Split Door from the right-side cabinet.

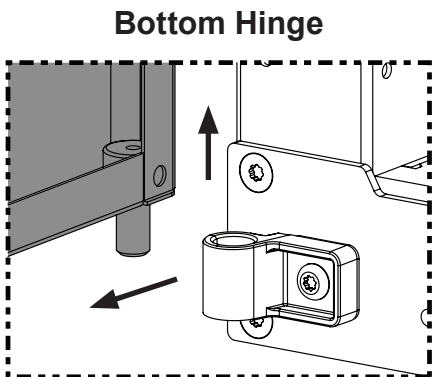
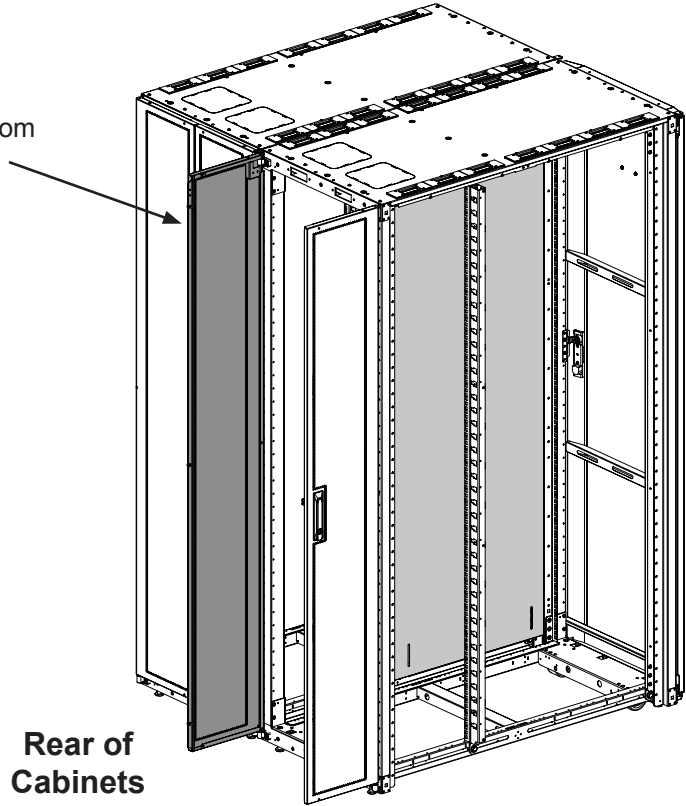
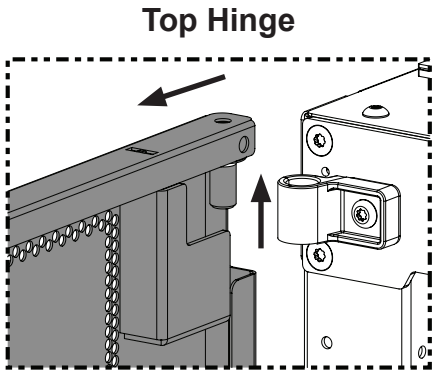

Remove right-side Split Door from the left-side cabinet.

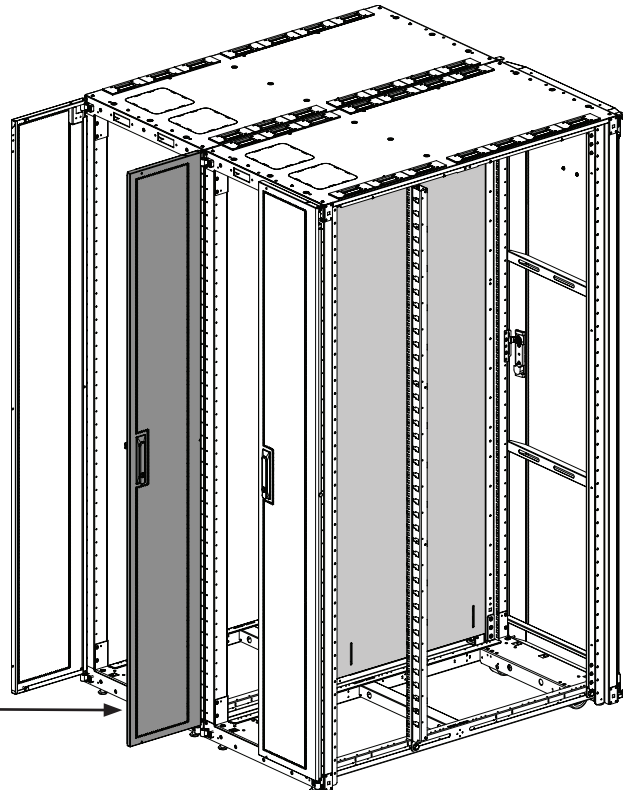

Install Rear Panel

- Slide the Rear Panel through the gap between the two cabinet post and insert the Tabs from the Rear Panel into the slots of the Front Panel.
- Secure Rear Panel to Cabinet Posts with M5x0.8 x 12mm Button Head Torx screws.
- Re-install Split Doors.

1

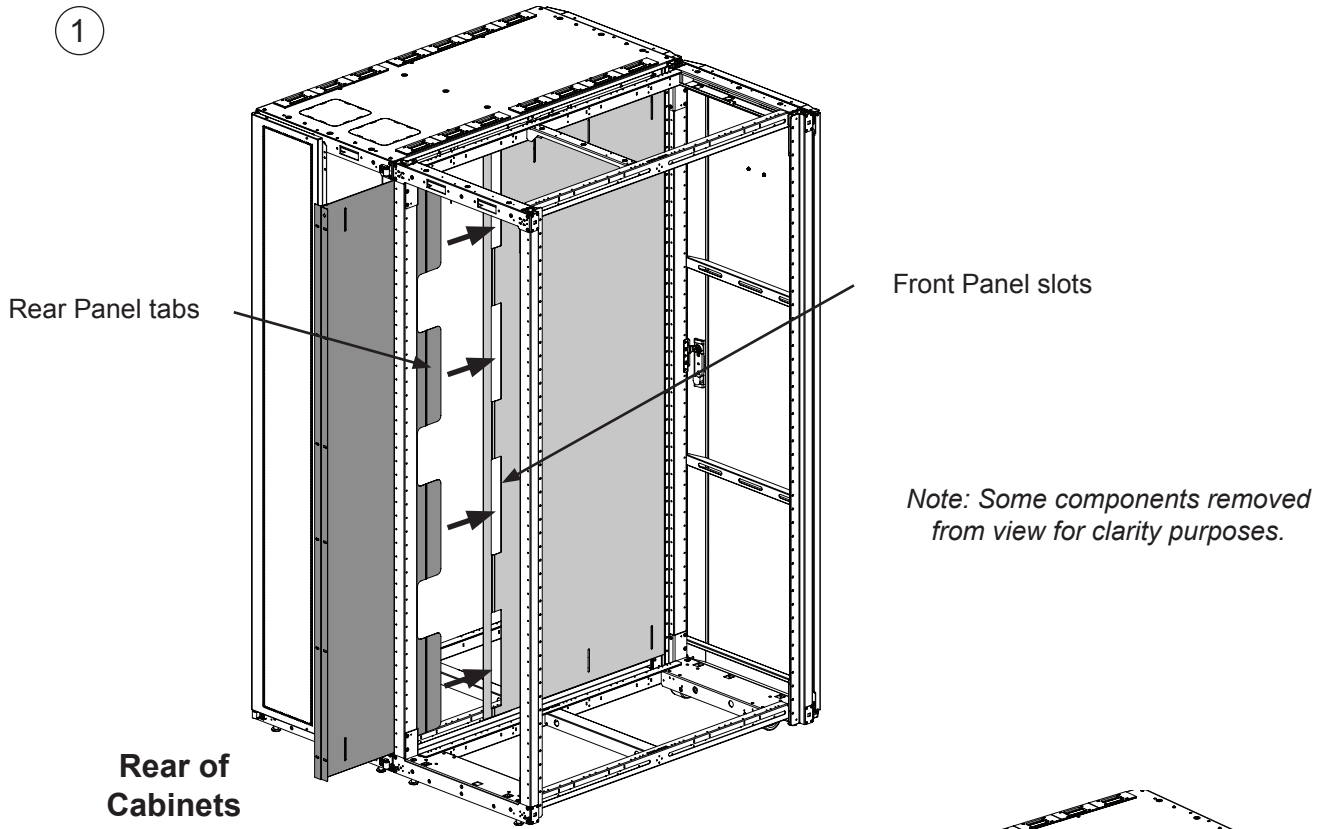

2

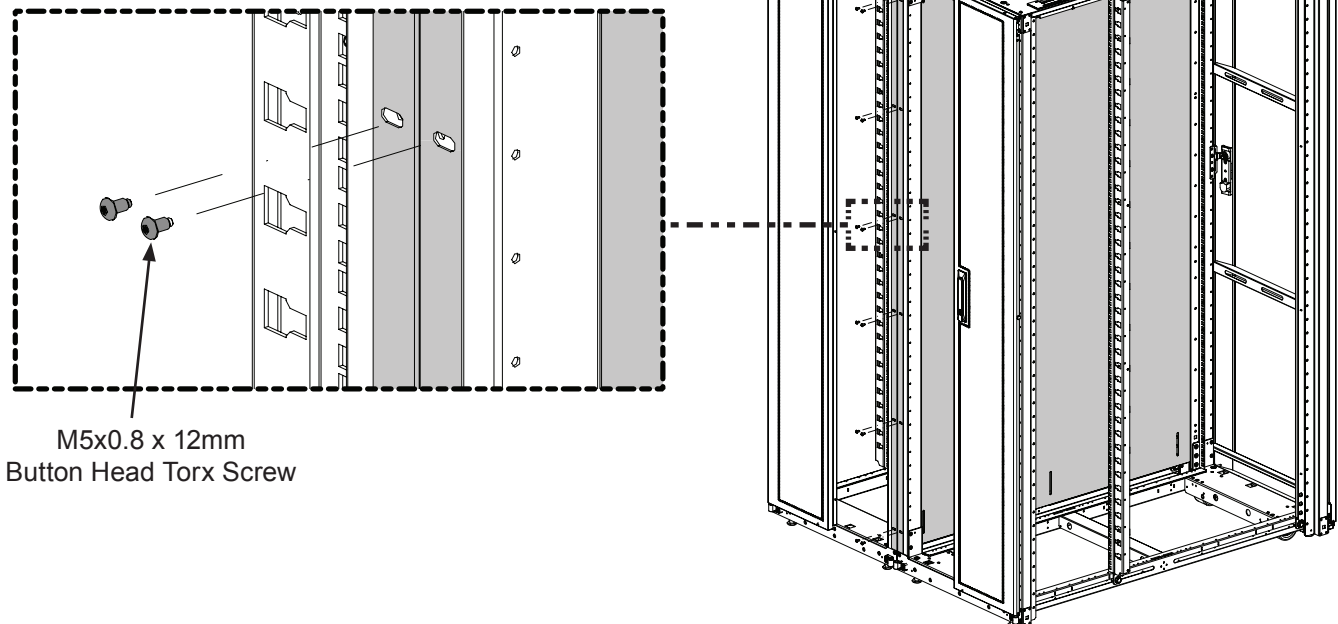

Install Filler Panels

- Slide the Filler Panels through the gap between the two cabinet post and position one each at top and bottom of Cabinet.
- Secure both Filler Panels from back side of Side Panel with M5x0.8 x 8mm Button Head Torx screws.
- Adjust Filler Panels up or down to close any air gaps.

1

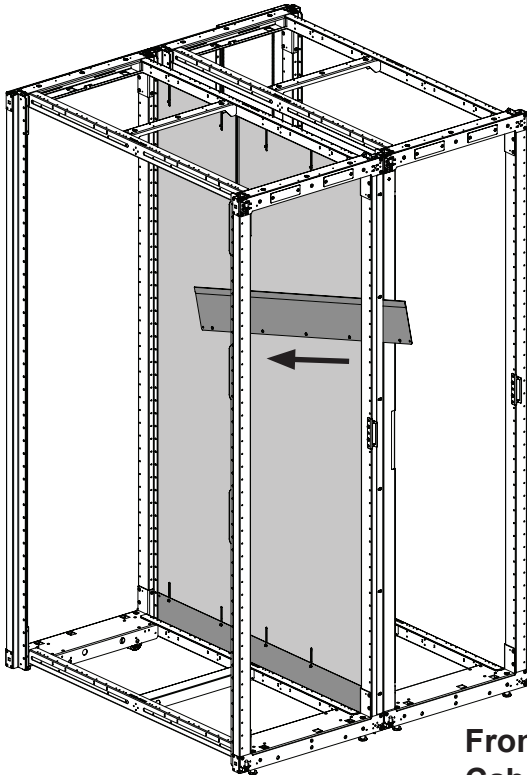

Front of Cabinets

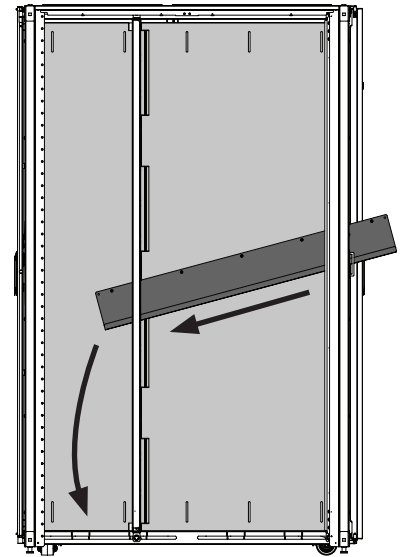

Bottom Panel
side view

2

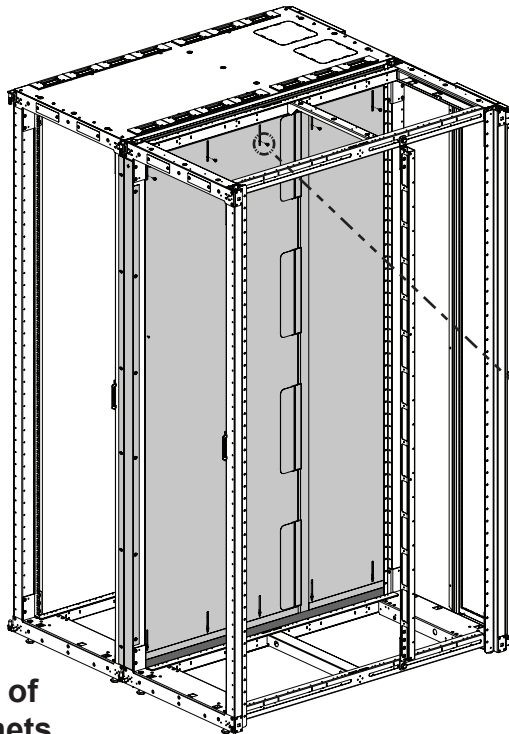

Front of Cabinets

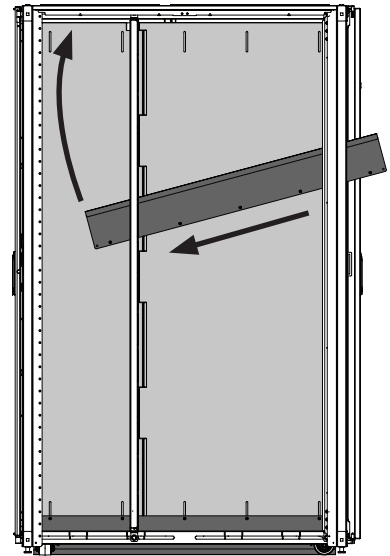

Top Panel
side view

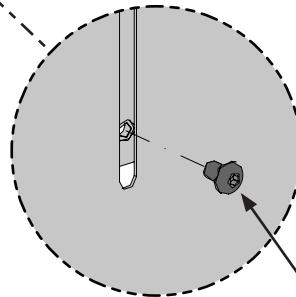

M5x0.8 x 8mm
Button Head Serrated Torx Screw

For Instructions in Local Languages
and Technical Support:

www.panduit.com/resources/install_maintain.asp

PANDUIT

www.panduit.com

E-mail:
techsupport@panduit.com

Phone:
866-405-6654