

1 Scellement des tiges & fixation du mât
 Install anchor J-Bolts in concrete foundation & fix the mast

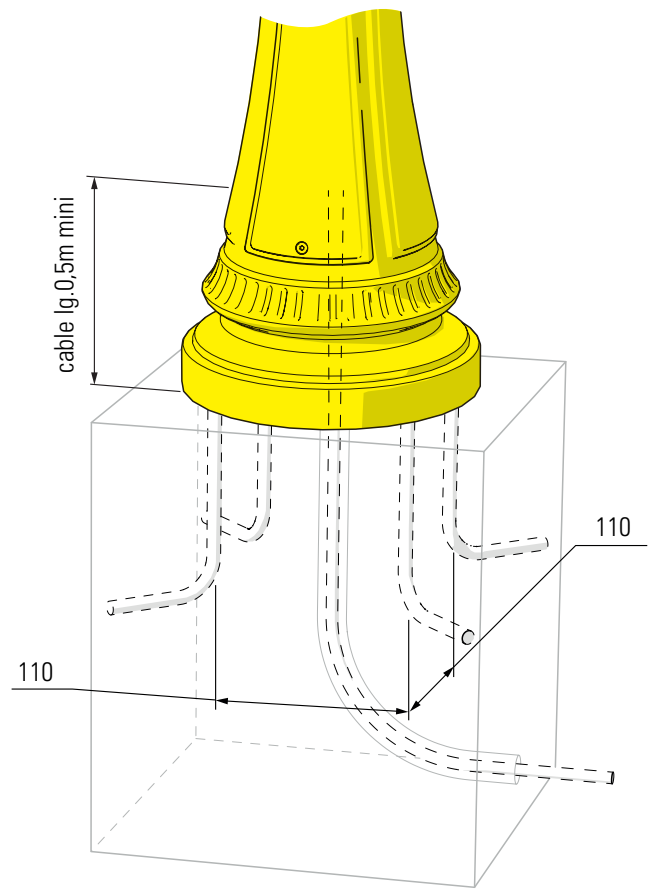

2 Montage de la tête sur le mât
 Mount the luminaire head on the mast

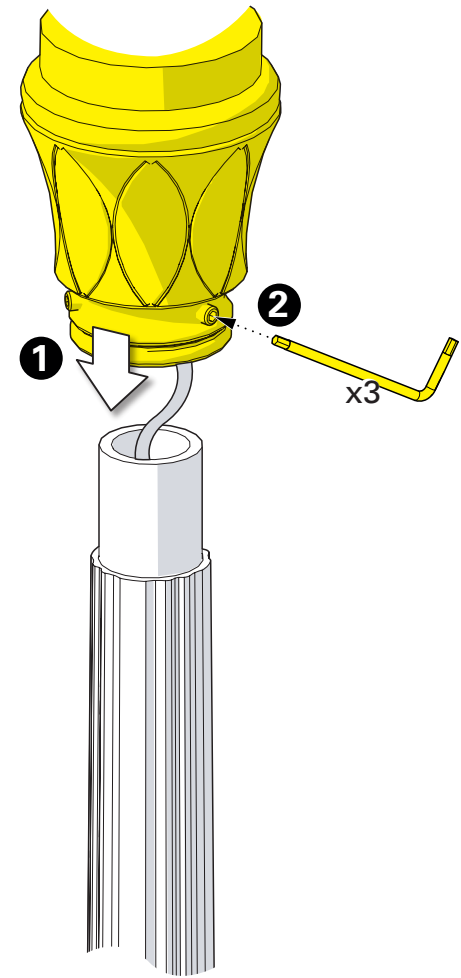

3 Raccordement électrique
 Connect electrical wires

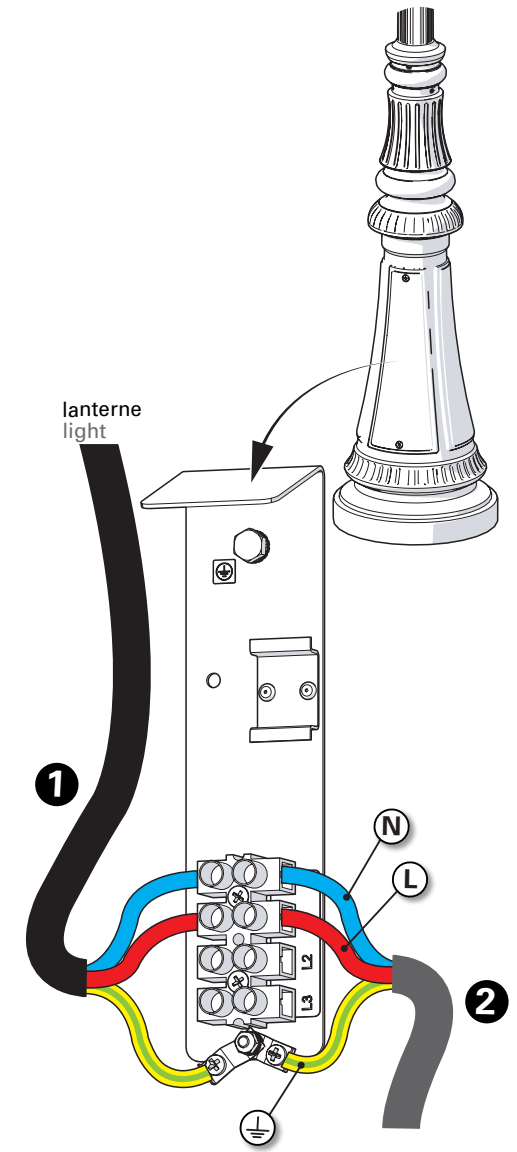

4 Installation des verres
Put in place glasses

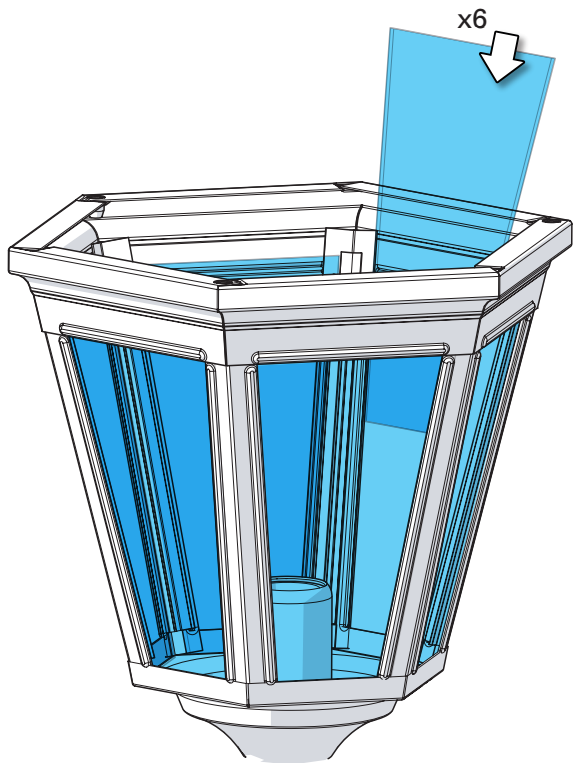

5 Montage de la lampe & du chapiteau
Put in place light-bulb & assemble the dome

