

THIS COPY IS PROVIDED ON A RESTRICTED BASIS AND IS NOT TO BE USED IN ANY WAY DETRIMENTAL TO THE INTERESTS OF PANDUIT CORP.

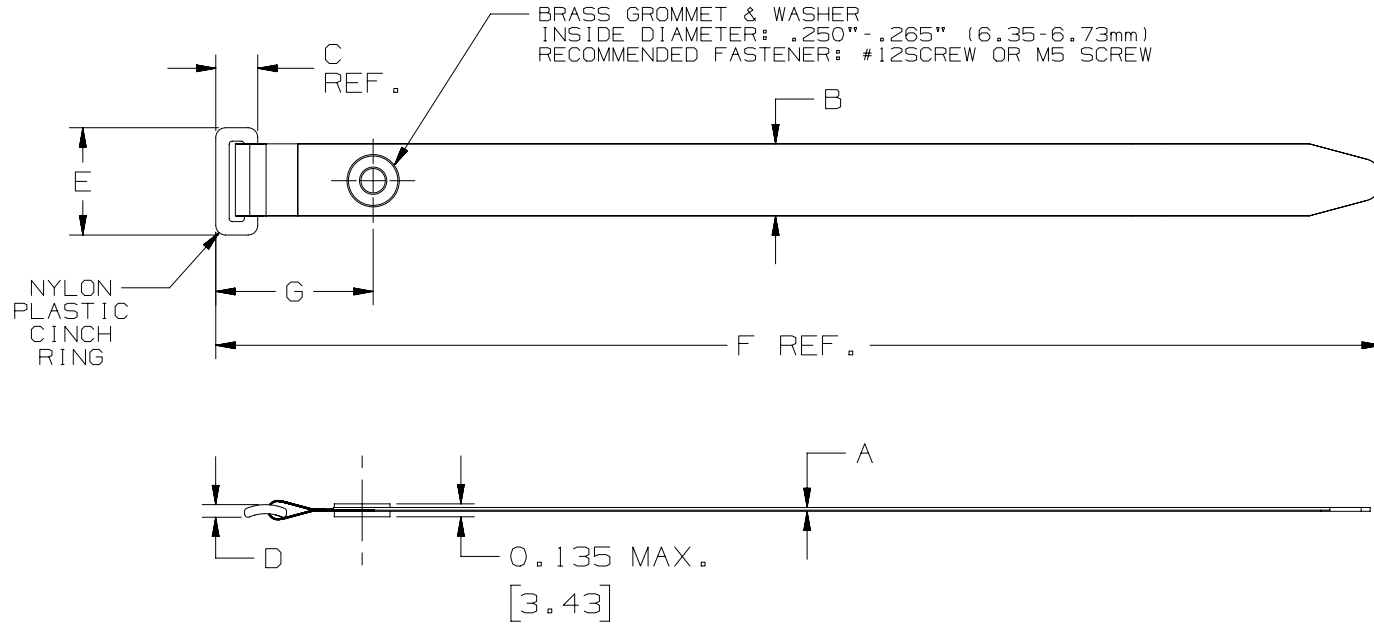

PANDUIT PART NO.	BUNDLE DIA.		A	B	C	D	E	F	G	MIN. LOOP TENSILE lbs. (N)	CROSS SECTION	APPROXIMATE WEIGHT lbs/100 PARTS (g)
	MIN. in (mm)	MAX. in (mm)	in (mm)	in (mm)	in (mm)	in (mm)	in (mm)	in (mm)	in (mm)			
UGCTCV1.5S	1.0 (25.4)	1.5 (38.1)	.100 (2.5)	.85 (21.6)	.45 (11.4)	.14 (3.6)	1.10 (27.9)	7.25 (184)	.88 (22.4)	50 (222)	STANDARD	.64 (291)

NOTES:

- 1) SEE CURRENT PRICE SHEET FOR PART NUMBER SUFFIX DESIGNATION FOR PACKAGE SIZE AND COLOR.
- 2) MINIMUM 2" OVERLAP REQUIRED TO ACHIEVE LOOP TENSILE RATING.

REV	DATE	BY	CHK	APR	DESCRIPTION	ECN	TITLE	MATERIAL:	DRAWING NUMBER:	SIZE	
03A	06-12-20	SAT	DWW	ML	INITIAL RELEASE	11K017BB-DC	TAK-TY HOOK & LOOP CABLE TIES ULTRA-CINCH HOOK & LOOP TIES CENTER MOUNT GROMMET, ALL MATERIALS ARE UL94V-2 RATED CUSTOMER DRAWING	<b>PANDUIT</b> WOVEN HOOK/LOOP NYLON	11K017BB-DC	A	
							ITEM REVISION NAME 11K017BB/03				
							DATASET FILE NAME 11K017BB/03				
							UNLESS OTHERWISE SPECIFIED, DIMENSIONAL TOLERANCES ARE: IN (mm) .x ± .25 (6.35)    .xxx ± .030 (7.62) .xx ± .125 (3.18)    ANGLES ± 1°				
							THIRD ANGLE PROJECTION				
							DRAWN BY SAT	DATE 06-12-20	CHK DWW	SCALE NONE	SHT 1 OF 1