

PanView iQ™ (PViQ™) Shielded Patch Panels

specifications

The shielded modular patch panel shall offer the choice of an installation that is fully intelligent or “intelligent ready” for future upgrades. The shielded patch panel design shall accommodate shielded copper RJ45 jack modules. The front of the panel shall include multi-colored LEDs located above each port that indicate the connectivity status, as well as multi-functional push buttons (when intelligence modules have been connected) for diagnostic and configuration navigation. The panel shall offer a “common” method for labeling in compliance with TIA/EIA 606-A labeling standards. The shielded modular patch panel shall be available in both flat and angled versions.



technical information

Dimensions:	Flat: 1.72"H x 19.0"W x 1.23"D (43.7mm x 482.6mm x 31.3mm), 1 RU Angled: 1.72"H x 19.0"W x 4.64"D (43.7mm x 482.6mm x 117.7mm), 1 RU
Weight:	Flat: 0.90 lbs. (0.408 kg) Angled: 1.25 lbs. (0.567 kg)
Mounting:	Mounts to standard EIA 19" or 23" racks (use extender brackets for 23" racks)
Packaging:	Includes mounting/grounding screws, installation instructions, and Ultimate ID® Label Covers

key features and benefits

Modular design	Accommodates intelligence modules that utilize no additional rack space (zero RU) for scalability and growth of network management in a low risk and cost-effective manner
Modular connectivity	Accepts all Mini-Com® STP Modules to reduce risk associated with cable maintenance and expansion, while offering greater choice of options
Simultaneous patching	Uses multi-colored LEDs to guide technicians through moves, adds, and changes, reducing time and improving accuracy of MAC activities
Local addressability	Accepts a multi-function interface unit to enable patch cord tracing and diagnostic navigation from front of panel, offering convenience, improved speed and accuracy of maintenance, and troubleshooting
Shielded grounding	Provides proper grounding using metal-to-metal contacts between shielded jack modules and the patch panel and bonding screws to make contacts between the panel and the rack, helping to protect network equipment and maximize uptime

applications

Panduit's PViQ™ System Hardware, which includes intelligent patch panels, modules, and cabling, seamlessly feeds information directly into the Physical Infrastructure Manager™ (PIM™) Software Platform to provide continuous real-time patch field monitoring and visibility of physical infrastructure connectivity for enhanced system reliability and security, and capacity management. Eliminating the need for additional rack space, the PViQ™ Patch Panels allow for direct installation of PViQ™ Intelligence Modules within the same rack unit profile. This approach gives IT Managers the option to phase installations

(installing passive connectivity now and upgrading to a fully managed system at a later time) and to quickly swap out modules for upgrades or repairs without disrupting cabling or data traffic through the panels. An interface unit at the center of the panel adds further built-in functionality such as patch cord tracing and maintenance operations, without the need for additional control equipment. PViQ™ Patch Panels are available in flat and angled solutions for UTP and STP copper connectivity, for both interconnect and cross-connect architectures.

www.panduit.com

PanView iQ™ Patch Panels

Modular, intelligent, blank 24-port	
Flat shielded:	PVQ-MIQPS24
Angled, shielded:	PVQ-MIQAPS24
Flat unshielded:	PVQ-MIQPU24
Angled, unshielded:	PVQ-MIQAPU24

PanView iQ™ Intelligence Modules

Panel manager (PM):	PVQ-PM
Expansion module (EM):	PVQ-EM

NOTE: PM requires PanView iQ™ Power Supply (not included).

PanView iQ™ Hardware Kits

Kit with (4) PanView iQ™ Patch Panels, (1) PanView iQ™ PM, (3) PanView iQ™ EMs, and accessories

Flat unshielded kit:	PVQ-MIQPS96F
Angled unshielded kit:	PVQ-MIQPS96A

NOTE: PM requires PanView iQ™ Power Supply (not included).

PanView iQ™ Patch Panel Accessories

Transitional cover for angled panels (0 RU): PVQ-MIQAPCVR

PanView iQ™ Patch Cords

Interconnect – Basic	
Category 6 UTP:	PVQ-BIU6C3BU^^
Category 6 UTP:	PVQ-BIU6C1MBU^^^
Category 6 UTP:	PVQ-BIU6L1MBU^^^
Interconnect – Enhanced	
UTP 10Gig:	PVQ-EU6AC3BU^^
UTP metric:	PVQ-EU6AC1MBU^^^
STP 10Gig:	PVQ-ES6X3BU^^
STP metric:	PVQ-ES6X1MBU^^^
Cross-Connect	
Category 6 UTP:	PVUTPSPC*BBUY
UTP metric:	PVUTPSPC**MBBUY
STP 10Gig:	PVSTP6X***MB^
UTP 10Gig:	PVUTP6X***MB^

PanView iQ™ Power Supply

12 volt power supply	
(North America):	PVQ-PS12VDC-S
(Europe):	PVQ-PS12VDC-E
(UK):	PVQ-PS12VDC-U
(Japan):	PVQ-PS12VDC-J
(China):	PVQ-PS12VDC-C

PIM™ Software Platform and Modules

Base functionality module:	
module:	PIM-BASE
Connectivity management module:	
module:	PIM-CONNECT‡
Maintenance, support and warranty agreement:	
agreement:	PIM-CAMA
Software and documentation:	
documentation:	PIM-MEDIA

*Available in 3, 5, 7, 9, 14, or 20 feet.
 **Available in 1, 2, 3, 5, 7, or 10 meters.
 ***Available in 1, 2, 3, 5, or 10 meters.
 ^Available in BU (Blue), GR (Green), RD (Red), YL (Yellow), or BL (Black).
 ^^Available in 3, 5, 7, 10, 14, or 20 feet.
 Available in BU (Blue) or WH (White).
 ^^Available in 1, 2, 3, 5, or 10 meters.
 Available in BU (Blue) or WH (White).
 ‡To order this module, add the appropriate letter to the end of the part number, based on the size of the installation: -S (<50 racks); -M (50-199 racks); -L (200-399 racks); -X (400+ racks). For example, the part number for the Connectivity Management Module for 250 racks is PIM-CONNECT-L.

PanView iQ™ (PViQ™) Shielded Patch Panels

PanView iQ™ Test Data

Environmental Testing	
Operating Temperature (ambient)	0°C to 45°C (32°F to 113°F)
Operating Humidity	Up to 90%, non-condensing
Storage Temperature	-40°C to 70°C (-40°F to 158°F)
Storage Humidity	Up to 90%, non-condensing
Operating Altitude	-1000' to 10,000' (-305M to 3,048M)
Regulatory Compliance	
Designed to meet all international requirements as part of the PViQ system	USA, Canada, European Union (CE Mark), Japan, Australia/N.Z., Korea
Electromagnetic Compatibility	
Designed to meet all international requirements as part of the PViQ system	USA, Canada, European Union (CE Mark), Japan, Australia/N.Z., Korea FCC Part 15 Subpart B Class A limit; ICES-003; VCCI; AS/NZS CISPR 22; EN 55022 Class A limit; EN 55024; KN22
Safety Approvals	
Designed to meet all international requirements	USA, Canada, European Union (CE Mark), Japan, Australia/N.Z., Korea IEC 60950-1 CB Certificate, UL 60950-1; CAN/CSA c22.2 No. 60950-1; EN 60950-1/, KCC Mark

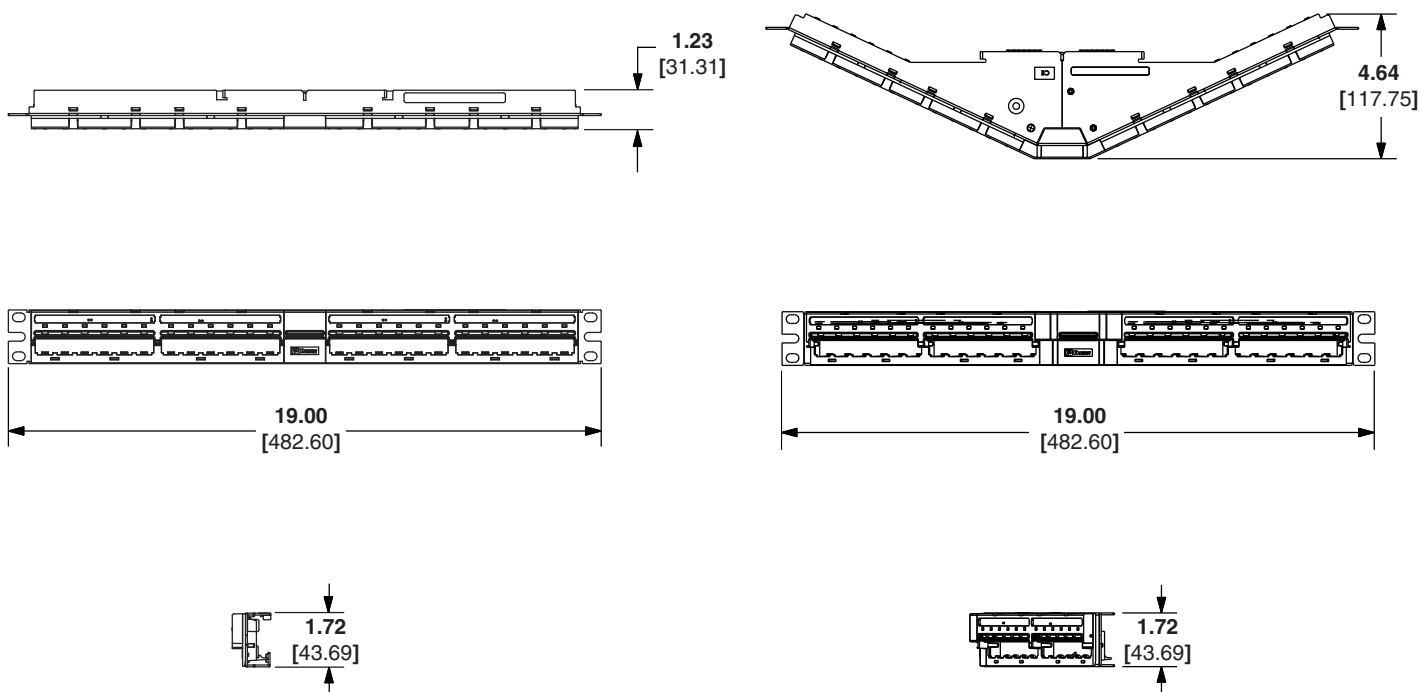

Dimensions are in inches. [Dimensions in brackets are metric].

WORLDWIDE SUBSIDIARIES AND SALES OFFICES

PANDUIT CANADA
Markham, Ontario
cs-cdn@panduit.com
Phone: 800.777.3300

PANDUIT EUROPE LTD.
London, UK
cs-emea@panduit.com
Phone: 44.20.8601.7200

PANDUIT SINGAPORE PTE. LTD.
Republic of Singapore
cs-ap@panduit.com
Phone: 65.6305.7575

PANDUIT JAPAN
Tokyo, Japan
cs-japan@panduit.com
Phone: 81.3.6863.6000

PANDUIT LATIN AMERICA
Guadalajara, Mexico
cs-la@panduit.com
Phone: 52.33.3777.6000

PANDUIT AUSTRALIA PTY. LTD.
Victoria, Australia
cs-aus@panduit.com
Phone: 61.3.9794.9020

For a copy of Panduit product warranties, log on to www.panduit.com/warranty

PANDUIT®

For more information
Visit us at www.panduit.com
Contact Customer Service by email: cs@panduit.com
or by phone: 800.777.3300

©2012 Panduit Corp.
ALL RIGHTS RESERVED.
PVSP76--WW-ENG
Replaces WW-PVSP30
7/2012