

10186202	DATA SHEET	
Gültig ab: 03.11.2020	EPIC® H-BE 48 CRIMPTERMINATION	

Description

- Inserts of the EPIC® H-BE series are regarded as classics in the industry and are ideal for use at higher voltages and currents.
- Crimp termination creates a vibration-proof connection, ensures maximum contact reliability between contact and wire and is suitable for automated assembly.
- Can be used in rail vehicles in conformity with standards (test of fire behavior according to DIN EN 45545-2:2016-02, requirement set R22 and R23, hazard levels HL1, HL2 and HL3).
- In the EPIC® H-BE series, inserts of different connection types within the same size can be combined as desired (screw, crimp, cage clamp or push-in).

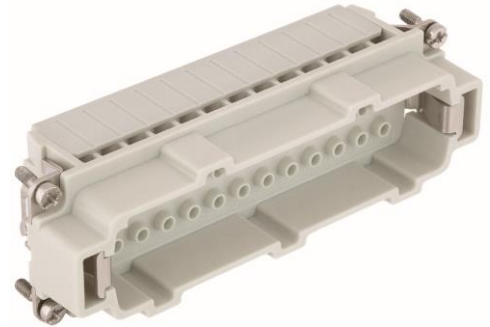

General Characteristics

Series	H-BE 48 for machined crimp contacts
Version	Male (Article No. 10187002) Female (Article No. 10187002)
Number of Contacts	48 + 2 PE
Termination Methods	Crimp termination: 0.14 – 4.0 mm ² (AWG 26–AWG 12)
Temperature Range	-40° to +125°C

Mechanical Characteristics

Cycle of mechanical operation	≥ 500
-------------------------------	-------

Electrical Characteristics

Rated Voltage, IEC	500 V
Rated Voltage, UL	600 V
Rated Voltage, CSA	600 V
Rated Impulse Voltage	6 kV
Rated Current, IEC	16 A
Rated Current, UL	16 A
Rated Current, CSA	16 A
Contact Resistance	≤ 5 mOhm
Degree of Soiling	3

Materials and Surfaces

Contacts	Copper alloy, hard silver-plated / hard gold-plated
Insulating Body	PC
Flammability Class according to UL 94	V0

Approvals

UL-Approval, E-File-Number	E75770
----------------------------	--------



Creator: STKU3/PDP Released: IVSE1/PDP	Document: DB10186202EN Version: 01	Page 1 of 3
---	---------------------------------------	-------------

10186202	DATA SHEET	
Gültig ab: 03.11.2020	EPIC® H-BE 48 CRIMPTERMINATION	

Standard

Safety Standards

IEC 61984, UL 1977, CSA-C22.2 No. 182.3

Railway applications

DIN EN 45545-2:2016-02

Fire protection on railway vehicles

Requirement sets R22 and R23,
Hazard level HL1, HL2 and HL3)

Railway applications

DIN EN 61373 Category 2

Rolling stock equipment

Shock and vibration tests

Technical Drawings

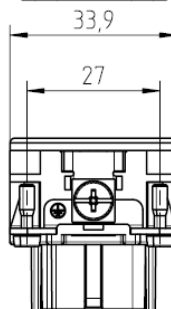
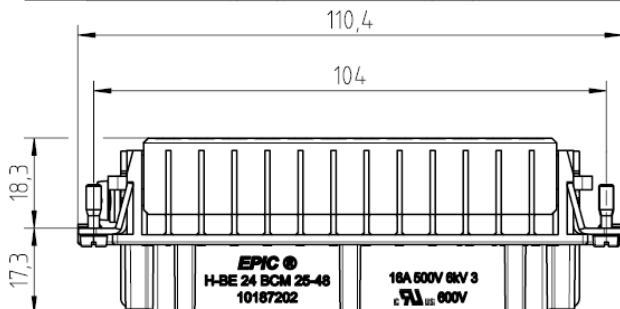
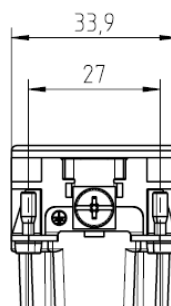
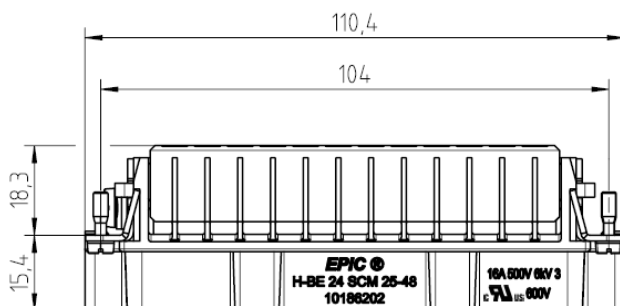
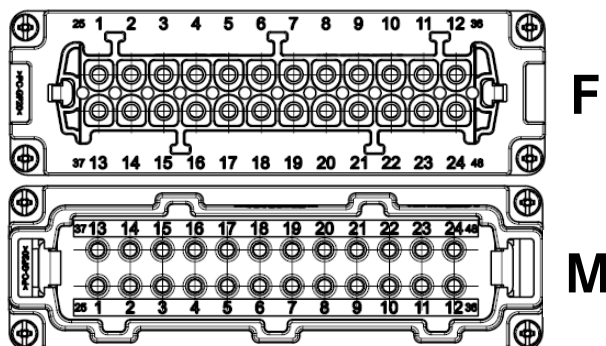
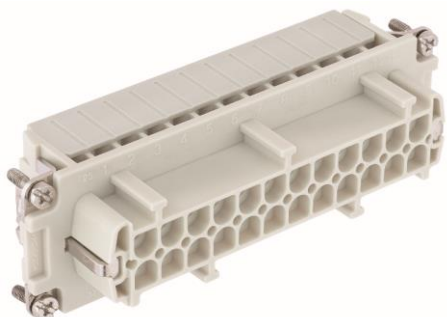

Maschinen- und Anlagenbau



Rail

Creator: STKU3/PDP
Released: IVSE1/PDP

Document: DB10186202EN
Version: 01

Page 2 of 3

10186202	DATA SHEET	
Gültig ab: 03.11.2020	EPIC[®] H-BE 48 CRIMPTERMINATION	



Robust



Temperature-resistant

Info

Multifunctional insert for versatile applications

Screw, crimp, cage clamp and Push-In version - freely combinable

The default PE-position is next to pin 1. PE-position can be changed to the other end of the connector if the change is made on both connectors (male and female)

Application range

Mechanical engineering; Light & sound technology; Plastics industry, Railway applications / vehicle construction

Remark

Photographs are not to scale and do not represent detailed images of the respective products.

Creator: STKU3/PDP Released: IVSE1/PDP	Document: DB10186202EN Version: 01	Page 3 of 3
---	---------------------------------------	-------------