

LXM32M

Profibus DP-V1 Module

Fieldbus manual

05/2018

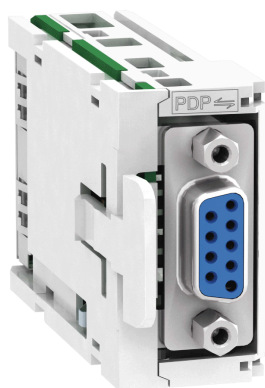

The information provided in this documentation contains general descriptions and/or technical characteristics of the performance of the products contained herein. This documentation is not intended as a substitute for and is not to be used for determining suitability or reliability of these products for specific user applications. It is the duty of any such user or integrator to perform the appropriate and complete risk analysis, evaluation and testing of the products with respect to the relevant specific application or use thereof. Neither Schneider Electric nor any of its affiliates or subsidiaries shall be responsible or liable for misuse of the information contained herein. If you have any suggestions for improvements or amendments or have found errors in this publication, please notify us.

You agree not to reproduce, other than for your own personal, noncommercial use, all or part of this document on any medium whatsoever without permission of Schneider Electric, given in writing. You also agree not to establish any hypertext links to this document or its content. Schneider Electric does not grant any right or license for the personal and noncommercial use of the document or its content, except for a non-exclusive license to consult it on an "as is" basis, at your own risk. All other rights are reserved.

All pertinent state, regional, and local safety regulations must be observed when installing and using this product. For reasons of safety and to help ensure compliance with documented system data, only the manufacturer should perform repairs to components.

When devices are used for applications with technical safety requirements, the relevant instructions must be followed.

Failure to use Schneider Electric software or approved software with our hardware products may result in injury, harm, or improper operating results.

Failure to observe this information can result in injury or equipment damage.

© 2018 Schneider Electric. All Rights Reserved.

Table of Contents



	Safety Information	5
	About the Book	7
Chapter 1	Introduction	11
	Fieldbus Devices on the Profibus Network	11
Chapter 2	Basics	13
	Conformance Classes	14
	Network Topology	15
	Data Structure	16
	Cyclic Communication - Overview	17
	Cyclic Communication - Structure of the Output Data	19
	Cyclic Communication - Structure of the Input Data	20
	Cyclic Communication - Parameter Channel	23
	Cyclic Communication - Handshake via the "Mode Toggle" Bit	25
	Acyclic Communication - Overview	26
	Acyclic Communication - Example: Reading a Parameter	29
	Controller as a Fieldbus Master	30
Chapter 3	Installation	31
	Installation of the Module	31
Chapter 4	Commissioning	33
	Preparation	34
	Settings with the Configuration Tool of the Master	36
Chapter 5	Operating States and Operating Modes	41
5.1	Operating States	42
	Indication of the Operating State via Fieldbus	43
	Changing the Operating State via Fieldbus	44
5.2	Operating Modes	45
	Indicating an Operating Mode	46
	Starting and Changing an Operating Mode	47
	Overview of Operating Modes	48
	Operating Mode Jog	49
	Operating Mode Electronic Gear	50
	Operating Mode Profile Torque	51
	Operating Mode Profile Velocity	52
	Operating Mode Profile Position	53
	Operating Mode Homing	54
	Operating Mode Motion Sequence	55
Chapter 6	Diagnostics and Troubleshooting	57
	Fieldbus Communication Error Diagnostics	58
	Fieldbus Test	59
	Fieldbus Status LEDs	60
	Error Messages	61
Glossary	65
Index	67



Important Information

NOTICE

Read these instructions carefully, and look at the equipment to become familiar with the device before trying to install, operate, service, or maintain it. The following special messages may appear throughout this documentation or on the equipment to warn of potential hazards or to call attention to information that clarifies or simplifies a procedure.



The addition of this symbol to a “Danger” or “Warning” safety label indicates that an electrical hazard exists which will result in personal injury if the instructions are not followed.



This is the safety alert symbol. It is used to alert you to potential personal injury hazards. Obey all safety messages that follow this symbol to avoid possible injury or death.

DANGER

DANGER indicates a hazardous situation which, if not avoided, **will result in** death or serious injury.

WARNING

WARNING indicates a hazardous situation which, if not avoided, **could result in** death or serious injury.

CAUTION

CAUTION indicates a hazardous situation which, if not avoided, **could result in** minor or moderate injury.

NOTICE

NOTICE is used to address practices not related to physical injury.

PLEASE NOTE

Electrical equipment should be installed, operated, serviced, and maintained only by qualified personnel. No responsibility is assumed by Schneider Electric for any consequences arising out of the use of this material.

A qualified person is one who has skills and knowledge related to the construction and operation of electrical equipment and its installation, and has received safety training to recognize and avoid the hazards involved.

QUALIFICATION OF PERSONNEL

Only appropriately trained persons who are familiar with and understand the contents of this manual and all other pertinent product documentation are authorized to work on and with this product. These persons must have sufficient technical training, knowledge and experience and be able to foresee and detect potential hazards that may be caused by using the product, by modifying the settings and by the mechanical, electrical and electronic equipment of the entire system in which the product is used.

The qualified person must be able to detect possible hazards that may arise from parameterization, modifying parameter values and generally from mechanical, electrical, or electronic equipment.

The qualified person must be familiar with the standards, provisions, and regulations for the prevention of industrial accidents, which they must observe when designing and implementing the system.

INTENDED USE

The products described or affected by this document are, along with software, accessories and options, servo-drive systems for three-phase servo motors. The products are intended for industrial use according to the instructions, directions, examples and safety information contained in the present user guide and other supporting documentation.

The product may only be used in compliance with all applicable safety regulations and directives, the specified requirements and the technical data.

Prior to using the products, you must perform a risk assessment in view of the planned application. Based on the results, the appropriate safety-related measures must be implemented.

Since the products are used as components in an overall machine or process, you must ensure the safety of persons by means of the design of this overall machine or process.

Operate the products only with the specified cables and accessories. Use only genuine accessories and spare parts.

Any use other than the use explicitly permitted as described herein is prohibited and may result in unanticipated hazards.

About the Book



At a Glance

Document Scope

The information provided in this manual supplements the product manual of the drive LXM32M.

The functions described in this manual are only intended for use with the associated product. You must read and understand the appropriate product manual.

Validity Note

This manual applies to the module Profinet DP-V1 for the product LXM32M, module identification PDP.

For product compliance and environmental information (RoHS, REACH, PEP, EOLI, etc.), go to www.schneider-electric.com/green-premium.

The technical characteristics of the devices described in this document also appear online. To access this information online:

Step	Action
1	Go to the Schneider Electric home page www.schneider-electric.com .
2	In the Search box type the reference of a product or the name of a product range. <ul style="list-style-type: none">Do not include blank spaces in the reference or product range.To get information on grouping similar modules, use asterisks (*).
3	If you entered a reference, go to the Product Datasheets search results and click on the reference that interests you. If you entered the name of a product range, go to the Product Ranges search results and click on the product range that interests you.
4	If more than one reference appears in the Products search results, click on the reference that interests you.
5	Depending on the size of your screen, you may need to scroll down to see the data sheet.
6	To save or print a data sheet as a .pdf file, click Download XXX product datasheet .

The characteristics that are presented in this manual should be the same as those characteristics that appear online. In line with our policy of constant improvement, we may revise content over time to improve clarity and accuracy. If you see a difference between the manual and online information, use the online information as your reference.

Related Documents

Title of documentation	Reference number
LXM32M - Profibus DP-V1 module - Fieldbus manual (this manual)	0198441113796 (eng) 0198441113797 (fre) 0198441113795 (ger)
Lexium 32M - Servo Drive - User Guide	0198441113767 (eng) 0198441113768 (fre) 0198441113766 (ger) 0198441113770 (spa) 0198441113769 (ita) 0198441113771 (chi)

You can download these technical publications and other technical information from our website at <http://www.schneider-electric.com/en/download>.

Product Related Information

WARNING

LOSS OF CONTROL

- The designer of any control scheme must consider the potential failure modes of control paths and, for certain critical control functions, provide a means to achieve a safe state during and after a path failure. Examples of critical control functions are emergency stop and overtravel stop, power outage and restart.
- Separate or redundant control paths must be provided for critical control functions.
- System control paths may include communication links. Consideration must be given to the implications of unanticipated transmission delays or failures of the link.
- Observe all accident prevention regulations and local safety guidelines.¹
- Each implementation of this equipment must be individually and thoroughly tested for proper operation before being placed into service.

Failure to follow these instructions can result in death, serious injury, or equipment damage.

¹ For additional information, refer to NEMA ICS 1.1 (latest edition), “Safety Guidelines for the Application, Installation, and Maintenance of Solid State Control” and to NEMA ICS 7.1 (latest edition), “Safety Standards for Construction and Guide for Selection, Installation and Operation of Adjustable-Speed Drive Systems” or their equivalent governing your particular location.

Terminology Derived from Standards

The technical terms, terminology, symbols and the corresponding descriptions in this manual, or that appear in or on the products themselves, are generally derived from the terms or definitions of international standards.

In the area of functional safety systems, drives and general automation, this may include, but is not limited to, terms such as *safety*, *safety function*, *safe state*, *fault*, *fault reset*, *malfunction*, *failure*, *error*, *error message*, *dangerous*, etc.

Among others, these standards include:

Standard	Description
EN 61131-2:2007	Programmable controllers, part 2: Equipment requirements and tests.
ISO 13849-1:2008	Safety of machinery: Safety related parts of control systems. General principles for design.
EN 61496-1:2013	Safety of machinery: Electro-sensitive protective equipment. Part 1: General requirements and tests.
ISO 12100:2010	Safety of machinery - General principles for design - Risk assessment and risk reduction
EN 60204-1:2006	Safety of machinery - Electrical equipment of machines - Part 1: General requirements
EN 1088:2008 ISO 14119:2013	Safety of machinery - Interlocking devices associated with guards - Principles for design and selection
ISO 13850:2006	Safety of machinery - Emergency stop - Principles for design
EN/IEC 62061:2005	Safety of machinery - Functional safety of safety-related electrical, electronic, and electronic programmable control systems
IEC 61508-1:2010	Functional safety of electrical/electronic/programmable electronic safety-related systems: General requirements.
IEC 61508-2:2010	Functional safety of electrical/electronic/programmable electronic safety-related systems: Requirements for electrical/electronic/programmable electronic safety-related systems.
IEC 61508-3:2010	Functional safety of electrical/electronic/programmable electronic safety-related systems: Software requirements.
IEC 61784-3:2008	Digital data communication for measurement and control: Functional safety field buses.
2006/42/EC	Machinery Directive
2014/30/EU	Electromagnetic Compatibility Directive
2014/35/EU	Low Voltage Directive

In addition, terms used in the present document may tangentially be used as they are derived from other standards such as:

Standard	Description
IEC 60034 series	Rotating electrical machines
IEC 61800 series	Adjustable speed electrical power drive systems
IEC 61158 series	Digital data communications for measurement and control – Fieldbus for use in industrial control systems

Finally, the term *zone of operation* may be used in conjunction with the description of specific hazards, and is defined as it is for a *hazard zone* or *danger zone* in the *Machinery Directive (2006/42/EC)* and *ISO 12100:2010*.

NOTE: The aforementioned standards may or may not apply to the specific products cited in the present documentation. For more information concerning the individual standards applicable to the products described herein, see the characteristics tables for those product references.

Chapter 1

Introduction

Fieldbus Devices on the Profibus Network

General

Profibus is a serial fieldbus which allows you to network products from different manufacturers without the need for special interface adaptation.

Different products with a Profibus interface can be operated in the same fieldbus segment. Profibus provides a common basis for interchanging commands and data between the network devices.

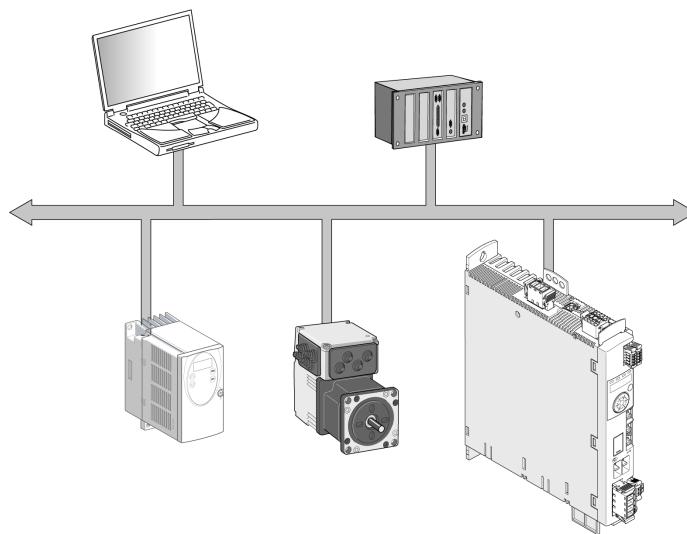

Functions

The following functions can be performed via the fieldbus:

- Reading and writing parameters
- Reading and writing inputs and outputs
- Diagnostics and monitoring functions

Networking the Product

The product is networked via a two-wire cable (RS-485 technology) and operates as a slave on the Profibus network.

Data is exchanged according to the master-slave model.

Chapter 2

Basics

The information contained in this chapter provides a general overview of the various protocols of the fieldbus as it applies to the equipment in the present document. It is not intended as a thorough treatment of the subject, nor is it a sufficient basis to design and deploy a fieldbus network in any given application.

The following information is intended to be consulted in an as needed, as is basis. Only appropriately trained persons who are familiar with and have the education and training necessary to understand the contents of this information, as well as all other pertinent product documentation, are authorized to work on and with this equipment.

What Is in This Chapter?

This chapter contains the following topics:

Topic	Page
Conformance Classes	14
Network Topology	15
Data Structure	16
Cyclic Communication - Overview	17
Cyclic Communication - Structure of the Output Data	19
Cyclic Communication - Structure of the Input Data	20
Cyclic Communication - Parameter Channel	23
Cyclic Communication - Handshake via the "Mode Toggle" Bit	25
Acyclic Communication - Overview	26
Acyclic Communication - Example: Reading a Parameter	29
Controller as a Fieldbus Master	30

Conformance Classes

Overview

The Profibus specification defines three Profibus versions that can be used for time-critical and complex communication tasks:

- Profibus FMS
- Profibus PA
- Profibus DP

Profibus FMS

Profibus FMS (FMS: Fieldbus Message Specification) is a universal, flexible solution for communication tasks in general automation technology. For example, Profibus FMS is used for communication between manufacturing cells.

Profibus PA

Profibus PA (PA: Process Automation) is used in process technology application, for example, process automation. In the case of networks with Profibus PA, data communication and power supply for sensors and actuators is possible via the bus. Therefore, Profibus PA can be used in explosive atmospheres (hazardous locations, Ex areas).

Profibus DP

Profibus DP (DP: Decentralized Periphery) is the fast Profibus version which is specially designed for communication in production processes and for building automation. Features of Profibus DP include simple networking of new products in the bus and high transmission rates.

Network Topology

Overview

A Profibus network consists of one or more masters (active bus devices) and slaves (passive bus devices). The bus devices are connected via a network cable.

Devices on the fieldbus network

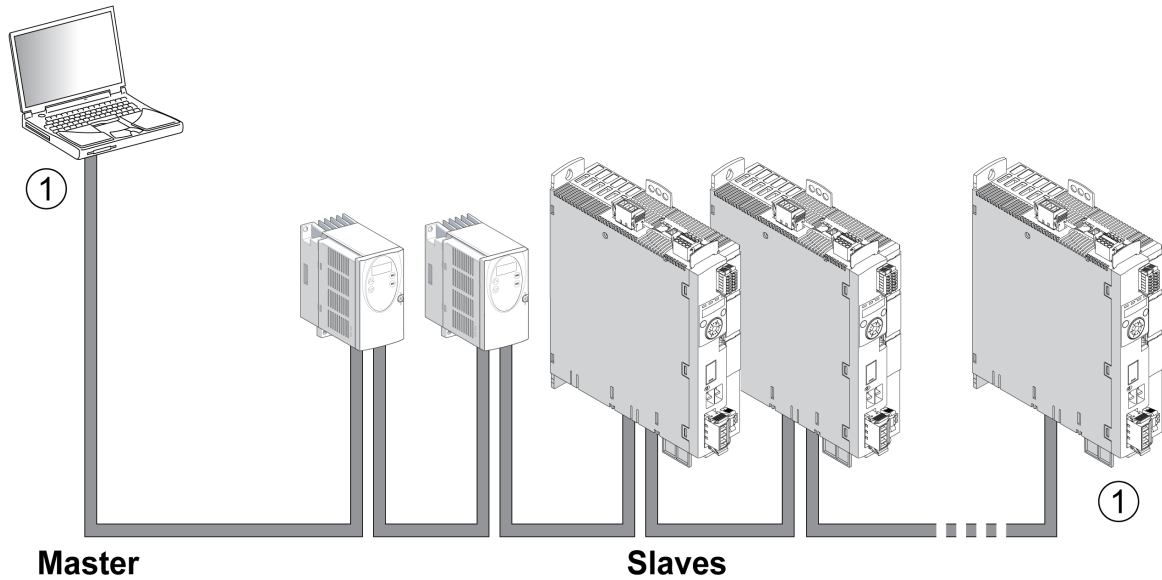

1 Both ends of the fieldbus must be terminated with a terminating resistor.

Master

The master controls the data traffic on the network. Examples of masters:

- Automation devices, for example, controllers
- PCs
- Programming devices

Slave

Slaves receive commands and supply data to the master. Examples of slaves:

- Input/output modules
- Drive systems
- Sensors and actuators

Data Structure

Overview

Byte, word and double word values are shown in hexadecimal notation. Hexadecimal values are indicated as such by means of an "h" behind the numerical value, for example, "31_h". Decimal values have no special identification. Note the different counting format of bits (right to left) and bytes (left to right).

General data structure from bit to double word

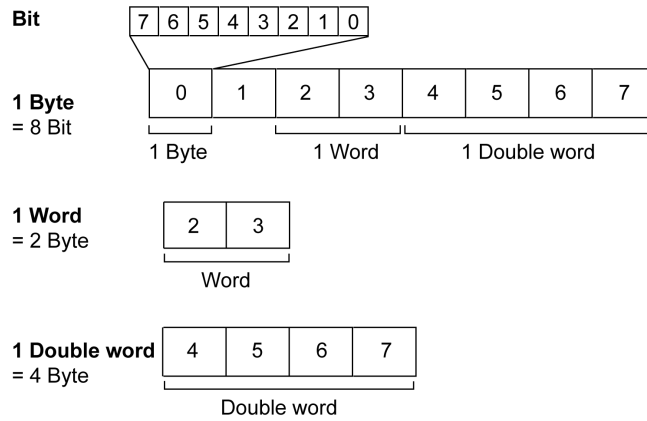

Used Byte Sequence: Big Endian Format

The bytes are transmitted in Big Endian format.

Cyclic Communication - Overview

Cyclic Communication

Profibus DP-V0 provides functionality for cyclic communication, station-specific, module-specific and channel-specific diagnostics and various alarm types for diagnostics.

Profibus DP-V0 fulfills the following tasks:

- Cyclic communication
- Station-specific diagnostics
- Module-specific diagnostics
- Channel-specific diagnostics

Master-Slave Relationship

The master cyclically writes transmit data to the slaves and reads the receive data provided by the slaves (MS0). Receive and transmit data for one slave are transmitted as one unit in one cycle.

Cyclic communication (MS0)

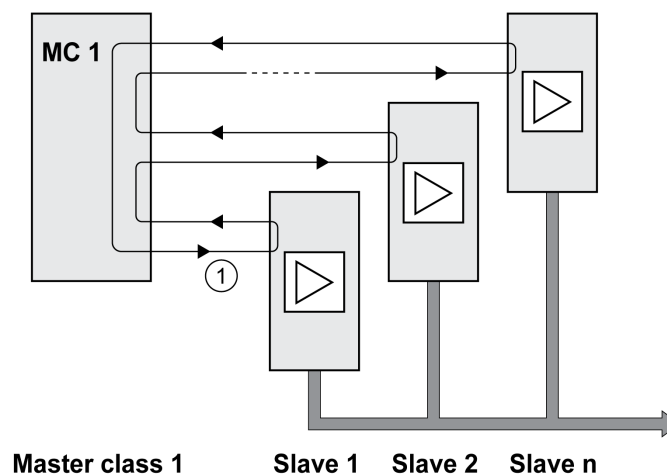

- 1 Cyclic communication starts at slave 1 and ends at slave n, the cycle restarts at slave 1.

Input Data and Output Data

With the output data, the master sends a command to the slave, for example, in order to start an operating mode, trigger a function, perform a movement or request status information. The slave executes the command and acknowledges it with a confirmation.

The exchange of data follows a fixed pattern:

- Output data to the slave: The master places a command in the output data memory. From there, it is transmitted to the slave and executed.
- Input data from slave: The slave acknowledges the command in the input data. If the command was successfully executed, the master receives an acknowledgement without an error message.

The master cannot send a new command unless it has received acknowledgement concerning the ongoing command. Acknowledgement information and error messages are included in the transmitted data in bit-coded form.

The master receives up-to-date input data from the slave during each cycle. The input data contains acknowledgement information concerning a transmitted command and status information.

The data of the cyclic communication comprise 2 parts:

- Process data channel
- Parameter channel (optional)

The selection of the drive profile determines whether or not the parameter channel is to be used.

Process Data Channel

The process data channel is used for realtime data exchange, for example the actual position or the actual velocity. Transmission is fast because the data is sent without additional administration data and data transmission acknowledgement from the recipient is not required.

The master can control the operating states of the slave via the process data channel, for example:

- Enabling and disabling the power stage
- Starting and terminating operating modes
- Starting and terminating movements
- Triggering a "Quick Stop" / resetting a "Quick Stop"
- Resetting an error message

Changing operating states and activating operating modes must be done separately. An operating mode can only be started if the operating state of the drive is **6** Operation Enabled.

NOTE: Changes of the operating mode and the acceleration values only become active when the motor is at a standstill. Acceleration values are accepted in the process data channel during movements, but the value is only applied during the next motion command. Other parameter values can be changed while the operating mode is active.

Parameter Channel

The master can request a parameter value from the slave or change a parameter value via the parameter channel. Each parameter can be uniquely addressed via the index and subindex.

Drive Profile

The product supports the following drive profiles:

- Profile 104: "Drive Profile Lexium 1" (vendor-specific)
- Profile 105: "Drive Profile Lexium 2" (vendor-specific)

Profile 104 "Drive Profile Lexium 1"	Profil 105: "Drive Profile Lexium 2"
Profile with 26 bytes	Profile with 10 bytes
Advanced functionality	Core functionality
With parameter channel (8 bytes)	Without parameter channel

Cyclic Communication - Structure of the Output Data

Overview

The output data is used to transmit requests from the master to the slave.

Output data "Drive Profile Lexium 1", profile 104

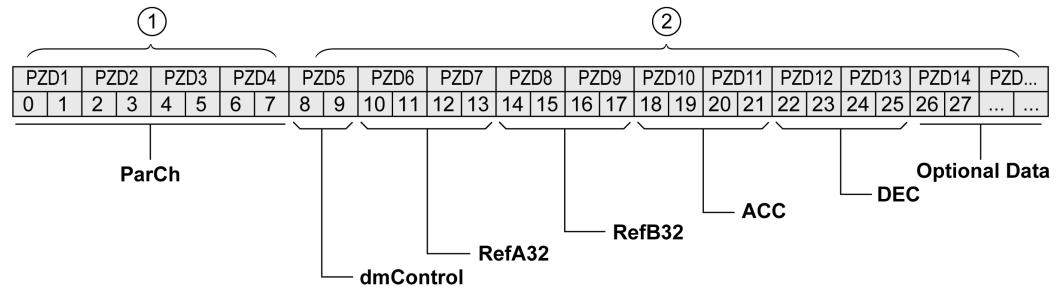

Output data "Drive Profile Lexium 2", profile 105

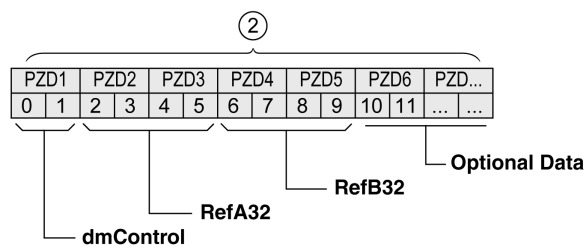

- 1 Parameter channel
- 2 Process data channel

Parameter Channel "ParCh"

Parameters can be read or written via "ParCh", see chapter Cyclic Communication - Parameter Channel (*see page 23*).

Word "dmControl"

The word "dmControl" is used to set the operating state and the operating mode.

See chapters Changing the Operating State via Fieldbus (*see page 44*) and Starting and Changing an Operating Mode (*see page 47*) for a detailed description of the bits.

Double Words "RefA32" and "RefB32"

The two double words "RefA32" and "RefB32" are used to set two values for the operating mode. The meaning depends on the operating mode; it is described in the chapters on the individual operating modes.

Double Words "ACC" and "DEC"

The two double words "ACC" and "DEC" are used to set the values for the acceleration ramp and the deceleration ramp. The acceleration ramp corresponds to the parameter `RAMP_v_acc`, the deceleration ramp corresponds to the parameter `RAMP_v_dec`.

Bytes "Optional Data"

"Optional Data" is used to append additional parameters to the profile that can be selected by the user (mapping). See chapter Settings with the Configuration Tool of the Master (*see page 36*) for additional information on mapping.

Cyclic Communication - Structure of the Input Data

Overview

The input data is used to transmit information from the slave to the master.

Input data "Drive Profile Lexium 1", profile 104

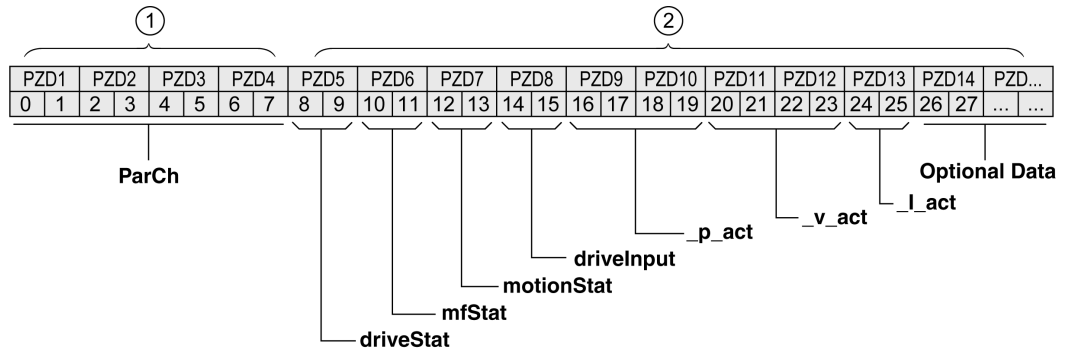

Input data "Drive Profile Lexium 2", profile 105

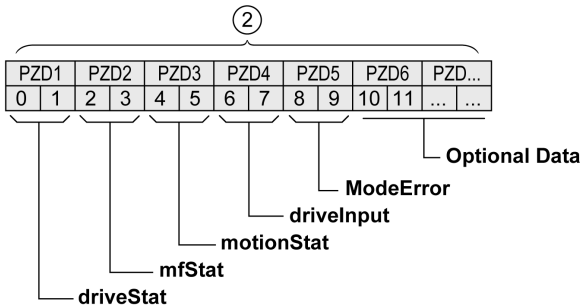

- 1 Parameter channel
- 2 Process data channel

Parameter Channel "ParCh"

Parameters can be read or written via "ParCh", see chapter Cyclic Communication - Parameter Channel (see page 23).

Word "driveStat"

The active operating state is indicated with the "driveStat" word.

For a detailed description of the bits, see chapter Indication of the Operating State via Fieldbus (see page 43).

Word "mfStat"

The word "mfStat" is used to indicate the active operating mode.

For a detailed description of the bits, see chapter Indicating an Operating Mode (see page 46).

Word "motionStat"

The word "motionStat" is used to provide information on the motor and profile generator.

Bit	Meaning
1	Positive limit switch triggered ⁽¹⁾
2	Negative limit switch triggered ⁽¹⁾
3 ... 5	Reserved
6	MOTZ: Motor at a standstill
7	MOTP: Motor movement in positive direction
8	MOTN: Motor movement in negative direction
9	Setting via parameter DS402intLim
10	Setting via parameter DPL_intLim
11	TAR0: Profile generator at standstill
12	DEC: Profile generator decelerates
13	ACC: Profile generator accelerates
14	CNST: Profile generator moves at constant velocity
15	Reserved
(1) With firmware version \geq V01.14	

Word "driveInput"

The word "driveInput" is used to indicate the status of the digital signal inputs.

Bit	Signal	Factory setting
0	DI0	Signal input function Freely Available
1	DI1	Signal input function Reference Switch (REF)
2	DI2	Signal input function Positive Limit Switch (LIMP)
3	DI3	Signal input function Negative Limit Switch (LIMN)
4	DI4	Signal input function Freely Available
5	DI5	Signal input function Freely Available
6 ... 7	-	Reserved
8	DI11 (module IOM1)	Signal input function Freely Available
9	DI12 (module IOM1)	Signal input function Freely Available
10	DI13 (module IOM1)	Signal input function Freely Available
11	DI14 (module IOM1)	Signal input function Freely Available
12 ... 15	-	Reserved

Double Word "_p_act"

The double word "_p_act" indicates the actual position. The value corresponds to the parameter `_p_act`.

Double Word "_v_act"

The double word "_v_act" can be parameterized. You can select the parameter `_v_act` (actual velocity) or the parameter `_n_act` (actual speed of rotation), see chapter Mapping for "_v_act" (*see page 36*).

Word "_I_act"

The word "_I_act" is used to provide information on the total motor current. The value corresponds to the parameter `_I_act`.

Word "ModeError"

The word "ModeError" is used to provide the vendor-specific error code that caused the ModeError to be set. The ModeError bit relates to MT-dependent parameters. The value corresponds to the parameter `_ModeError`.

Bytes “Optional Data”

“Optional Data” is used to append additional parameters to the profile that can be selected by the user (mapping). See chapter Settings with the Configuration Tool of the Master ([see page 36](#)) for additional information on mapping.

Cyclic Communication - Parameter Channel

Overview

The master can request a parameter value from the slave or change a parameter value via the parameter channel. Each parameter can be uniquely addressed via the index and subindex.

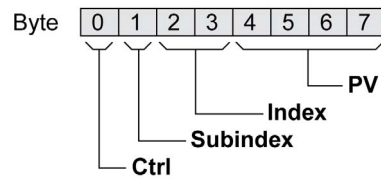

Byte "Ctrl"

Byte "Ctrl" contains the request to read or write a parameter.

The output data contains the information whether a parameter is to be read or written. The input data contains the information whether the read request or the write request were successful.

Output data:

Ctrl	Function
00 _h	No request
10 _h	Read request
20 _h	Write request (word)
30 _h	Write request (double word)

Input data:

Ctrl	Function
00 _h	Request not yet completed
10 _h	Read request or write request successfully completed (word)
20 _h	Read request or write request successfully completed (double word)
70 _h	Error message

Only one request can be processed at a time. The slave provides the response until the master sends a new request. If a response includes parameter values, the slave responds with the current value in the case of a repetition.

Read requests are only executed by the slave if the value changes from 00_h to 10_h. Write requests are only executed by the slave if the value changes from 00_h to 20_h or to 30_h.

Byte "Subindex"

The byte "Subindex" must be set to the value 00_h.

Word "Index"

The word "Index" contains the parameter address.

Double Word "PV"

The double word "PV" contains the parameter value.

In the case of a read request, the value in the output data has no significance. The input data contains the parameter value.

In the case of a write request, the output data contains the value to be written to the parameter. The input data contains the parameter value.

If a read request or a write request were not successful, the double word "PV" contains the error number of the error.

Example: Reading a Parameter

In the example, the program number of the product is read from the parameter `_prgNoDEV`. The parameter `_prgNoDEV` has the parameter address 258 (01_h 02_h).

The parameter value read has the decimal value 91200 which corresponds to 01_h 64_h 40_h.

Output data:

Ctrl	Subindex	Index	PV
10 _h	00 _h	01 _h 02 _h	00 _h 00 _h 00 _h 00 _h

Input data:

Ctrl	Subindex	Index	PV
20 _h	00 _h	01 _h 02 _h	00 _h 01 _h 64 _h 40 _h

Example: Writing of an Invalid Parameter

In this example, the value of a non-existent parameter is to be changed. The parameter has the parameter address 101 (00_h 65_h). The value of the parameters is to be changed to 222 (DE_h).

Before the slave can accept a new request, the value 00_h must first be transmitted in byte "Ctrl".

Since the slave cannot address the parameter, a synchronous error message is transmitted with the input data. Byte "Ctrl" is set to 70_h. Double word "PV" is set to the error number (error number 1101_h: Parameter does not exist).

Output data:

Ctrl	Subindex	Index	PV
30 _h	00 _h	00 _h 65 _h	00 _h 00 _h 00 _h DE _h

Input data:

Ctrl	Subindex	Index	PV
70 _h	00 _h	00 _h 65 _h	00 _h 00 _h 11 _h 01 _h

Cyclic Communication - Handshake via the "Mode Toggle" Bit

Mode Toggle

The "Drive Profile Lexium" uses synchronous communication. In the case of synchronous communication, the master waits for a response from the slave prior to new actions.

Synchronous communication is controlled by means of the appropriate bits in the output data and the input data:

- Output data: In the word "dmControl" by means of the bit "Mode Toggle"
- Input data: In the byte "mfStat" by means of the bit "ModeError" and the bit "Mode Toggle"

The bit "Mode Toggle" is effective with a rising edge and a falling edge.

Example 1: Positioning

The master starts a movement at point in time t_0 . At points in time t_1, t_2, \dots , the master verifies the responses from the slave. It waits for the end of the movement. The end of the movement is detected when bit "x_end" = 1.

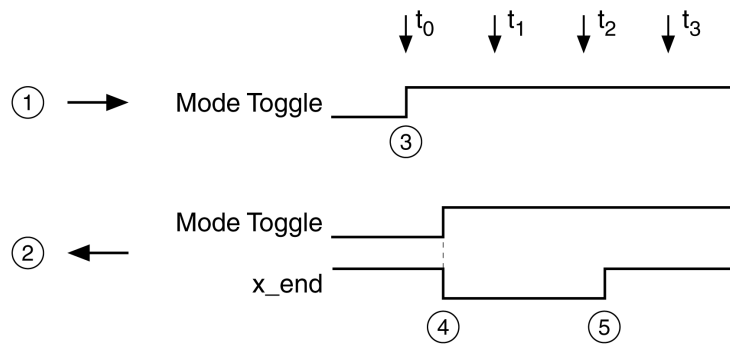

- 1 Output data
- 2 Input data
- 3 Master starts movement: Bit "Mode Toggle" = 1.
- 4 Slave reports "Movement running": Bit "Mode Toggle" = 1, bit "x_end" = 0.
- 5 Slave reports "Movement terminated": Bit "x_end" = 1.

Example 2: Short-Distance Movement

The master starts a short-distance movement at point in time t_0 . The duration is shorter than the request cycle of the master. At point in time t_1 the movement is terminated. Bit "x_end" does not allow the master to detect whether the movement is already terminated or has not yet been started. However, it can identify the state with the "Mode Toggle" bit.

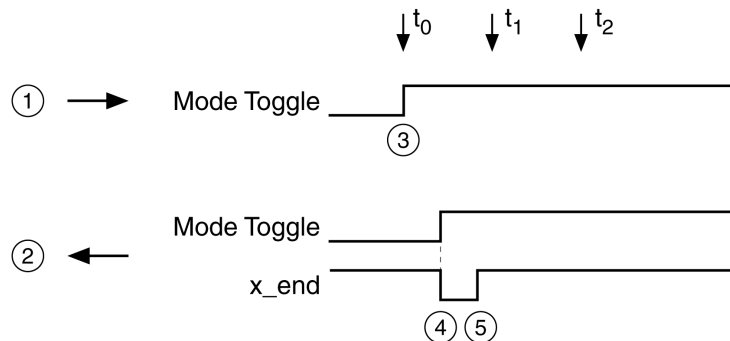

- 1 Output data
- 2 Input data
- 3 Master starts movement: Bit "Mode Toggle" = 1.
- 4 Slave reports "Movement running": Bit "Mode Toggle" = 1 and bit "x_end" = 0.
- 5 Slave reports "Movement terminated": Bit "x_end" = 1.

Acyclic Communication - Overview

Overview

In addition to cyclic communication, with Profibus DP-V1, the master and the slave can also communicate acyclically.

Acyclic communication enables the change of parameters during operation, but it is slower than the cyclic communication. Additionally, an acyclic communication with MS1 communication is used for acyclic error messages, see chapter DP-V1: Acyclic Alarm with MS1 Communication (*see page 62*).

Acyclic Communication - Parameter Channel

The slave supports acyclic data exchange as per Profibus specification for MS1 and MS2 communication. The following services are available for acyclic communication:

Service	Master class 1	Master class 2
READ	Read data set	Read data set
WRITE	Write data set	Write data set
INITIATE	-	Connect to master C2
ABORT	-	Terminate connection to master C2

Structure of acyclic communication:

- Master class 2 only: establish connection (INITIATE).
- Master sends WRITE Request with data (read parameter or write parameter).
- Slave confirms write request with WRITE Response.
- Master sends READ Request.
- Slave confirms read request with READ Response. Depending on the request, several READ Request / READ Response cycles without data transmission may be required before the slave can provide the data with a READ Response.
- Master class 2 only: termination of connection (ABORT).

When acyclic communication is finished, the master class 1 starts the next cycle.

Acyclic MS1 Communication

In the case of MS1 communication, a master class 1 is in charge of both cyclic and acyclic communication. Acyclic communication with a master class 1 (MC1)

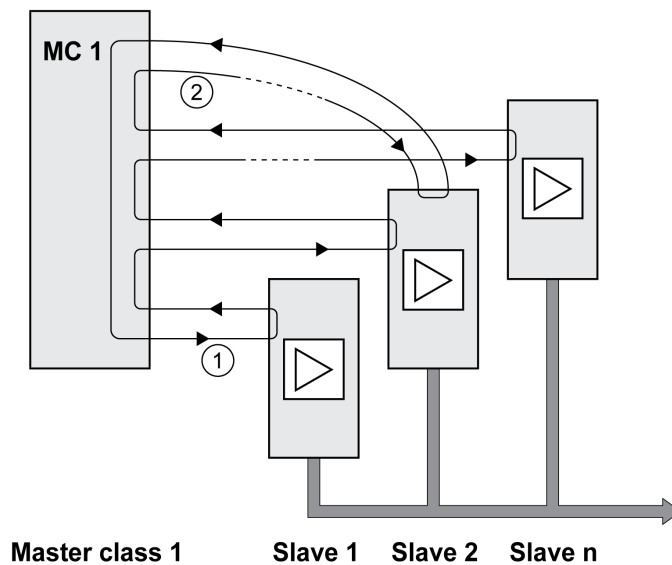

- 1 Cyclic communication starts at slave 1 and ends at slave n.
- 2 MC1 (master class 1) starts acyclic communication, with slave 2 in the example. After acyclic communication, the next cycle begins with slave 1.

Acyclic MS2 Communication

In the case of MS2 communication, a master class 1 is in charge of cyclic communication. The master class 1 can start an acyclic communication cycle after a cyclic communication cycle. When the master class 1 has completed communication, the token is passed on to the master class 2 (MC2) which starts acyclic communication. When acyclic communication of the master class 2 is finished, the token is passed back to the MC1 which starts a new cyclic communication cycle.

Acyclic communication with a master class 1 (MC1) and a master class 2 (MC2)

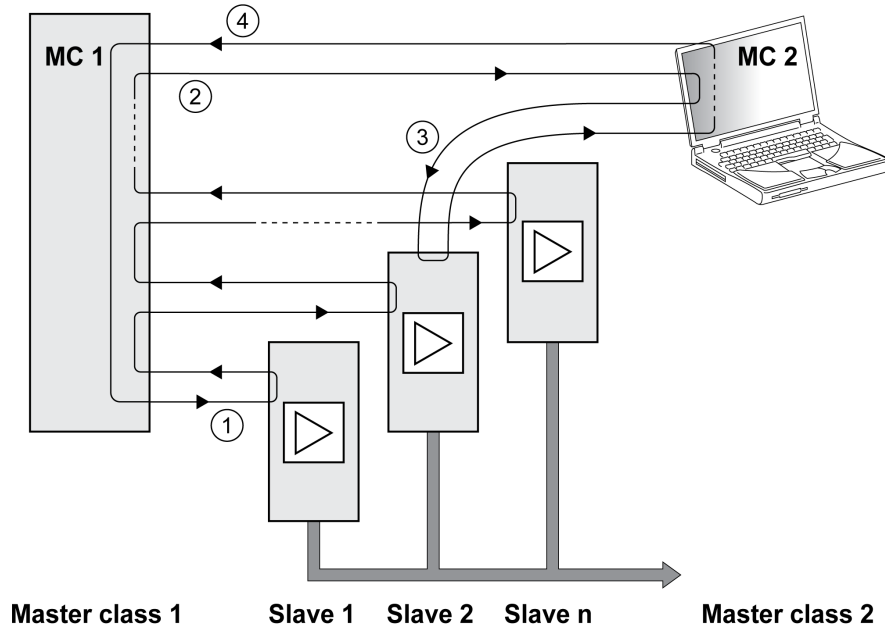

- 1 Cyclic communication starts at slave 1.
- 2 MC1 (master class 1) can start an acyclic communication cycle. The token is passed to MC2 (master class 2).
- 3 MC2 (master class 2) starts acyclic communication, with slave 2 in the example.
- 4 When the MC2 has terminated communication, the token is passed on to the MC1 (master class 1). MC1 (master class 1) begins the next cycle with slave 1.

Acyclic Communication: Elements

The following items are defined for acyclic communication:

	Data type	Value
REQUEST REFERENCE	Unsigned 8	00 _h : Reserved 01 _h ... FF _h
REQUEST ID	Unsigned 8	01 _h : Request Parameter 02 _h : Change Parameter
RESPONSE ID	Unsigned 8	Response (+) 00 _h : Reserved 01 _h : Request Parameter (+) 02 _h : Change Parameter (+) Response (-) 81 _h : Request Parameter (-) 82 _h : Change Parameter (-)
AXIS	Unsigned 8	01 _h
NO. OF PARAMETERS	Unsigned 8	01 _h ... 17 _h : 1 ... 23 DWORD (240 data bytes)
ATTRIBUTE	Unsigned 8	00 _h : Reserved 01 _h : Value
NO. OF ELEMENTS	Unsigned 8	00 _h : Special Function 01 _h ... EA _h : Quantity 1 ... 234
PARAMETER NUMBER	Unsigned 16	00 _h : Reserved 0001 _h ... FFFF _h : Parameter Index
SUBINDEX	Unsigned 16	0000 _h (Drive Profile Lexium)

	Data type	Value
FORMAT	Unsigned 8	42 _h : WORD 43 _h : DWORD 44 _h : ERROR
NO. OF VALUES	Unsigned 8	00 _h ... EA _h : Quantity 0 ... 234
ERROR NUMBER	Unsigned 16	0000 _h ... 0064 _h Error codes

Acyclic Communication - Example: Reading a Parameter

Sending WRITE Request

Administration data:

	WRITE Request	Description
Index	47	Index (Drive Profile Lexium: 47)
Length	10	10 bytes payload

Payload data:

Byte		Value	Description
0	REQUEST REFERENCE	01 _h	Reference number for parameter request
1	REQUEST ID	01 _h	Request Parameter
2	AXIS	01 _h	Axis 1
3	NO. OF PARAMETERS	01 _h	1 parameter is transmitted
4	ATTRIBUTE	10 _h	Parameter value (access)
5	NO. OF ELEMENTS	00 _h	Access to direct value (>0: sub-elements)
6, 7	PARAMETER NUMBER	0104 _h	Firmware version (1.2)
8, 9	SUBINDEX	0000 _h	Subindex: In drive profile Lexium 0

Sending READ Request

Administration data:

	READ Request	Description
Index	47	Index (Drive Profile Lexium: 47)
Length	10	10 bytes receive buffer

Receiving READ Response

Administration data:

	READ Response	Description
Index	47	Index (Drive Profile Lexium: 47)
Length	8	8 bytes payload

Payload data:

Byte		Value	Description
0	RESPONSE REFERENCE	01 _h	Mirrored reference number of parameter request
1	RESPONSE ID	01 _h	Positive response for requested parameter
2	AXIS	01 _h	Mirrored axis number (axis 1)
3	NO. OF PARAMETERS	01 _h	1 parameter is transmitted.
4	FORMAT	42 _h	Parameter format (WORD)
5	NO. OF VALUES	01 _h	Access to 1 value
6, 7	VALUE	xxxx _h	Value of the parameter

Controller as a Fieldbus Master

Description

The fieldbus master provides each connected slave with its own memory for output data and input data. Data can be exchanged between the controller memory and the fieldbus master via the peripheral equipment range or the process image range.

Fieldbus transmission and the application program read and write accesses to output data and input data are asynchronous. Therefore, it is possible that the fieldbus master reads the data from the controller memory before the controller was able to finish updating the data.

If a controller is used as the master device, the exchange of data can lead to inconsistent transmit data since fieldbus and controller cycles do not operate synchronously.

WARNING

INCONSISTENT CONTROL COMMANDS

- Ensure that the copy process does not create inconsistent data on the fieldbus.
- Copy data from high addresses first, toggle MT in the word "dmControl" last.

Failure to follow these instructions can result in death, serious injury, or equipment damage.

Data Exchange via the Peripheral Memory

In the case of data exchange via the peripheral memory, the data is consistent if MT in the word "dmControl" is entered last. The product ignores the transmitted data as long as this bit is equal to the MT in the word "mfStat".

Data Exchange via Process Image Memory

Data consistency during data exchange via the process image memory can only be achieved if there is no bus access to the data in the peripheral memory during the copy process between image and peripheral memory in the direction from a low to a high address.

Inconsistent data is generated if MT ("dmControl", bit 7) has already been transmitted via the bus before the slave has received the remaining valid data. As soon as MT is transmitted, the slave detects the state transition when verifying the bit and interprets this as a new command, which is executed immediately.

Chapter 3

Installation

Installation of the Module

Mechanical Installation

Electrostatic discharge (ESD) may permanently damage the module either immediately or over time.

<i>NOTICE</i>
EQUIPMENT DAMAGE DUE TO ESD <ul style="list-style-type: none">• Use suitable ESD measures (for example, ESD gloves) when handling the module.• Do not touch internal components. Failure to follow these instructions can result in equipment damage.

Install the module according to the instructions in the product manual of the drive.

D-Sub Connection

D9 D-SUB female connector with UNC 4-40 thread.

Tightening torque	Nm (lbin)	0.4 (3.54)
-------------------	-----------	------------

Cable Specifications

Shield:	Required, both ends grounded
Twisted Pair:	Required
PELV:	Required
Cable composition:	6*0.34 mm ² (6*AWG 22)
Max. cable length:	The maximum length depends on the baud rate and the signal propagation delay. The higher the baud rate, the shorter the bus cable needs to be.
Special features:	-

The maximum cable length depends on the baud rate and the signal propagation delay. The higher the baud rate, the shorter the bus cable needs to be.

Baud rate in kBaud	Maximum cable length in m (ft)
9.6	1200 (3937)
19.2	1200 (3937)
45.45	1200 (3937)
93.75	1200 (3937)
187.5	1000 (3280)
500	400 (1312)
1500	200 (656)
3000	100 (328)
6000	100 (328)
12000	100 (328)

- Use equipotential bonding conductors, see product manual.
- Use pre-assembled cables to reduce the risk of wiring errors.
- Verify that wiring, cables and connected interfaces meet the PELV requirements.

Terminating Resistor

Both ends of the bus system must be terminated with a terminating resistor. Use Profibus connectors with integrated terminating resistors at both ends of the bus system.

The diagram below shows the terminating resistor combination:

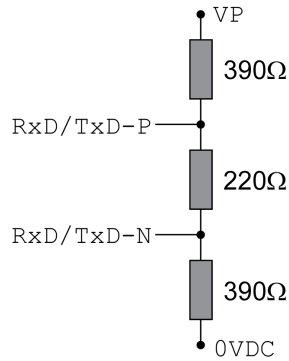

If the device is at the end of the network, use a Profibus connector with terminating resistor.

Pin Assignment

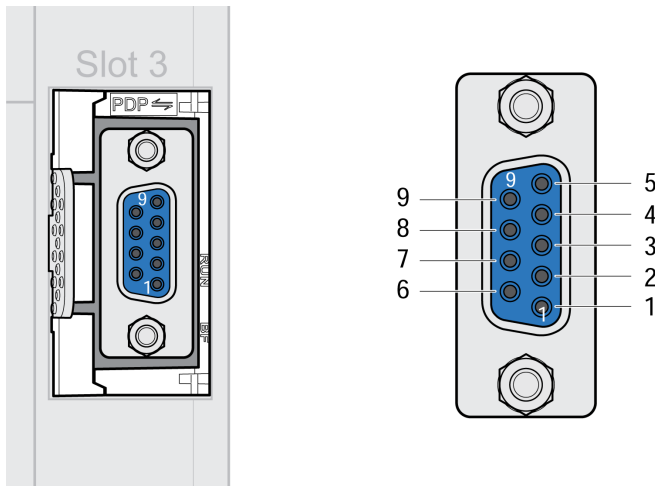

Pin	Signal	Meaning	Color
1 ... 2	-	Reserved	-
3	RxD/TxD-P	Data wire B	Red
4	RTS	Transmit request	-
5	0VDC	Reference potential	-
6	VP	Supply voltage	-
7	-	Reserved	-
8	RxD/TxD-N	Data wire A	Green
9	-	Reserved	-

Connecting Profibus

Use only approved Profibus connectors. The Profibus connectors are suitable for connecting the bus signal.

- Connect the Profibus signals.
- If the device is at the end of the network, use a Profibus connector with terminating resistor.
- Fasten the cables to the cable guide. The cable guide is not a strain relief.

Chapter 4

Commissioning

What Is in This Chapter?

This chapter contains the following topics:

Topic	Page
Preparation	34
Settings with the Configuration Tool of the Master	36

Preparation

This chapter describes how to commission the product.

The product is unable to detect an interruption of the network link if connection monitoring is not active.

WARNING

LOSS OF CONTROL

- Ensure that connection monitoring is enabled.
- Set the shortest, practical monitoring time cycles to detect communication interruptions as quickly as possible.

Failure to follow these instructions can result in death, serious injury, or equipment damage.

WARNING

UNINTENDED EQUIPMENT OPERATION

- Only start the system if there are no persons or obstructions in the zone of operation.
- Do not write values to reserved parameters.
- Do not write values to parameters unless you fully understand the function.
- Run initial tests without coupled loads.
- Verify correct word order for fieldbus communication.
- Do not establish a fieldbus connection unless you have fully understood the communication principles.

Failure to follow these instructions can result in death, serious injury, or equipment damage.

Required Components

The following is required for commissioning:

- Commissioning software “Lexium32 DTM Library”
http://www.schneider-electric.com/en/download/document/Lexium_DTM_Library/
- Fieldbus converter for the commissioning software for connection via the commissioning interface
- GSD file
<http://www.schneider-electric.com/en/download/document/SE120B9D.GSD/>
- Profibus master
- Product manual LXM32M and fieldbus manual LXM32M Profibus

GSD File

The specific features of a Profibus product are described in the Generic Station Description file (GSD file). The GSD file is provided by the manufacturer of the product and must be read using the configuration tool of the master.

The GSD file contains information on the operation of the product on the Profibus network.

- Manufacturer information
- Device class (Ident number)
- Supported baud rates
- Time intervals for monitoring times
- Settings of inputs and outputs

Ident Number

A master device uses the Ident number to identify the device class of the connected slave. The Ident number is a unique number assigned to each device class by the Profibus user organization.

Network Address

Each device on the network must be assigned with a unique address between 1 and 126. Slaves normally use the address range 3 ... 126. The master (normally address 0 ... 2) can communicate with each slave via this address.

After powering on the drive for the first time or after the factory settings have been restored, the drive must be configured with a unique address.

- Enter the network address. The network address is stored in the parameter `PBaddress` (`PbAD`).

It is also possible to set the network address by means of the Profibus DP-V0 service "Change Station Address" (`Set_Slave_Add`).

The transmission rate (baud rate) on the network is detected automatically. It must be the same for all devices on the network.

The transmission rate can be read via the parameter `_PBbaud` (`Pbbd`).

Settings with the Configuration Tool of the Master

GSD File

The GSD file must be read with the configuration tool of the master. The device is then known to the network.

In the Hardware catalog, select the device "LEXIUM32-PROFIBUS-DPV1" from the list.

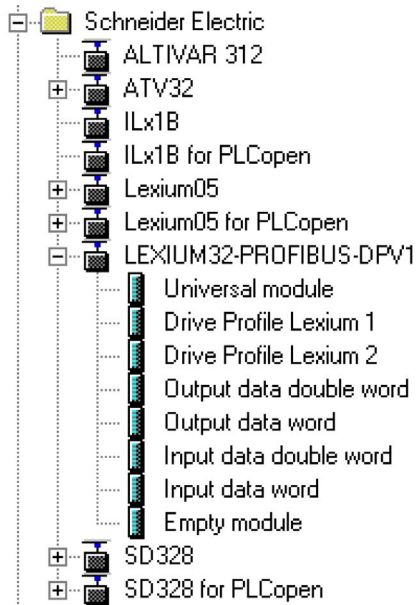

Selecting the Drive Profile

The configuration tool of the master lets you select the drive profile to be used.

In the Device overview, select the required drive profile ("Drive Profile Lexium 1" or "Drive Profile Lexium 2") in slot 1. See chapter Cyclic Communication - Overview ([see page 17](#)) for additional information on the drive profiles.

Slot	DP ID	Order Number / Designation	I Address	Q Address	Comment
1	195	Drive Profile Lexium 1	20..45	20..45	
2	0	Empty module			
3	0	Empty module			
4	0	Empty module			
5	0	Empty module			
6	0	Empty module			
7	0	Empty module			
8	0	Empty module			
9	0	Empty module			

Mapping for "_v_act"

In the drive profile "Drive Profile Lexium 1", the double word "_v_act" can be parameterized. In the properties of the drive profile "Drive Profile Lexium 1", you can select the parameter `_v_act` (actual velocity) or `_n_act` (actual speed of rotation).

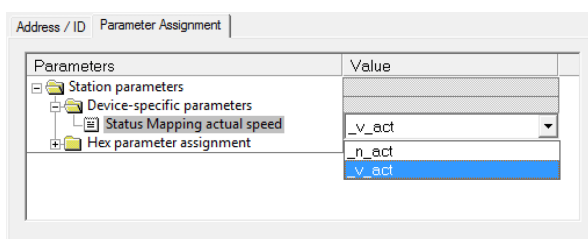

Setting for "Diagnostic interrupt"

The setting "Diagnostic interrupt" allows you to activate and deactivate the diagnostics function. By default, the diagnostics function is active.

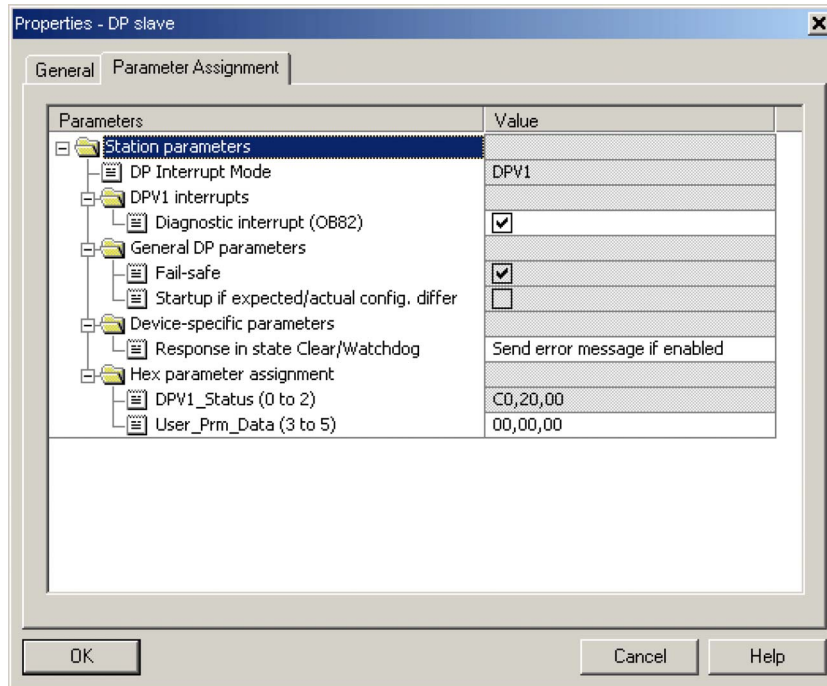

Changing the Application Layer to "DP-V0"

The configuration tool of the master lets you select the application layer to be used.

The application layer "DP-V1" is the default setting. This setting can be changed to the application layer "DP-V0".

If you want to use the application layer "DP-V0", deactivate the setting "Diagnostic interrupt" and change "DP Interrupt Mode" to "DPV0".

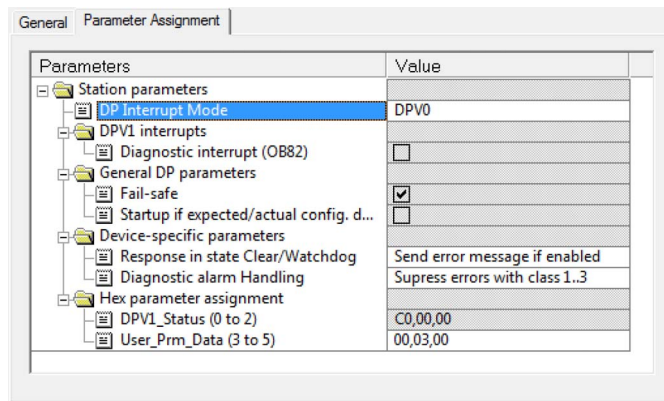

Additional Parameters in "Optional Data"

The configuration tool of the master lets you set the additional parameters to be transmitted in the output data and the input data in the range "Optional Data".

There are up to 8 slots in which 8 additional parameters can be set. The total length of the data frame of the output data and the input data must not exceed 40 bytes.

Slot	DP ID	...	Order Number / Designation	I Address	Q Address	Comment
1	195		Drive Profile Lexium 1	20...45	20...45	
2	225		Output data double word		256...259	
3	224		Output data word		260...261	
4	209		Input data double word	256...259		
5	208		Input data word	260...261		
6	0		Empty module			
7	0		Empty module			
8	0		Empty module			
9	0		Empty module			

Selection of additional output data. Example shows a 32 bit parameter.

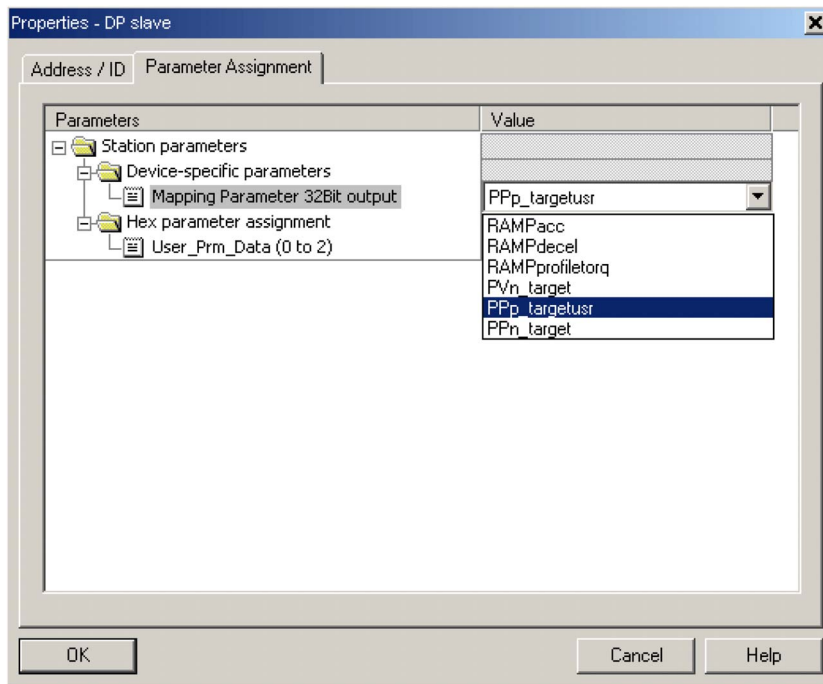

Selection of additional input data. Example shows a 32 bit parameter.

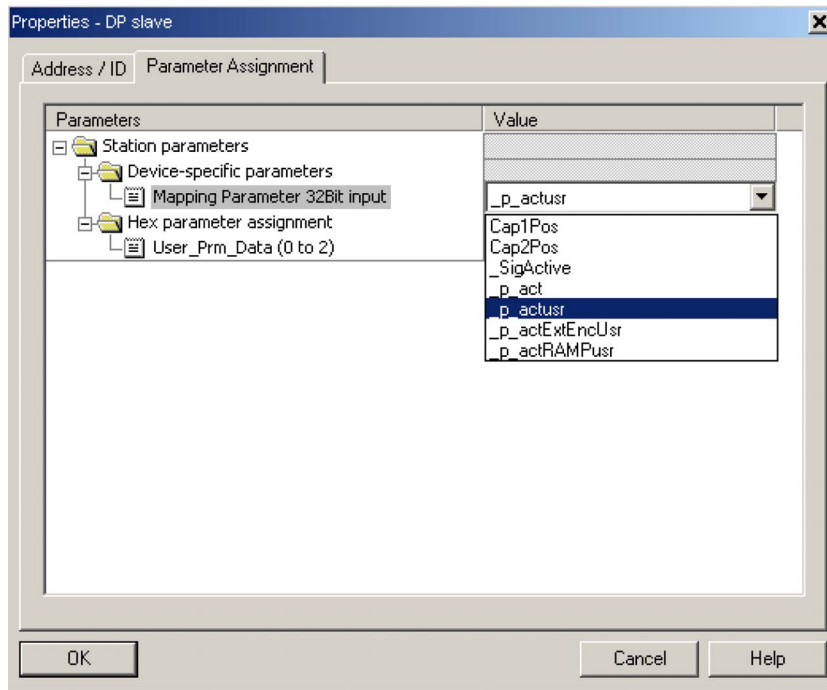

Overview of the properties of the "Drive Profile Lexium 1".

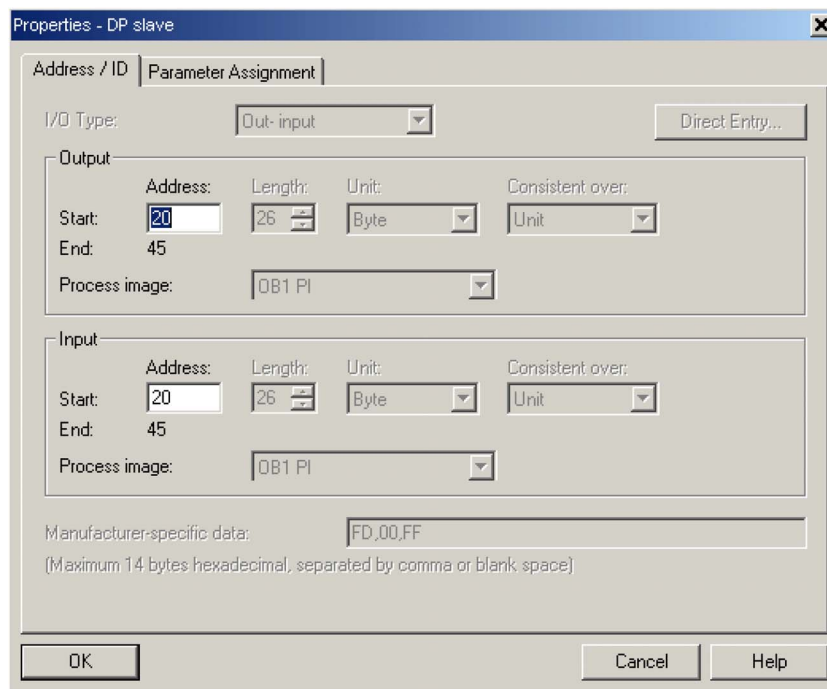

Chapter 5

Operating States and Operating Modes

What Is in This Chapter?

This chapter contains the following sections:

Section	Topic	Page
5.1	Operating States	42
5.2	Operating Modes	45

Section 5.1

Operating States

What Is in This Section?

This section contains the following topics:

Topic	Page
Indication of the Operating State via Fieldbus	43
Changing the Operating State via Fieldbus	44

Indication of the Operating State via Fieldbus

The operating state is indicated with the word "driveStat".

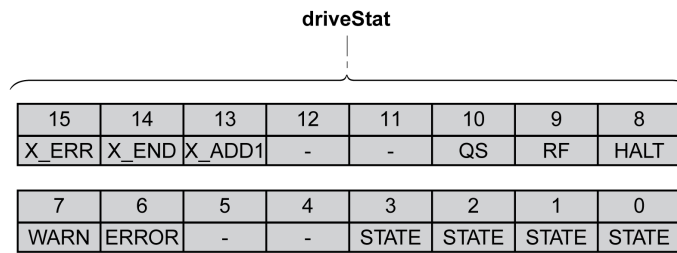

bit	Name	Meaning
0 ... 3	STATE	Operating state (binary coded) 1 Start 2 Not Ready To Switch On 3 Switch On Disabled 4 Ready To Switch On 5 Switched On 6 Operation Enabled 7 Quick Stop Active 8 Fault Reaction Active 9 Fault
4 ... 5	-	Reserved
6	ERROR	Error detected (error classes 1 ... 3)
7	WARN	Error detected (error class 0)
8	HALT	"Halt" is active
9	RF	Homing valid
10	QS	"Quick Stop" is active
11 ... 12	-	Reserved
13	X_ADD1	Operating mode-specific information
14	X_END	Operating mode terminated
15	X_ERR	Operating mode terminated with error

Changing the Operating State via Fieldbus

Bits 8 ... 15 of the word "dmControl" are used to set the operating state.

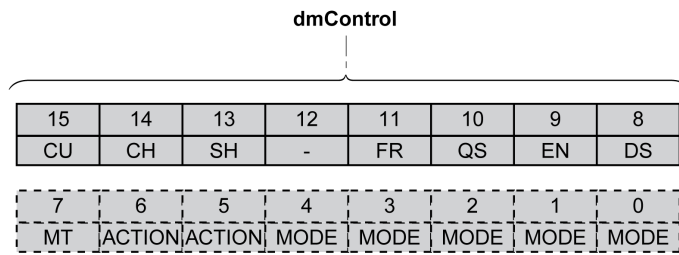

bit	Name	Meaning	Operating state
8	DS	Disabling the power stage	6 Operation Enabled -> 4 Ready To Switch On
9	EN	Enabling the power stage	4 Ready To Switch On -> 6 Operation Enabled
10	QA	Perform "Quick Stop"	6 Operation Enabled -> 7 Quick Stop Active
11	FR	Perform "Fault Reset"	7 Quick Stop Active -> 6 Operation Enabled 9 Fault -> 4 Ready To Switch On
12	-	Reserved	Reserved
13	SH	Execute "Halt"	6 Operation Enabled
14	CH	Clear "Halt"	6 Operation Enabled
15	CU	Resume operating mode interrupted by "Halt"	6 Operation Enabled

In the case of an access, the bits respond to a 0->1 change to trigger the corresponding function.

If a request for changing the operating state is not successful, this request is ignored. There is no error response.

Ambivalent bit combinations are treated in accordance with the following priority list (highest priority bit 8, lowest priority bit 14 and bit 15):

- Bit 8 (disable power stage) prior to bit 9 (enable power stage)
- Bit 10 ("Quick Stop") prior to bit 11 ("Fault Reset")
- Bit 13 (execute "Halt") prior to bit 14 (clear "Halt") and bit 15 (resume operating mode interrupted by "Halt")

In the case of an error of error class 2 or error class 3, a "Fault Reset" can only be performed when bit 9 (enable power stage) is no longer set.

Section 5.2

Operating Modes

What Is in This Section?

This section contains the following topics:

Topic	Page
Indicating an Operating Mode	46
Starting and Changing an Operating Mode	47
Overview of Operating Modes	48
Operating Mode Jog	49
Operating Mode Electronic Gear	50
Operating Mode Profile Torque	51
Operating Mode Profile Velocity	52
Operating Mode Profile Position	53
Operating Mode Homing	54
Operating Mode Motion Sequence	55

Indicating an Operating Mode

The word “mfStat” is used to indicate the set operating mode.

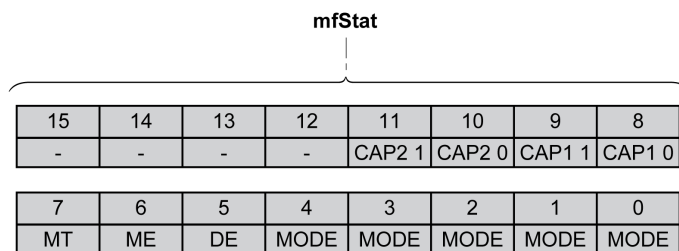

bit	Name	Description
0 ... 4	MODE	Indicates the set operating mode Value 01 _h : Profile Position Value 03 _h : Profile Velocity Value 04 _h : Profile Torque Value 06 _h : Homing Value 1D _h : Motion Sequence Value 1E _h : Electronic Gear Value 1F _h : Jog
5	DE	The “DE” bit relates to parameters that are independent of “Mode Toggle” (MT). The “DE” bit is set if a data value in the process data channel is invalid.
6	ME	The “ME” bit relates to parameters that are dependent on “Mode Toggle” (MT). The “ME” bit is set if a request (for example, starting an operating mode) was rejected.
7	MT	Handshake via “Mode Toggle”
8 ... 9	CAP1	Bit 0 and bit 1 of parameter <code>_Cap1Count</code>
10 ... 11	CAP2	Bit 0 and bit 1 of parameter <code>_Cap2Count</code>
12 ... 15	-	Reserved

Starting and Changing an Operating Mode

Starting and Changing an Operating Mode

Bits 0 ... 7 in the word "dmControl" are used to set the operating mode.

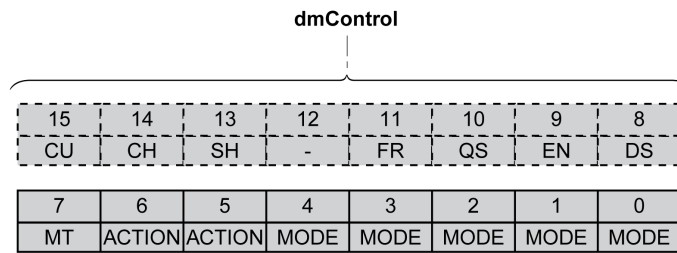

bit	Name	Description
0 ... 4	MODE	Operating Mode Value 01 _h : Profile Position Value 03 _h : Profile Velocity Value 04 _h : Profile Torque Value 06 _h : Homing Value 1D _h : Motion Sequence Value 1E _h : Electronic Gear Value 1F _h : Jog
5 ... 6	ACTION	Operating mode-dependent
7	MT	Handshake via Mode Toggle

Via the following values the operating mode can be activated or target values can be changed:

- Target values, depending on required operating mode
- Operating mode in "dmControl", bits 0 ... 4 (MODE).
- Action for this operating mode in bit 5 and bit 6 (ACTION)
- Toggle bit 7 (MT)

The following chapters describe the possible operating modes, functions and the corresponding target values.

Overview of Operating Modes

Operating Mode	dmControl Bits 0 ... 6 MODE+ACTION	RefA32	RefB32
JOG	1F _h	Value 0: No movement Value 1: Slow movement in positive direction Value 2: Slow movement in negative direction Value 5: Fast movement in positive direction Value 6: Fast movement in negative direction	-
Electronic Gear: Position synchronization without compensation movement	1E _h	As GEARdenom	As GEARnum
Electronic Gear: Position synchronization with compensation movement	3E _h	As GEARdenom	As GEARnum
Electronic Gear: Velocity synchronization	5E _h	As GEARdenom	As GEARnum
Profile Torque: Via analog input	04 _h	-	-
Profile Torque: Via parameter	24 _h	As PTtq_target	As RAMP_tq_slope
Profile Torque: Via PTI interface	44 _h	-	-
Profile Velocity: Via analog input	03 _h	-	-
Profile Velocity: Via parameter	23 _h	As PVv_target	-
Profile Position: Absolute	01 _h	As PPv_target	As Ppp_target
Profile Position: Relative with reference to the currently set target position	21 _h	As PPv_target	As Ppp_target
Profile Position: Relative with reference to the motor position	41 _h	As PPv_target	As Ppp_target
Homing: Position setting	06 _h	-	As HMp_setP
Homing: Reference Movement	26 _h	As HMmethod	-
Motion Sequence: Start sequence	1D _h	Data set number	Value 1: Use data set number
Motion Sequence: Start individual data set	3D _h	Data set number	-

Operating Mode Jog

Starting the Operating Mode

The operating mode is set and started in the process data channel with the output data.

dmControl Bits 0 ... 6 MODE+ACTION	RefA32	RefB32
1F _h	Value 0: No movement Value 1: Slow movement in positive direction Value 2: Slow movement in negative direction Value 5: Fast movement in positive direction Value 6: Fast movement in negative direction	-

Status Information

The word "driveStat" provides information on the operating mode.

bit	Name	Meaning
13	X_ADD1	Reserved
14	X_END	0: Operating mode started 1: Operating mode terminated
15	X_ERR	0: No error detected 1: Error detected

Terminating the Operating Mode

The operating mode is terminated when the motor is at a standstill and one of the following conditions is met:

- Value 0 RefA
- Stop caused by "Halt" or "Quick Stop"
- Stop caused by a detected error

Operating Mode Electronic Gear

Starting the Operating Mode

The operating mode is set and started in the process data channel with the output data.

Method	dmControl Bits 0 ... 6 MODE+ACTION	RefA32	RefB32
Position synchronization without compensation movement	1E _h	As GEARdenom	As GEARnum
Position synchronization with compensation movement	3E _h	As GEARdenom	As GEARnum
Velocity synchronization	5E _h	As GEARdenom	As GEARnum

Status Information

The word "driveStat" provides information on the operating mode.

bit	Name	Meaning
13	X_ADD1	1: Reference velocity reached ⁽¹⁾
14	X_END	0: Operating mode started 1: Operating mode terminated
15	X_ERR	0: No error detected 1: Error detected
(1) Only with method Velocity synchronization and with active velocity window.		

Terminating the Operating Mode

The operating mode is terminated when the motor is at a standstill and one of the following conditions is met:

- Stop caused by "Halt" or "Quick Stop"
- Stop caused by a detected error

Operating Mode Profile Torque

Starting the Operating Mode

The operating mode is set and started in the process data channel with the output data.

Method	dmControl Bits 0 ... 6 MODE+ACTION	RefA32	RefB32
Via analog input	04 _h	-	-
Via parameter	24 _h	As $PTtq_target$	As $RAMP_tq_slope$
Via PTI interface	44 _h	-	-

Status Information

The word "driveStat" provides information on the operating mode.

bit	Name	Meaning
13	X_ADD1	0: Target torque not reached 1: Target torque reached
14	X_END	0: Operating mode started 1: Operating mode terminated
15	X_ERR	0: No error detected 1: Error detected

Terminating the Operating Mode

The operating mode is terminated when the motor is at a standstill and one of the following conditions is met:

- Stop caused by "Halt" or "Quick Stop"
- Stop caused by a detected error

Operating Mode Profile Velocity

Starting the Operating Mode

The operating mode is set and started in the process data channel with the output data.

Method	dmControl Bits 0 ... 6 MODE+ACTION	RefA32	RefB32
Via analog input	03 _h	-	-
Via parameter	23 _h	As PVv_target	-

Status Information

The word "driveStat" provides information on the operating mode.

bit	Name	Meaning
13	X_ADD1	0: Target velocity not reached 1: Target velocity reached
14	X_END	0: Operating mode started 1: Operating mode terminated
15	X_ERR	0: No error detected 1: Error detected

Terminating the Operating Mode

The operating mode is terminated when the motor is at a standstill and one of the following conditions is met:

- Stop caused by "Halt" or "Quick Stop"
- Stop caused by a detected error

Operating Mode Profile Position

Starting the operating mode

The operating mode is set and started in the process data channel with the output data.

Method	dmControl Bits 0 ... 6 MODE+ACTION	RefA32	RefB32
Absolute	01 _h	As PPv_target	As Ppp_target
Relative with reference to the currently set target position	21 _h	As PPv_target	As Ppp_target
Relative with reference to the current motor position	41 _h	As PPv_target	As Ppp_target

Status Information

The word "driveStat" provides information on the operating mode.

bit	Name	Meaning
13	X_ADD1	0: Target position not reached 1: Target position reached
14	X_END	0: Operating mode started 1: Operating mode terminated
15	X_ERR	0: No error detected 1: Error detected

Terminating the Operating Mode

The operating mode is terminated when the motor is at a standstill and one of the following conditions is met:

- Target position reached
- Stop caused by "Halt" or "Quick Stop"
- Stop caused by a detected error

Operating Mode Homing

Starting the Operating Mode

The operating mode is set and started in the process data channel with the output data.

Method	dmControl Bits 0 ... 6 MODE+ACTION	RefA32	RefB32
Position setting	06 _h	-	As HMp_setP
Reference movement	26 _h	As HMmethod	-

Status Information

The word "driveStat" provides information on the operating mode.

bit	Name	Meaning
13	X_ADD1	Reserved
14	X_END	0: Operating mode started 1: Operating mode terminated
15	X_ERR	0: No error detected 1: Error detected

Terminating the Operating Mode

The operating mode is terminated when the motor is at a standstill and one of the following conditions is met:

- Homing successful
- Stop caused by "Halt" or "Quick Stop"
- Stop caused by a detected error

Operating Mode Motion Sequence

Starting the Operating Mode

The operating mode is set and started in the process data channel with the output data.

Method	dmControl Bits 0 ... 6 MODE+ACTION	RefA32	RefB32
Start sequence	1D _h	Data set number	Value 1: Use data set number
Start individual data set	3D _h	Data set number	-

Status Information

The word "driveStat" provides information on the operating mode.

bit	Name	Meaning
13	X_ADD1	1: End of a sequence
14	X_END	0: Operating mode started 1: Operating mode terminated
15	X_ERR	0: No error detected 1: Error detected

Terminating the Operating Mode

The operating mode is terminated when the motor is at a standstill and one of the following conditions is met:

- Individual data set terminated
- Individual data set of a sequence terminated (waiting for transition condition to be fulfilled)
- Sequence terminated
- Stop caused by "Halt" or "Quick Stop"
- Stop caused by a detected error

Chapter 6

Diagnostics and Troubleshooting

What Is in This Chapter?

This chapter contains the following topics:

Topic	Page
Fieldbus Communication Error Diagnostics	58
Fieldbus Test	59
Fieldbus Status LEDs	60
Error Messages	61

Fieldbus Communication Error Diagnostics

Checking Connections

A properly operating fieldbus is essential for evaluating status and error messages.

If the product cannot be addressed via the fieldbus, first verify the connections.

Verify the following connections:

- System power supply
- Supply connections
- Fieldbus cables and wiring
- Fieldbus connection

Fieldbus Function Test

If the connections are correct, verify that you can address the product on the fieldbus.

Fieldbus Test

Fieldbus Function Test

If the connections are correct, verify the settings for the fieldbus addresses. After configuration of the transmission data, test the fieldbus mode.

In addition to the master that knows the product via the data in the GSD file and the address, install a bus monitor that, as a passive device, displays messages.

- Power cycle the drive.
- Observe the network messages that are generated immediately after the supply voltage is applied. A bus monitor can be used to record the elapsed time between messages and the relevant information in the messages.

Potential Errors: Addressing, Parameterization, Configuration

If you cannot connect to a device, verify the following:

- Addressing: The address of the network device must be between 1 and 126. Each network device must have a unique address.
- Parameterization: The parameterized Ident number and the user parameters must match the values stored in the GSD file.
- Configuration: The data length in input and output direction must be identical to the length specified in the GSD file.

Fieldbus Status LEDs

The fieldbus status LEDs visualize the status of the fieldbus.

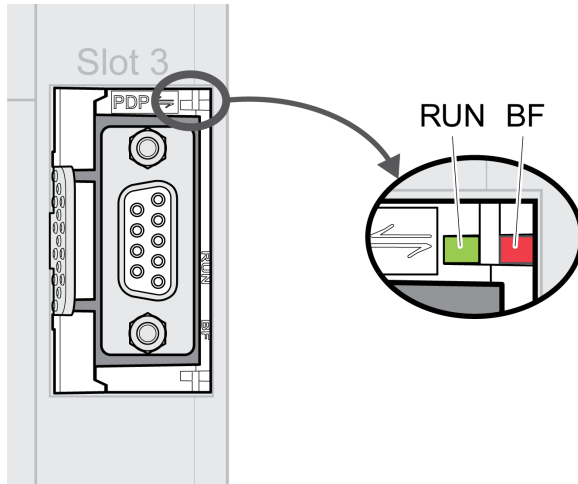

LED "RUN" (green)	LED "BF" (red)	Meaning
Off	Off	Fieldbus communication inactive
On	Off	Fieldbus communication active
Off	On	Fieldbus error (for example, watchdog)
Off	Flashes	Master not ready or incorrect parameterization

Error Messages

Overview

Error messages generated during operation on network are received by the master via the fieldbus.

The following error messages are possible:

- Synchronous errors
- Asynchronous errors
- Errors during operating mode control via process data channel.

Error Message in Parameter Channel

If a command cannot be processed in the parameter channel, the master receives a synchronous error message from the slave.

In the case of a synchronous error message, the input data contains the following information:

Ctrl	Subindex	Index	PV
70 _h	00 _h	Contains the address of the parameter	Contains the error number

Error Message in Process Data Channel

If a command cannot be processed in the process data channel, bit 6 (ModeError, ME) in the word "mfStat" is set in the input data.

Data such as position and velocity is transmitted via the process data channel. If the data is not accepted (for example, if the value is outside of the permissible range), bit 5 (DataError, DE) is set in the input data in the word "mfStat".

Bit	Name	Description
5	DE	The DataError bit relates to parameters that are independent of "Mode Toggle" (MT). It is set if a data value in the process data channel is invalid.
6	ME	The ModeError bit relates to parameters that are dependent on "Mode Toggle" (MT). Is set if a request from a master (starting an operating mode) was rejected

If DE or ME are set, this does not interrupt the ongoing movement. To determine the cause of the error, the master can read the error number from the parameters `_DataError`, 6966:00 and `_ModeError`, 6962:00.

In order to identify the parameter that has caused the DE bit or the ME bit to be set, the position of the parameter can be read from the parameters `_DataErrorInfo`, 6970:00 and `_ModeErrorInfo`, 6968:00.

Overview for "Drive Profile Lexium 1"

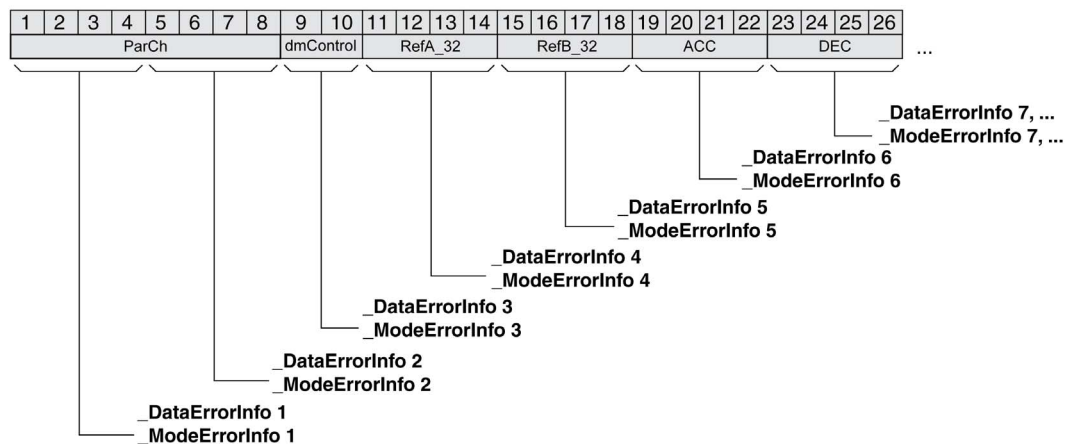

Overview for "Drive Profile Lexium 2"

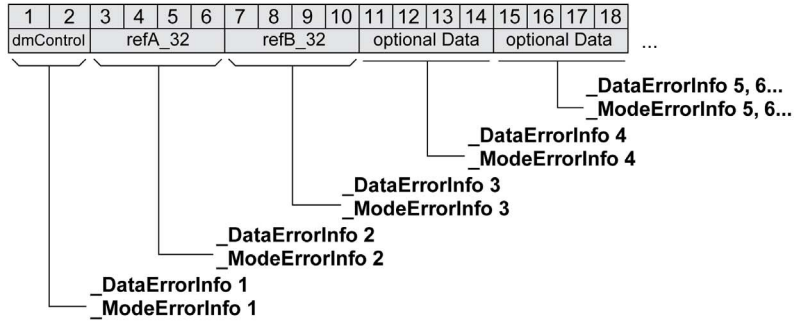

The error message is reset when the next valid data frame is transmitted.

Asynchronous Errors

Asynchronous errors are triggered by internal monitoring functions (for example, temperature) or by external monitoring functions (for example, limit switch).

Asynchronous errors are indicated in the following way:

- Transition to operating state 7 Quick Stop Active or to operating state 9 Fault (see "driveStat", bits 0 ... 3)
- Setting of:
 - "driveStat" bit 6 (error of error classes 1 ... 4)
 - "driveStat" bit 7 (error of error class 0)
 - "driveStat", bit 15 (operating mode terminated with detected error).

The error bits have the following meaning:

- Bit 6
 - Error of error classes 1 ... 4
 - The cause is contained in parameter `_LastError` in a bit-coded way.
- Bit 7
 - Error of error class 0
 - The error information is contained in parameter `_LastWarning` in a bit-coded way.
- Bit 15
 - Indicates whether the operating mode was terminated by an error.

DP-V1: Acyclic Alarm with MS1 Communication

If the device is operated as a Profibus DP-V1 device and transitions to the operating state 9 Fault, the slave sends a vendor-specific data frame to the master:

Acyclic error message with MS1 communication (slave to master)

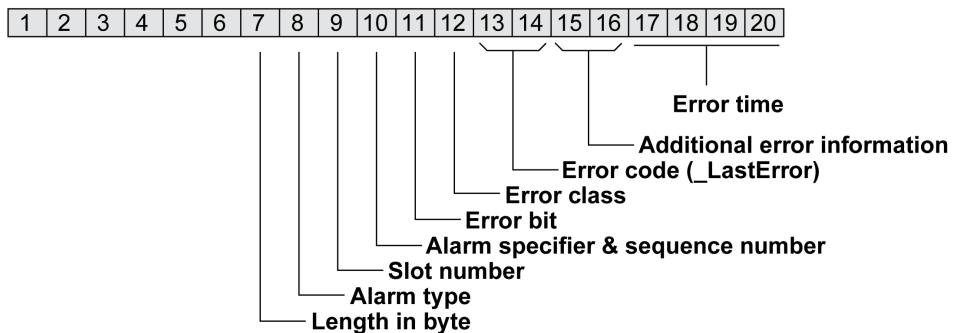

The master sends an Acknowledge frame in response to this data frame:
Acyclic acknowledgement with MS1 communication (master to slave)

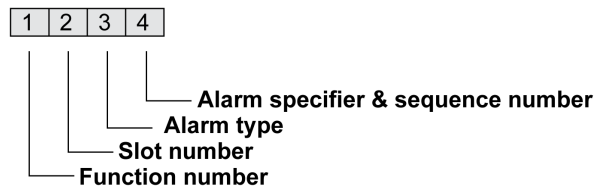

It is possible to inhibit transmission of confirmations. Use the configuration tool of the master to make this setting.



B

Big Endian format

Method of storing data; the highest-value byte of a data word is at the first position (big end first).

D

DE

DataError-Bit. The DataError bit relates to parameters that are independent of "Mode Toggle" (MT). It is set if a data value in the process data channel is invalid.

Direction of movement

In the case of a rotary motors, direction of movement is defined in accordance with IEC 61800-7-204: Positive direction is when the motor shaft rotates clockwise as you look at the end of the protruding motor shaft.

DOM

Date of manufacturing: The nameplate of the product shows the date of manufacture in the format DD.MM.YY or in the format DD.MM.YYYY. For example:

31.12.11 corresponds to December 31, 2011

31.12.2011 corresponds to December 31, 2011

E

EMC

Electromagnetic compatibility

Error

Discrepancy between a detected (computed, measured or signaled) value or condition and the specified or theoretically correct value or condition.

Error class

Classification of errors into groups. The different error classes allow for specific responses to errors, for example by severity.

F

Factory settings

Settings when the product is shipped.

Fault

Fault is an operating state. If the monitoring functions detect an error, a transition to this operating state is triggered, depending on the error class. A "Fault Reset" or a power cycle are required to exit this operating state. Prior to this, the cause of the detected error must be removed. Further information can be found in the pertinent standards such as IEC 61800-7, ODVA Common Industrial Protocol (CIP).

Fault Reset

Function used to exit the operating state Fault. Before the function is used, the cause of the detected error must be removed.

G

GSD file

A file that is provided by the vendor and contains specific information on the product.

L

Limit switch

Switches that signal overtravel of the permissible movement range.

Little Endian format

Method of storing data; the lowest-value byte of a data word is at the first position (little end first).

M

ME

ModeError-Bit. The ModeError bit relates to parameters that are dependent on "Mode Toggle" (MT). It is set if a request (for example, starting an operating mode) was rejected.

MT

Mode Toggle, toggling a bit from 0 -> 1 or 1 -> 0

Q

Quick Stop

The function can be used for fast deceleration of a movement as a response to a detected error or via a command.

T

Toggle

See MT, Mode Toggle



B

before you begin
 safety information, 5

I

intended use, 6

O

operating states, 42

Q

qualification of personnel, 5

