



SAPPB2D-08X0044

Safe Robotics Area Protection

SAFETY SYSTEMS FOR ROBOTS

SICK
Sensor Intelligence.



Ordering information

sBot Stop

Robot restart	Primary protective device (access control)	Secondary protective device (presence detection)	Type	Part no.
Manual	Multiple light beam safety device deTem4 Core Number of beams: 4 Beam separation: 300 mm	Safety laser scanners S300 Mini Standard Protective field range: 3 m	SAPPB2D-08X0044	1097904

This system variant enables a manual restart of the robot.

Other models and accessories → www.sick.com/Safe_Robotics_Area_Protection

Detailed technical data

Features

Variant	sBot Stop
Product type	Hardware and logics
Robot controller	Generic
Stopping process of the robot	Stop only
Robot restart	Manual
Interfaces	
Communication interface	Discrete I/Os
Safe state in the event of a fault	The safety-related semiconductor outputs are in the OFF state.
Safety laser scanners	S300 Mini Standard
Protective field range	3 m
Safety task	Hazardous area protection
Ambient operating temperature	-10 °C ... +50 °C
Storage temperature	-20 °C ... +50 °C
Air humidity	90% at 50 °C (EN 61131-2)
Safety sensors	
Primary protective device (access control)	Safety multibeam sensors
Secondary protective device (presence detection)	Safety laser scanners
Safety multibeam sensors	deTem4 Core
Number of beams	4
Beam separation	300 mm
Scanning range	17 m
Safety controller included	Flexi Classic
Safety controller type	Non programmable
Voltage supply	

Supply voltage V_S	24 V DC (16.8 V DC ... 28.8 V DC)
Performance level	PL d (ISO 13849-1)
Items supplied	S300 Mini Standard safety laser scanner deTem4 Core multiple light beam safety device sender and receiver Flexi Classic main module UE410-MU4T0 FlexFix brackets Documentation (operating instructions, SISTEMA file, wiring diagram)

Functions

Initiate a safety stop	
Manual reset	✓
Operating mode	
Operating mode selection (implemented in robot control)	✓

Classifications

ECLASS 5.0	27279090
ECLASS 5.1.4	27279090
ECLASS 6.0	27279090
ECLASS 6.2	27279090
ECLASS 7.0	27279090
ECLASS 8.0	27279090
ECLASS 8.1	27279090
ECLASS 9.0	27279090
ECLASS 10.0	27279090
ECLASS 11.0	27279090
ECLASS 12.0	27279090
ETIM 5.0	EC001449
ETIM 6.0	EC001449
ETIM 7.0	EC001449
ETIM 8.0	EC001449
UNSPSC 16.0901	32151705

Dimensional drawing (Dimensions in mm (inch))

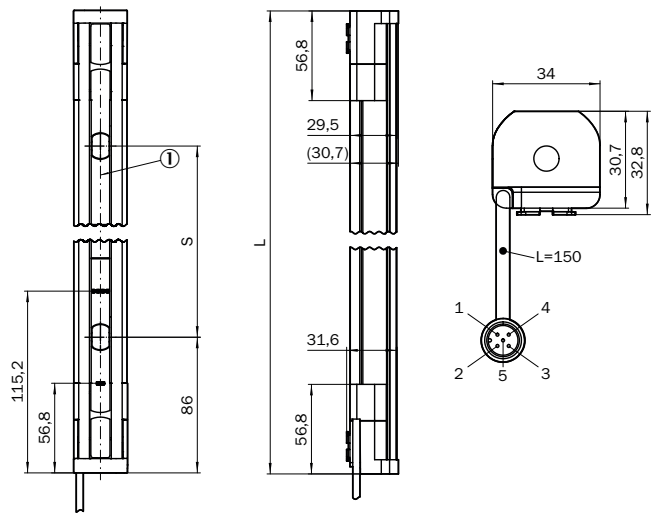

① Optical axis

Flexi Classic main module

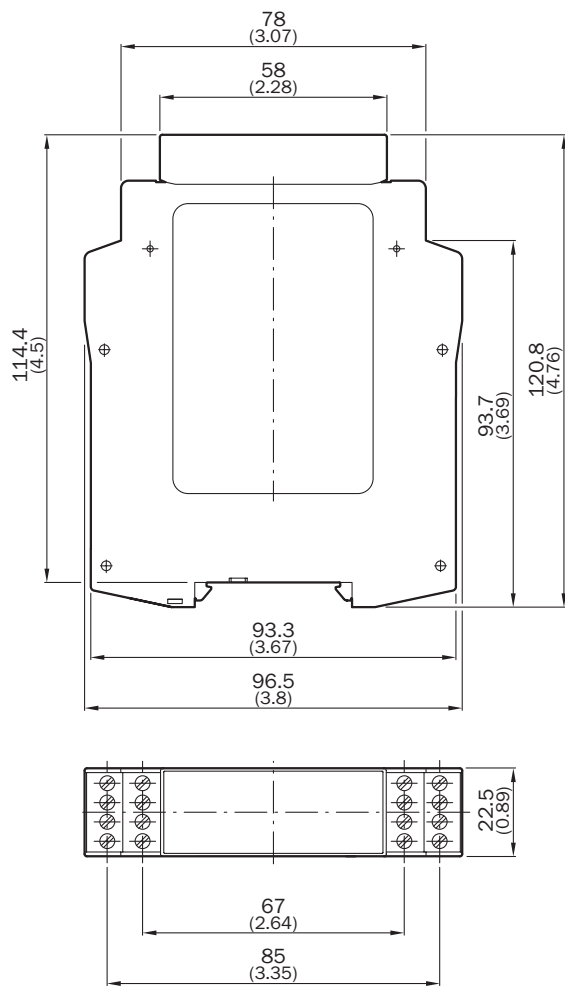

Laser scanner

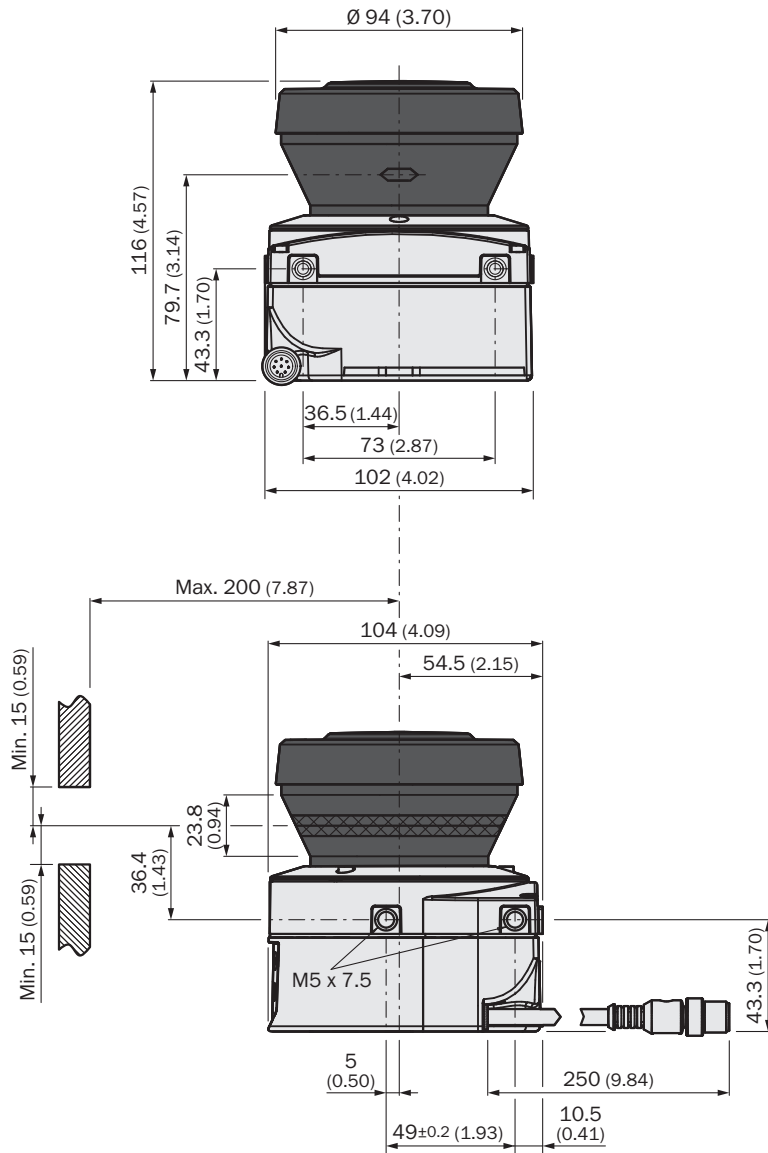

Number of beams	Beam separation S	Length L
2	500 (19.69)	672 (26.46)
3	400 (15.75)	972 (38.27)
4	300 (11.81)	1,072 (42.2)

SICK AT A GLANCE

SICK is one of the leading manufacturers of intelligent sensors and sensor solutions for industrial applications. A unique range of products and services creates the perfect basis for controlling processes securely and efficiently, protecting individuals from accidents and preventing damage to the environment.

We have extensive experience in a wide range of industries and understand their processes and requirements. With intelligent sensors, we can deliver exactly what our customers need. In application centers in Europe, Asia and North America, system solutions are tested and optimized in accordance with customer specifications. All this makes us a reliable supplier and development partner.

Comprehensive services complete our offering: SICK LifeTime Services provide support throughout the machine life cycle and ensure safety and productivity.

For us, that is “Sensor Intelligence.”

WORLDWIDE PRESENCE:

Contacts and other locations –www.sick.com