

Diagrams & dimensions

Thinking of making your job easier. We create these supports to optimize your time. We provide all the technical information, diagrams and dimensions of each of our products in a clear and precise manner to facilitate understanding.

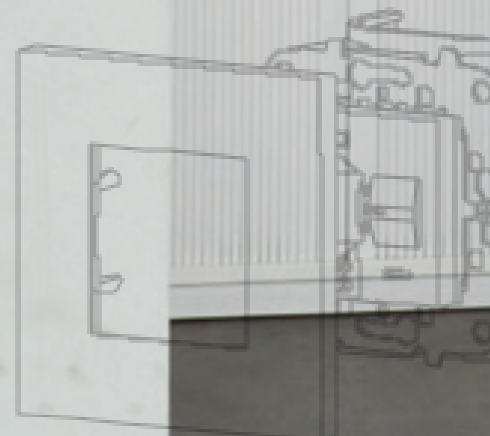

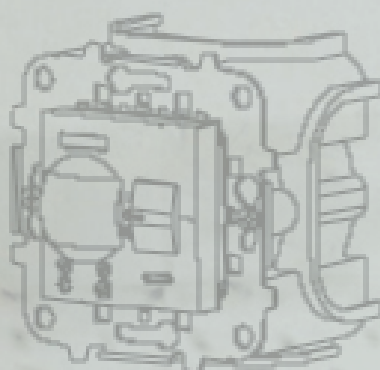
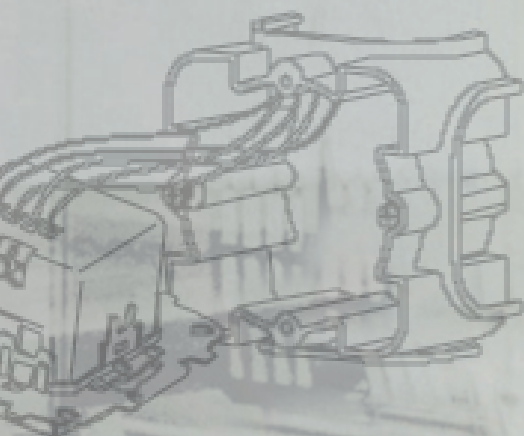
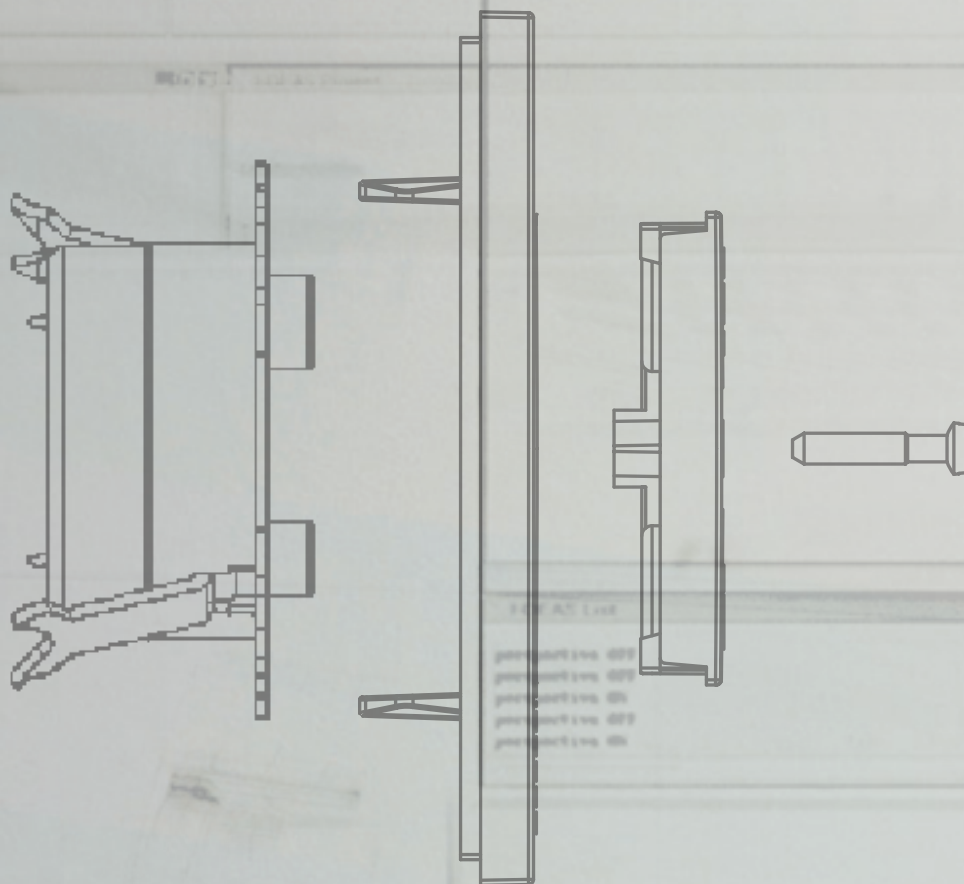

Switches

Optional: locator light

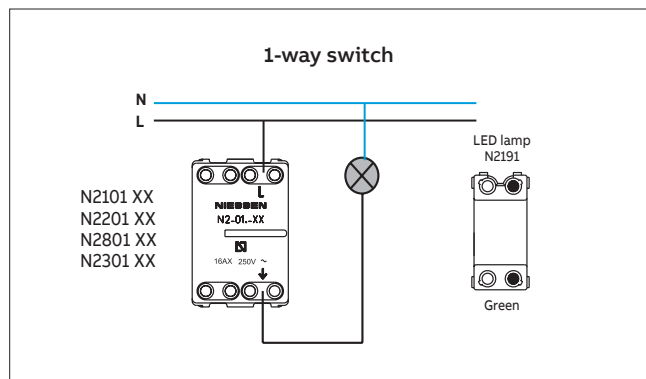

With indicator light

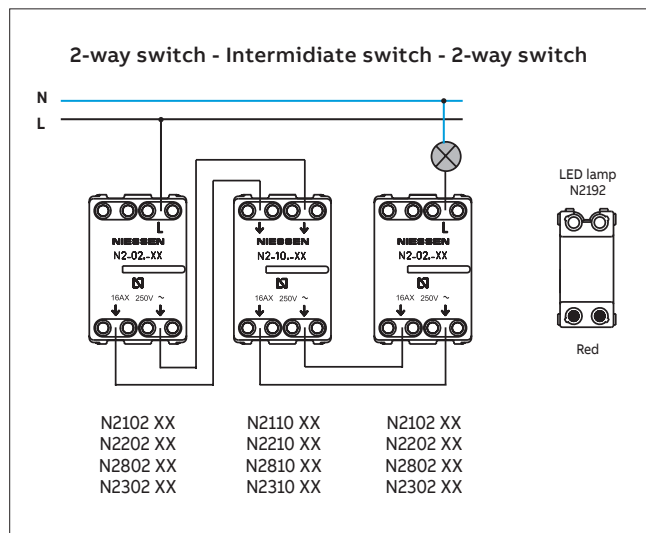
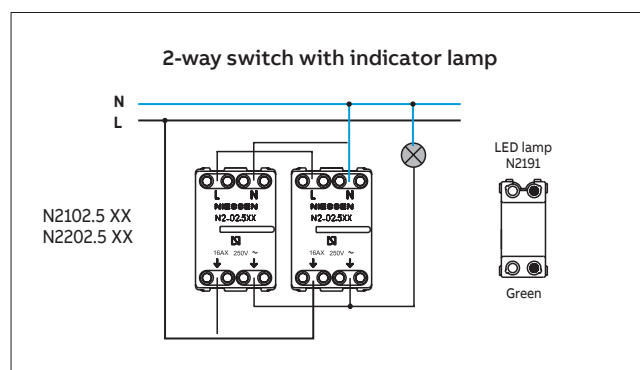
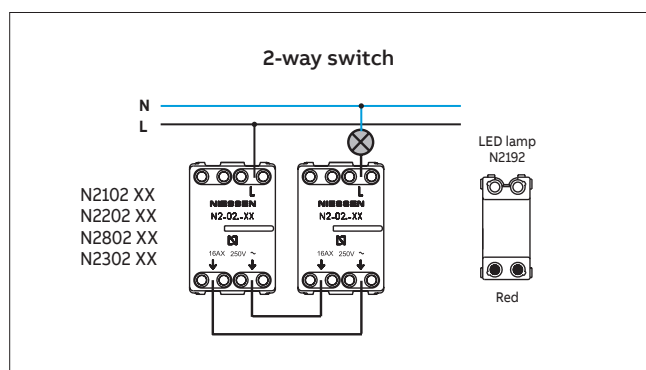
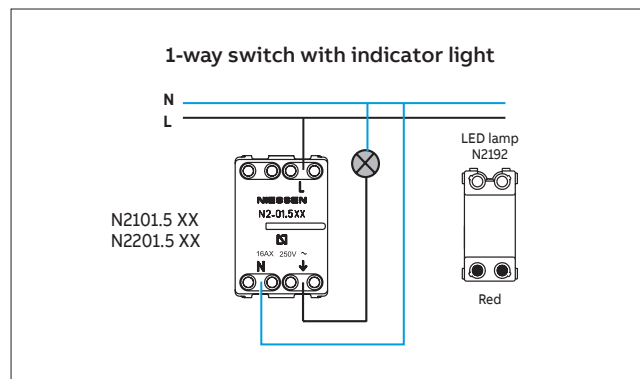

Push-buttons

Optional: locator light

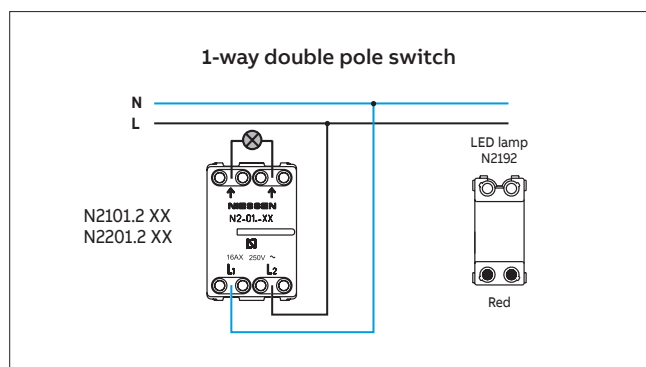
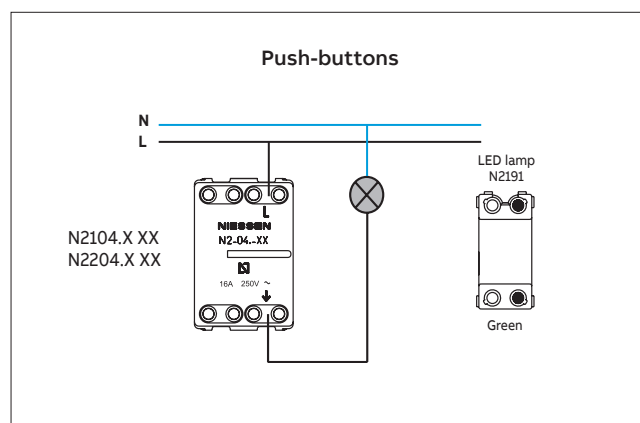

Push-buttons

With locator or indicator light

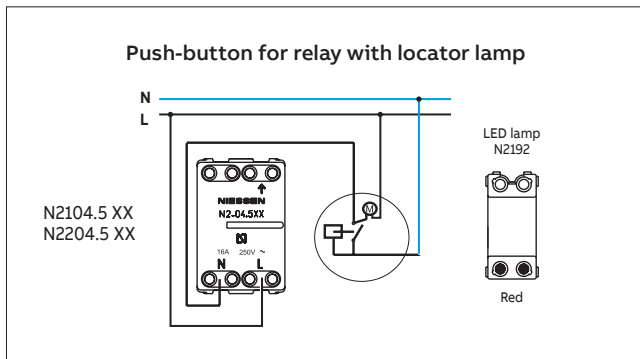
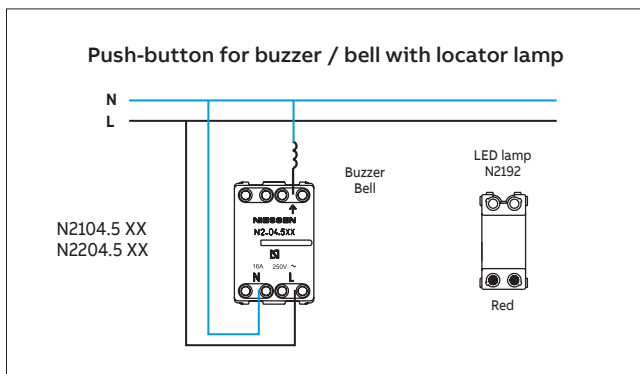
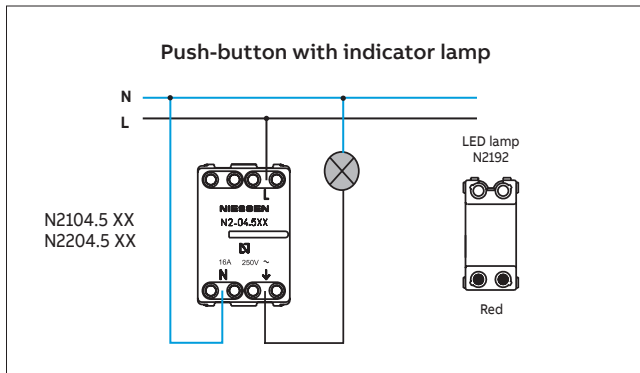

Card switch

With locator light

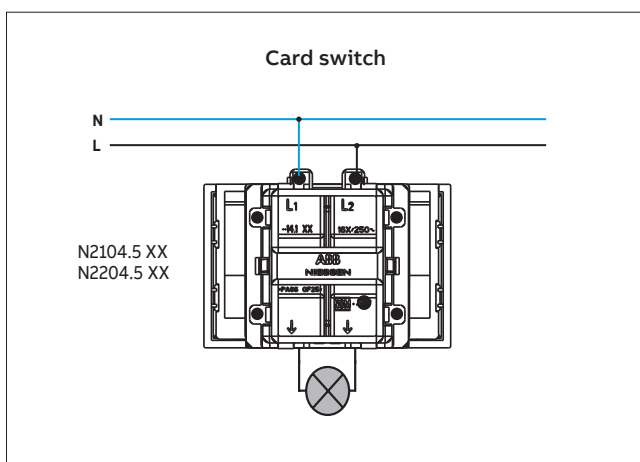

Card timer switch

With locator light

1- Technical Data

Power Supply: 127 V~ / 60 Hz
230 V~ / 50 Hz

Night orientation: By a red LED
Operating T°: 0° C +40° C

Maximum power:

127 V~ / 60 Hz:

☀️1600 W, ☀️1600 W, ☀️1600 W, ☀️1600 W, ☀️700 W

230 V~ / 50 Hz:

☀️3000 W, ☀️3000 W, ☀️3000 W, ☀️1600 W, ☀️1300 W

2.- Mounting and connection scheme

2.1.- Mounting

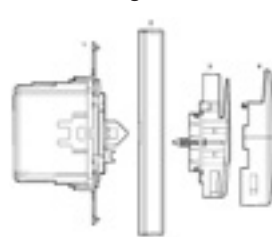

2.2.- Connection

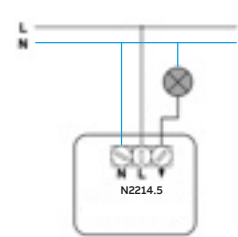

Important: Disconnect the electrical power when installing.

3.- Operation

Time selector for disconnection: The load time disconnection, after removing the card, can be programmed by the user through the rotary programme selector on the device cover.



Option	Time until disconnection		Previous status	Current Status	Action
	50Hz	60Hz			
1.-	5 s.	4 s.	No card	Card detected	Connects load
2.-	10 s.	8 s.			
3.-	20 s.	16 s.			
4.-	30 s.	25 s.	Card detected	No card	Disconnects the load at preset time
5.-	60 s.	50 s.			
6.-	90 s.	75 s.			

Blind switch & push-button

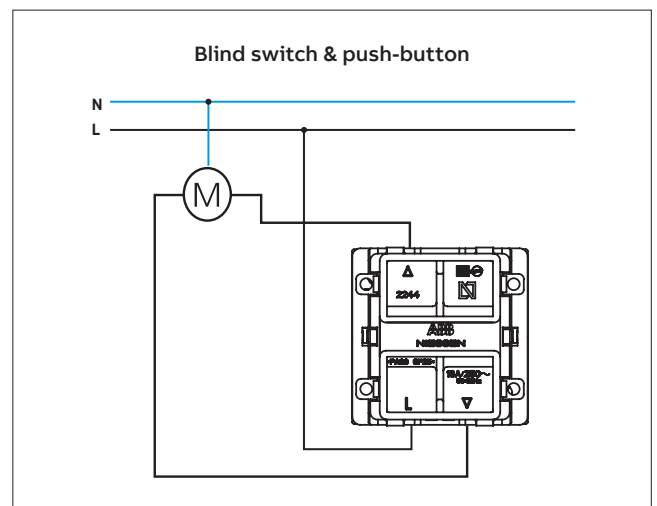

Electronic blind switch

N2261.2

Technical data:

- Power Supply: 230V~ 50Hz / 127V~ 60Hz
- Maximum power:
 - 230V~ 50Hz blind motors: 2x 700VA persianas (cos $\psi = 0,5$)
 - 127V~ 60Hz blind motors: 2x 350VA persianas (cos $\psi = 0,5$)
- Room temperature for operation: 0°C to 40°C
- According to: UNE-21806 y EN-55014

Functional features:

The electronic blind switch includes 3 modes of operation (to be selected in the rotatory switch):

- P: standard blinds control. Optionally other N2244 inserts can be connected to the N2261.2 to control the blind from ot
- V: venetian type blinds control. Optionally other N2244 inserts can be connected to the N2261.2 to control the blind from other locations.
- C: centralization. one N2261.2 can control all the N2261.2 centrally.



Wiring diagram:

- Direct blind control with a N2261.2 (Fig. 1).
- Remote control of the N2261.2 electronic blind control by using a blind push-button N2244 (Fig. 2).
- Centralized control of all the blind from one point by using a electronic blind switch N2261.2 as master of the rest electronic blind switches N2261.2 (Fig. 3).

Fig. 1

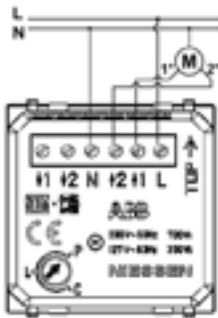

Fig. 2

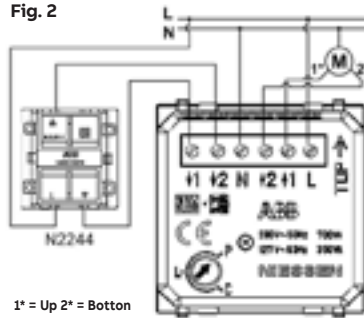
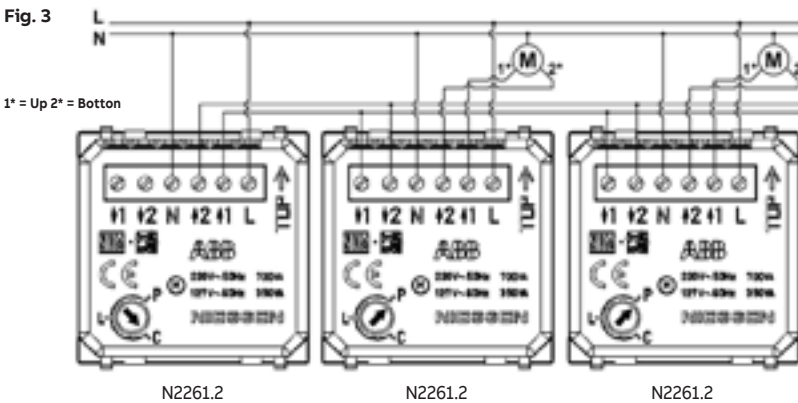

Fig. 3



Mounting:

Follow the steps below to install the mechanism:

1. Connect the device according to the connection schemes. Figure 1, 2 or 3.
2. Assemble the device on the flush mounting box.
3. Then, place the plate.

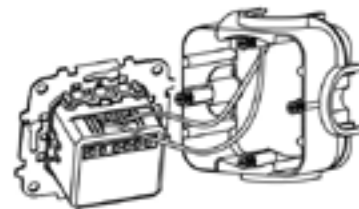

1.

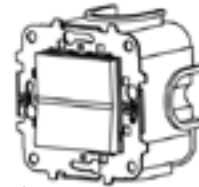

2.

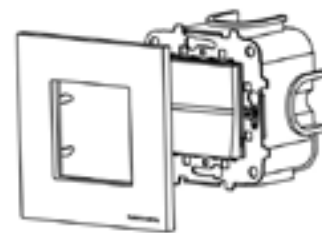

3.

Operation:	Blind operating mode.	Slats or Venetian blinds operating mode.	Centralized operating mode.
Pulsation	Action	Action	Action
Short pulsation ▲ < 300ms	Raises the blind (3 min.), if it was previously stationary. It will stop the blind, if it was previously moving.	Raise the blind (3 min.) if it was previously stationary. It will stop the blind, if it was previously moving.	Raises the blinds (of those inserts connected), if they were previously stationary. It will stop the blinds, if they were previously moving.
Short pulsation ▼ > 300ms	Lowers the blind (3 min.), if it was previously stationary. It will stop the blind, if it was previously moving.	Lowers the blind (3 min.), if it was previously stationary. It will stop the blind, if it was previously moving.	Lowers the blinds (of those inserts connected), if they were previously stationary. It will stop the blinds, if they were previously moving.
Long pulsation ▲ < 300ms	Raises the blind while the pulsation lasts, if it was previously stationary. It will stop the blind, if it was previously moving.	The slats will rotate in a pulsed way upwards while the pulsation lasts, if the blind was previously stationary. If the pulsation lasts longer, the blind will raise for as long as the pulsation lasts. It will stop the blind, if it was previously moving.	Raises the blinds (of those connected mechanisms), if they were previously stationary. It will stop the blinds, if they were previously moving.
Long pulsation ▼ > 300ms	Lowers the blind while the pulsation lasts, if it was previously stationary. It will stop the blind, if it was previously moving.	The slats will rotate in a pulsed way downwards while the pulsation lasts, if the blind was previously stationary. If the pulsation lasts longer, the blind will raise for as long as the pulsation lasts. It will stop the blind, if it was previously moving.	Lowers the blinds (of those connected mechanisms), if they were previously stationary. It will stop the blinds, if they were previously moving.

Key switches

2-way / 3 positions

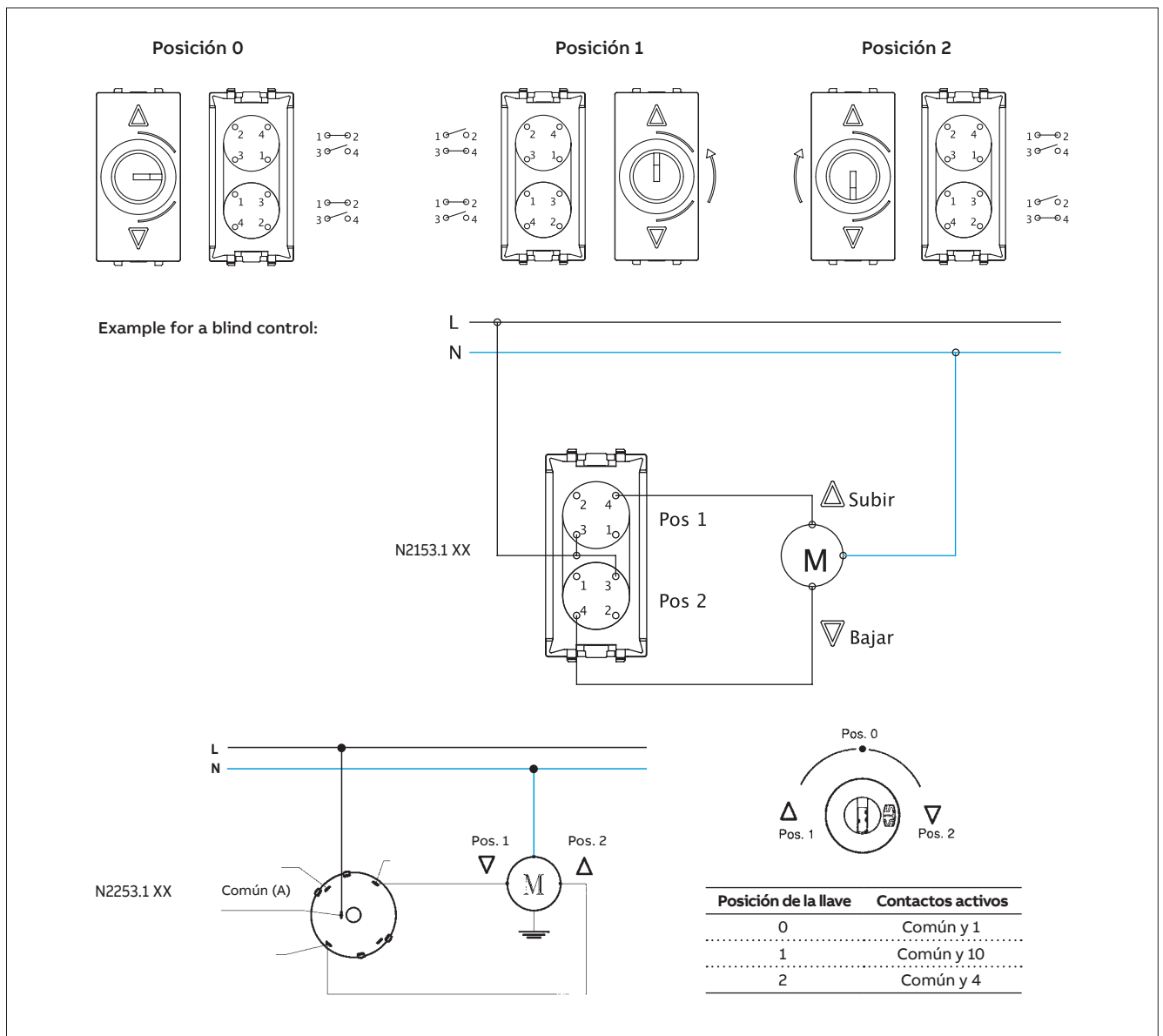

Key switches & push-buttons

1 or 2-way / 2 positions

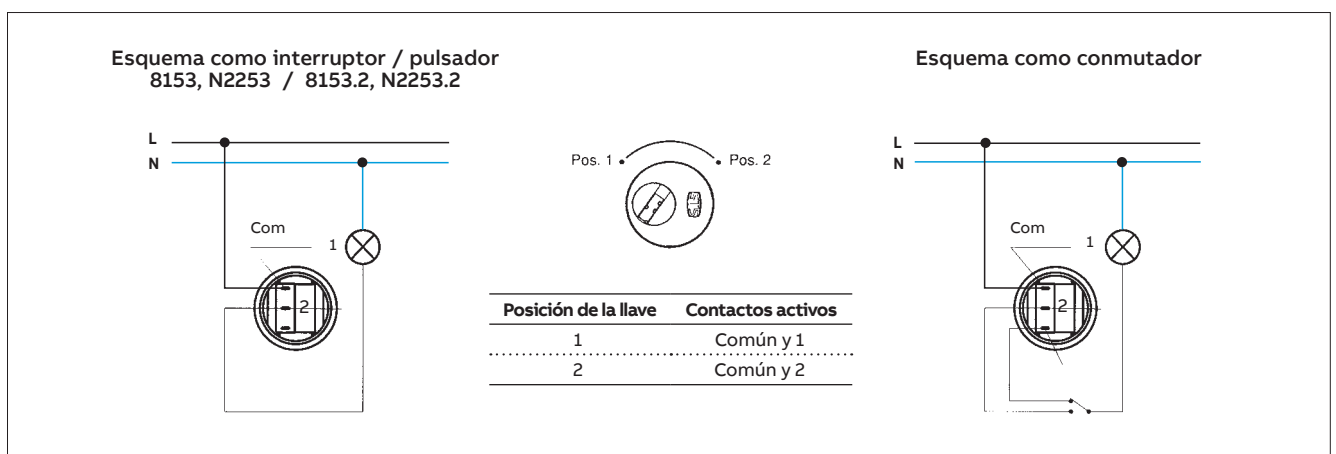

USB chargers

N2185, N2285 & N2185.2

1.- Technical data:

Rated input voltage:
100 - 240 V AC \pm 10 %

Rated input frequency:
50 - 60 Hz

Rated input current:
N2185.2: 0,20Aac@max load
N2285: 0,20Aac@max load
N2185: 0,12Aac@max load

Consumption in standby:
N2185.2: <10 mW@230 VAC
N2185 & N2285 : <= 0,3W@230 VAC

Rated output voltage:
5 V DC \pm 5 / -5 %

Rated output current:
N2185.2: 2000 mA a 5 V DC
N2285: 1500 mA a 5 V DC
N2185: 750 mA a 5 V DC

Operating temperature:
N2185.2: 0°C to 45°C, when installing
a N2185.2. 0°C to 30°C, when two
N2185.2 chargers together
N2285: 0° C + 35° C
N2185: 0° C + 45° C

Eficiencia energética:
N2185.2: > 79%
N2285: >= 71%
N2185: >= 66%

2.- Electrical safety data:

Safety standard:
EN60950-I - Low Voltage Directive

Protection class:
II - Low voltage

Isolation (primary-secondary):
Transformer with galvanised isolation

EMC Directive:
EN 55022, EN 55024

3.- Wiring diagram:

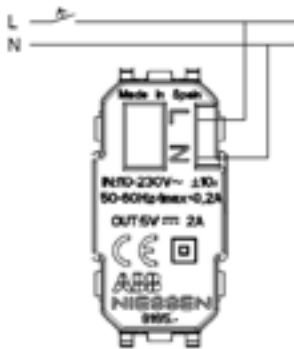

4.- Installation

N2185.2 & N2185

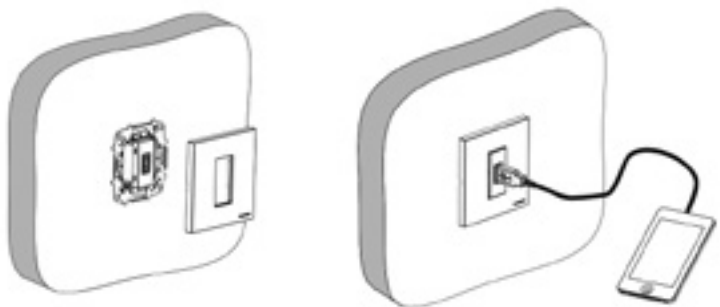
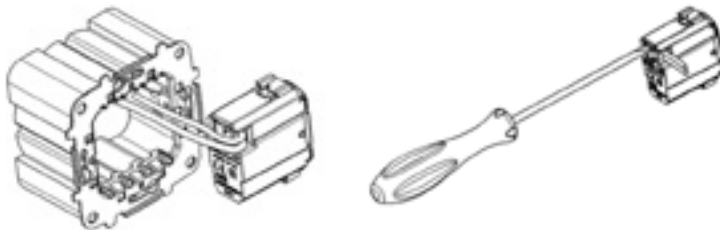

N2285

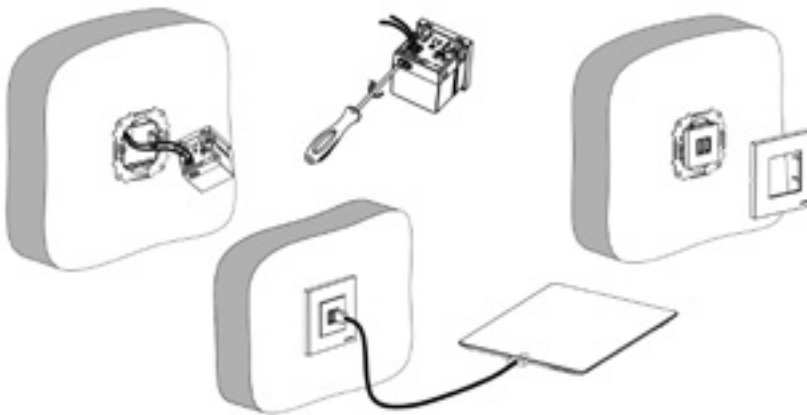

Circuit breaker 6/10/16A & RCD

N2234.1, N2234.2 & N2234.3

1.- Technical data:

Rated voltage:

120 - 230 Vac

Rated frequency:

50 - 60 Hz

Rated current (In):

N2234.1: 6 Aac

N2234.2: 10 Aac

N2234.3: 16 Aac

Breaking capacity:

N2234.1: 1,5 kA

N2234.2 & N2234.3: 3 kA

Residual current (sensitivity) - I Δ n:

10 mA

Magneto-thermic action:

C type (see diagram)

Number of poles:

Two-pole (1P + N) with 1 protected pole

2.- Standards:

EN 61009 / 1 / 1994

EN 61009 / 2 / 1 / 1994

IEC 1009 / 2 / 2 / 1991

IEC 1009 / 1 Amd 1 1995

Low Voltage Directive:

CEE 73/23 & 93/66 CEE

EMC Directive:

CEE89/336, 92/31 CEE & 93/68 EEC

3.- Wiring diagram:

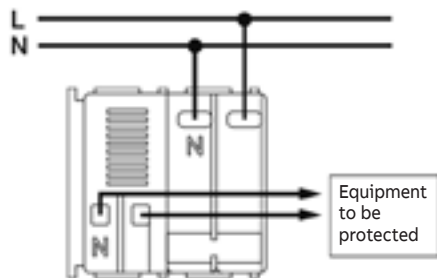

4.- Installation

1. Fix the plastic support in the mounting plate.
2. Insert the mechanism in the mounting plate from the rear side.
3. Place the cover plate.

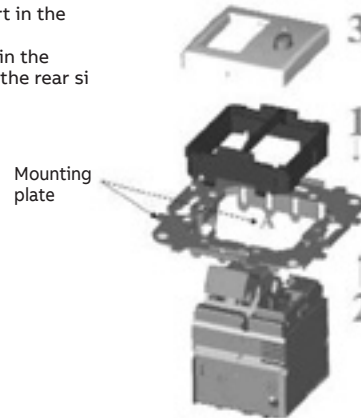

4.- Current-Time tripping diagram

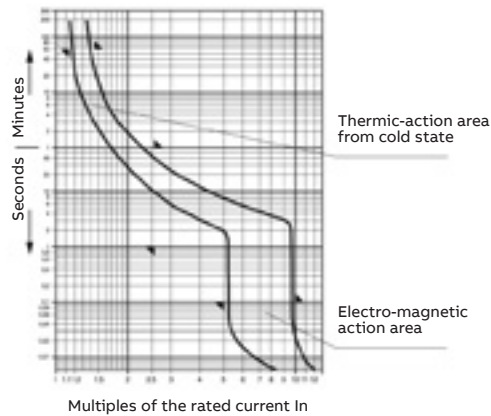

TV / R outlets

Technical data

- Connection: Screw terminal and clamp. Coaxial cable 75 ohm.
- Shielded zamak and metal plate chassis.
- In conformity with EN 50083-1:1993, EN 50083-2:2001, EN 61000-6-1:2001, EN 61000-4-2:1995 ESD 15KV AD, 8KV CD, EN50083-4:1998
- Fits in a Ø60 mm box.

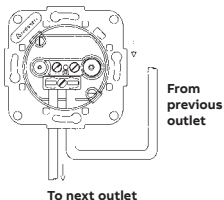

Important: the connection of the TV outlets in serial distribution must be carried out according to the figure on the left. The cable coming from the previous outlet is connected in the right terminal and the cable going to the next outlet in the left terminal.

Code			8150	8150.3	8150.7	8150.8
Installation			Final		Intermediate	
Connection			Screw terminal and clamp			
Output connectors		C1	IEC male Ø 9.52 mm			
		C2	IEC female Ø 9.52 mm			
Frequency range	MHz	I/O	5 - 862	5 - 862	13 - 862	5 - 862
		C1	5 - 862	5 - 862 / 118 - 862	13 - 862	5 - 862
		C2	5 - 862	87.5 - 108	13 - 862	5 - 862
Basic loss	dB ±TOL	FM	10,0 ±0,7	1,1 ±0,3	25,0 ±1,5	30,0 ±0,2
		DAB	10,0 ±1,5	R: 0,3 ±0,1	25,0 ±1,5	30,0 ±0,2
		VHF	4,0 ±1,5	TV: 0,9 ±0,3	8,0 ±0,7	11,0 ±1,0
		UHF	3,0 ±0,5	-	8,0 ±0,7	10,5 ±1,0
Through loss	dB ±TOL	FM	-	-	2,0 ±0,3	1,0 ±0,2
		VHF	-	-	2,0 ±0,5	1,1 ±0,3
		UHF	-	-	2,0 ±0,5	1,3 ±0,4
Directivity	dB	FM	-	-	>12	>25
		TV	-	-	>9	>13
Isolation	dB	FM	>14	>18	>16	>20
		TV	>14	>16	>15	>18
Return loss	dB	FM	>18	>16	>12	>18
		TV	>10	>18	>12	>15

Note: reference 8150.3 compatible with CATV

MATV connection diagram Distribution with tap-off units

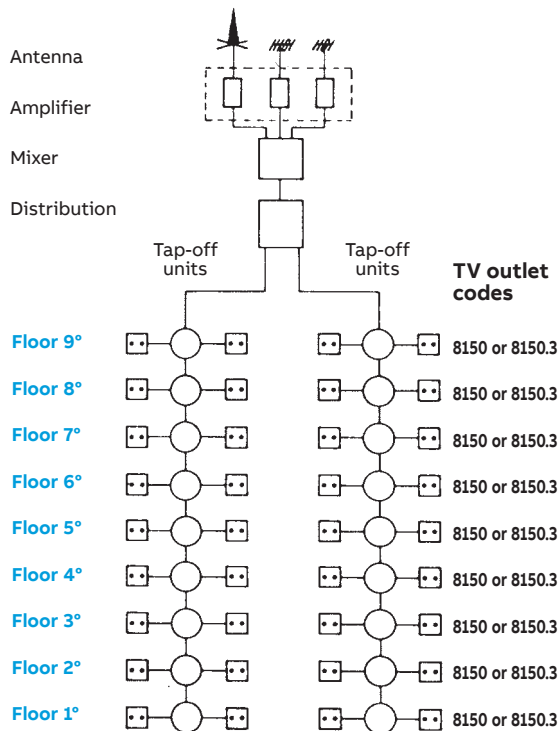

In this diagram all final outlets are the same. References 8150 or 8150.3 can be used equally.

MATV connection diagram Serial distribution up to 9 floors

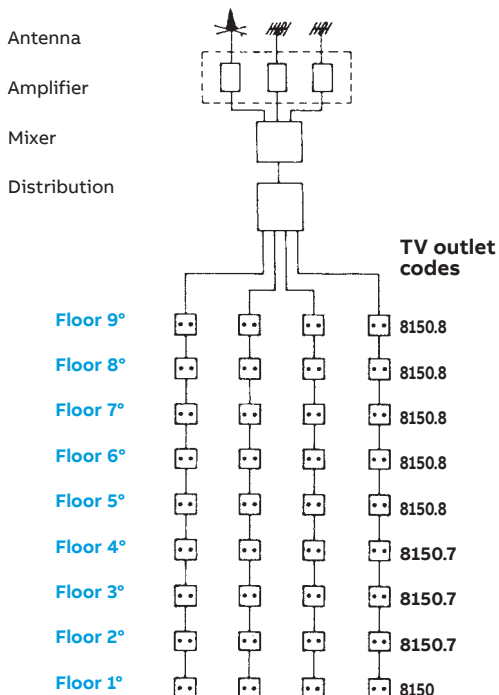

MATV connection diagram Serial distribution for more than 9 floors

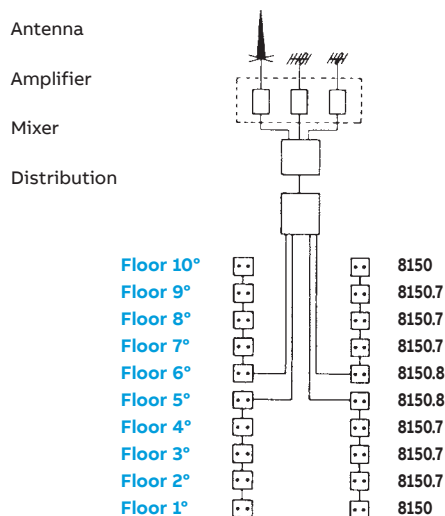

Example: 10 floors. The floors are divided in 2 groups of 5 floors each. The outlets are distributed according to the criteria shown in the MATV connection diagram for serial distribution up to 9 floors. The diagram above can be used in buildings up to 18 floors. For buildings with more than 18 floors and up to 27 floors, 3 groups have to be created and so on.

Tomas de TV-R / SAT

SMATV connection diagram

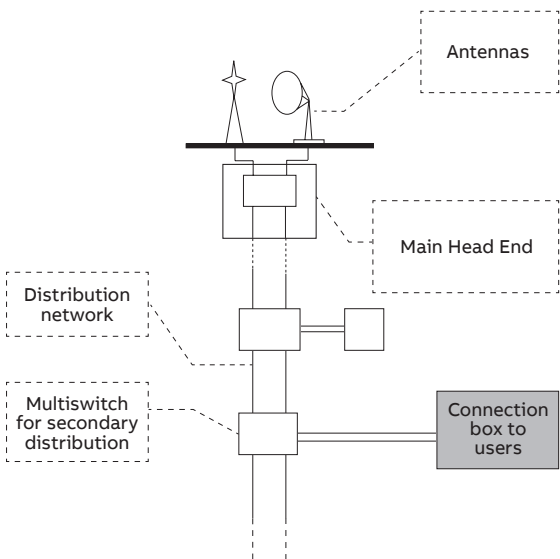

a) SMATV star connection diagram

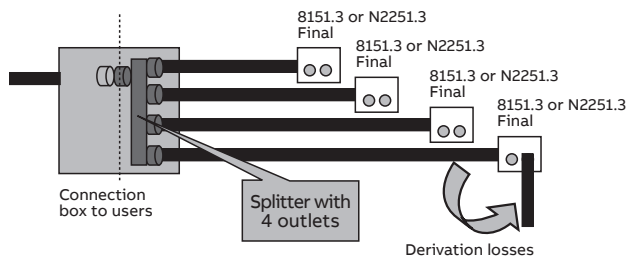

a) SMATV star connection diagram

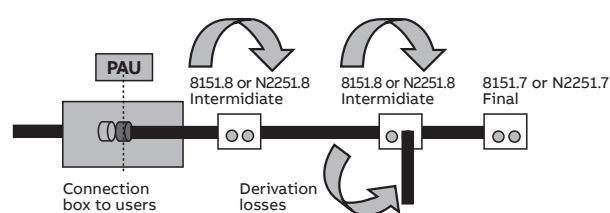

Note:

end of line impedance. If the distribution equipment requires outlets with end of line resistors, 8151.7/N2251.7 outlets must be used or add to 8151.3/N2251.3 outlets a termination resistor to close the line.

Note:

it is recommended to avoid installing more than 2 intermediate outlets per line.

Code			8151.3 N2251.3	8151.7 N2251.7	8151.8 N2251.8	8152.7
Installation			Final		Intermediate	Final
Connection			Screw terminal and clamp			
Output connectors		C1	IEC male Ø 9.52 mm			
		C2	IEC female Ø 9.52 mm			
		C3		-		F female
Frequency range	MHz	E/S	5 - 2400		5 - 2400	5 - 2500
		C1	5 - 862		5 - 2400	5 - 68 / 125 - 862
		C2	930 - 2400		5 - 2400	87,5 - 108
		C3			-	950 - 2500
Basic loss	dB ±TOL	FM	0,2 ±0,1	3,7 ±0,3	10,0 ±1,0	2,0
		TV	1,0 ±0,5	4,0 ±0,5	10,0 ±1,0	2,7
		SAT	1,2 ±0,6	5,0 ±1,2	12,0 ±2,0	2,3
Through loss	dB ±0,5	FM	-	-	2,5 ±0,5	-
		TV	-	-	2,5 ±0,7	-
		SAT	-	-	3,0 ±1,0	-
Directivity	dB	FM	-	-	>20,0	-
		TV	-	-	>12,0	-
		SAT	-	-	>5,0	-
Isolation	dB	FM	>45	>20	>45	>24,3
		TV	>14	>20	>30	>15
		SAT	>14	>14	>28	>15
Selectivity	dB	FM	-	-	-	>15
		TV-R	>15	-	-	>15
		SAT	>15	-	-	>15
Return loss	dB	VR	>25	>16	>13	>7,6
		FM	>25	>16	>13	>10
		TV	>14	>16	>12	>7,6
		SAT	>10	>9	>12	>8,2
DC path	V _{max}		24 max			24 max
	mA		500 max			500 max
	Tono		22 KHz/DiSEqC			22 KHz/DiSEqC

N2250.X & N2252 covers for TV outlets

1.- In some cases the TV outlets have too small holes for frame's clamps.

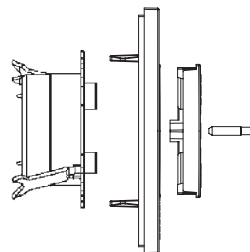
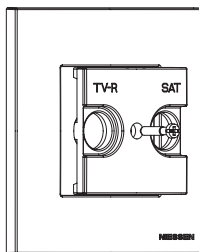
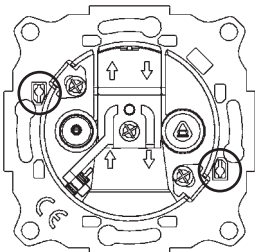

2.- To mount the cover plates there are 2 options: a) cut the clamps that are facing the small holes.

b) Cut all the clamps of the frame.

3.- When the cover plate is screwed to the insert, the 4 parts that stick out from the cover, will fix the frame to the wall.

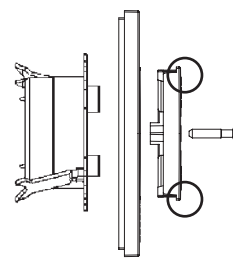
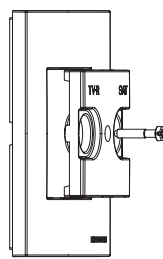
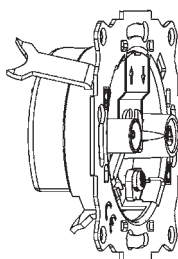
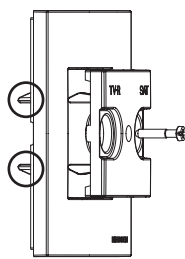
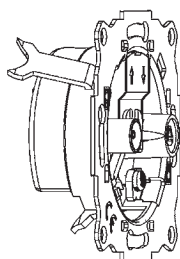

N2251.3 TV-R/SAT outlet single, N2251.7 TV-R/SAT outlet dead-end and N2251.8 TV-R/SAT outlet loop through

Mounting diagram

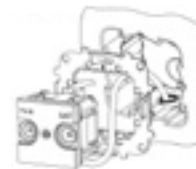
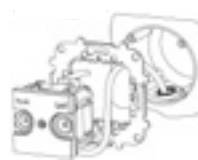
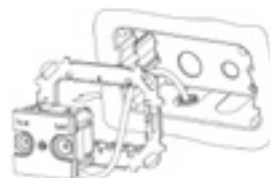
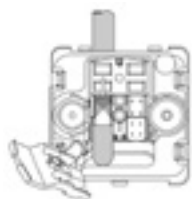

Cable to use

Cable to use

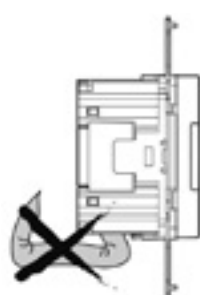
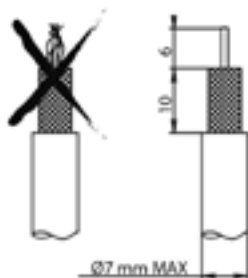

- Use coaxial cable with 75Ω impedance.

- Avoid small bending radius.

N2150.7 & N2250.7 - TV outlet dead-end

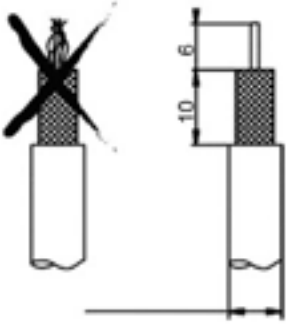
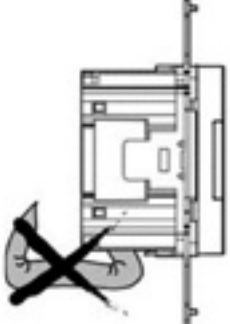
<p>Connector characteristics</p>  <p>N2150.7 N2250.7</p> <p>- TV output: 9,52 mm male.</p>	<p>Cable to use</p>  <p>- Use coaxial cable with 75Ω impedance.</p>	<p>Warning</p>  <p>- Avoid small bending radius.</p>
---	---	--

Name			TV outlet dead-end
Frequency range	MHz	TV	5 - 2400
Connection loss	dB	TV	1
Isolation	dB	TV	>16
Return loss	dB	TV	>7,6
Bypass DC current	V mA		34(máx.) 500(máx.) 22KHz / DiSEqC

Telephone outlets

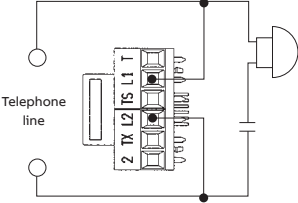
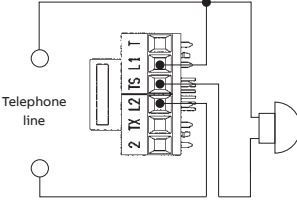
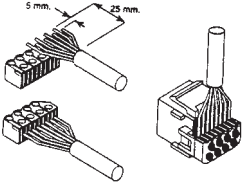
<p>6 contacts N2117.6 / N2217.6</p> <p>Additional bell with capacitor</p> 	<p>6 contacts N2117.6 / N2217.6</p> <p>Additional bell without capacitor</p> 	<p>8 contacts 2017.3</p> 
--	---	---

RJ45 Cat. 6 female connector

2018.6

1 Preparing the Cable

1.1 Cut approximately 5 cm. off the jacket.



1.2 Open approx. 10 cm. of the jacket with a cutter cord or another tool.



1.3 Cut the jacket.



1.4 Cut the mesh (if it has one and the cord at the same level of the jacket).



2 Preparing the Conductors

2.1 Select the adequate wiring scheme (568A or 568B) and place the pairs in a straight line.



Important Note:
Do not cross the pairs over one another!
First, arrange/position pairs 1 and 4, and then pairs 2 and 3 in their usual line.

568A	Az	Ma	Ve	Na
568B	Az	Ma	Na	Ve

2.2 Position each of the four pairs in the holes of the end piece.

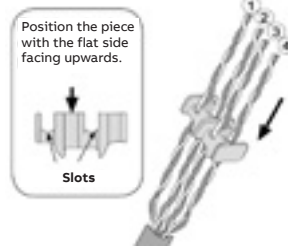

2.3 Ensure the end piece is located as close as possible to the edge of the jacket.

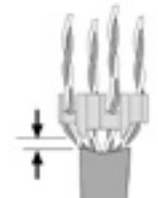

2.4 Place the pairs in the direction of the end piece slots.



2.5 Insert the end piece into the module.

Blue / White (first pair)

Check the orientation of the colour codes: Blue / White matched with Blue / White

Important Note:
Align the Blue / White pair with the Blue / White colour indicated in the module colour code.

Position the piece with the flat side facing upwards.

2.6 Unbraid the pairs, position and insert the cable in the module slots. Place the **solid colour cable in the first slot of the pair.**



The solid colour cable (Blue)

Cables and module ready.

3 Conductor Terminations

3.1 Place the tool perpendicular to the module and finish cutting the cables.

Place the cutting edge towards the module external side!

Note: Use a NORDX/CDT BIX AX100749, KRONE wiring tool, or a similar type 110 tool.

4 Placing the Cable

4.1 Place the cable in the upper, perpendicular, or lower position so that it is easy to insert the module in the box for attachment.

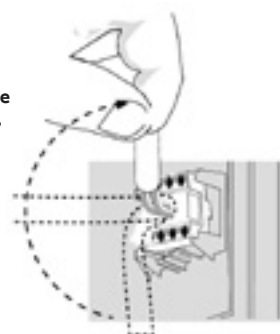

5 Disassembling the module from the supporting piece

5.1 Push the front of the module in with your thumb releasing the hooks.



5.2 Pry upwards to release the upper hook.



5.3 Pry downwards to release the lower hook.



RJ45 Cat. 5E female connector

2018.5

- 1** Remove the back cap from the connector. Strip approx. 5cm off the jacket and discard the cable cutter cord.

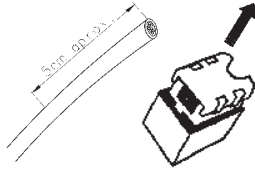

- 2** Bring the cable close to the connector, with the jacket at approx. 6 mm from the connector. Insert the cables into the corresponding slots as indicated by the cable colour-wiring configuration for T568A or T568 B (as shown in Figures 2A and 2B).

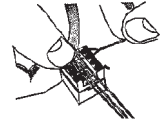

- 2a** Wiring according to T568A:

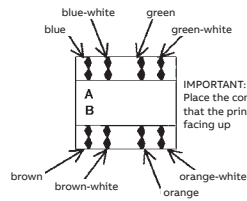

- 2b** Wiring according to T568B:

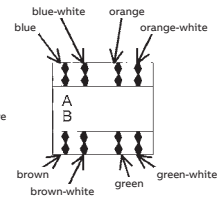

IMPORTANT:
Place the connector in such a way that the printed letters A and B are facing up

- 3** Push the cables against the end of the slot and cut them flush to the connector. Use an IBDN 110, BIX, KRONE wiring tool, or a similar type 110 tool.

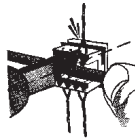

- 4** Mount the connector cap.



VDI connectors

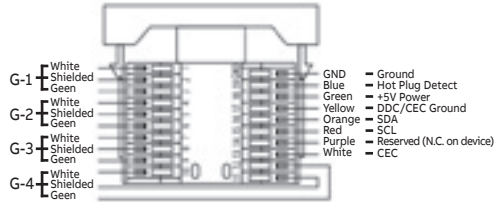
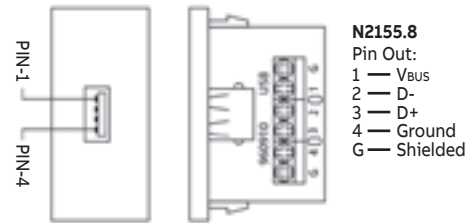
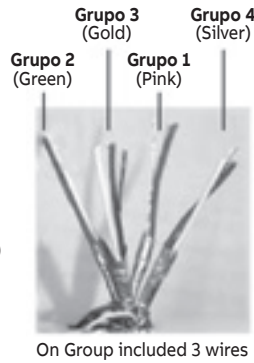
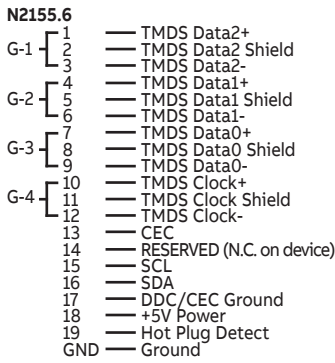
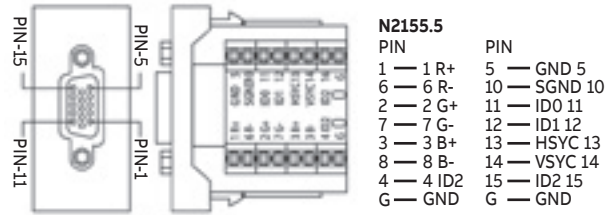
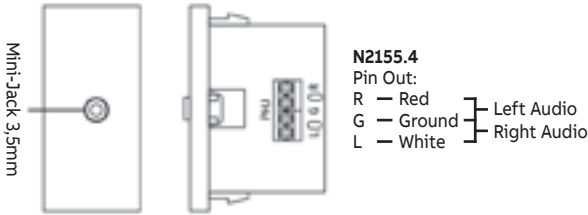
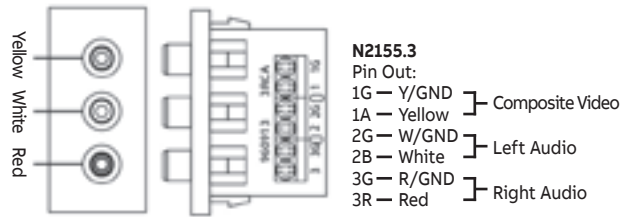
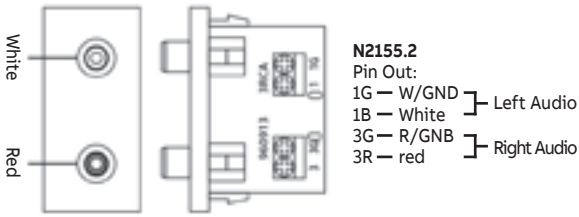

Note:
 Using a strap for fixing the cable to the board it is recommended to avoid disconnections. For this the plates have two through-holes at its rear end.

Rotary/push dimmer - N2260.2

1.- Technical data

Electrical data:

- Power supply: 230 V~ ; 50 Hz
- Minimum power: 60 W / VA
- Maximum power:
500 W incandescent lamps.
500 VA halogen lamps with electronic transformer.
400 VA halogen lamps with ferromagnetic transformer.
- Room temperature for operation: 0 to 30 °C.

Features:

- Dimming control by means of a local push button (N2260.1 and N2260.2) and a dimmer switch (N2260.2).
- Control capability through auxiliary push buttons (N2X04.X).
- LED indicator pilot.

Detecting the type of load

- After wiring the device to the power supply, the dimmer assesses the type of the load connected.

Overload

- If the device overloads above the maximum rated power, or if the operating temperature exceeds the maximum, the regulator will automatically stop working as a safety measure.

Short Circuit

In case of short circuit, the device will stop working as a safety measure.

Note: Disconnect the device from the power supply if you are making changes to the load.

2.- Assembly/Connection

2.1.- Connection

Important: disconnect the power supply when installing.

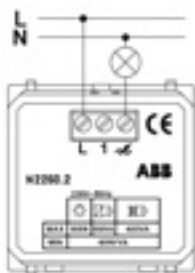

Figure 1:
Basic wiring diagram

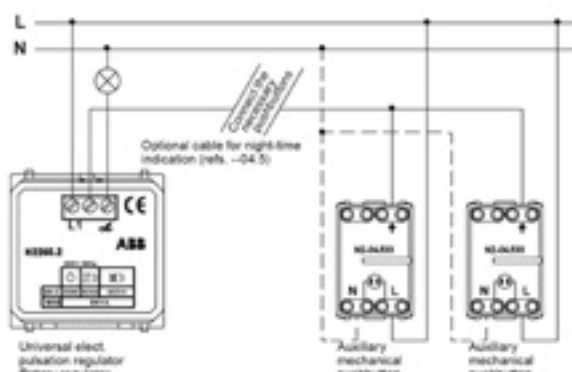

Figure 2: Special wiring diagram

Wiring for direct control

The electrical wiring for these devices is performed according to the wiring diagram shown in Figure 1.

The terminal marked "L" shows the phase wire of the installation.

The terminal indicated with \overline{N} represents the conductor wiring terminal returning from the load, which is also connected to the neutral conductor of the installation. See Figure 1.

The terminal marked "1" is used to exercise control from several points by means of conventional push buttons. See Figure 2.

If the device is installed individually, follow the instructions indicated in Figure 1.

Wiring for remote control option

The special characteristics of these dimmers enable the remote control using conventional auxiliary push buttons (N2X04.X), making it possible to control the turning on and off and dimming features from different points using only one electronic dimmer and any number of conventional push buttons as desired.

In case it is required to exercise control from several points, refer to the diagram below. Any number of auxiliary conventional push buttons may be used as needed.

The outputs of these push buttons are connected to terminal "1". See Figure 2.

Note: pay special attention to the device input and output conductors, according to the previous description.

3.- Mounting

To install the device follow these steps:

1. Connect the device based on the corresponding wiring scheme. Figure 1 and Figure 2.
2. Mount the device on the wall box.
3. Then, position the plate.

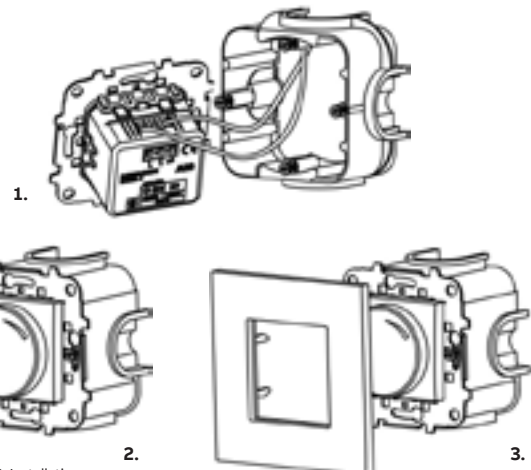

Figure 3: Installation

4.- Operation

The operation of the dimmer during the set up, disconnection or regulation is as follows:

Short pulsation

If the dimmer is off, upon receiving a short pulsation it will turn on using always the maximum level of light.

If the dimmer is on, upon receiving a short pulsation it will turn off.

A short pulsation refers to any pulsation lasting between 50 ms and 400 ms.

Long pulsation

If the dimmer is off, upon receiving a long pulsation it will turn on using the minimum level of light. Then it will increase it until the pulsation stops, or until it reaches the maximum level of light.

If the dimmer is on, upon receiving a long pulsation the dimming direction will reverse: if the level of light has increased up to a certain point, it will diminish, and vice versa. Whenever the maximum (or minimum) level of light is reached during a long pulsation, the dimming will stop in the maximum (or minimum) level, even if pulsation continues.

A long pulsation refers to any pulsation lasting for more than 400 ms.

Turning the knob clock-wise:

- If the load is off, or in the maximum intensity level, it will not perform any action.
- If the load is in a specific dimming point, it will increase the load intensity.

Turning the knob anti-clockwise:

- If the load is off, it will not perform any action.
- If the load is in a specific dimming point, or in the maximum level, it will diminish the load intensity.

Once the load reaches the maximum or minimum intensity level, if we keep turning the knob anti-clockwise or clockwise, the load will continue in its maximum/minimum intensity level.

Rotary LED dimmer

N2260.3 & N2260.8

1.- Technical data

Rated voltage / max. power:

- N2260.3: 230 V~ ±10%, 50 Hz / 250 W/VA
230 V~ ±10%, 60 Hz / 200 W/VA
- N2260.8: 127 V~ ±10%, 60 Hz / 140 W/VA
- Room temperature for operation: 0 to 35 °C.

Protection:

- Back-up fuse: Electronic
- Overload protection: Electronic

N2260.3 - Rated min./max. power (230 V~):

- LEDi: 2 W/VA / 100W/VA (máx. 10 lamps).
- Dimmable energy saving lamps: 2 W/VA / 100W/VA (máx. 10 lamps).
- LV LEDi with transformer: 4 W/VA / 100W/VA (máx. 10 lamps).
- Incandescent lamps: 10 W/VA / 250W/VA.
- Halogen lamps: 10 W/VA / 250W/VA.
- LV halogen lamps with transformer: 10 W/VA / 250W/VA.

N2260.8 - Rated min./max. power (127 V~):

- LEDi: 2 W/VA / 55W/VA (máx. 10 lamps).
- Dimmable energy saving lamps: 2 W/VA / 55W/VA (máx. 10 lamps).
- LV LEDi with transformer: 4 W/VA / 55W/VA (máx. 10 lamps).
- Incandescent lamps: 10 W/VA / 140W/VA.
- Halogen lamps: 10 W/VA / 140W/VA.
- LV halogen lamps with transformer: 10 W/VA / 140W/VA.

2.- Wiring diagram

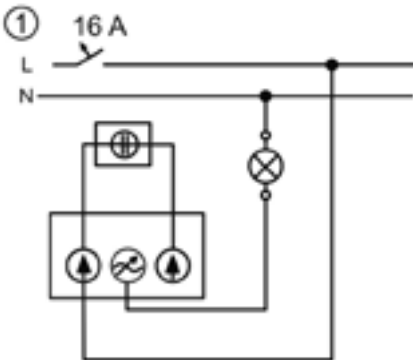

Standard operation

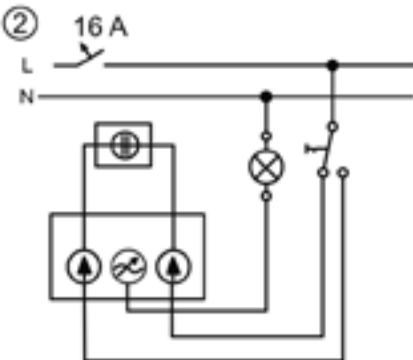

Operation in a two-way circuit

Warning:

Disconnect the mains power supply prior to installation and/or disassembly! Permit work on the 230V/127V supply system to be performed only by specialist staff.

3.- Mounting

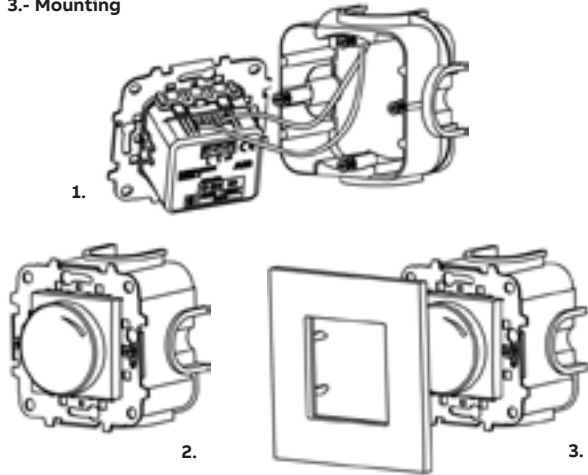

Turn the device in the correct installation position. The marks on the back side of the device, orient the correct top position.

4.- Set-up

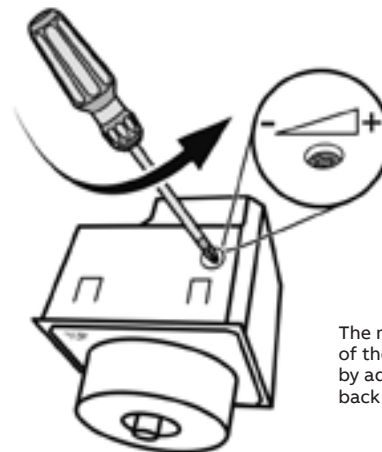

The minimum brightness of the dimmer can be set by adjusting the on the back side of the device..

5.- Operation

The LED dimmer is a phase-angle dimmer and is used to switch and dim all lamps listed in "Types of load", especially LEDi loads (LED lamps with an integrated ballast). The LED dimmer serves as light controller in connection with rotary dimmer control elements.

Notes:

1) Use only L or LC transformers. Pure C transformers are not permitted. If transformers are used, the specifications of the respective manufacturers must be observed. In particular, observe the information regarding the minimum load.

Connection load for LEDi

2) Above a connection load of 25 W/VA, suitable measures must be taken to increase the connection load to a maximum of 100 W/VA (230 V supply) or 55 W/VA (127 V supply) when connecting LEDi according to IEC 61000-3-2, for example, through the use of harmonic wave filters.

3) Maximum number of LEDi lamps is 10.

Rotary dimmer 1-10 Vdc for fluorescen or LED drivers

N2260.9

1.- Technical data

- Power supply:
230V 50-60Hz 700VA
127V 50-60Hz 350VA
- Load type: Dimmable electronic ballast with 1-10V control input.

2.- Assembly/Connection

2.1.- Connection

Follow the steps below to install the mechanism:

1. Connect the device according to the connection schemes. Figure 2 and Figure 3.
2. Assemble the device on the flush mounting box.
3. Then, place the plate.

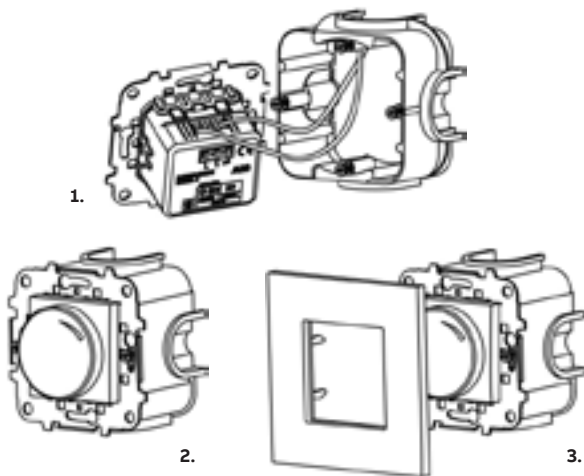

Figure 1: Installation

Important: Disconnect the power supply when installing.

2.- Connection

The fluorescent lighting dimmer N2260.9 may be connected to dimmable electronic ballasts with a control input of 1-10 V as shown in Figure 2:

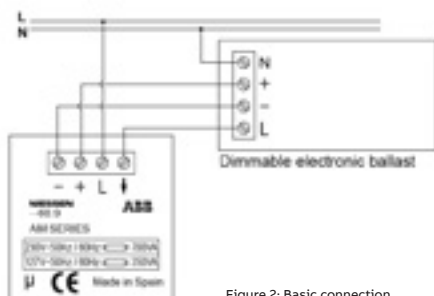

Figure 2: Basic connection

The maximum charge to be connected to the control terminals +/- should not exceed 50 mA.

See technical specifications of the dimmable electronic ballast to be installed.

Electronic ballasts generate a very high instantaneous peak current at connection, therefore it is recommended not to connect more than 6 ballasts to the N2260.9 fluorescence regulator.

In installations where it is required to connect more than 6 electronic ballasts to the same regulator mechanism, it is recommended to use a contactor to protect the mechanism contacts. See Figure 3.

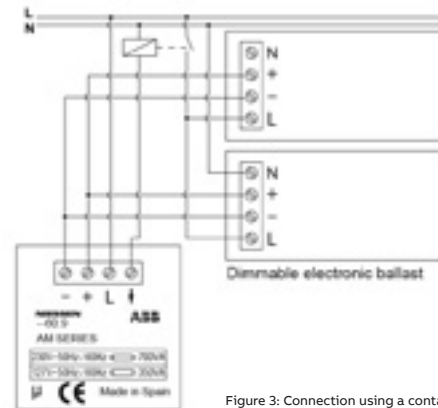

Figure 3: Connection using a contactor

3.- Operation button turns in the clockwise direction

If the charge is disconnected, i.e. the rotatory button is completely turned counter-clockwise, when turning right the charge will turn on (a "click" will be heard) and the intensity level will increase as we turn the button in the clockwise direction.

If the charge is at a given point of regulation, the charge intensity will increase as we turn the button in that direction.

If we turn the button completely in the clockwise direction, this will stop in a limit, which will coincide with the maximum regulation intensity level.

Operation button turns in the counter-clockwise direction

Intensity level will reduce as we turn the button in the counter-clockwise direction.

If we turn the button completely in the counter-clockwise direction, a "click" will be heard and the button will stop in a limit, the charge will be disconnected.

1 Module dimmer - N2160.E

1.- Technical Data

Voltage:
 N2160: 127 V~ ; 60 Hz
 N2160.1: 230 V~ ; 50-60 Hz

Power:
 N2160: 50-500 W ⚡
 N2160.1: 50-700 W ⚡

Operating temperature:
 0 – 30° C

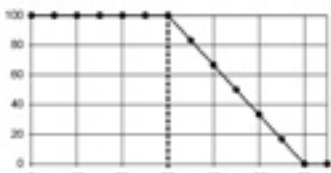
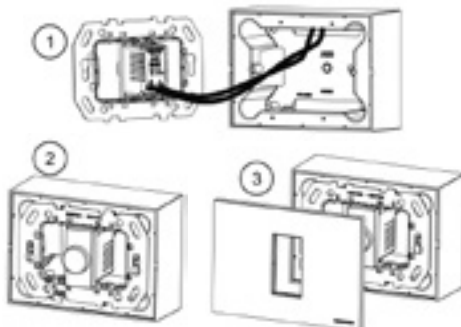

Table 1: Power reduction (%) as a function of temperature (°C)

2.- Assembly/Connection

2.1.- Assembly

Important:
 If the dimmer is installed next to another electronic device that can produce heat, the maximum power must be reduced in half. If it is installed between two electronic devices that can produce heat, the maximum power must be reduced to the fourth.



2.2.- Connection

Important:
 Disconnect the power supply when installing.

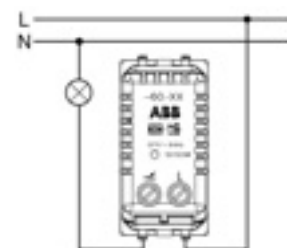

3.- Operation

Do not exceed the maximum shown in Table 1, since the dimmer has a NON-resettable thermal fuse. If the fuse is triggered, the electronic dimmer is useless for further use. In case of exceeding the maximum load, the fuse could not trig but it may happen that the load will not turn off.

Push dimmer - N2260

1.- Technical Data

Power supply:
 127 V~ ; 60 Hz / 230 V~ ; 50 Hz

Minimum power:
 40 W / VA

Maximum power:
For 230 V~ ; 50 Hz:
 ⚡ 450 W incandescent lamps.
 ⚡ 400 VA halogen lamps with transformers.

For 127 V~ ; 60 Hz:
 ⚡ 250 W incandescent lamps.
 ⚡ 250 VA halogen lamps with transformers.

Protection against overcurrent:
 Using a calibrated fuse ref. T-2A.

Protection against faulty connections:
 Using an electronic device.

Regulation time: from minimum to 3.8 secs.

Nighttime indicator display: LED.

Temperature for operation: 0 to 30 °C.

Interference suppression:
 UNE-21806 and EN 55014 Standards.

3.- Mounting:

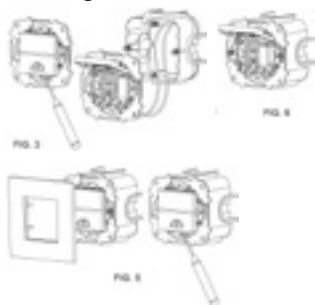

- To connect the device, lift the switch (Fig. 3).
- Connect the dimmer based on the wiring scheme (Figs. 1 and 2).
- Mount the device on the wall box, and then position the plate.
- To change the fuse, lift the switch, pulling softly along its edge (Fig. 5) and remove the fuse holder (Fig. 6).

2.- Wiring diagram:

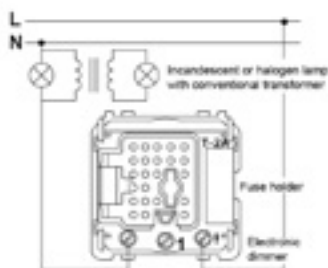

Figure 1

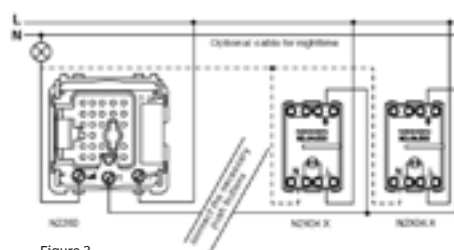

Figure 2

The electrical wiring for these devices is performed according to the wiring diagram shown in Figure 1. The incoming arrow indicates the phase/line wire of the installation and the outgoing arrow indicates the wiring towards the receptor/load according to Figure 1. The terminal "1" is used to enable the remote control from several points using conventional pushbuttons, refer to the Figure 2. If the device is to be installed individually, follow the instructions indicated in Figure 1.

This dimmer allows the remote control using conventional auxiliary pushbuttons, making it possible to control the turning on and off and dimming features from different points by means of only one electronic device and any number of conventional pushbuttons as desired. In case it is required to allow control from several points, refer to the Figure 2. Any number of auxiliary conventional pushbuttons may be used as needed. The outputs of these pushbuttons are connected to terminal "1". See Figure 2.

NOTE: Pay special attention to the device input and output conductors, according to the previous description.
Make sure to disconnect the power supply before manipulating the device.

4.- Operation:

The operation of the regulator during set up, disconnection or regulation is as follows:

SHORT PULSATION:

If the regulator is off, upon receiving a short pulsation it will turn on using always the maximum level of light.

If the regulator is on, upon receiving a short pulsation it will turn off.

A short pulsation refers to any pulsation lasting between 50 ms and 400 ms.

LONG PULSATION:

If the regulator is off, upon receiving a long pulsation it will turn on using the minimum level of light; then it will increase it until the pulsation stops, or until it reaches the maximum level of light. If the regulator is on, upon receiving a long pulsation the regulation direction will reverse: if the level of light has increased up to a certain point, it will diminish, and vice versa. Whenever the maximum level of light is reached during a long pulsation, the regulation will stop in the maximum level, even if pulsation continues. However, when the minimum level is reached, it does not stop and it starts increasing.

A long pulsation refers to any pulsation lasting for more than 400 ms.

Universal pulsation dimmer - N2260.1

1.- Technical data

Electrical data:

- Power supply: 230 V~ ; 50 Hz
- Minimum power: 60 W / VA
- Maximum power:
500 W incandescent lamps.
500 VA halogen lamps with electronic transformer.
400 VA halogen lamps with ferromagnetic transformer.
- Room temperature for operation: 0 to 30 °C.

Features:

- Dimming control by means of a local push button (N2260.1 and N2260.2) and a rotary dimmer (N2260.2).
- Control capability through auxiliary push buttons (N2X04.X).
- LED indicator pilot.

Detecting the type of load

- After wiring the device to the power supply, the dimmer assesses the type of the load connected.

Overload

- If the device overloads above the maximum rated power, or if the operating temperature exceeds the maximum, the regulator will automatically stop working as a safety measure.

Short Circuit

In case of short circuit, the device will stop working as a safety measure.

Note: Disconnect the device from the power supply if you are making changes to the load.

2.- Assembly/Connection

2.1.- Connection

Important: disconnect the power supply when installing.

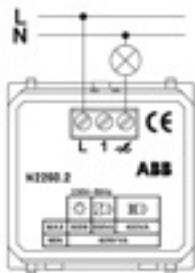

Figure 1:
Basic wiring diagram

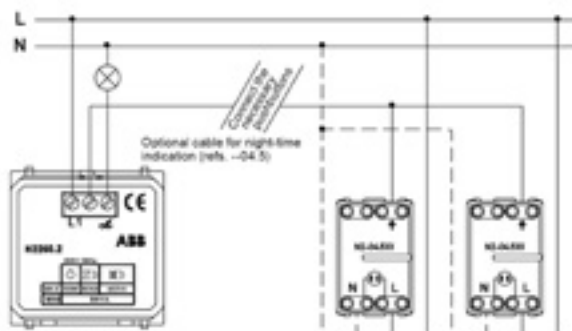

Figure 2: Special wiring diagram

Wiring for direct control

The electrical wiring for these devices is performed according to the wiring diagram shown in Figure 1.

The terminal marked "L" shows the phase wire of the installation.

The terminal indicated with \neq represents the conductor wiring terminal returning from the load, which is also connected to the neutral conductor of the installation. See Figure 1.

The terminal marked "1" is used to exercise control from several points by means of conventional push buttons. See Figure 2.

If the device is installed individually, follow the instructions indicated in Figure 1.

Wiring for remote control option

The special characteristics of these dimmers enable the remote control using conventional auxiliary push buttons (N2X04.X), making it possible to control the turning on and off and dimming features from different points using only one electronic dimmer and any number of conventional push buttons as desired.

In case it is required to exercise control from several points, refer to the diagram below. Any number of auxiliary conventional push buttons may be used as needed.

The outputs of these push buttons are connected to terminal "1". See Figure 2.

Note: pay special attention to the device input and output conductors, according to the previous description.

3.- Mounting

To install the device follow these steps:

1. Connect the device based on the corresponding wiring scheme. Figure 1 and Figure 2.
2. Mount the device on the wall box.
3. Then, position the plate.

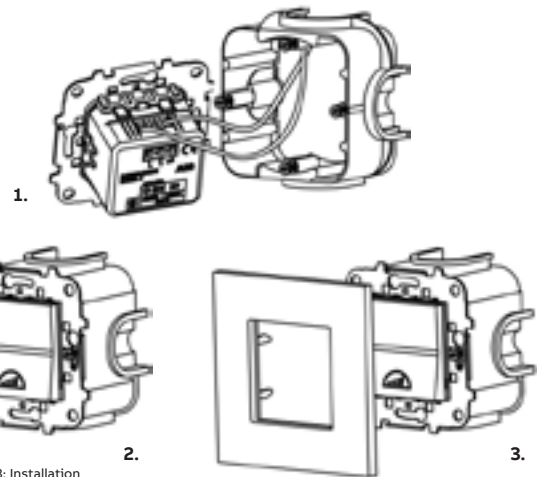

Figure 3: Installation

4.- Operation

The operation of the dimmer during the set up, disconnection or regulation is as follows:

Short pulsation

If the dimmer is off, upon receiving a short pulsation it will turn on using always the maximum level of light.

If the dimmer is on, upon receiving a short pulsation it will turn off.

A short pulsation refers to any pulsation lasting between 50 ms and 400 ms.

Long pulsation

If the dimmer is off, upon receiving a long pulsation it will turn on using the minimum level of light. Then it will increase it until the pulsation stops, or until it reaches the maximum level of light.

If the dimmer is on, upon receiving a long pulsation the dimming direction will reverse: if the level of light has increased up to a certain point, it will diminish, and vice versa. Whenever the maximum (or minimum) level of light is reached during a long pulsation, the dimming will stop in the maximum (or minimum) level, even if pulsation continues.

A long pulsation refers to any pulsation lasting for more than 400 ms.

Movement detector - N2241

1.- Introduction

This motion detector device senses the movement of people in an area of 5m (maximum) and in a 110° angle. Depending on the level of light detected by the light sensor and the motion detected in the covered area, the device determines if the load connected to it should be activated or not, thus lighting the area in which it is connected whenever someone passes. While it is detecting movement, the device maintains the load activated. When it stops detecting motion it disconnects the loads in the preset time. The device enables remote control through conventional push buttons with the use of only one conductor and thus simplifying electrical installations with the possibility to substitute the traditional switched installations.

2.- Technical Characteristics:

Power supply: 230 V~ ; 50 Hz
127 V~ ; 60 Hz

Maximum power:

- Incandescent lamps: 1,800 W (230 V~ 50 Hz)
1,000 W (127 V~ 60 Hz)
- Halogen lamps with electronic transformer, or halogen lamps with ferromagnetic transformer:
750 VA (230 V~ ; 50 Hz)
400 VA (127 V~ ; 60 Hz)
- Fluorescent lamps or motors: 400 VA (230 V~ ; 50 Hz)
200 VA (127 V~ ; 60 Hz)

Voltage free relay output: 2 terminals:

- Control capability through auxiliary push buttons (N2X04.X).
- Timer adjustment: Between 10 sec. and 10 minutes.
- Adjustment of light set point level for detection.
- Room temperature for operation: -10° C to 40° C.
- Detection range of the IR motion sensor: Max. 5 metres in a 110° angle.

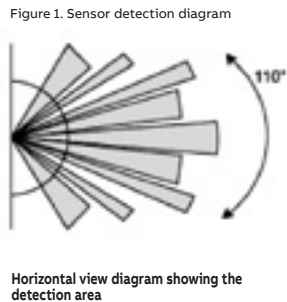
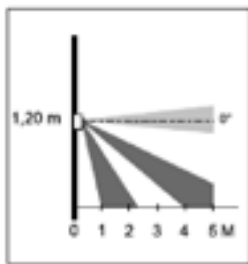
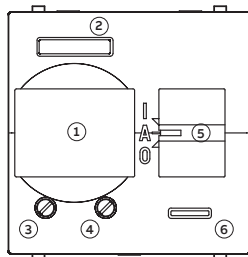

Figure 1: Sensor detection diagram

Figure 1: Horizontal view diagram showing the detection area

Front device description



- 1.- Detection lens
- 2.- Light sensor
- 3.- Light set point selector
- 4.- Timer selector
- 5.- Operating mode selector (3 positions):
I – Always on
A – Automatic (central position)
0 – Always off
- 6.- Red LED, indicator of automatic operating mode. It does not light when operating in modes I and 0.

Fig 2.- Front view of the device

3.- Wiring

Pre-installation recommendations

Install the device away from heat sources or draughts. The sensitivity of this detection device depends on several factors such as temperature, ambient humidity, as well as speed and direction of people's movement. Before installing the device, it is important to determine where to install it so that it adequately covers the desired detection area.

Basic wiring

The electrical wiring of these devices is performed according to the wiring diagram shown in Figure 3. The terminal marked "L" shows the phase wire of the installation. The terminal marked "N" shows the neutral wire of the installation. The terminals marked "A" and "L" represent the two terminals of the relay output (voltage free).

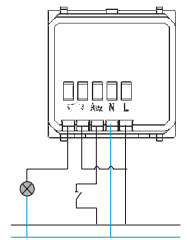

Figure 3: Basic wiring diagram

The terminal marked "aux" (control terminal) is used in case it is desired to control the device (optional) from different points through conventional push buttons (auxiliary pushbuttons). See wiring diagram in Figure 4. It is possible to use the device as a crepuscular switch if a switch is connected to the control terminal to a pushbutton.

Note: Pay special attention to the device input and output conductors, according to the previous description. Make sure to disconnect the power supply before manipulating the device.

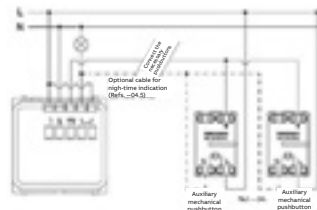

Figure 4: Special wiring diagram

Wiring of several devices in parallel

The detection area in a zone can be increased by installing more than one motion detector device. To ensure that the detection of movement by any of the devices installed activates the load controlled by all of them, their outputs should be wired in parallel to the load. See wiring diagram in Figure 5.

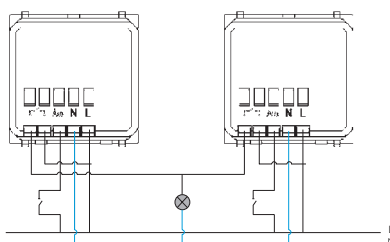

Figure 5: Parallel wiring diagram

Selection of the light and time threshold

Once the device is wired and installed, based on the type of application, it is important to determine the light value below which the device should activate the load while in Automatic Mode, either by the detection of movement or by pressing the auxiliary pushbutton. The light set point selector (see Figure 6) enables the selection of the light threshold below which the detector will activate the load. - If the potentiometer is turned to the left (anti-clockwise), the device will activate the load whenever it detects movement, regardless of the light value, during either day or night. -If, on the contrary, the potentiometer is turned to the right (clockwise), the device will activate the load when it detects movements under low light conditions, i.e. almost in the dark.

Movement detector - N2241



Figure 6: Exploded view of the selection potentiometers for the selection of light and time thresholds.

The load disconnection time is another important parameter that needs to be chosen. The set value will be based primarily on the type of application and the detector installed. The time can be chosen easily by turning the time selector potentiometer (see Figure 6).

4.- Installation

To install the device follow these steps:

1. Connect the device based on the wiring scheme. Figures 3, 4 and 5.
2. Mount the device on the wall box.
3. Then, position the plate.



Figure 7: Installation for N2241

The load disconnection time is another important parameter that needs to be chosen. The set value will be based primarily on the type of application and the area in which the detector is installed. The time can be chosen easily by turning the time selector potentiometer (see Figure 6).

6.- Operation

The motion detector device has 3 different operating modes that the user can select at any time using the selector located at the front of the device.

The available operating modes are the following:

- I – Always on
- A – Automatic (central position)
- O – Always off

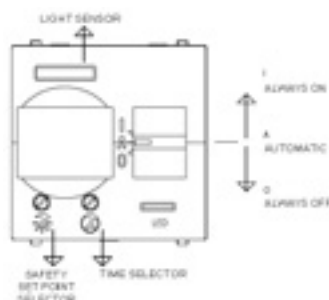

Operating Mode "I": Always On

How to select the operating mode "Always On"

- The operating selector is in position I: Always On
- The front red pilot is off

In this operating mode, the load is always activated, regardless of the light

level or the movement detected within the covered area.

While in this mode, the device does not respond to the auxiliary push button that may be connected to the control terminal.

Operating Mode: Automatic (A). Motion detector.

How to select the operating mode "Automatic"

- The operating selector is in position A: Automatic.
- The device indicates it is in the Automatic operating mode by lighting the front red pilot.
- Optionally, the auxiliary push buttons wired to the control terminal can be used.

This operating mode enables the independent activation and deactivation of the load, based on the movement detected within the covered area and on whether the light level is above or below the set threshold.

When the device detects movement of people and the light level sensed is below the set point, then it activates the load. With the conditions described above and while the device detects movement, the load will be activated.

Once the device stops detecting movement, it will deactivate the load based on the time set for deactivation; in this way, the device will be on standby until it detects another movement within the covered area.

When one of the auxiliary push buttons that may be connected to the control terminal is pushed, the device will behave as if it had detected movement. It will activate the load whenever the light level in the covered area is below the set point and will deactivate the load if no movement is detected within the time set.

Operation as Crepuscular Switch

The device can be operated as a crepuscular switch, i.e. it can activate the load when the light level is below the set threshold, no matter if there are people moving in the area or not. In the same way, the device may deactivate the load when the light level goes above the selected threshold.

How to select the operating mode "Automatic" when the device works as a crepuscular switch.

- The operating selector is in position A: Automatic
- The device indicates it is in the Automatic operating mode by lighting the front red pilot.
- Instead of using auxiliary push buttons, wire a switch to the control terminal and then, wire the terminal to the phase wire. When the switch is closed, the device operates as a crepuscular switch.

This operating mode is a well defined application derived from the device Automatic operating mode. In this mode, the device operates as a crepuscular switch, so that when the front light sensor detects a decrease in the light level below the set threshold, the switch activates the load, regardless whether there is movement of people or not within the covered area.

Once the light in the room collected by the sensor exceeds the set light threshold, it disconnects the load.

Note 1: For the correct operation of the device as a crepuscular switch, the device should be kept away from the light source (load) it controls. In this way, the purpose is that the device's light sensor only collects the room light (not artificial) that will determine if the light loads automatically controlled by the device should be turned on or off.

Note 2: This operating mode automatically decides whether to connect or disconnect the loads, based solely on the light collected by the device's light sensor. Therefore, the operation of the device does not rely on or respond to the movement of people within the covered area, if the switch connected to the control terminal is closed to the phase wire.

Time delay switch

N2262.1

1.- Technical data

- Rated Voltage: 230 V~ ; 50 Hz

- Maximum power:

☀ 40 - 500 W for incandescent lamps.

⚡ 40 - 400 VA for halogens with conventional transformers.

Ⓜ 40 - 100 VA for motors.

Protection against overcurrents:

Through calibrated fuse F-3,15H. It is supplied with a replacement.

Protection against faulty connections:

Through electronic device.

Time delay: from 10 sec. to 10 min. ($\pm 10\%$).

Night vision device: red LED.

Operating temperature: from 0 to 40 °C.

2.- Wiring diagram:

The electric connection of these articles is carried out in conformity with the presentation of the following Figures. The «L» terminal indicates the connection with the installation phase wire, and the arrow exiting the device indicates the connection to the receptor.

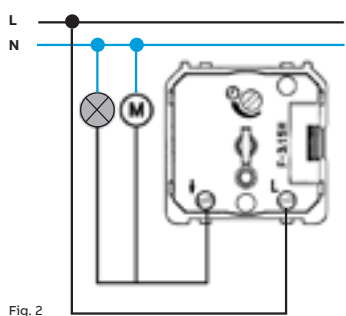
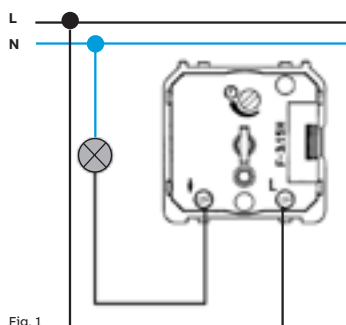

NOTE:

Pay particular attention to the connection of exit/entry device conductors, as shown in the diagrams.

When manipulating the device, make sure it is disconnected from the power grid.

For the applications requiring the timing of an engine of less than 40VA power, for example a small air-extractor engine with 13VA in a bathroom, the connection will be possible if you connect another load to the latter, so as to make sure the addition of both power loads results in a power output which is greater than 40VA, the minimum load required for the correct operation of the device.

If an engine is connected to another load (a halogen or incandescent lamp), the maximum power load of the latter has to equal the maximum power output value of the engine.

3.- Mounting:

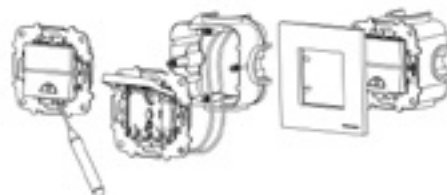

1. Connect the device according to the instructions cited in the subsection on connection grid systems. Do not manipulate the device when connected to the power grid.
2. Introduce the mechanism in the flush-mounting box holding it with the screws of the box (or with fixation claws, if the box is equipped with them).
3. Set the time delay.
4. Mount the frame.
5. When mounting the other series, insert the frame between the support and the body and screw the support to the body. Mount the key on the support.
6. The time delayed switch is ready to use.

4.- Operation:

The time delayed switch is an electronic operation mechanism making the automatic disconnection of the controlled element, within an adjustable time interval.

The manual operation is carried out by pressing the key.

Setting the desired time margin for disconnecting the device, is carried out by using an adjusting screw, as indicated on Figure 4. The time range is adjustable from 10 seconds to 10 minutes ($\pm 10\%$).

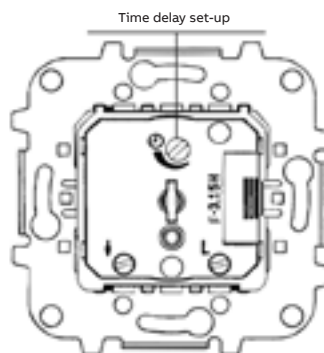

Rotatory thermostat with remote sensor

N2240.3

1.- Technical data

Voltage: 230V~ +/-10% 50-60Hz

Load power: 2.300W.

Load type: floor heating resistor.

Control temperature: +5°C to +45°C (Set point).

OFF state: at OFF position, the thermostat is off, so that it does not address the temperature measured by the floor temperature probe. The relay output contact is open.

Temperature accuracy: 0,5°C.

Hysteresis: 0,5°C.

Floor temperature sensor: NTC, 10KΩ at 25°C, -40°C to 80°C.
Double isolated cable, 4m length.

LED light indication: red and green

Ambient temperature: -20°C to 45°C

2.- Wiring diagram:

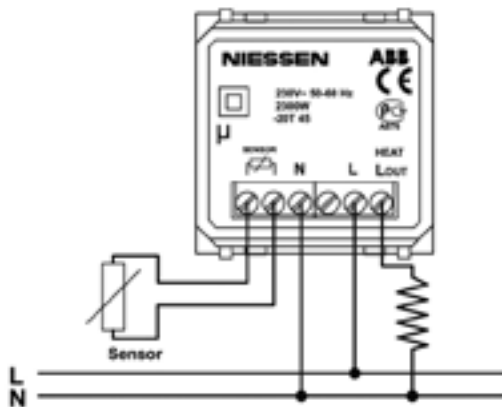

In order to get the better temperature measurement performance possible at the floor thermostat installation, it is recommended:

- Install the thermostat higher than 1m height from the floor.
- Do not install the thermostat near other heat or cold sources.
- Keep the floor temperature sensor away from interference sources or power circuits.
- Check the floor temperature sensor is correctly connected.

Important: Disconnect the mains voltage power when installing.

Work on the 230 V supply system may only be performed by specialist staff!

Disconnect mains power supply prior to installation and/or disassembly!

3.- Mounting

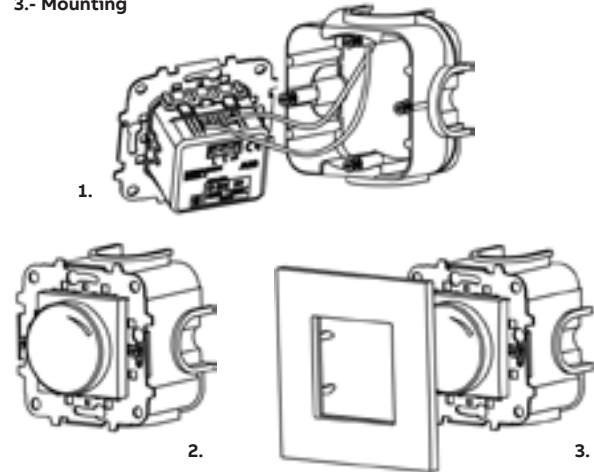

4.- Operation:

The temperature set point can be adjusted by the rotary knob on the front of the thermostat, from +5°C to +45°C.

LED light in the front, indicates the following:

- Red color: Temperature set point is higher than measured temperature at floor sensor. Relay output contact is closed.
- Green color: Temperature set point is lower than measured temperature at floor sensor. Relay output contact is open.
- LED off: Thermostat is OFF state (disconnected).
- Blinking red color: (a) The floor temperature sensor would not be connected or (b) the temperature read by the floor temperature sensor is below.
- 40°C. Relay output contact is closed.

Digital thermostat

8140.5 + N2240.5

1.- Technical data

Voltage: 230 V~ ; 50 - 60 Hz

Power consumption: < 1W

Control temperature: +0°C to +50°C

Temperature accuracy: ±2°C (±1°C with calibration)

Resolution: 0,1°C

Control output: potential-free relay contacts (NA).

Maximum load: 3A cos φ = 0,5.

Hysteresis: 0,5°C

Pulse-width modulation: ±4°C difference with the set-point temperature, variable from 100% to 0% modulation.

2.- Wiring diagram:

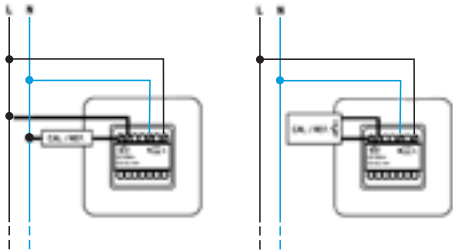

For heating or cooling installations
WITHOUT potential free input

For heating or cooling installations
WITH potential free input

Important: Disconnect the mains voltage power when installing. Work on the 230 V supply system may only be performed by specialist staff! Disconnect mains power supply prior to installation and/or disassembly!

3.- Mounting

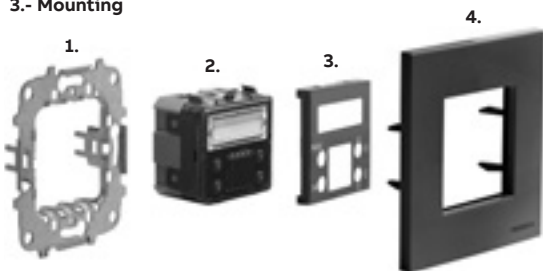

- 1.- Mounting plate
- 2.- Insert - 8140.5
- 3.- Cover plate - N2240.5
- 4.- Frame

4.- Operation:

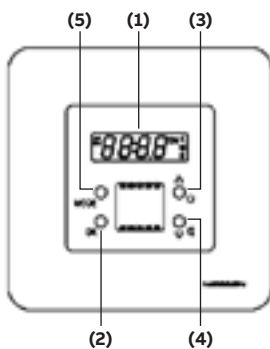

This command allows you to control heating and cooling devices (not simultaneously) from its internal electronic thermostat. Also, thanks to the night mode, allows to maintain a temperature differential (from 0°C to 5°C, also programmable) to save energy with just one keystroke.

Night operating mode C :

It is based on setting a temperature difference (in °C) between day and night, in order to save energy.

Winter mode ❄️ :

To be selected when the equipment under control is a heating equipment.

Summer mode ☀️ :

To be selected when the equipment under control is an air-conditioning equipment.

Temperature control by hysteresis:

Thermostat's default type of control. The use of hysteresis control is particularly suitable for gas boilers.

Pulse-width temperature control:

The use of pulse-width control is particularly recommended for electric heaters, heat pumps or electrothermal actuators.

ATTENTION:

To select between hysteresis and pulse-width, it is necessary that the thermostat is off mode, i.e. the "ON" is not displayed on the screen.

(1) TEMPERATURE DISPLAY

Displays the set-point temperature.

(2) PUSH BUTTON FOR CONFIRMATION OF SELECTED OPTIONS

Confirms the selected values.

(3) ON/OFF AND UP PUSH BUTTON

Turns the control on and off. The display will show "ON" if it is turned on and will turn off when it is off. It serves to increase the Temperature displayed on screen.

(4) NIGHT AND DOWN KEY PUSH BUTTON

Selects between day and night modes. The display will show C in night mode and in day mode it will disappear. It serves to decrease the Temperature displayed on screen.

(5) FUNCTIONS/CONFIGURATION SELECTOR

By pressing "we will adjust the set-point temperature" and, if we press successively, we will choose "winter/summer", "night temperature", "thermometer calibration" and "output relay action mode".

- 1 press on "MODE" to adjust the set-point temperature.

While the set-point temperature and the symbol "°C" flash on the display, set the desired value with "▲ and ▼" and press "OK".

- 2 presses on "MODE" to choose between winter and summer.

While the symbols ❄️ / ☀️ flash on the display, set the desired value with "▲ and ▼" and press "OK".

- 3 presses on "MODE" to choose the night temperature differential.

While the night temperature differential and the symbol C flash on the display, set the desired value with "▲ and ▼" and press "OK".

- 4 presses on "MODE" to calibrate the thermometer.

The temperature indicator flashes and with "▲ y ▼" we select the appropriate ambient temperature. It will be set by pressing "OK".

- 5 presses on "MODE" to choose the "output relay action mode". The "STD" or "INC" will be illuminated on the display when pressing "▲ or ▼". We select the right one and we press "OK".

"STD" indicates the operating mode by hysteresis.

"INC" indicates the operating mode by pulse-width modulation.

In all the cases the setting is validated pressing "OK". Failure to do so, the control returns to the previous settings in 5 seconds without saving the new ones.

With the control turned off, it behaves as a thermometer, showing the current temperature.

ATTENTION:

In the first implementation it is advised to wait **8 hours** before calibration. After an off voltage, the control requires **30 minutes** before showing an accurate temperature.

Rotatory fan control

N2254.1

1.- Technical data

Voltage: 127 V~ ; 60 Hz

Load power: 190 W

Load type: ceiling fan.

Operating temperature: +0°C to +40°C

2.- Wiring diagram:

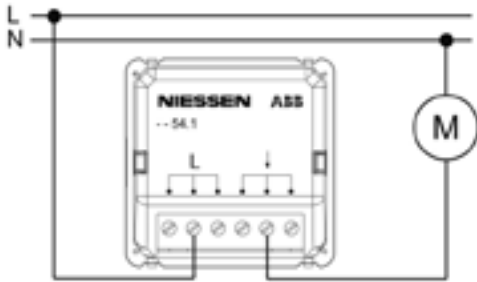

3.- Mounting:

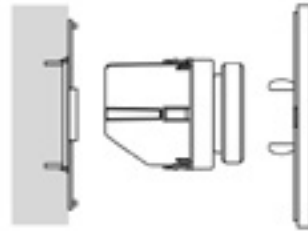

4.- Operation:

Speed / Button position: 0 Disconnected.

I Maximum speed.

II Medium speed.

III Minimum speed.

Important: Disconnect the mains voltage power when installing.
Work on the power supply system may only be performed by specialist staff!
Disconnect mains power supply prior to installation and/or disassembly!

Electronic doorbell

N2224 & N2224.1

1.- Technical data

Voltage:

- N2224: 230 V~ ; 50-60 Hz

- N2224.1: 127V~ 60Hz

4 melodies available.

Acoustic power at 1 meter with cover plate: 72 dB.

2.- Wiring diagram:

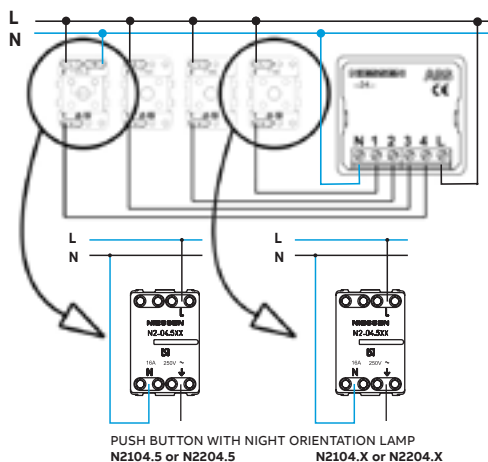

Connection with more than one push-button per melody.

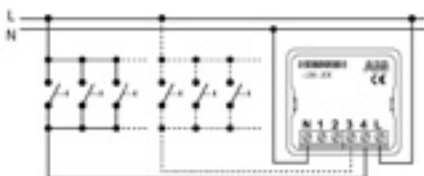

3.- Mounting

To install the device follow these steps:

1. Connect the device based on the corresponding wiring scheme.

2. Mount the device on the wall box.

3. Then, position the plate.

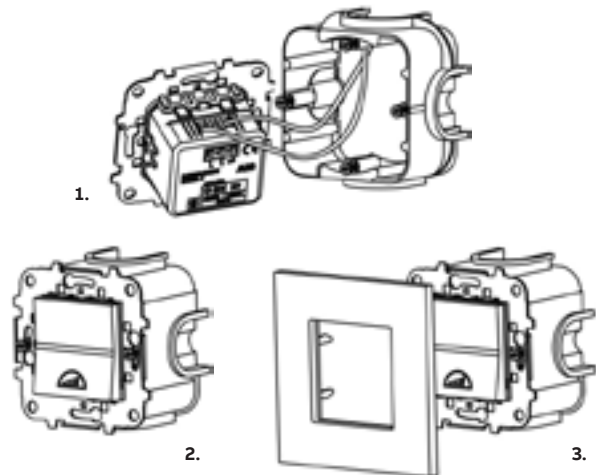

4.- Operation:

The bell can be connected to 4 push buttons maximum, with a different melody for each one of them.

Important: Disconnect the mains voltage power when installing.
Work on the power supply system may only be performed by specialist staff!
Disconnect mains power supply prior to installation and/or disassembly!

Buzzer

N2119 & N2219

1.- Technical data

Rated voltage: 127-230 Vac / 50-60 Hz.

Rated power: 8 VA.

Adjustable tone.

Acoustic power at 1 meter with cover plate: 75 dB.

Note: the buzzer is set for 230Vac operation. For other voltages, the tone must be adjusted by means of the screw regulator on the back.

2.- Wiring diagram:

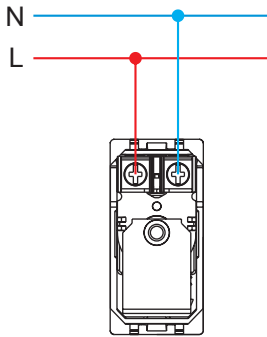

LED signaling light

N2180 BL/RJ/VD, N2180.1 BL, N2280 BL & N2280.2 RJ/VD

1.- Technical data

Rated voltage: 127-230 Vac / 50-60 Hz.

Lamp:

- N2180 BL/RJ/VD / N2180.1 BL / N2280 BL: white LED.
- N2280.2 RJ/VD: red and green LED.

Luminous flux:

- N2180 BL/RJ/VD / N2280 BL / N2280.2 RJ/VD: > 2 lumen at 1 meter.
- N2180.1: < 0,5 lumen at 0,3 meter.

Diffuser:

- N2180 BL / N2180.1 BL / N2280 BL / N2280.2 RJ/VD: white.
- N2180 RJ: red.
- N2180 VD: green.

2.- Wiring diagram:

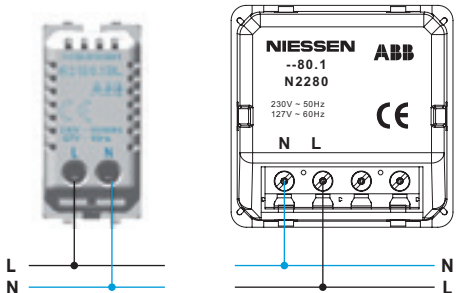

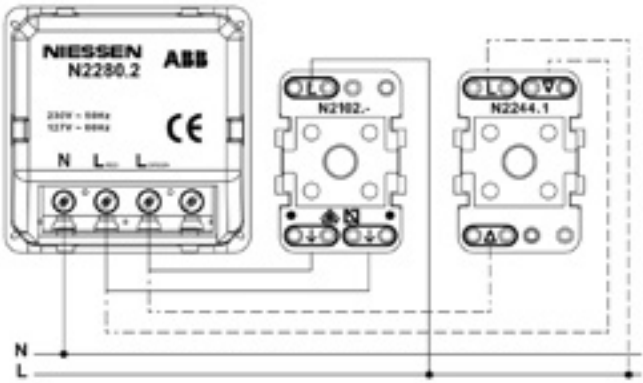

Important: Disconnect the mains voltage power when installing. Work on the power supply system may only be performed by specialist staff! Disconnect mains power supply prior to installation and/or disassembly!

3.- Mounting:

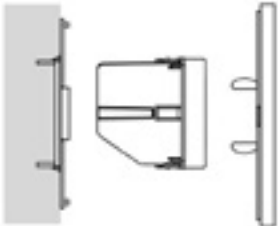

LED beacon light

N2281

1.- Technical data

Rated voltage: 230V~, 50-60Hz (optional 127 Vac version available)

Alert signals: it can be selected by the selector:

- (a) - blue color light or
- (b) - high brightness white light

Autonomy: 2 hours; 1h at maximum illumination and 1h at lower illumination.

Remote control: supports any standard remote control over voltages.

Standard: UNE-EN60598-2-22 Interference suppression according to norms UNE-21806 y EN-55014.

Brightness: more than 2 lumens (lm) at 1 meter distance.
Battery Nickes-Metal Hydride (Ni-MH), with less environmental impact.

Note: Ni-MH batteries have an estimated life of 4 years. Beacon Pilots correct operation should be verified periodically. In the absence of voltage and previously to have been connected to voltage for more than 24 hours, the mechanism should provide a minimum of one hour beacon lighting, if not, replace the mechanism.

2.- Wiring diagram:

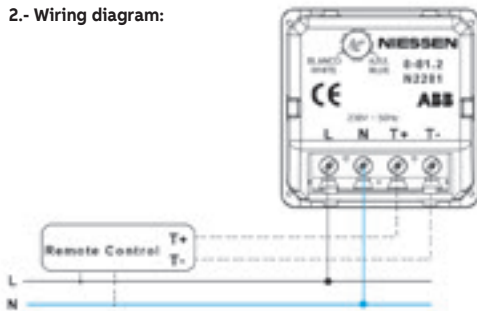

3.- Mounting:

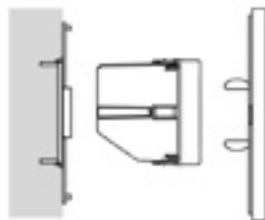

4.- Operation:

The stairs beacon pilot is an autonomous signaling device, equipped with an electric energy storage battery, which ensures the correct building pathways signaling lighting in the event of a power outage or when it drops below 70% of its nominal value (230V~).

Once connected to mains voltage the device can remain in the following operation situations:

- (1) Alert (signaling)
- (2) Operation (beacon)
- (3) Standby (remote control)

Alert (signaling)

The device remains on alert (signaling), provided that the value of the power supply exceeds 70% of the power supply nominal voltage (230V~ 50-60Hz).

Emergency operation

It comes into an emergency operating condition when the power supply voltage is less than 70% of rated voltage (230V~ +/-10%). The device is illuminated with high brightness white color.

Note: The time necessary to recharge the device batteries is 24 hours.

Standby (remote control)

Situation in which the device remains off, even when the power supply voltage is interrupted. This action is achieved by using a remote control connected to the equipment, as shown in figure "Device connection". This way you can select certain number of appliances, from the total installed drivers, to remain off in a power failure, thereby reserving the batteries charge in case of a possible need for further use if the power outage is prolonged.

This is achieved by acting on the remote control that generates a continuous control signal or low voltage pulses, which acts on the pilot/s by placing it/them at standby or running again (beacon), as desired.

When achieving this type of installation, make sure of the correct connection of the different drivers.

Select the color of the device signaling light in alert situation (signaling).

No need to disconnect the supply voltage of the device to select the alert light through the potentiometer. Although the remote control inputs were connected, these should not be active at the time of selecting the alert light through the potentiometer.

Important: Disconnect the mains voltage power when installing.

Work on the power supply system may only be performed by specialist staff!
Disconnect mains power supply prior to installation and/or disassembly!

Make Up Room / Do Not Disturb system

N2180.4, N2180.5 & N2244.5

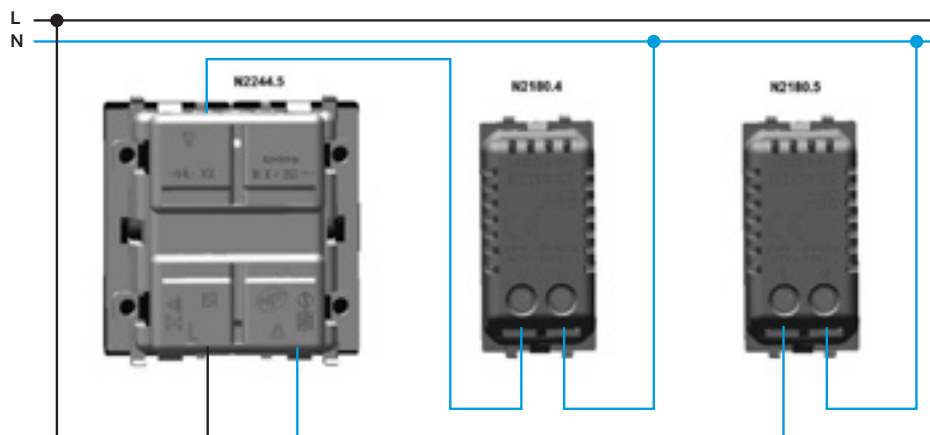

Zenit elastic claws

Mounting the claws on the metal mounting plate

The elastic claws are inserted into the metal support of the mechanisms. For this, there is a guide where at the end of the path the claws are clipped and are perfectly secured, making a block with the mounting plate.



Once the claws are assembled, place the screwdriver in the mounting plate to level it and mount it correctly in the box.



The assembly is pressed into the housing.

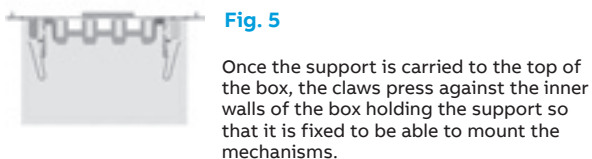
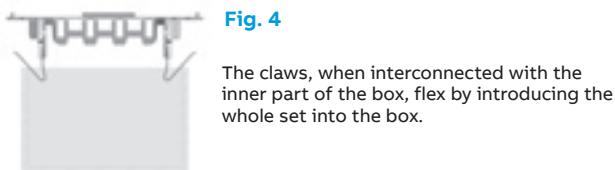

Once the support is carried to the top of the box, the claws press against the inner walls of the box holding the support so that it is fixed to be able to mount the mechanisms.
The system is effectively fixed without the need for any additional elements. It supports the stresses to which the elements inserted in the ring can be subjected, in their habitual use. (insertion of plugs, rocker pressing, etc.)

Insertion of a 1-module mechanism in a mountin plate with elastic claws.

- 1- Insert the additional parts (elastic claw insert ref. N2071.8).
- 2- Insert the 1-module mechanism into the metal bracket.

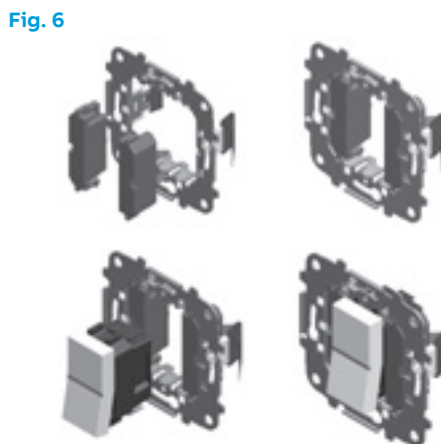

Removing the mounting plate and claws from the box

In order to be able to disassemble the entire set, simply insert a tool (screwdriver) and press on each of the claws until they are released from the mechanism support, they fall into the inside of the box and it is now possible to remove all the system. To reassemble it you have to restart the whole process explained before.



Zenit sound system

A soundtrack in each space

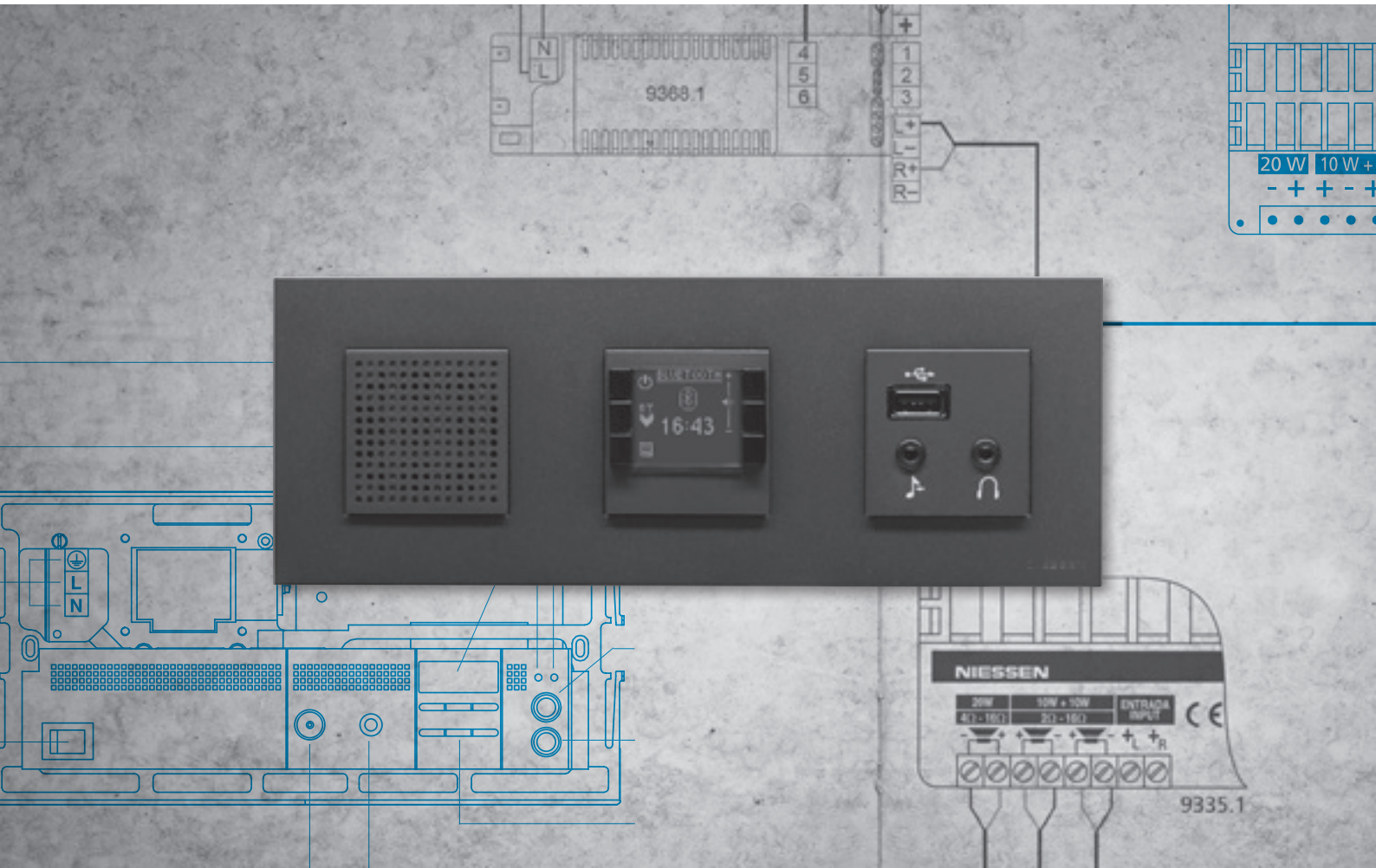

FM stereo receiver with alarm module

9368

1.- Technical data

Rated voltage:
 - 9368: 230 V~; ±15%; 50-60 Hz
 - 9368.7: 127 V~; ±15%; 50-60 Hz

Max. consumption: 100 mA

Stand-by consumption ref. 9368 and 9368.7 (*): 0,2 W.

Stand-by consumption ref. (9368 or 9368.7) + 9368.3 (*): 0,5 W.
 (*) With the display illumination at minimum.

Maximum output power: 2+2 W; <1% distorsion (16 W)

Speaker impedance: 16 W (2+2 W audio)

3.- Mounting:

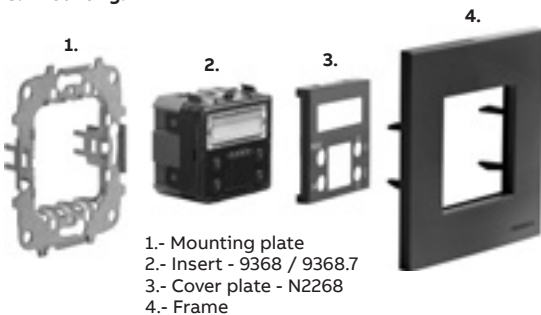

1.- Mounting plate
 2.- Insert - 9368 / 9368.7
 3.- Cover plate - N2268
 4.- Frame

2.- Wiring diagram:

(*) FM RECEPTION
 The FM indoor antenna that incorporates the module 9368 or 9368.7, uses the electrical network to improve reception. If the reception is not quite right, you can connect an external FM antenna (thin wire or coaxial wire) in the connectors enabled for it.

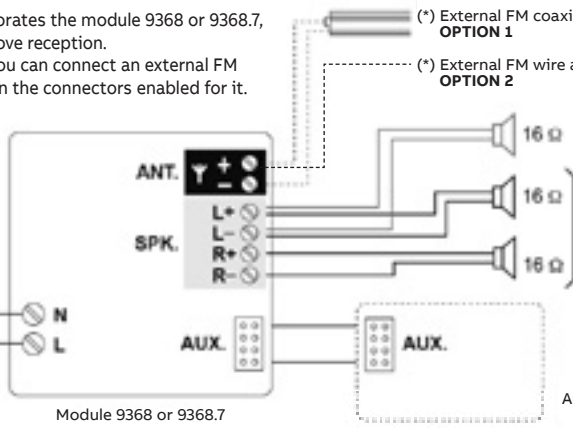

ANT. (+, -, GND) → (*) External FM coaxial antenna. **OPTION 1**
 (*) External FM wire antenna (75 cm. max.). **OPTION 2**

SPK. L+, L-, R+, R- → 16 Ω Mono configuration. Local speaker.
 Stereo configuration. Separate speakers.

AUX. → 9368.3 Audio input/output module + USB and Bluetooth® (OPTIONAL)

Power supply: 9368: 230 V~; ±15%; 50-60 Hz; 9368.7: 127 V~; ±15%; 50-60 Hz

Auxiliary module

9368.3

1.- Technical data

Power supply through AUX.: 9 V

Maximum consumption: 175 ~ 200 mA

Consumption stand-by: 0.4 W

Headphones impedance: 16 ~ 600 Ω (25 + 25 mW audio phones)

Bluetooth®: Bluetooth® v2.1 2.4GHz IEEE 802.15.1
 Maximum reach from the module 9368.3 to user's Bluetooth® device: 10 m.

3.- Mounting:

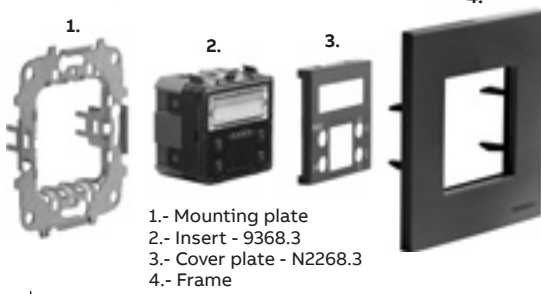

1.- Mounting plate
 2.- Insert - 9368.3
 3.- Cover plate - N2268.3
 4.- Frame

2.- Wiring diagram:

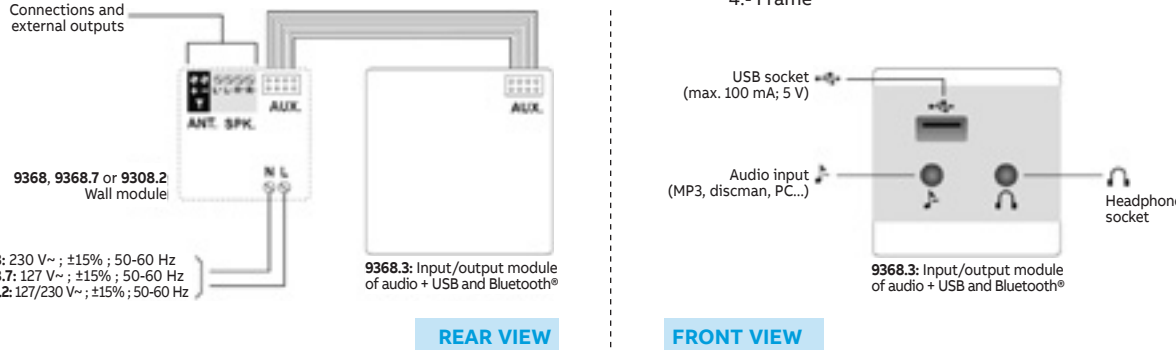

REAR VIEW: Connections and external outputs. 9368, 9368.7 or 9368.2 Wall module. 9368.3: Input/output module of audio + USB and Bluetooth®

FRONT VIEW: USB socket (max. 100 mA; 5 V), Audio input (MP3, discman, PC...), Headphone socket. 9368.3: Input/output module of audio + USB and Bluetooth®

Radio & Bluetooth multiroom module + Remote control module

9368.1 & 9368.2

1.- Technical Data

Power supply:

230 V~ / 127 V~; $\pm 15\%$; 50-60 Hz

Bluetooth®:

Bluetooth® v2.1 2.4GHz IEEE 802.15.1

Maximum reach from the ceiling module
9368.1 to user's Bluetooth® device: 10 m.

Maximum power consumption:

200 mA

Consumption stand-by:

0.3 W

Communication data:

ZigBee 2.4GHz IEEE 802.15.4

Antenna impedance:

75 Ω

Maximum power headphone output

6+6 W; <1% distortion (4 Ω)

Minimum impedance of headphones:

4 Ω (6+6 W audio)

2.- Wiring diagram:

BUS MULTIROOM is only necessary if there is more than one room in the house and/or you want to connect the rooms in the house.

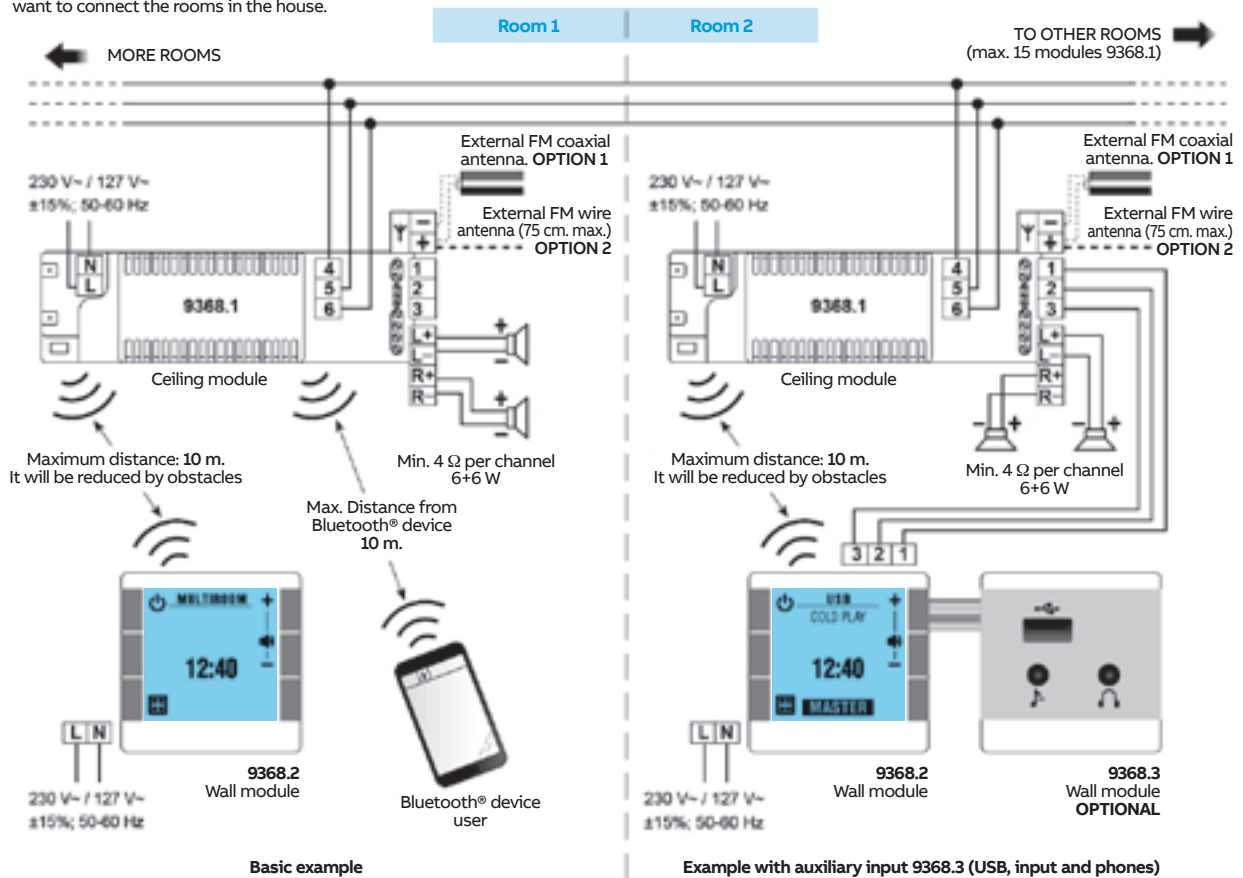

NOTE: Because these devices are radio frequency and to avoid interference, you should not install modules of the same reference or any other RF equipment that could interfere less than 1 m. away. It should be noted that any obstacle between the devices, can significantly reduce the distance range between them.

3.- Mounting:

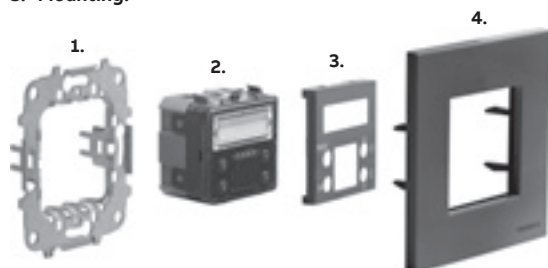

- 1.- Mounting plate
- 2.- Insert - 9368 / 9368.7
- 3.- Cover plate - N2268
- 4.- Frame

Sound amplifier - Connection to multiroom module

9335.1 - 9368.1

Wiring diagram of 9368.1 module to 9335.1 sound amplifier

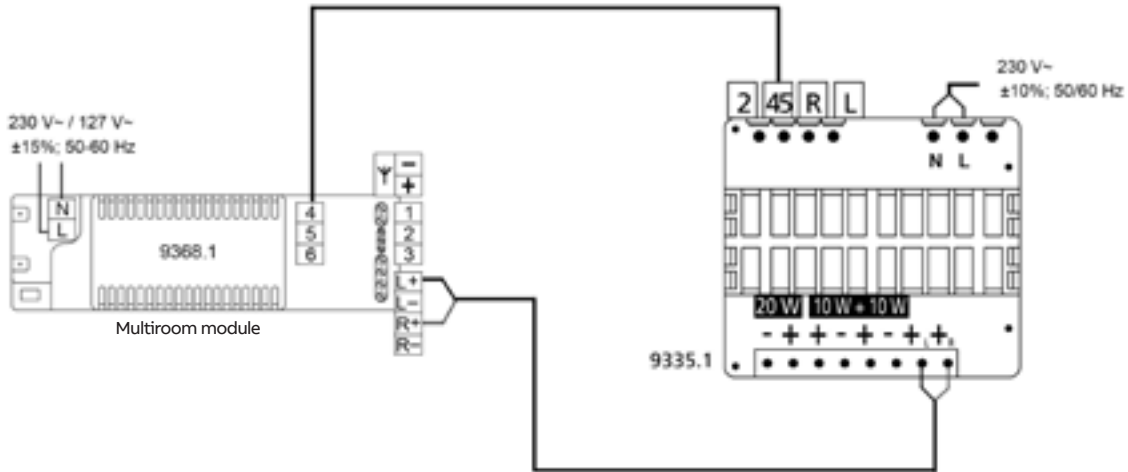

Wiring diagram for 9329.1 loudspeakers to 9335.1 sound amplifier

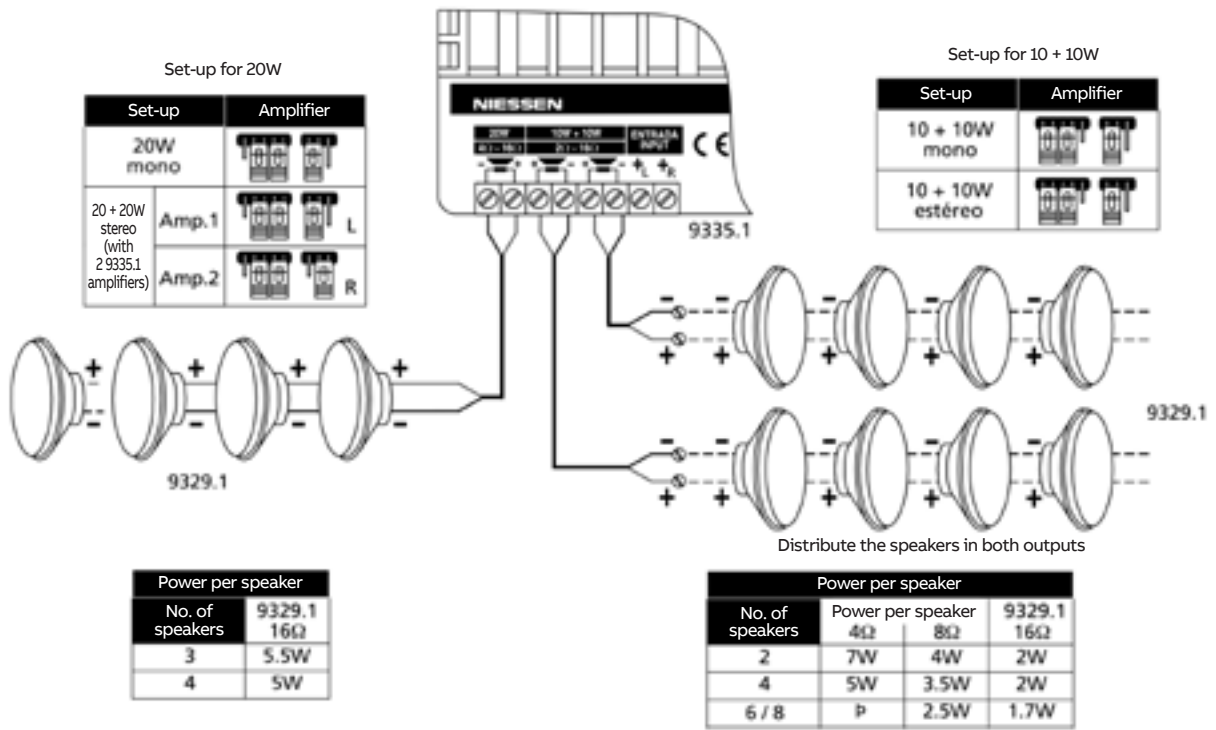

Zenit Centralizations and Workstations

Cutting-edge connectivity

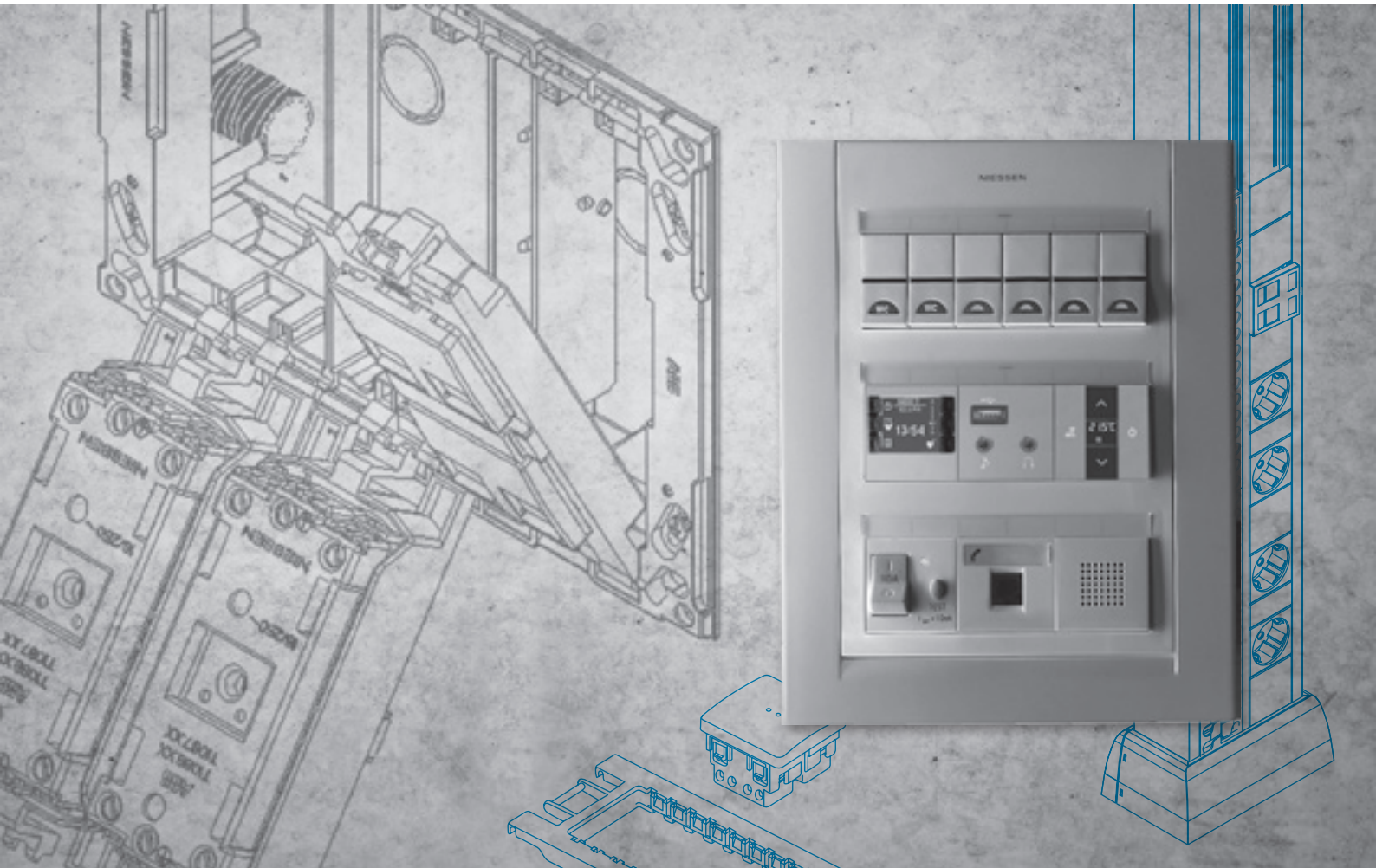

Surface and flush-mounted Centralizations

1. For the mounting of the surface and flush mounting boxes, please check the diagrams for the Workstations in the next page.

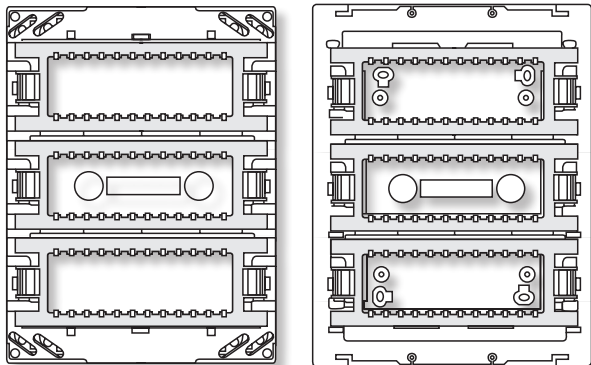

2. Both in the surface solution and in the flush solution, there are metal mounting plates where the mechanisms are inserted.

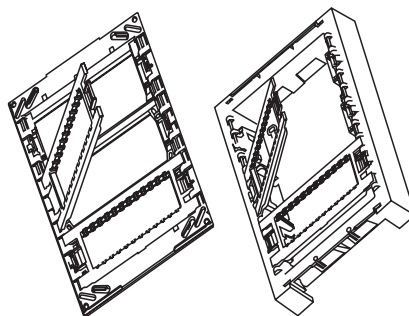

3. The mechanisms are inserted in the mounting plate by pressure.

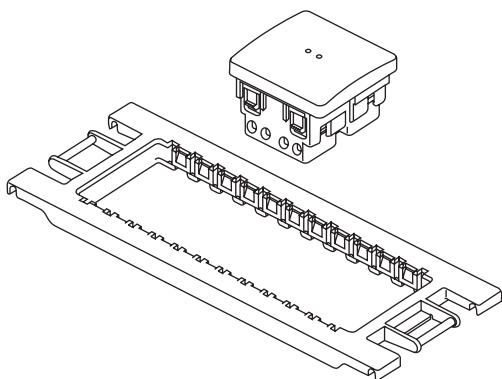

4. Once inserted, proceed with the wiring.

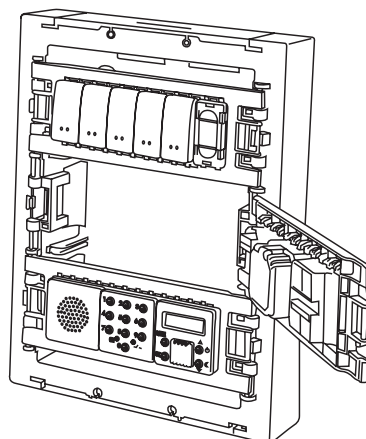

5. The mounting plate is closed by clipping.

6. Once all the devices are wired and the mounting plates correctly placed, the frame is mounted by clipping it to the box.

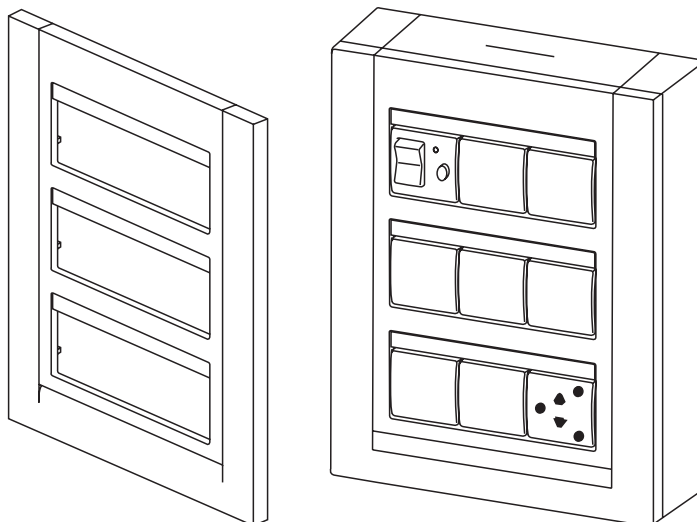

Installation of the surface mounting boxes for Workstations

T1193, T1194, T1195

Installation of the box

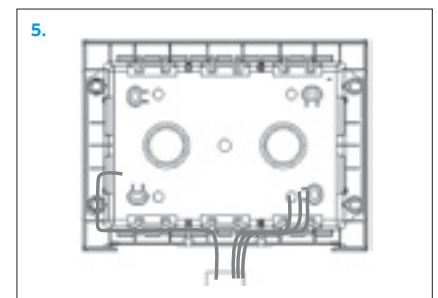
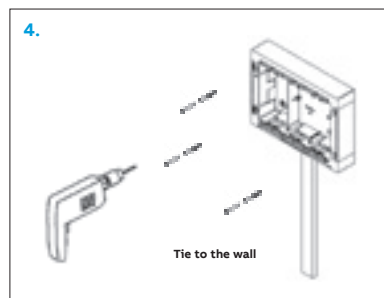
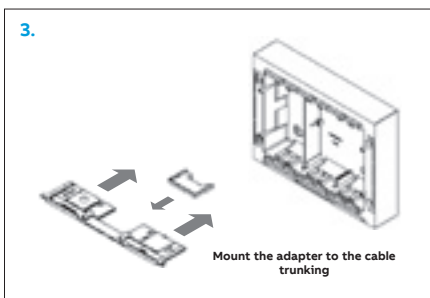
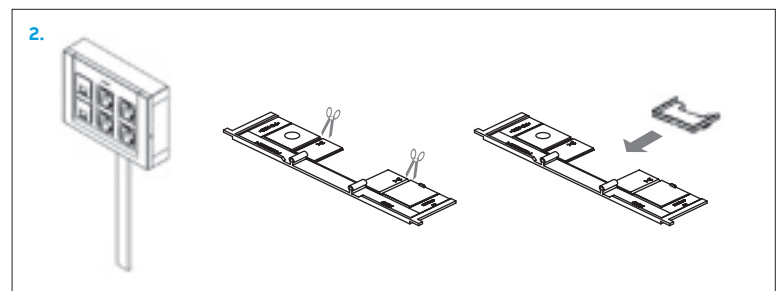
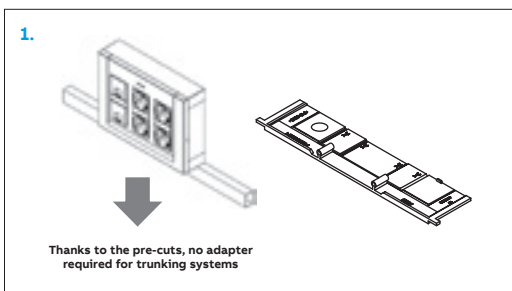
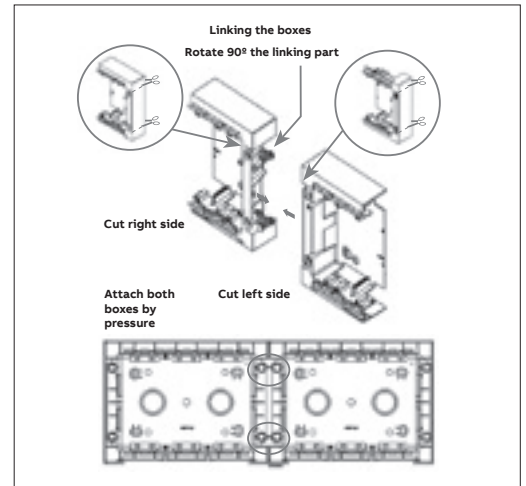
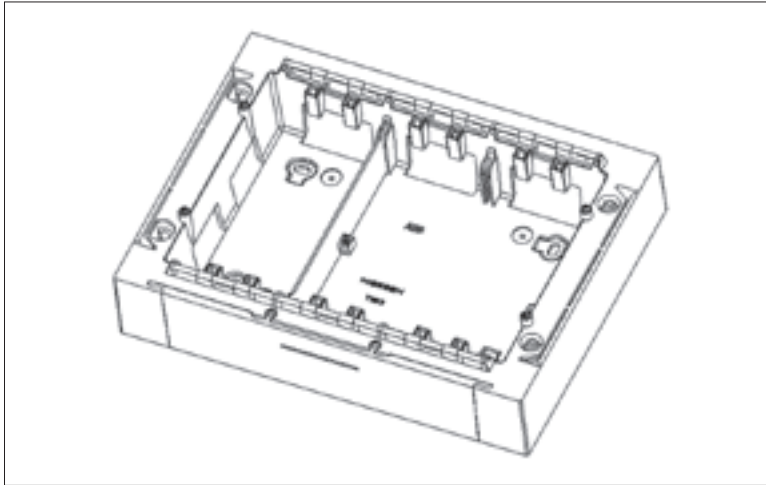

Installation of mechanisms

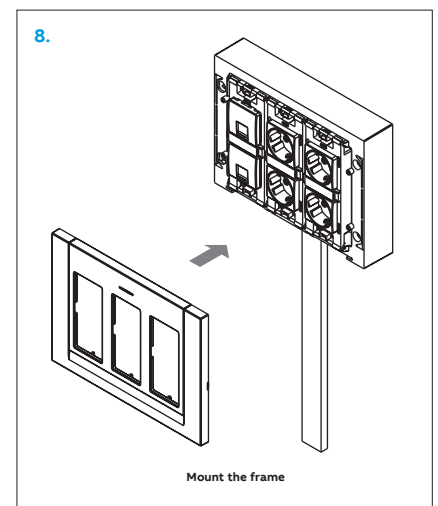
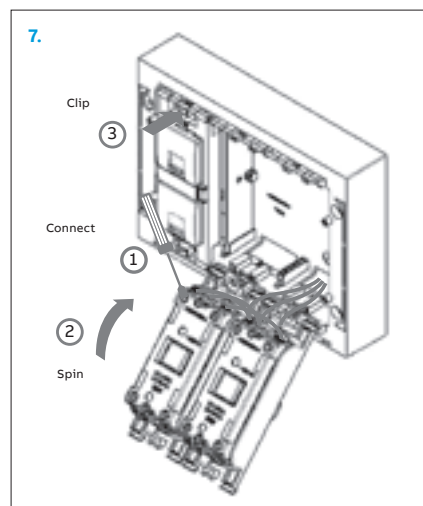
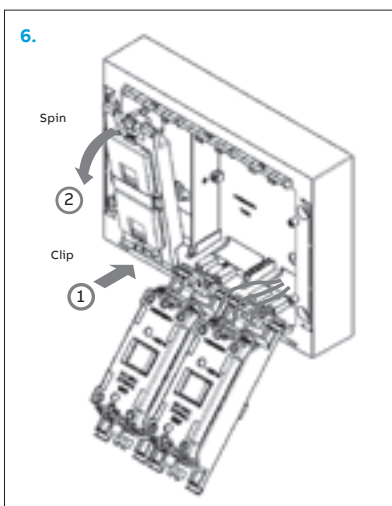

Installation of the flush mounting boxes for Workstations

T1093, T1094

Installation in cement and brick walls

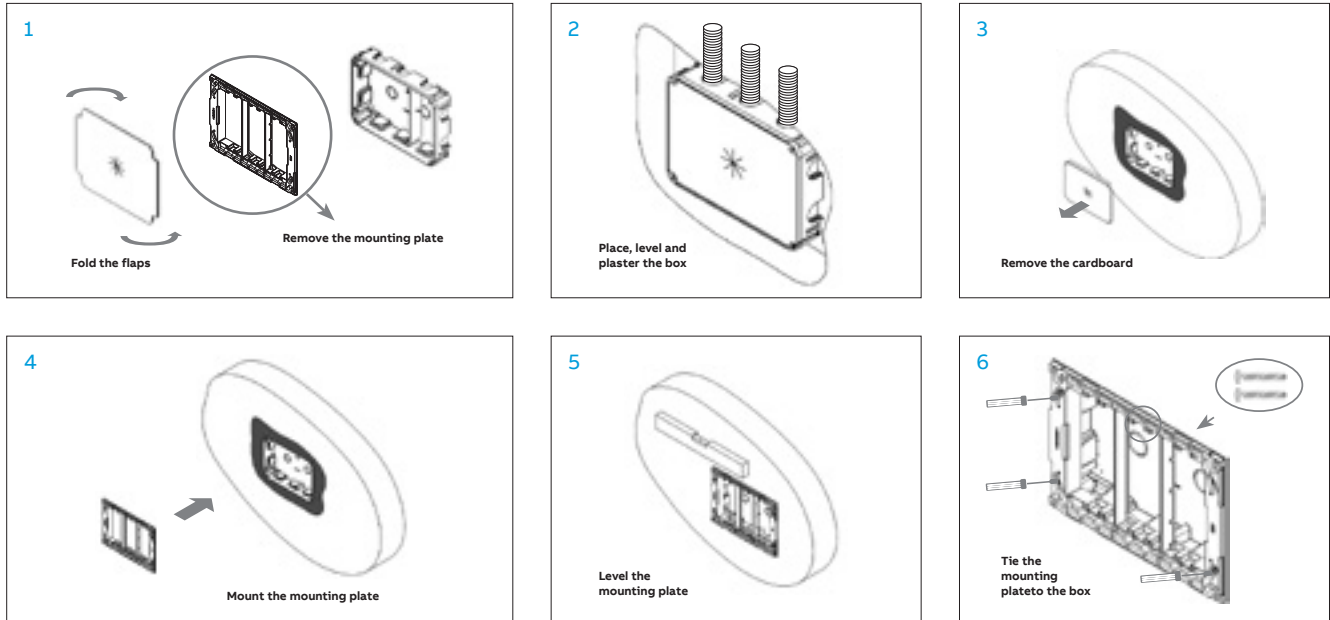

Installation in drywall / hollow partition

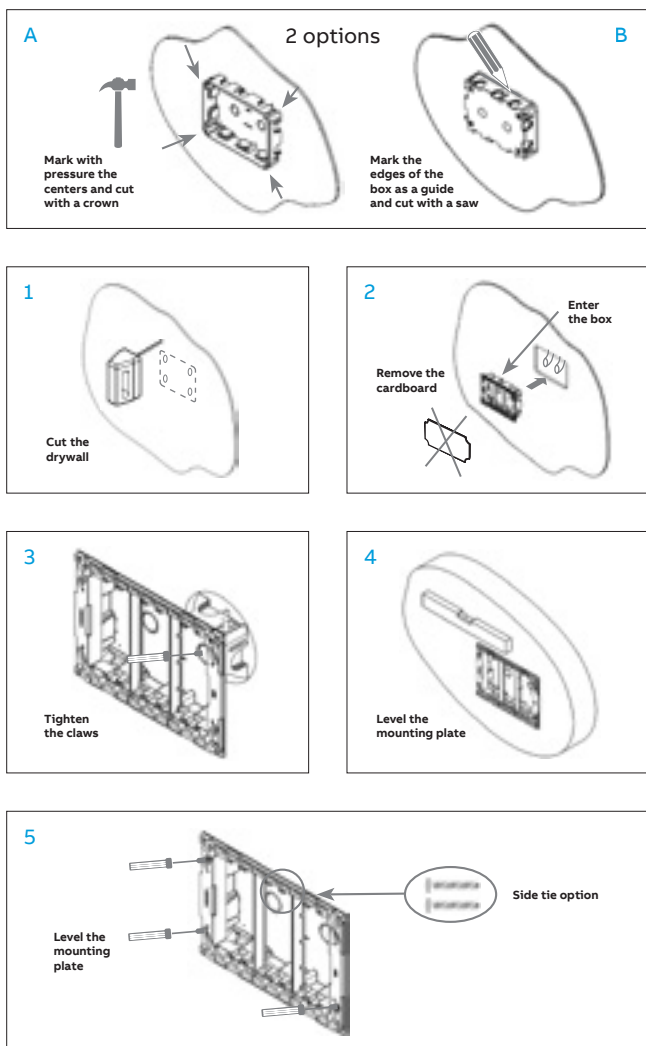

Linking the boxes in cement / brick walls

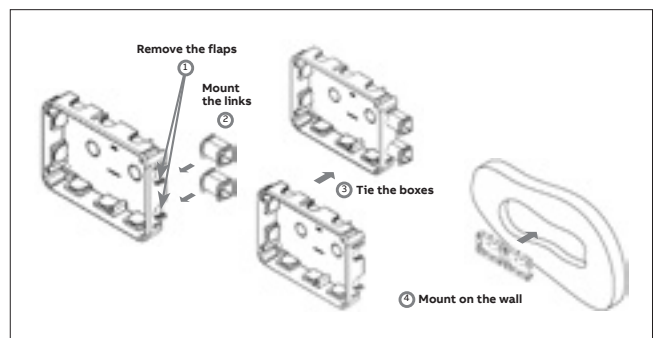

Linking the boxes in drywall / hollow partition

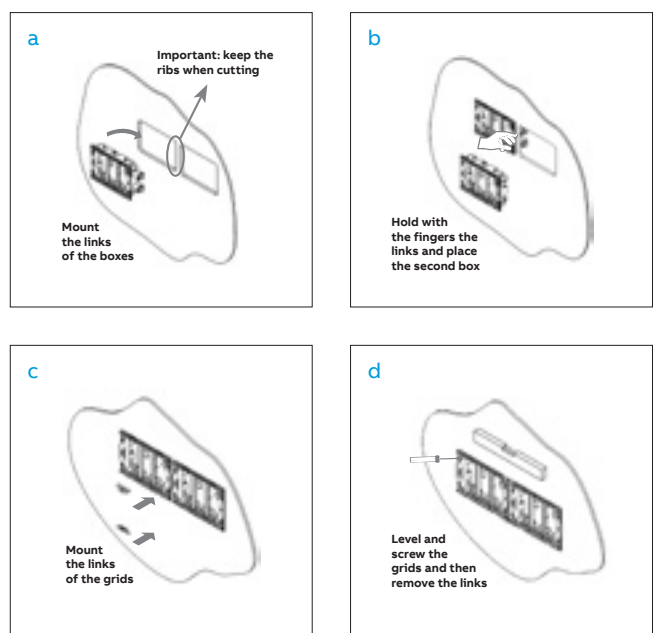

Installation of inserts in flush mounting Workstations

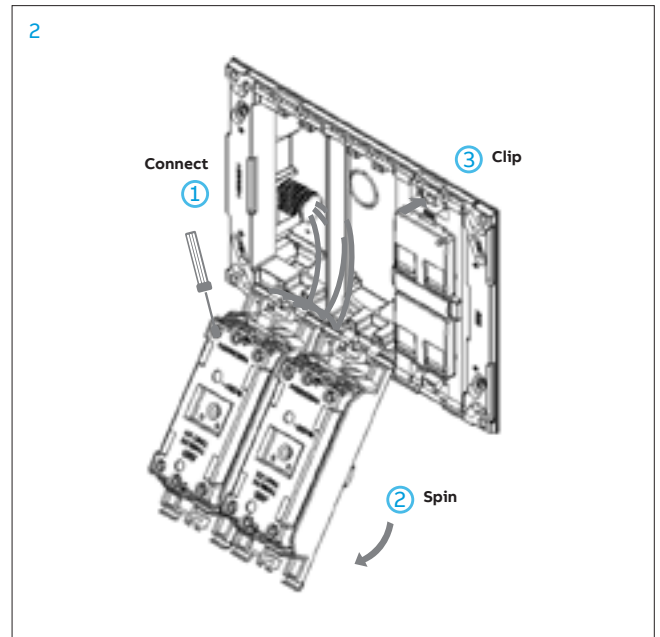
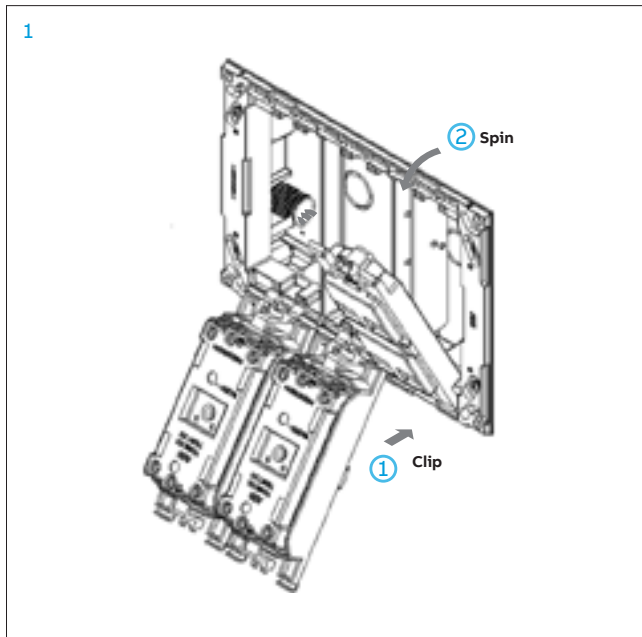

Installation of the foldable lid in the Workstations

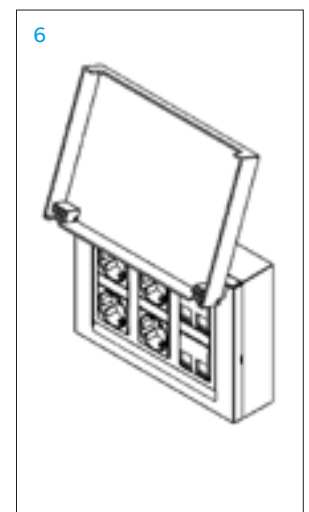
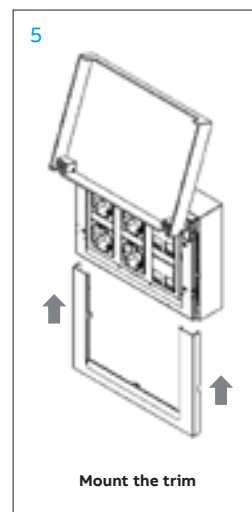
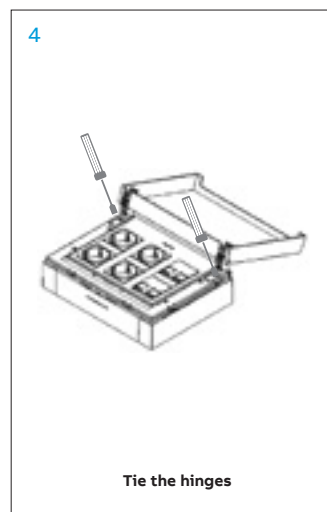
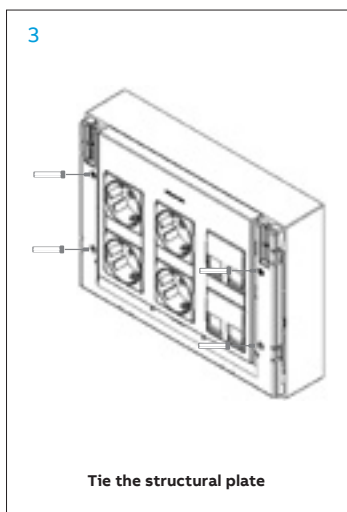
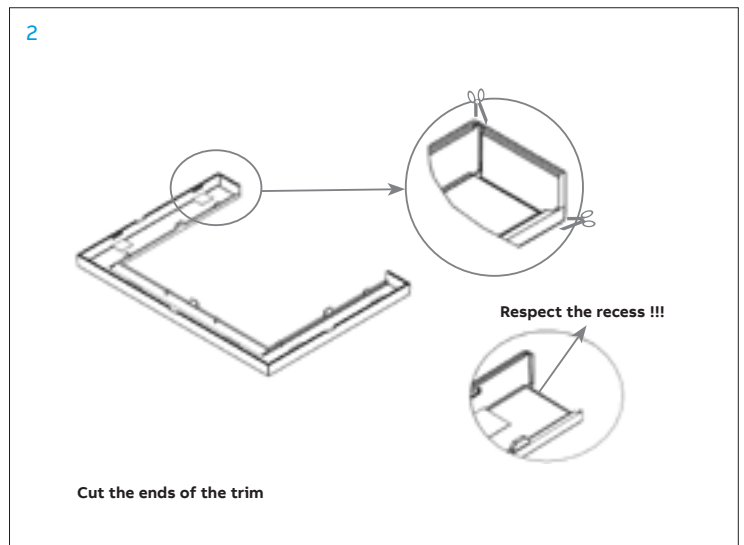
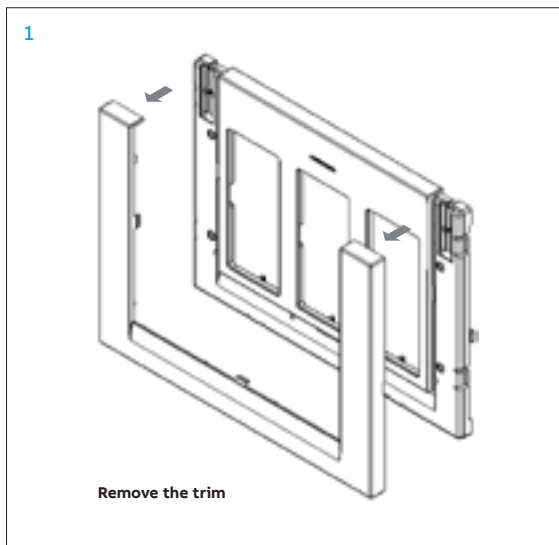

Installation of the floor box

Installation of the frame T1373 and inserts T10XX

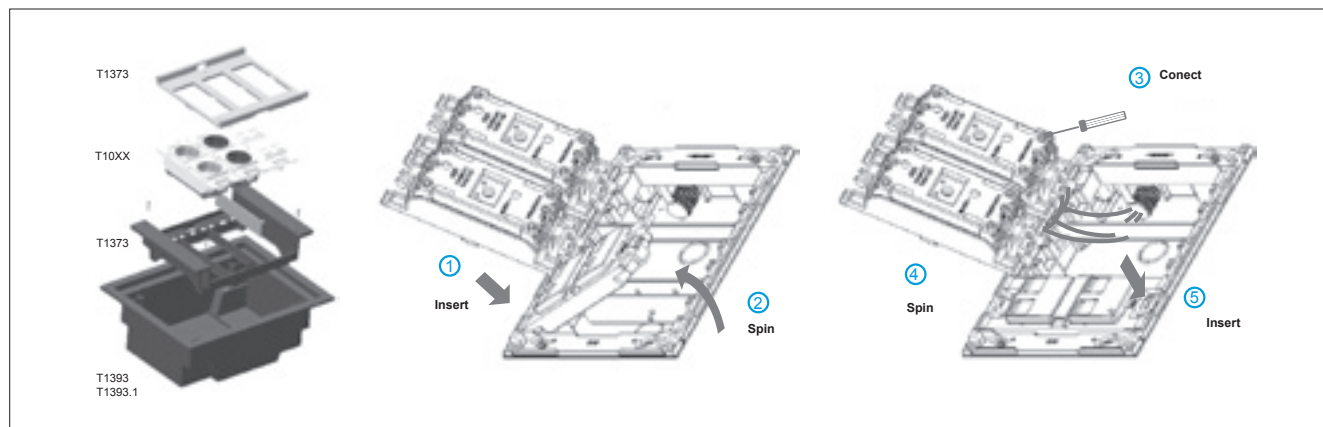

Installation in flush floor

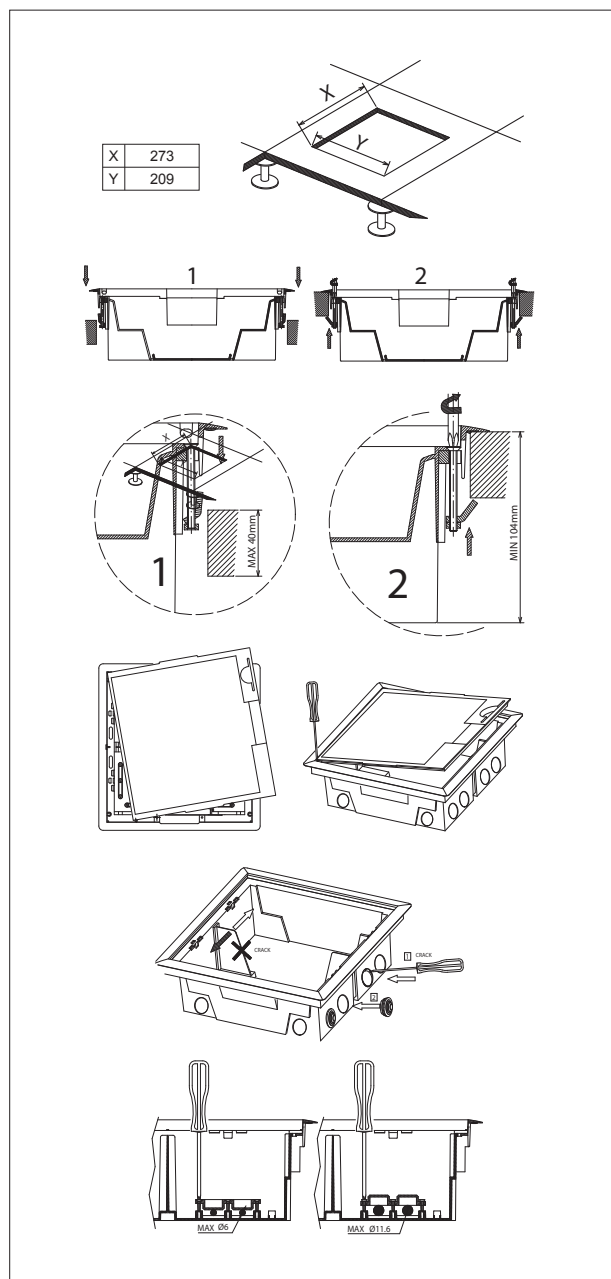

Installation of frame bracket T1393.4

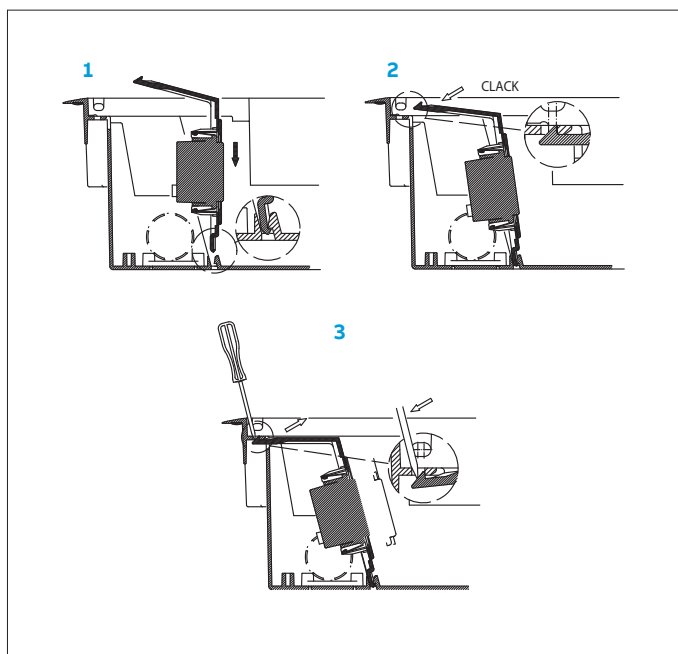

Installation in concrete floor T1393.9

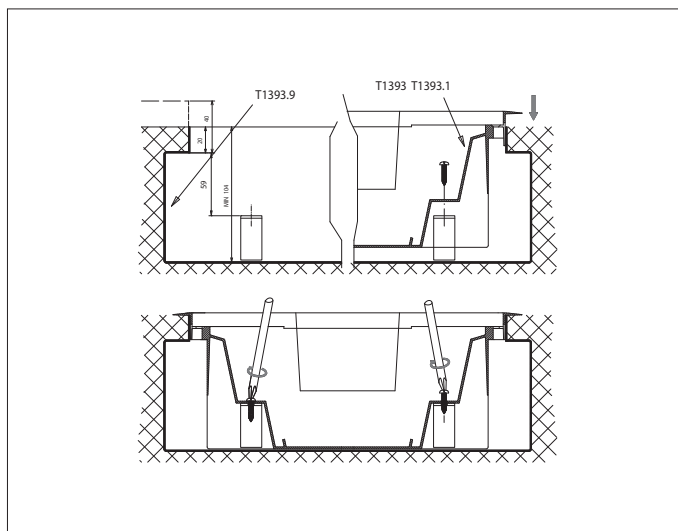

Dimensions

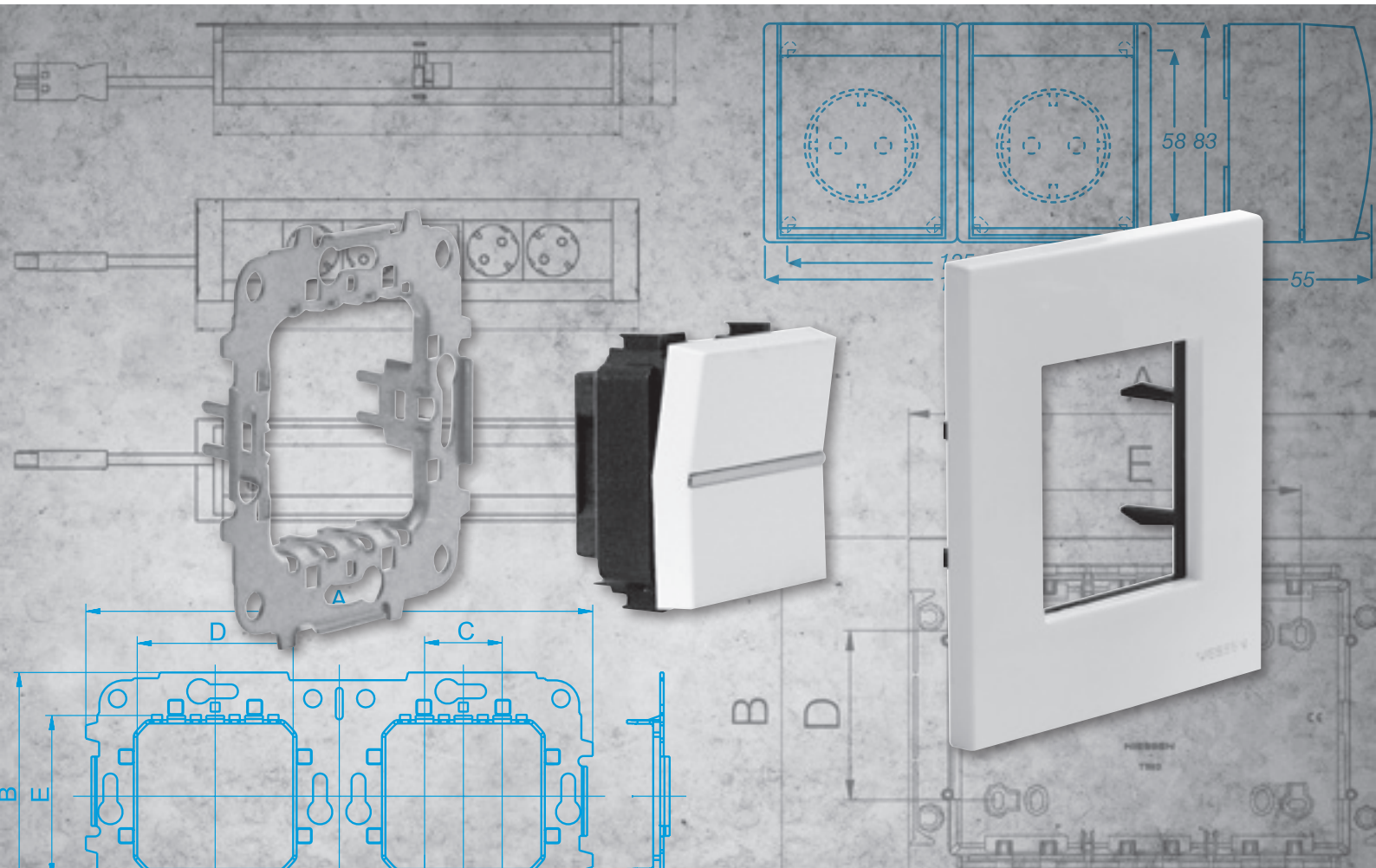

Frames

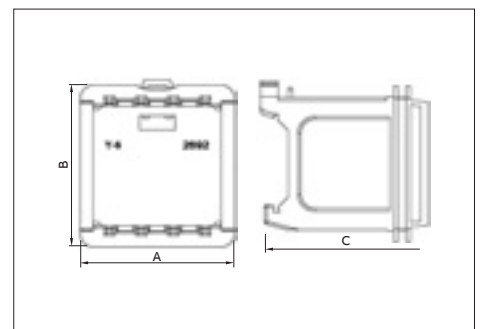
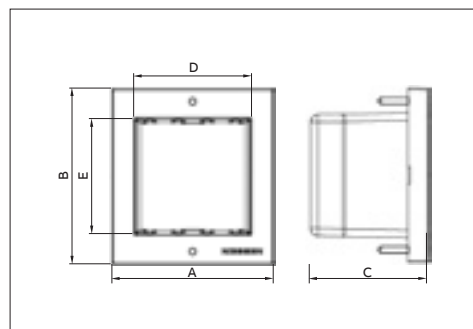
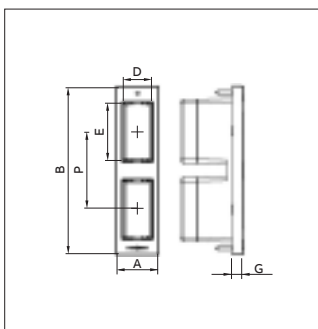
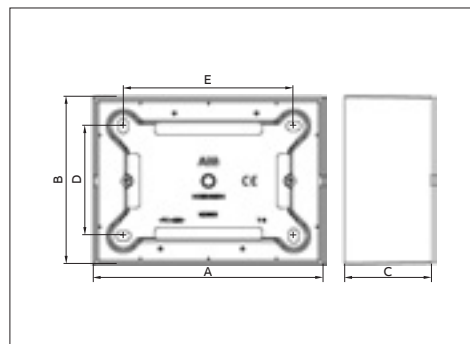
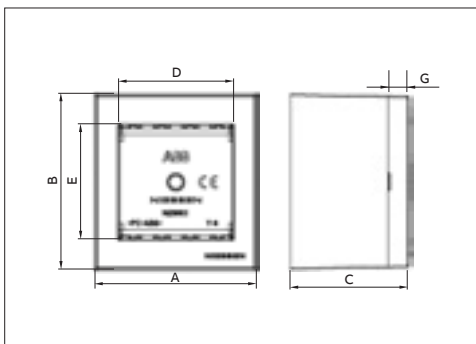
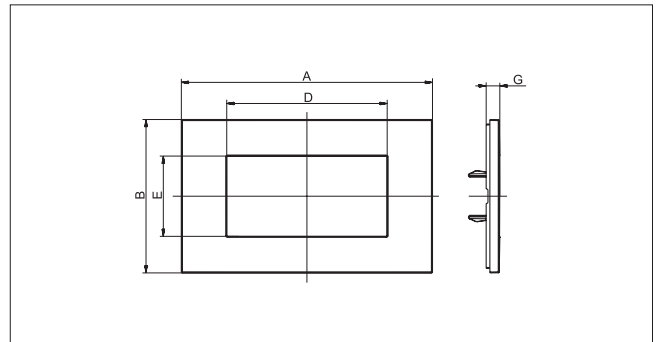
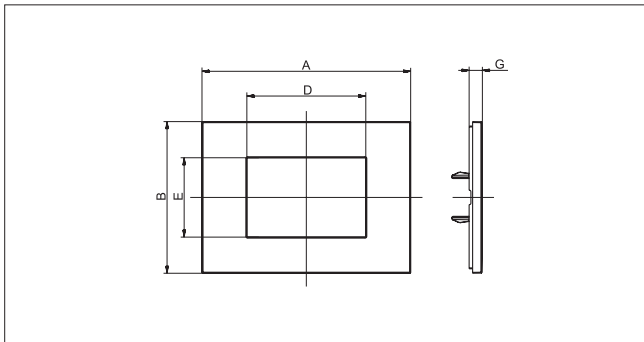
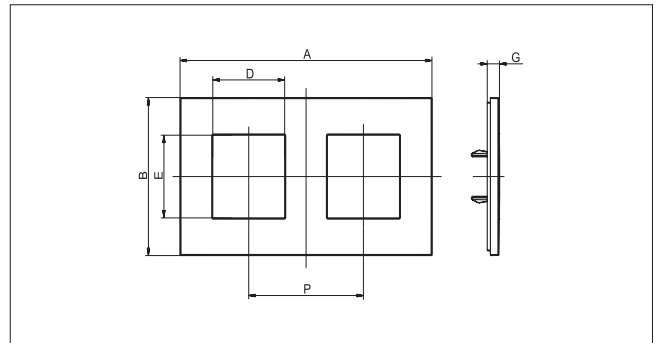
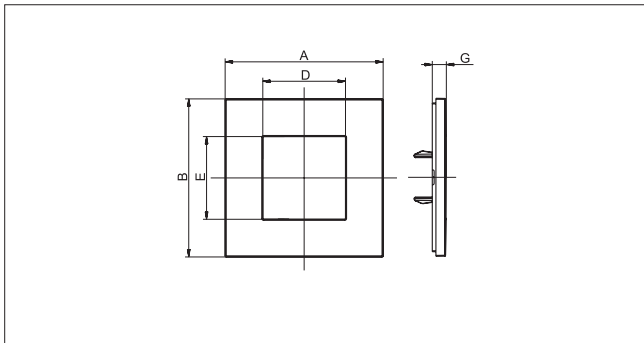
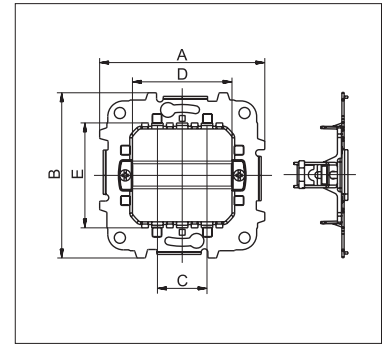
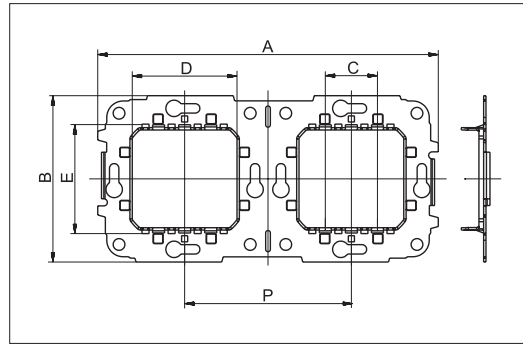
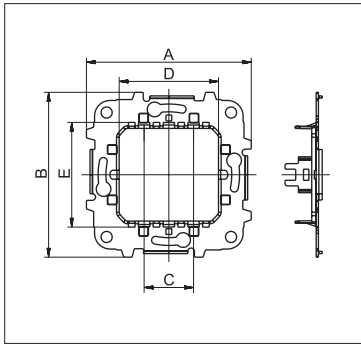

Frames

Type	Article No.	A	B	C	D	E	G	P
Frames for square boxes (60mm screw distance)	N2171 1-gang (1M)	85	85	-	22,4	44,6	7,5	-
	N2171.1 1-gang (1M)	85	85	-	22,4	44,6	7,5	-
	N2271 1-gang (2M)	85	85	-	44,6	44,6	7,5	-
	* N2271 1-gang (2M)	90	90	-	44,6	44,6	8	-
	N2271.1 1-gang (2M)	85	85	-	44,6	44,6	7,5	-
	N2272 2-gang (2M)	156	85	-	44,6	44,6	7,5	71
	* N2272 2-gang (2M)	161	90	-	44,6	44,6	8	71
	N2272.1 2-gang (2M)	156	85	-	44,6	44,6	7,5	71
	N2273 3-gang (2M)	227	85	-	44,6	44,6	7,5	71
	* N2273 3-gang (3M)	232	90	-	44,6	44,6	8	71
	N2273.1 3-gang (2M)	227	85	-	44,6	44,6	7,5	71
	N2274 4-gang (2M)	298	85	-	44,6	44,6	7,5	71
	* N2274 4-gang (4M)	303	90	-	44,6	44,6	8	71
	N2274.1 4-gang (2M)	298	85	-	44,6	44,6	7,5	71
N2275 5-gang (2M)	369	85	-	44,6	44,6	7,5	71	
Frames for 3 module boxes (83,5mm screw distance)	N2370.1 Blank	122	90	-	-	-	7,5	-
	N2371.1 1-gang (1M)	122	90	-	22,4	44,6	7,5	-
	N2371.1V 1-gang V (1M)	122	90	-	44,6	22,4	7,5	-
	N2372.1 1-gang (2M)	122	90	-	44,6	44,6	7,5	-
	* N2372.1 1-gang (2M)	122	90	-	44,6	44,6	8	-
	N2372.2 2-gang (1+1M)	122	90	-	22,4	44,6	7,5	-
	N2373.1 1-gang (3M)	122	90	-	66,8	44,6	7,5	-
	* N2373.1 1-gang (3M)	122	90	-	66,8	44,6	8	-
Frames for 4 module boxes (107mm screw distance)	N2374.1 1-gang (4M)	139,2	85	-	89	44,6	7,5	-
	* N2374.1 1-gang (4M)	142	90	-	89	44,6	8	-
Frames for 7 modules boxes (100mm screw distance)	N2777.1 1-gang (7M)	196	85	-	155,6	44,6	7,5	-
Mounting grids	N2271.9 1-gang (2M)	74	74	22,2	44,6	47	-	-
	N2272.9 2-gang (2M)	145	70,8	22,2	44,6	44,6	-	71
	N2271.9G 1-gang (2M)	74	74	22,2	44,6	47	-	-
	N2273.9 3-gang (2M)	216	70,8	22,2	44,6	44,6	-	71
	N2371.9V 1-gang (2M)	102	74	22,2	44,6	44,6	-	-
	N2373.9 1-gang (3M)	102	74	22,2	66,8	44,6	-	-
	N2374.9 1-gang (4M)	124	74	22,2	92	44,6	-	-
	N2673.9 1-gang (3+3M)	102	122	22,2	66,8	44,6	-	-
	N2777.9 1-gang (7M)	194	79	22,2	158	44,6	-	-
Surface mounting boxes	N2991.1 BL	62	68	47	44,6	44,6	8,5	-
	8591 BL	86	86	44,2	58	58	-	-
	8592 BL	157	86	44,2	58	129	-	-
	8593 BL	228	86	44,2	58	200	-	-
	N2993 BL	117	85	44,2	56	87	-	-
	N2994 BL	139,2	85	44,2	56	110,2	-	-
Frames for profiles	N2671	32	68	46,5	22,4	44,6	8,5	-
	N2671.2	32	126	46,5	22,4	44,6	8,5	-
	N2672	62	68	46,5	44,6	44,6	8,5	-
DIN-rail mounting plate	2692 BL	53,5	56	58,5	-	-	-	-

* Noble materials

IP55 flush-mounting boxes

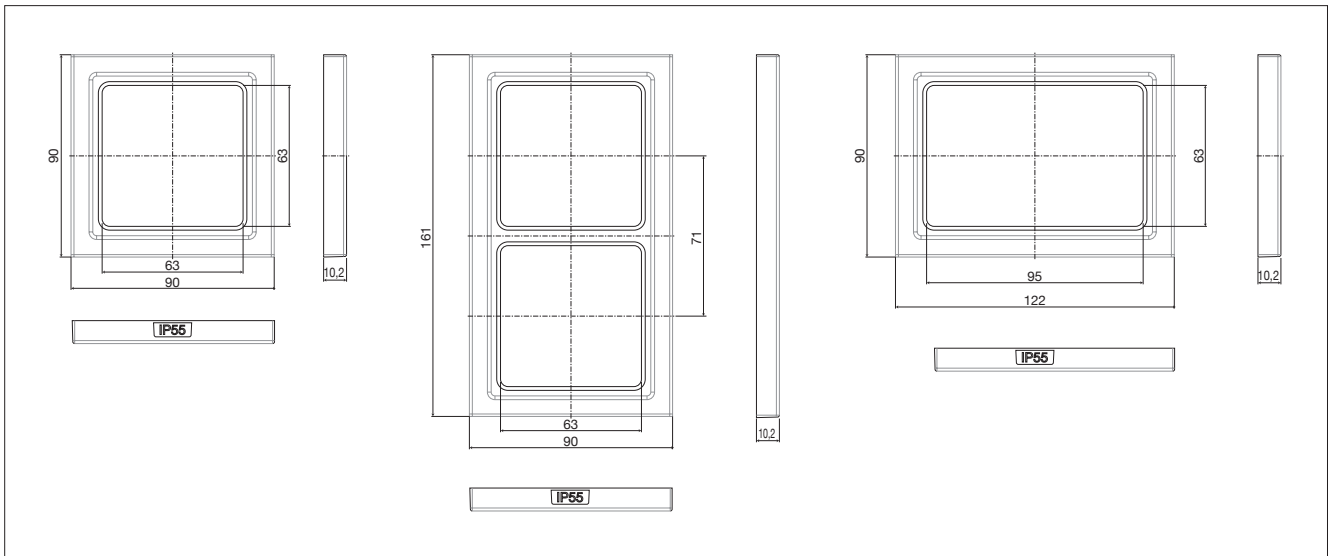

IP55 surface mounting boxes

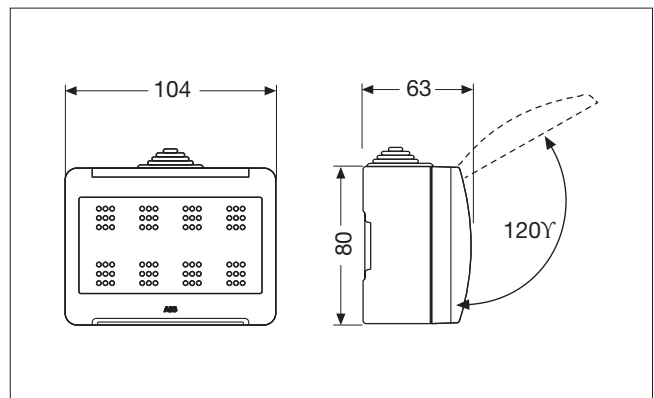
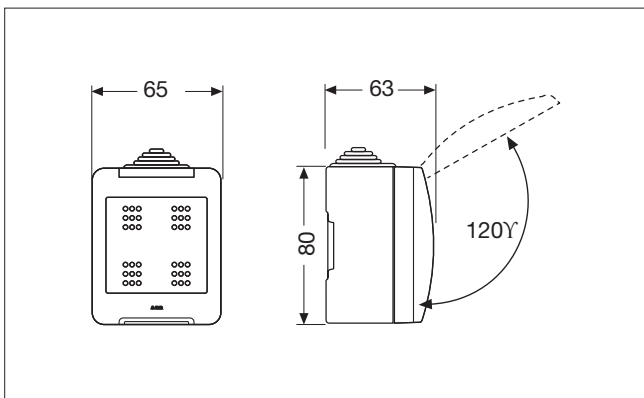

IP40 surface mounting boxes

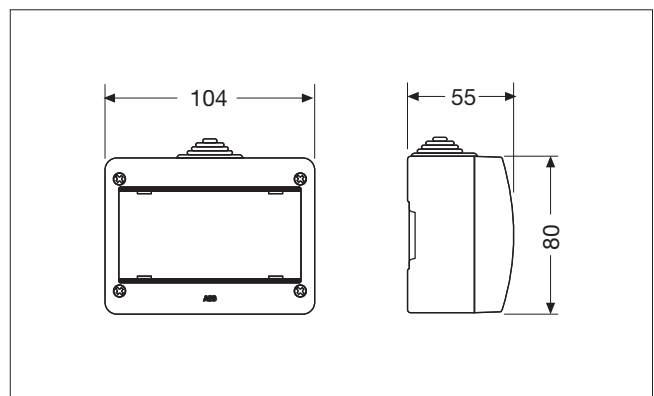
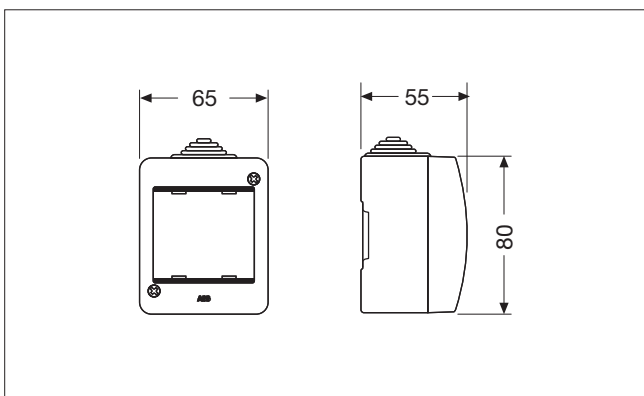

Centralizations

Surface mounting box

Ref.	A	B	C	D	E
T1292	212	204	55	117	121
T1293	212	275	55	188	121
T1294	212	346	55	259	121

Flush-mounting box

Ref.	A	B	C	D	E
T1092.1	186	178	55	-	-
T1093.1	186	249	55	-	-
T1094.1	186	320	55	-	-

Workstations

Surface mounting box

Ref.	A	B	C	D	E
T1193	235	176	45	83	146
T1194	295	176	45	83	206
T1195	355	176	45	83	266

Flush-mounting box

Ref.	A	B	C	D	E
T1093	211	150	42	-	-
T1094	271	150	42	-	-

Floor boxes T1393 y T1393.1

Floor box

Hollow to be done: 273 x 209

Metallic housing T1393.9

Adapter frame T1371.4

Note: all dimensions in mm.

Mounting boxes

1099/1199

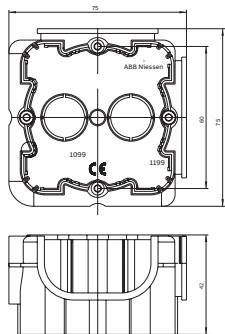

999

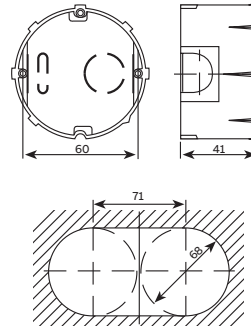

999.2

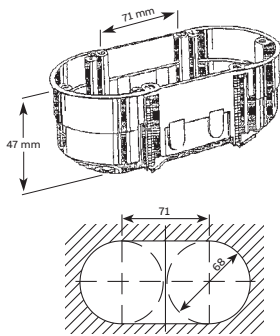

499.3

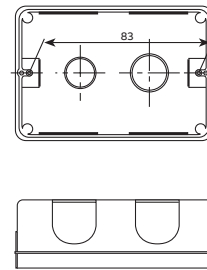

1499.4

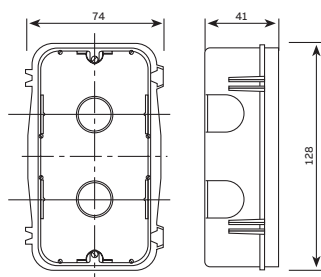

1499.7

