

THIS COPY IS PROVIDED ON A RESTRICTED BASIS AND IS NOT TO BE USED IN ANY WAY DETRIMENTAL TO THE INTERESTS OF PANDUIT CORP.

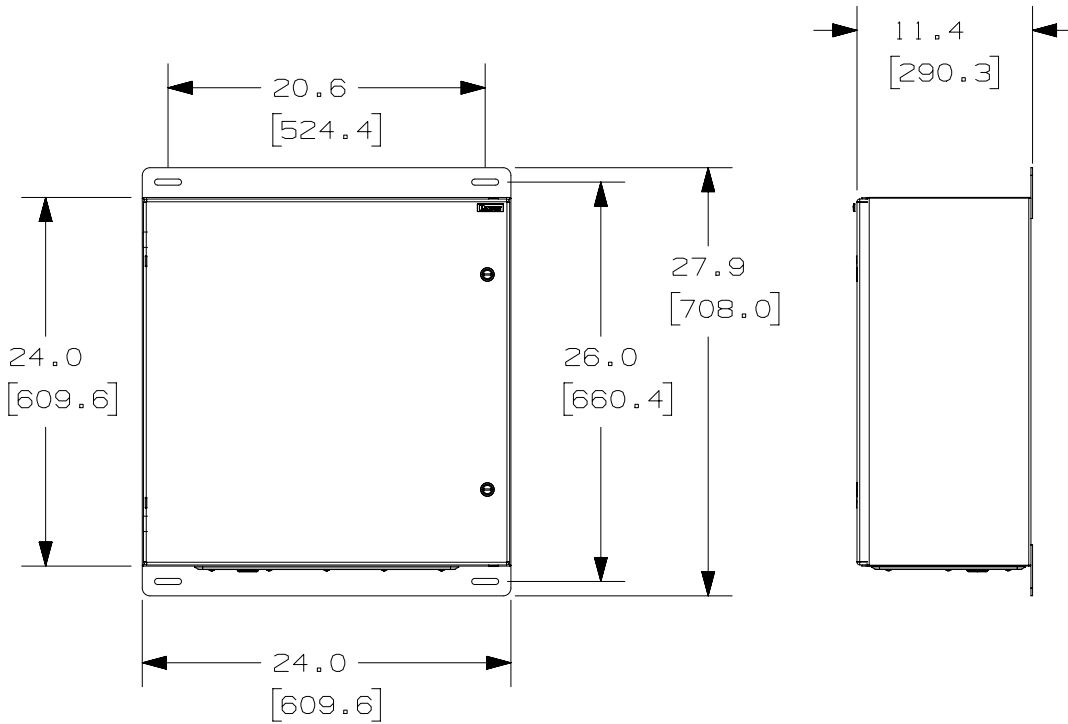

WIDTH	HEIGHT	DEPTH	WEIGHT
24.0"	24.0"	11.6"	80 LBS / 36 KG

PART NUMBER	ENCLOSURE TYPE	STEEL GAUGE
FTE24A1A16	316L STAINLESS STEEL	16 GAUGE STEEL
FTE24A1A1	STEEL	16 GAUGE STEEL

NOTES:

- DIMENSIONS IN PARENTHESES ARE IN METRIC.
- ENCLOSURE INCLUDES:
 - (2) CABLE MANAGEMENT SIDE PANELS
 - (1) BLANK GLAND PLATE FOR CABLE ENTRY AND EXIT
 - (1) 1/2" CONDUIT PLUG FOR POWER ENTRY
 - (1) UNIVERSAL GROUND BAR
 - (2) EXTERNAL MOUNT FLANGES
 - (1) BASE PLATE
 - (5) FOSM MOUNTING BRACKETS
 - (15) PANDUIT FIBER OPTIC SPLICE MODULE, PART NUMBER FOSMF
 - (4) SLACK MANAGER SPOOLS, PART NUMBER PRSP5
 - (4) ARMORED CABLE GROUNDING KITS
 - (1) INFRASTRUCTURE GROUND CABLE
 - (2) KEVLAR STRAND CLAMPS
- ENCLOSURES CAN MANAGE 3 METERS OF CABLE SLACK
- ENCLOSURES CAN HOUSE (15) FIBER OPTIC SPLICE MODULES (FOSMs)
- ENCLOSURES CAN RECEIVE AND HOUSE (1) TRUNK OF UP TO 360 FIBERS
- ALL ENCLOSURES COMPLY WITH UL 508A STANDARDS
- ALL ENCLOSURES ARE NEMA TYPE 4/12 AND IP66 RATED
- THE ENCLOSURE IS WALL MOUNTABLE WITH THE OPTION TO USE OUTSIDE EXTERNAL MOUNT FLANGES
- 316 STAINLESS STEEL ENCLOSURES ARE RATED NEMA 4X

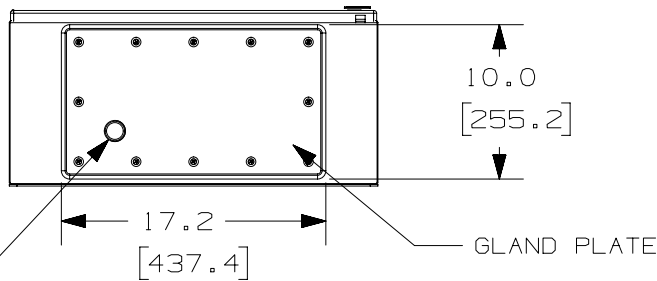

TITLE		FIBER SPLICE ENCLOSURE	
ITEM REVISION NAME		CUSTOMER DRAWING	
00044EAC/01		PANDUIT	
DATASET FILE NAME			
00044EAC_DC/01A		MATERIAL:	
UNLESS OTHERWISE SPECIFIED, DIMENSIONAL TOLERANCES ARE: IN [mm]		N/A	
.x ± .1 [2.54] .xxx ± .005 [.127]		DRAWING NUMBER:	
.xx ± .01 [.25] ANGLES ± 5 °		00044EAC_DC	
THIRD ANGLE PROJECTION		SHT 1 OF 2	
DRAWN BY	DATE	CHK	SCALE
ADS	3/4/19	EHA	NONE
REV	DATE	BY	DESCRIPTION
01A	8/20/19	ADS	RELEASED TO CUSTOMER
ECN	00044EAC		

D10100DA/14

THIS COPY IS PROVIDED ON A RESTRICTED BASIS AND IS NOT TO BE USED IN ANY WAY DETRIMENTAL TO THE INTERESTS OF PANDUIT CORP.

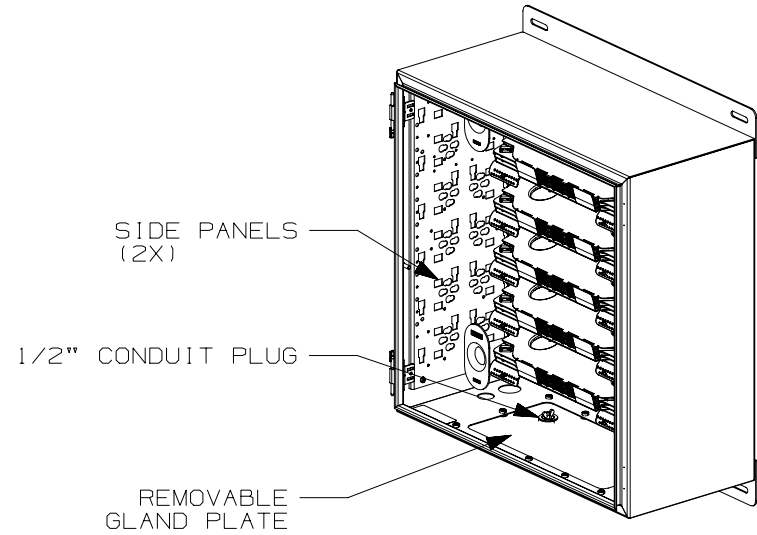
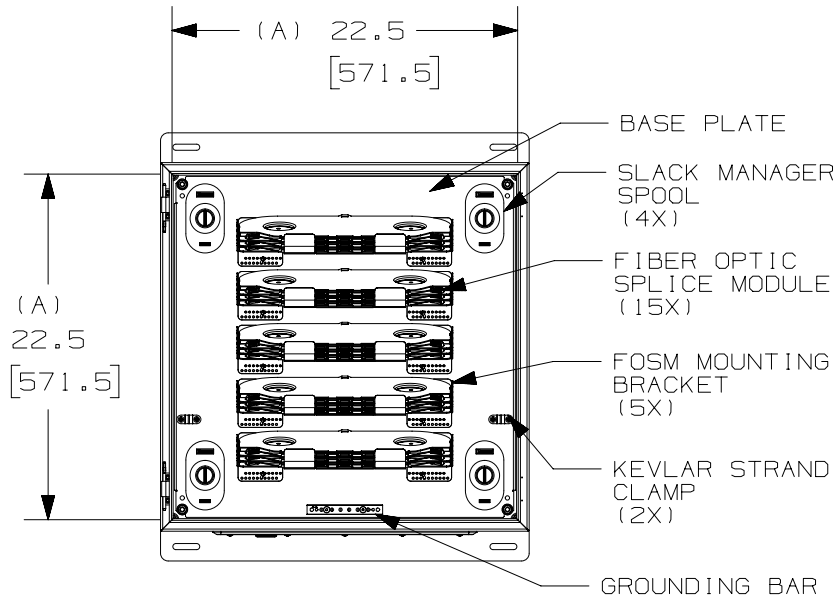

(A) DIRECT WALL MOUNT HOLE LOCATIONS
DOOR REMOVED FOR CLARITY

TITLE		FIBER SPLICE ENCLOSURE	
ITEM REVISION NAME		CUSTOMER DRAWING	
00044EAC/01		PANDUIT	
DATASET FILE NAME			
00044EAC_DC/01A		MATERIAL:	
UNLESS OTHERWISE SPECIFIED, DIMENSIONAL TOLERANCES ARE: IN [mm]		N/A	
.x ± .1 [2.54] .xxx ± .005 [.127]		DRAWING NUMBER: 00044EAC_DC	
.xx ± .01 [.25] ANGLES ± 5 °			
THIRD ANGLE PROJECTION		SHT 2 OF 2	
DRAWN BY	DATE	CHK	SCALE
ADS	3/5/19	EHA	NONE
REV	DATE	BY	CHK
01A	8/20/19	ADS	EHA
ASAP	APR	DESCRIPTION	
REFER TO SHEET 1 FOR REVISION CONTROL	ECN		00044EAC

D10100DA/14