

THIS COPY IS PROVIDED ON A RESTRICTED BASIS AND IS NOT TO BE USED IN ANY WAY DETRIMENTAL TO THE INTERESTS OF PANDUIT CORP.

PANDUIT PART NUMBER	COPPER CONDUCTOR RANGE	DIMENSIONS - IN [mm] ±.1 [2.5]			BOLT DIA
		L	W	H	
GBC2250-12-X	2/0 STR - 250 kcmil	2.04 [52]	1.25 [32]	2.27 [58]	1/2"
GBC4300-12-X	4 STR - 300 kcmil	2.16 [55]	1.38 [35]	2.82 [72]	1/2"
GBC3500-12-X	300 kcmil - 500 kcmil	2.69 [68]	1.64 [42]	2.82 [72]	1/2"

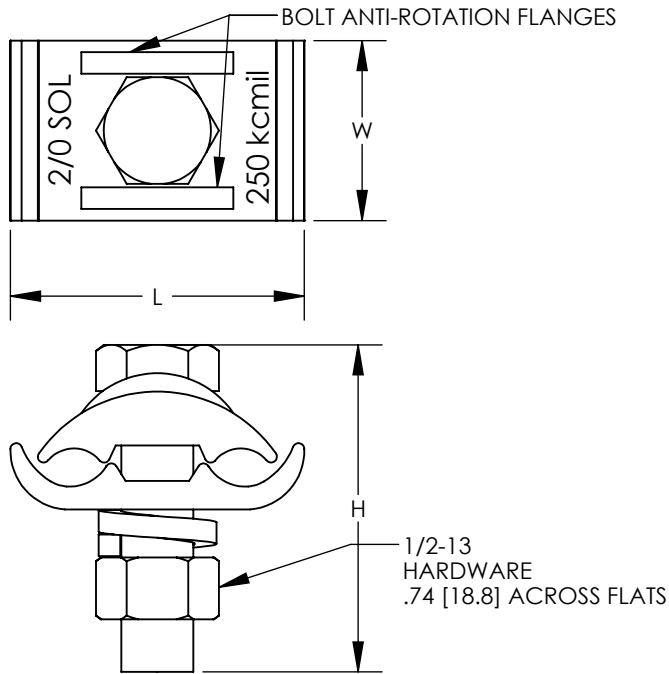

NOTES:

1. MATERIAL:  
-BODY - HIGH COPPER CONTENT ALLOY  
-HARDWARE - SILICON BRONZE
2. PARTS ARE cULus LISTED TO UL467/CSA22.22 No. 41 AS GROUNDING AND BONDING EQUIPMENT.
3. CONNECTORS ACCOMODATE TWO EQUAL DIAMETER CONDUCTORS IN THE RANGE SPECIFIED.
4. ACCOMODATES BAR THICKNESS OF 0.250 [6.35] MAX.
5. RATED FOR DIRECT BURIAL
6. SEE PACKAGING LABEL FOR TIGHTENING TORQUE SPECIFICATIONS.
7. DIMENSIONS IN PARENTHESIS ARE MILLIMETERS.
8. PKG. QTY. = 10



DB  
RATED

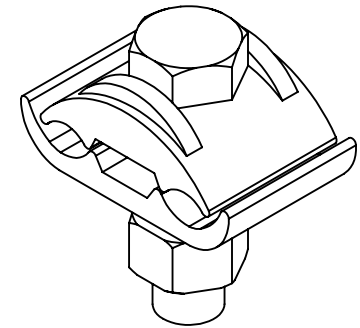

REV	DATE	BY	CHK	APR	DESCRIPTION	ECN
03	7/18	JHNU	BKR	RGB	ADDED GBC4300-12-X, GBC3500-12-X	038340
02	1/16	JHNU	BKR	RGB	ADDED PACKAGING QTY. TO PART NUMBER	13J051AL-DC
01	1/16	JHNU	BKR	RGB	REVISED NOTE 2: REMOVED 13	13J051AL-DC
00	10/15	JHNU	BKR	RGB	DRAWING RELEASED	13J051AL-DC

TITLE		GROUND BAR CLAMP CUSTOMER DRAWING	
ITEM REVISION NAME	13J051AL/03		
DATASET FILE NAME	13J051AL-DC/03.SLDDRW		
UNLESS OTHERWISE SPECIFIED, DIMENSIONAL TOLERANCES ARE: IN [mm]		MATERIAL	
.X ±	.XXX ±	SEE NOTES	
.XX ±	ANGLES ±	DRAWING NUMBER	
THIRD ANGLE PROJECTION		13J051AL-DC	
DRAWN BY	DATE	CHK	SCALE
JHNU	4/15	BKR	N/A
SHEET 1 OF 1			SIZE A