

# PANDUIT NET-ACCESS N-Type Network Cabinets

(Vertical Blanking Panels NVBP)

## INSTRUCTIONS CM627B

© Panduit Corp. 2013-2014

### Vertical Blanking Panel Installation

- Install 102mm (4in) Bulb Seal to the top of both top Vertical Blanking Panel assemblies. (shown in fig A)
- Install 26.5mm (1.0in) Bulb Seal to the top side of both top Vertical Blanking Panel assemblies. (shown in fig B)
- Insert 35mm (1.4in) Foam Seal into the top of the C channel of the top Vertical Blanking Panel assemblies and into the bottom of the C channel of the bottom Vertical Blanking Panel assemblies. (shown in fig B)
- Install Foam Seal on the bottom flange of the caster seal brackets .
- Install (2) Caster Seal Brackets (1 Left, 1 Right) to the bottom air dam assemblies using (1) M5X0.8 button head torx screw per side. (do not tighten\*).
- Install bottom Vertical Blanking Panel assemblies to the frame using (4) M5X0.8 button head torx screws. *Do not tighten (2) top screws.*
- Insert top Vertical Blanking Panel assemblies to the frame using (3) M5X0.8 button head torx screws. Slide the top Vertical Blanking Panel assembly over the bottom Vertical Blanking Panel assembly. Line up the corresponding hole (shown in fig D) with the top screw of the bottom Vertical Blanking Panel assembly. Tighten (2) top screws of bottom Vertical Blanking Panel.
- Attach the long Flap Seal to the outside flange of the Vertical Blanking Panel. Start at the top closing any gaps between the top cap and the Vertical Blanking Panel.(shown in fig E and fig F on page 2)
- Attach Equipment Seal to the lower side to side beam and to the upper side to side beam, between the front E-rails.(shown in fig G on page 2)
- Install foam seal to the underside of the front side to side beam. (shown in fig H on page 2)

\*When cabinet is level adjust caster seal brackets to create an air tight seal to the floor. Tighten screws

\*Note: Seal any remaining air gaps with Blanking Foam Seal

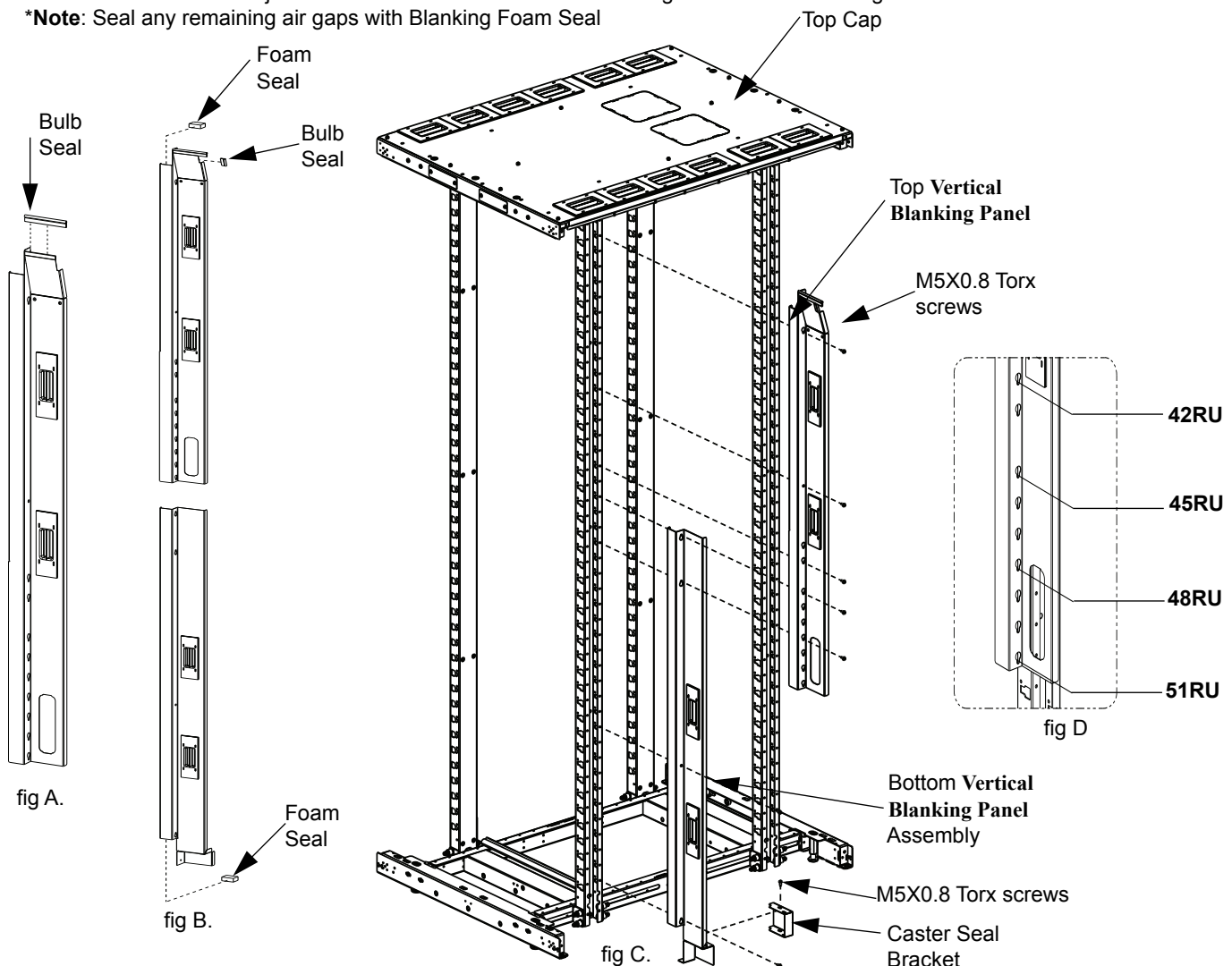

FOR TECHNICAL SUPPORT [www.panduit.com/resources/install\\_maintain.asp](http://www.panduit.com/resources/install_maintain.asp)

INSTRUCTIONS CM627B

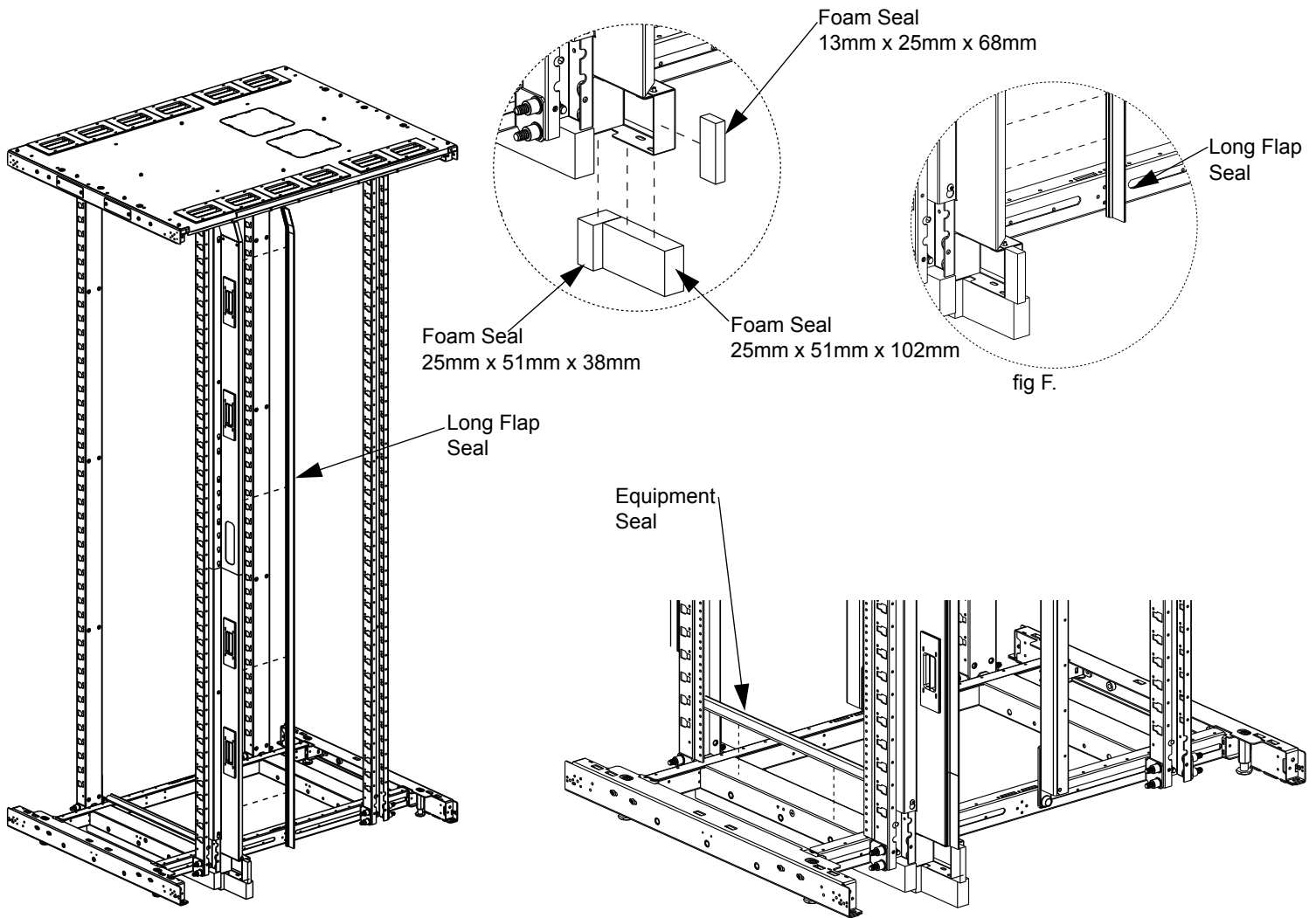

fig E.

fig G.

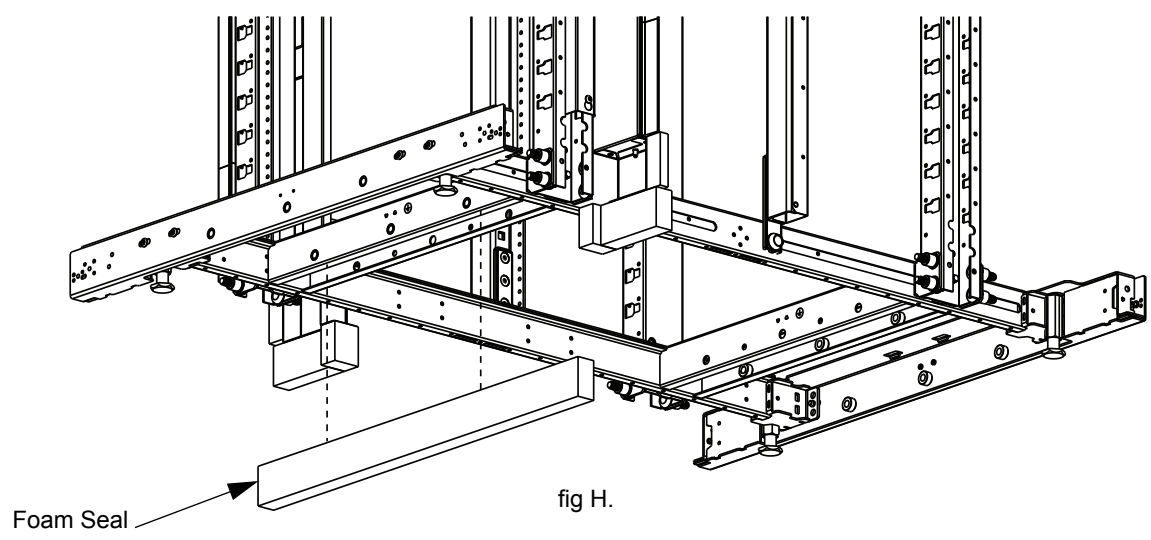

fig H.

### Blanking Seal Bracket Installation

Attach the Blanking Seal Bracket to the Bottom Vertical Blanking Panel using [2] M5 Torx Screws

Apply Foam Seal to the bottom of the Blanking Seal Bracket to ensure an air tight seal.

**Note:** This only applies when (2) two cabinets without Side Panels are ganged together.

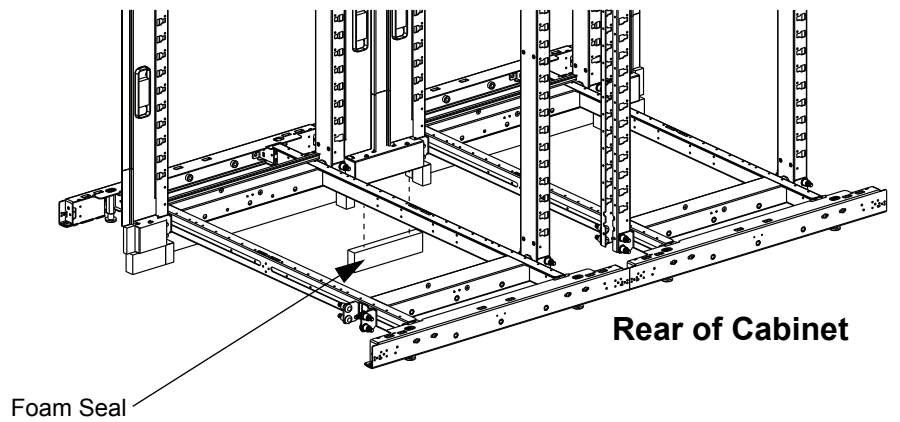
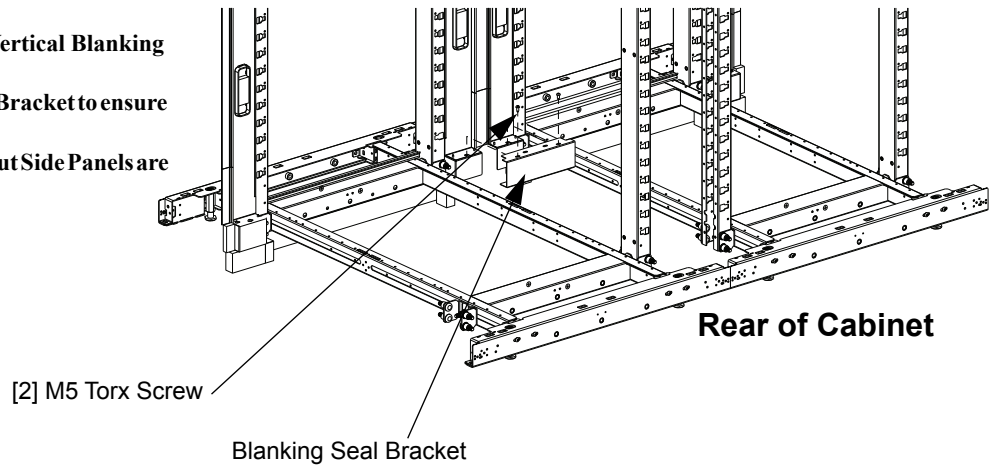

### Top Cabinet to Cabinet Gap Sealing Installation

-Air Gap between top cap and Blanking Panels should be sealed with Blanking Foam Seal

