

Description	Code	Masse/Weight Kg/p	Ep./Th. mm	daN
CRAPAUD S100U SZ	677790	0,150	4,00	20

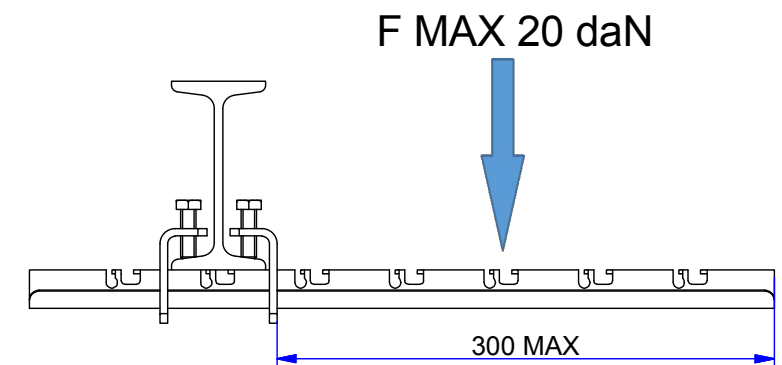

G : Pre-galvanised according to NF EN 10346 (S220 GD / Z).

SZ : Tôle d'acier galvanisé avant fabrication suivant NF EN 10346 (S220 GD / Z).



www.niedaxfrance.fr

CRAPAUD S100U SZ
RAIL CLIP S100 U G



ASSISTANCE TECHNIQUE
+33 (0)1 55 95 92 17
pole.technique@niedax.fr

FT03336

NIEDAX
France

