



# AGM LEAD ACID BATTERY

## S 6V-1.2Ah FR

AGM  
STANDARD

### MAIN INFORMATION / INFORMATIONS GÉNÉRALES

<b>BRAND / MARQUE</b>	NX
<b>TECHNOLOGY / TECHNOLOGIE</b>	AGM Lead acid
<b>NOMINAL VOLTAGE / TENSION NOMINALE</b>	6V
<b>NOMINAL CAPACITY / CAPACITÉ NOMINALE</b>	1.2Ah (20hr)
<b>DIMENSIONS ( ± 2 mm) / DIMENSIONS ( ± 2 mm)</b>	
• <b>Length / Longueur</b>	97 ± 1 mm (3.82 inches)
• <b>Width / Largeur</b>	24 ± 1 mm (0.94 inches)
• <b>Height / Hauteur</b>	51.5 ± 1 mm (2.03 inches)
• <b>Total height with terminals / Hauteur totale (avec cosses)</b>	57.5 ± 1 mm (2.26 inches)
<b>WEIGHT ( ± 2 %) / POIDS ( ± 2 %)</b>	Approx 0.29kg (0.64lbs)
<b>TERMINAL / TYPE DE COSSES</b>	T1
<b>CASING / TYPE DE BAC</b>	UL94 V-0 (Flame retardant)
<b>COLOR / COULEUR DE BAC</b>	Black top and black case



### TECHNICAL INFORMATION / INFORMATIONS TECHNIQUES

<b>CAPACITY / CAPACITÉ</b>	1.20Ah/0.060A (20hr,1.80V/cell,25°C/77°F) 1.12Ah/0.112A (10hr,1.80V/cell,25°C/77°F) 1.01Ah/0.202A (5hr,1.75V/cell,25°C/77°F) 0.882Ah/0.294A (3hr,1.75V/cell,25°C/77°F) 0.728Ah/0.728A (1hr,1.60V/cell,25°C/77°F)
<b>DISCHARGE CURRENT / COURANT DE DÉCHARGE</b>	18A (5s)
<b>INTERNAL RESISTANCE / RÉSISTANCE INTERNE</b>	Approx 65mΩ
<b>OPERATING TEMPERATURE RANGE / PLAGES DE TEMPÉRATURE</b>	
• <b>Discharging / Décharge</b>	-15°~50°C (5 ~122°F)
• <b>Charging / Charge</b>	0°~40°C (32 ~104°F)
• <b>Storage / Stockage</b>	-15°~40°C (5 ~104°F)
<b>NOMINAL OPERATING TEMPERATURE / TEMPÉRATURE D'UTILISATION</b>	25 ± 3°C (77 ± 5°F)
<b>CAPACITY VS TEMPERATURE / CAPACITÉ SELON LA TEMPÉRATURE</b>	40°C (104°F) 103% 25°C (77°F) 100% 0°C (32°F) 86%

#### T1 / Terminal

Unité : mm / Unit: inches

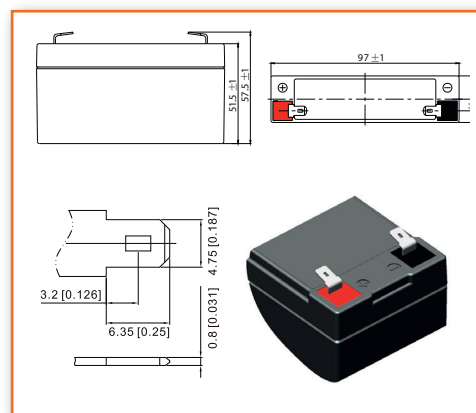

### APPLICATIONS

- All purpose / Tout usage
- UPS / Onduleur
- Emergency light / Éclairage de secours
- Railway signal / Signalisation ferroviaire
- Alarm and security system / Alarme et sécurité
- Aircraft signal / Signal d'avion
- Electronic devices and equipment / Appareils et équipements électroniques
- Emergency backup / Alimentation de secours
- Power supply / Réserve d'énergie



**CONSTANT CURRENT DISCHARGE (AMPERES) AT 25°C**  
**TABLE DE DÉCHARGE À COURANT ET PUISSANCE CONSTANTS (A) À 25°C**

F.V/Temp	5min	10min	15min	20min	30min	45min	1h	2h	3h	4h	5h	6h	8h	10h	20h
1.85V/cell	2.30	1.61	1.32	1.15	0.922	0.709	0.580	0.354	0.270	0.222	0.188	0.163	0.130	0.108	0.059
1.80V/cell	2.83	1.92	1.54	1.30	1.02	0.773	0.624	0.376	0.284	0.233	0.196	0.170	0.134	0.112	0.060
1.75V/cell	3.36	2.17	1.69	1.41	1.09	0.821	0.656	0.392	0.294	0.240	0.202	0.174	0.138	0.114	0.061
1.70V/cell	3.81	2.39	1.83	1.52	1.14	0.853	0.684	0.409	0.303	0.246	0.207	0.179	0.140	0.116	0.062
1.65V/cell	4.20	2.57	1.94	1.59	1.19	0.886	0.713	0.421	0.0311	0.251	0.211	0.182	0.142	0.117	0.063
1.60V/cell	4.41	2.68	2.02	1.65	1.23	0.906	0.728	0.434	0.318	0.258	0.216	0.186	0.145	0.119	0.063

**CONSTANT POWER DISCHARGE (WATTS) AT 25°C**  
**DÉCHARGE À PUISSANCE CONSTANTE (WATTS) À 25°C**

F.V/Temp	5min	10min	15min	20min	30min	45min	1h	2h	3h	4h	5h	6h	8h	10h	20h
1.85V/cell	4.35	3.06	2.55	2.23	1.80	1.39	1.14	0.701	0.536	0.442	0.377	0.327	0.261	0.217	0.120
1.80V/cell	5.28	3.61	2.93	2.50	1.98	1.51	1.22	0.741	0.560	0.462	0.390	0.339	0.269	0.224	0.121
1.75V/cell	6.18	4.05	3.20	2.70	2.10	1.59	1.28	0.768	0.577	0.474	0.399	0.345	0.274	0.226	0.121
1.70V/cell	6.93	4.42	3.43	2.88	2.19	1.64	1.33	0.796	0.592	0.483	0.406	0.352	0.277	0.229	0.122
1.65V/cell	7.54	4.69	3.59	2.99	2.26	1.70	1.37	0.814	0.604	0.490	0.413	0.357	0.280	0.231	0.124
1.60V/cell	7.79	4.82	3.70	3.05	2.30	1.72	1.39	0.834	0.615	0.499	0.419	0.362	0.284	0.234	0.124

**DISCHARGE CHARACTERISTICS**  
**CARACTÉRISTIQUES DE DÉCHARGE**

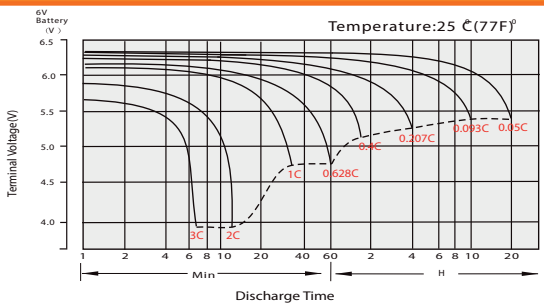

**FLOAT CHARGING CHARACTERISTICS**  
**CARACTÉRISTIQUES DE CHARGE EN FLOATING**

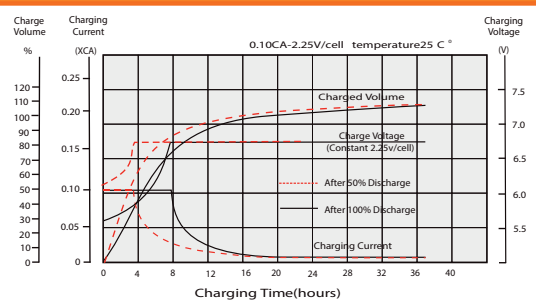

**TEMPERATURE EFFECTS IN RELATION TO BATTERY CAPACITY**  
**EFFET DE LA TEMPÉRATURE SUR LA BATTERIE**

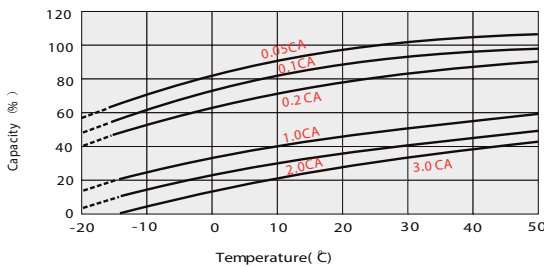

**EFFECT OF TEMPERATURE ON LONG TERM FLOAT LIFE**  
**EFFET DE LA TEMPÉRATURE SUR LA DURÉE DE VIE EN FLOATING**

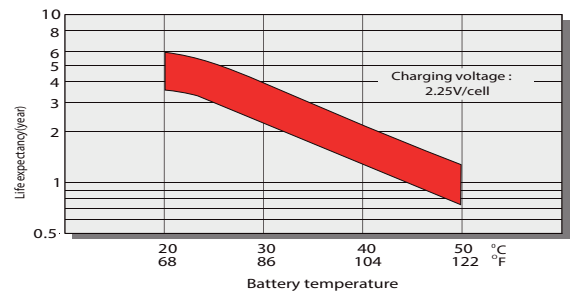

**CYCLE LIFE IN RELATION TO DEPTH OF DISCHARGE**  
**CYCLE DE VIE EN FONCTION DE LA PROFONDEUR DE LA DÉCHARGE**

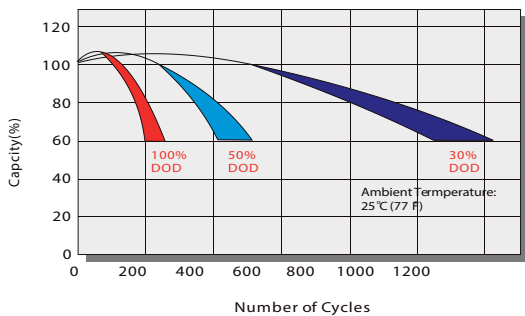

**SELF DISCHARGE CHARACTERISTICS**  
**RELATION ENTRE LA CAPACITÉ ET LE TEMPS DE STOCKAGE**

