

THIS COPY IS PROVIDED ON A RESTRICTED BASIS AND IS NOT TO BE USED IN ANY WAY DETRIMENTAL TO THE INTERESTS OF PANDUIT CORP.

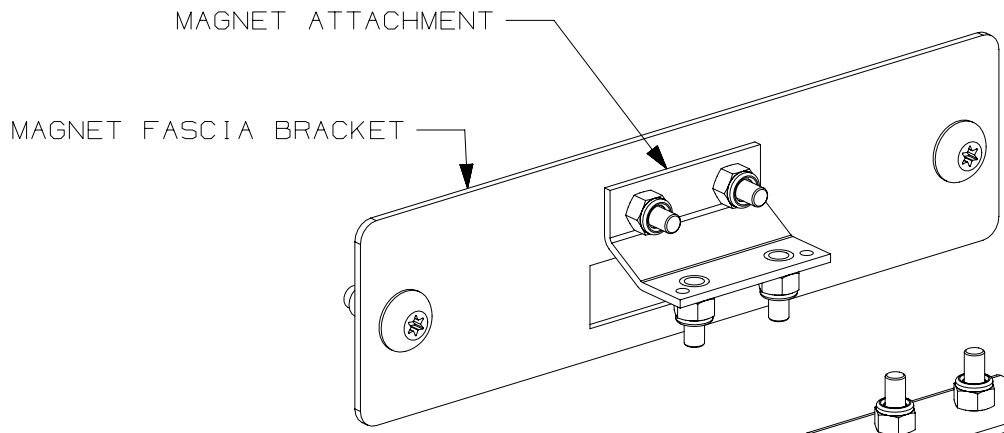

PANDUIT P/N	COLOR
MA015	BLACK
MA015W	WHITE
MA015G	GRAY

- NOTES:
- VISIT OUR ON-LINE CATALOG AT WWW.PANDUIT.COM FOR A LIST OF CURRENT PARTS APPLICABLE FOR USE WITH THIS PRODUCT.
 - PRIMARY DIMENSIONS ARE IN MILLIMETERS (mm), SECONDARY DIMENSIONS IN [INCHES].
 - PARTS SUPPLIED:
 (1)- MAGNET ATTACHMENT
 (1)- MAGNET FASCIA BRACKET
 (1)- MAGNETIC SWITCH DOOR BRACKET
 (1)- MAGNETIC SWITCH BRACKET CLAMP
 (2)- M5X0.8 BUTTON HEAD SCREWS
 (6)- M3X0.5 NYLON INSERT LOCKNUT
 (4)- M5X0.8 SERRATED FLANGE HEX NUT
 - WEIGHT:
 0.13 kg/EACH
 .29 LBS/EACH

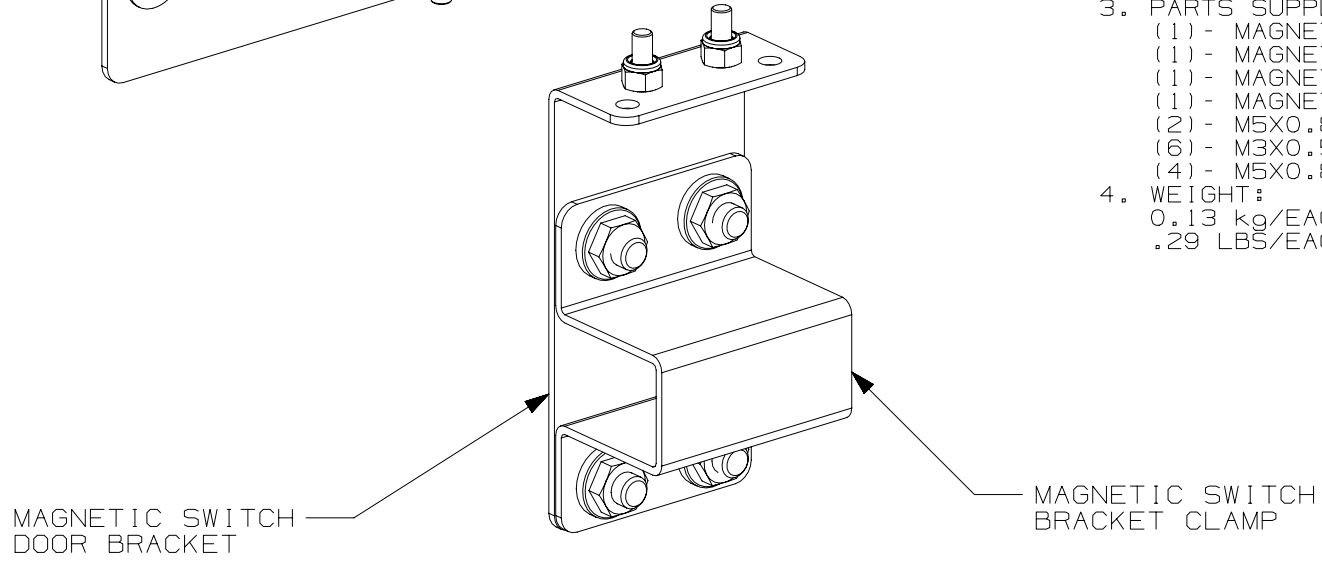

REV	DATE	BY	CHK	APR	DESCRIPTION	ECN
01A	03-09-18	NILI	DACU	EDM	RELEASED FOR PRODUCTION	15V120AB
00A	11-28-17	LEE	BAO		RELEASED FOR QUOTE	V09001KZ

TITLE		FRONT DOOR SWITCH SENSOR BRACKET (MA015) CUSTOMER DRAWING	
ITEM REVISION NAME		15V120AB/01	
DATASET FILE NAME		15V120AB_DC/01A	
MATERIAL:		N/A	
DRAWING NUMBER:		15V120AB_DC	
DRAWN BY	DATE	CHK	SCALE
LEE	11-28-17	BAO	NONE
THIRD ANGLE PROJECTION		SHT 1 OF 1	
SIZE		A	

D10100DA/16