

Lexium P Robot

Hardware Guide

Original instructions

EIO0000002173.13

12/2021

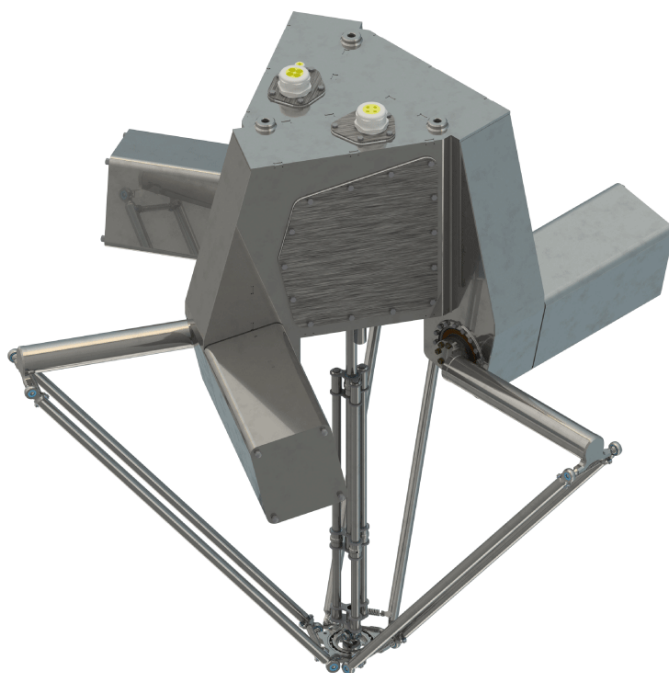

Legal Information

The Schneider Electric brand and any trademarks of Schneider Electric SE and its subsidiaries referred to in this guide are the property of Schneider Electric SE or its subsidiaries. All other brands may be trademarks of their respective owners.

This guide and its content are protected under applicable copyright laws and furnished for informational use only. No part of this guide may be reproduced or transmitted in any form or by any means (electronic, mechanical, photocopying, recording, or otherwise), for any purpose, without the prior written permission of Schneider Electric.

Schneider Electric does not grant any right or license for commercial use of the guide or its content, except for a non-exclusive and personal license to consult it on an "as is" basis. Schneider Electric products and equipment should be installed, operated, serviced, and maintained only by qualified personnel.

As standards, specifications, and designs change from time to time, information contained in this guide may be subject to change without notice.

To the extent permitted by applicable law, no responsibility or liability is assumed by Schneider Electric and its subsidiaries for any errors or omissions in the informational content of this material or consequences arising out of or resulting from the use of the information contained herein.

As part of a group of responsible, inclusive companies, we are updating our communications that contain non-inclusive terminology. Until we complete this process, however, our content may still contain standardized industry terms that may be deemed inappropriate by our customers.

© 2021 Schneider Electric. All Rights Reserved.

Table of Contents

About the Book.....	8
Hazard Information	12
Proper Use	12
Qualification of Personnel.....	14
Residual Risks.....	14
System Overview	22
System Architecture.....	22
Product Overview	23
Type Code.....	26
Type Plate.....	28
Technical Data	30
Ambient Conditions.....	30
Ambient Conditions	30
Mechanical and Electrical Data of Lexium P Robots	31
Robot VRKP0•••WF.....	31
Robot VRKP0•••NC	32
Robot VRKP0•••WF••E00	34
Robot VRKP0•••NC••E00.....	35
Robot VRKP1•••WF.....	37
Robot VRKP1•••NC	38
Robot VRKP1•••WF••E00	40
Robot VRKP1•••NC••E00.....	41
Robot VRKP2•••WD	43
Robot VRKP2•••NC	44
Robot VRKP4•••WD / VRKP4•••NO / VRKP4•••CW.....	46
Robot VRKP4•••WF.....	47
Robot VRKP4•••NC.....	49
Robot VRKP5•••WF.....	50
Robot VRKP5•••NC.....	52
Robot VRKP6•••WF.....	53
Robot VRKP6•••NC.....	55
Robot VRKP6•••WF••E00	56
Robot VRKP6•••NC••E00.....	57
Dimensional Drawings.....	59
Dimensional Drawing of the Lexium P Robot	59
Detail Drawing of the Main Body of VRKP•S0•NC	62
Detail Drawing of the Main Body of VRKP•L0•NC	64
Detail Drawing of the Main Body of VRKP•S0•WF	66
Detail Drawing of the Main Body of VRKP•S0•WD / VRKP•S0•CW	69
Detail Drawing of the Main Body of VRKP•L0•WD / VRKP•L0•NO.....	72
Detail Drawing of the Upper Arm	74
Detail Drawing of the Lower Arm	76
Detail Drawing of the Telescopic Axis.....	78
Electrical Connections.....	79
Electrical Connections	79
Performance Data.....	81

Typical Cycle Time	81
Load Capacity Diagram	89
Positioning Performance.....	90
Design of the Robot Frame	91
Design of the Robot Frame	91
Run-On Motions of the Robot for Risk Analysis	94
Run-On Motions of the Robot for Risk Analysis.....	94
Technical Data of the Motor and the Gearbox	102
Technical Data of the Motor and the Gearbox	102
Transport and Commissioning	104
Transport and Unpacking	104
Transport and Storage.....	104
Unpacking	104
Mechanical Installation	107
Information About Installation	107
Mounting the Robot	108
Electrical Installation	110
Opening the Robots VRKP••••WD / VRKP••••NO / VRKP••••CW /	
VRKP••••WF for Cabling	110
Cabling the VRKP•S0•WD / VRKP•S0•CW.....	111
Cabling the VRKP•S0•WF	115
Cabling the VRKP•S0•NC	119
Cabling the VRKP•L0•WD / VRKP•L0•NO	120
Cabling the VRKP•L0•NC	122
Grounding the Robot	123
Closing the Robot.....	126
Reducing Risks Around the Robot	127
Initial Start-Up.....	128
Allocation of the Sercos Addresses.....	128
Parametrization of the Robot Mechanics	128
Verifying the Calibration and Motor Direction	128
Mounting the Telescopic Axis on Robots with a Rotational	
Axis.....	131
Mounting the Lower Arms	133
Mounting the Module on Robots with Motorized Modules	137
Verifying the Coordinate System of the Robot.....	137
Setting the Monitoring.....	138
Start-Up	138
Mounting the Payload.....	140
Mounting the Gripper.....	140
Supply of the Gripper.....	143
Optional Equipment	145
Impact Plate	145
Product Overview of the Impact Plate	145
Mounting the Impact Plate	145
Gearbox Leakage Protection	146
Product Overview of the Gearbox Leakage Protection.....	146
Mounting the Gearbox Leakage Protection.....	147
Parallel Plate Ball Bearing Protection	148
Product Overview of the Parallel Plate Ball Bearing	
Protection	148

Mounting the Parallel Plate Ball Bearing Protection	149
Mounting the Gripper to the Parallel Plate Ball Bearing Protection	151
Telescopic Axis Double	153
Technical Data of the Telescopic Axis Double	153
Mounting the Telescopic Axis Double	155
Rotational Modules	157
Product Overview of the Rotational Modules	157
Technical Data of the Rotational Modules	158
Mounting the Rotational Modules	160
Cabling the Rotational Modules	160
Mounting the Payload to the Rotational Modules	163
Tilting Modules	165
Product Overview of the Tilting Modules.....	165
Technical Data of the Tilting Modules	166
Mounting the Tilting Modules.....	168
Cabling the Tilting Modules	168
Mounting the Payload to the Tilting Modules.....	168
Double Rotational Modules.....	173
Product Overview of the Double Rotational Modules	173
Technical Data of the Double Rotational Modules	174
Mounting the Double Rotational Modules	177
Cabling the Double Rotational Modules	177
Mounting the Payload to the Double Rotational Modules	179
Rotational Tilting Modules.....	184
Product Overview of the Rotational Tilting Modules.....	184
Technical Data of the Rotational Tilting Modules	185
Mounting the Rotational Tilting Modules	188
Cabling the Rotational Tilting Modules	188
Mounting the Payload to the Rotational Tilting Modules	188
Maintenance and Repair	195
Maintenance, Repair, and Cleaning.....	195
General Information About Maintenance, Repair, and Cleaning.....	195
Maintenance Plan	196
Maintaining the Telescopic Axis	197
Maintaining the Springs	197
Maintaining the Slide Films	198
Maintaining the Rolls on the Spring Pack of the Lower Arm	198
Maintaining the Ball Sockets	198
Maintaining the Universal Joints	199
Maintaining the Ball Pins.....	199
Maintaining the Fans	200
Maintaining the Motor (Optional Equipment).....	200
Maintaining the Gearbox.....	200
Cleaning.....	200
Repairing After Collisions.....	202
Replacing Parts	203
Information About Replacing Parts	203
Replacing the Telescopic Axis	204
Replacing the Universal Joints	205

Replacing the Plain Bearings	206
Replacing the Slide Films.....	208
Replacing the Motor or the Gearbox on the Rotational Axis	211
Replacing the Lower Arms	214
Replacing the Ball Sockets.....	215
Replacing the Springs	215
Replacing the Rolls on the Lower Arms.....	216
Replacing the Parallel Plate	217
Replacing the Upper Arms	218
Replacing the Protector Cap	219
Replacing the Motor or the Gearbox on the Main Axis	220
Replacing the Ball Pins	226
Replacing the Fans	227
Replacing the Gearbox Leakage Protection (Optional Equipment).....	227
Replacing the Motorized Module	228
Calibration.....	228
Calibration of the Robot Mechanics	228
Calibrating the Main Axes	229
Calibrating the Rotational Axis.....	232
Calibrating the Double Rotational Module or the Rotational Tilting Module (Optional Equipment).....	232
Calibrating the Tilting Module (Optional Equipment).....	234
Replacement Equipment and Accessories.....	235
Replacement Equipment Inventory.....	235
Standard Replacement Equipment.....	238
Optional Equipment and Accessories	244
Troubleshooting	248
Troubleshooting.....	248
Appendices	249
Further Information About the Manufacturer.....	250
Contact Addresses.....	250
Product Training Courses	250
Disposal	251
Disposal.....	251
Declaration of Incorporation.....	252
Declaration of Incorporation	253
Index	255

Safety Information

Important Information

Read these instructions carefully, and look at the equipment to become familiar with the device before trying to install, operate, service, or maintain it. The following special messages may appear throughout this documentation or on the equipment to warn of potential hazards or to call attention to information that clarifies or simplifies a procedure.



The addition of this symbol to a “Danger” or “Warning” safety label indicates that an electrical hazard exists which will result in personal injury if the instructions are not followed.



This is the safety alert symbol. It is used to alert you to potential personal injury hazards. Obey all safety messages that follow this symbol to avoid possible injury or death.

DANGER

DANGER indicates a hazardous situation which, if not avoided, **will result in** death or serious injury.

WARNING

WARNING indicates a hazardous situation which, if not avoided, **could result in** death or serious injury.

CAUTION

CAUTION indicates a hazardous situation which, if not avoided, **could result in** minor or moderate injury.

NOTICE

NOTICE is used to address practices not related to physical injury.

Please Note

Electrical equipment should be installed, operated, serviced, and maintained only by qualified personnel. No responsibility is assumed by Schneider Electric for any consequences arising out of the use of this material.

A qualified person is one who has skills and knowledge related to the construction and operation of electrical equipment and its installation, and has received safety training to recognize and avoid the hazards involved.

About the Book

Document Scope

This manual is to help you use the capabilities of the robot safely and properly.

Follow the instructions within this manual to help:

- Reduce risks
- Reduce repair costs and downtime of the robot
- Increase the service life of the robot
- Increase the reliability of the robot

Validity Note

This document has been updated for the release of EcoStruxure™ Machine Expert V2.0.2.

The characteristics that are described in the present document, as well as those described in the documents included in the Related Documents section below, can be found online. To access the information online, go to the Schneider Electric home page www.se.com/ww/en/download/.

The characteristics that are described in the present document should be the same as those characteristics that appear online. In line with our policy of constant improvement, we may revise content over time to improve clarity and accuracy. If you see a difference between the document and online information, use the online information as your reference.

For product compliance and environmental information (RoHS, REACH, PEP, EOL, etc.), go to www.se.com/ww/en/work/support/green-premium/.

Related Documents

Title of Documentation	Reference Number
<i>MH3 Servo motor Motor Manual</i>	0198441114042 (EN)
	0198441114041 (DE)
<i>SH3 Servo motor Motor Manual</i>	0198441113987 (EN)
	0198441113986 (DE)
<i>Lexium 52 Hardware Guide</i>	EIO0000001347 (EN)
	EIO0000001348 (DE)
<i>Lexium 62 ILD Hardware Guide</i>	EIO0000002443 (EN)
	EIO0000002444 (DE)
<i>Lexium 62 ILM Hardware Guide</i>	EIO0000001351 (EN)
	EIO0000001352 (DE)
<i>Lexium 62 Hardware Guide</i>	EIO0000001349 (EN)
	EIO0000001350 (DE)
<i>SchneiderElectricRobotics Library Guide</i> (only available in the online help)	EIO0000002236 (EN)
<i>RoboticModule Library Guide</i> (only available in the online help)	EIO0000002234 (EN)

Title of Documentation	Reference Number
Cybersecurity Guidelines for EcoStruxure Machine Expert, Modicon and PacDrive Controllers and Associated Equipment, User Guide	EIO0000004242 (EN)
Recommended Cybersecurity Best Practices	CS-Best-Practices-2019-340 (EN)

You can download these technical publications and other technical information from our website at www.se.com/ww/en/download/.

Product Related Information

The equipment described herein must be used in accordance with the application-specific risk analysis that you are to perform along with verification of all applicable standards. Pay attention in conforming to any safety information, different electrical requirements, and normative standards that would apply to your application of the information contained in the present manual and the manuals for associated equipment.

⚠️⚠️ DANGER

ELECTRIC SHOCK, EXPLOSION, OR ARC FLASH

- Disconnect all power from all equipment including connected devices prior to removing any covers or doors, or installing or removing any accessories, hardware, cables, or wires except under the specific conditions specified in the appropriate hardware guide for this equipment.
- Always use a properly rated voltage sensing device to confirm the power is off where and when indicated.
- Operate electrical components only with a connected protective ground (earth) cable.
- Verify the secure connection of the protective ground (earth) cable to all electrical devices to ensure that connection complies with the connection diagram.
- Do not touch the electrical connection points of the components when the module is energized.
- Provide protection against indirect contact.
- Insulate any unused conductors on both ends of the motor cable.

Failure to follow these instructions will result in death or serious injury.

⚠️ WARNING

UNINTENDED EQUIPMENT OPERATION

- Perform a hazard and risk analysis to determine the appropriate safety integrity level, and any other safety requirements, for your specific application based on all the applicable standards.
- Ensure that the hazard and risk analysis is conducted and respected according to EN/ISO 12100 during the design of your machine.

Failure to follow these instructions can result in death, serious injury, or equipment damage.

⚠ WARNING

LOSS OF CONTROL

- The designer of any control scheme must consider the potential failure modes of control paths and, for certain critical control functions, provide a means to achieve a safe state during and after a path failure. Examples of critical control functions are emergency stop and overtravel stop, power outage and restart.
- Separate or redundant control paths must be provided for critical control functions.
- System control paths may include communication links. Consideration must be given to the implications of unanticipated transmission delays or failures of the link.
- Observe all accident prevention regulations and local safety guidelines.¹
- Each implementation of this equipment must be individually and thoroughly tested for proper operation before being placed into service.

Failure to follow these instructions can result in death, serious injury, or equipment damage.

¹ For additional information, refer to NEMA ICS 1.1 (latest edition), “Safety Guidelines for the Application, Installation, and Maintenance of Solid State Control” and to NEMA ICS 7.1 (latest edition), “Safety Standards for Construction and Guide for Selection, Installation and Operation of Adjustable-Speed Drive Systems” or their equivalent governing your particular location.

Terminology Derived from Standards

The technical terms, terminology, symbols and the corresponding descriptions in this manual, or that appear in or on the products themselves, are generally derived from the terms or definitions of international standards.

In the area of functional safety systems, drives and general automation, this may include, but is not limited to, terms such as *safety*, *safety function*, *safe state*, *fault*, *fault reset*, *malfunction*, *failure*, *error*, *error message*, *dangerous*, etc.

Among others, these standards include:

Standard	Description
IEC 61131-2:2007	Programmable controllers, part 2: Equipment requirements and tests.
ISO 13849-1:2015	Safety of machinery: Safety related parts of control systems. General principles for design.
EN 61496-1:2013	Safety of machinery: Electro-sensitive protective equipment. Part 1: General requirements and tests.
ISO 12100:2010	Safety of machinery - General principles for design - Risk assessment and risk reduction
EN 60204-1:2006	Safety of machinery - Electrical equipment of machines - Part 1: General requirements
ISO 14119:2013	Safety of machinery - Interlocking devices associated with guards - Principles for design and selection
ISO 13850:2015	Safety of machinery - Emergency stop - Principles for design
IEC 62061:2015	Safety of machinery - Functional safety of safety-related electrical, electronic, and electronic programmable control systems
IEC 61508-1:2010	Functional safety of electrical/electronic/programmable electronic safety-related systems: General requirements.
IEC 61508-2:2010	Functional safety of electrical/electronic/programmable electronic safety-related systems: Requirements for electrical/electronic/programmable electronic safety-related systems.

Standard	Description
IEC 61508-3:2010	Functional safety of electrical/electronic/programmable electronic safety-related systems: Software requirements.
IEC 61784-3:2016	Industrial communication networks - Profiles - Part 3: Functional safety fieldbuses - General rules and profile definitions.
2006/42/EC	Machinery Directive
2014/30/EU	Electromagnetic Compatibility Directive
2014/35/EU	Low Voltage Directive

In addition, terms used in the present document may tangentially be used as they are derived from other standards such as:

Standard	Description
IEC 60034 series	Rotating electrical machines
IEC 61800 series	Adjustable speed electrical power drive systems
IEC 61158 series	Digital data communications for measurement and control – Fieldbus for use in industrial control systems

Finally, the term *zone of operation* may be used in conjunction with the description of specific hazards, and is defined as it is for a *hazard zone* or *danger zone* in the *Machinery Directive (2006/42/EC)* and *ISO 12100:2010*.

NOTE: The aforementioned standards may or may not apply to the specific products cited in the present documentation. For more information concerning the individual standards applicable to the products described herein, see the characteristics tables for those product references.

Figures

Unless otherwise stated, the different robot types and variants of the Lexium P robots are represented in the figures by the robot type VRKP4 with standard housing.

Dual Dimensions

Dimensions are indicated in metric system and U.S. customary units system. The U.S. dimensions are given in parentheses, for example 8.4 mm (0.33 in).

NOTE: The values in parentheses are rounded and are for reference only.

Hazard Information

What's in This Chapter

Proper Use	12
Qualification of Personnel	14
Residual Risks	14

Proper Use

Overview

This section contains information regarding the operation of the Lexium P robot. Qualified personnel, page 14, working with the robot must read and observe this information.

Installation

The robot is intended to be integrated into a machine or assembled with other components to build up a machine or system. The robot is an open type robot that is intended to be installed into an enclosure to provide access protection.

Provide for Protective Measures

Before installing the robot, provide appropriate protective devices in compliance with local and national standards. Do not commission components without appropriate protective devices. After installation, commissioning, or repair, test the protective devices used.

Other standards are applicable as guideline for a robot integration into the machine such as (non exhaustive list):

- Directive 2006/42/EC on machinery
- Standard ISO 10218-1:2011 Robots and robotic devices - Safety requirements for industrial robots - Part 1: Robots
- Standard ISO 10218-2:2011 Robots and robotic devices - Safety requirements for industrial robots - Part 2: Robot systems and integration
- Standard ISO 13857:2008 Safety of machinery - Safety distances to prevent hazard zones being reached by upper and lower limbs
- Standard ISO 14120:2015 Safety of machinery - Guards - General requirements for the design and construction of fixed and movable guards
- Standard EN 349:2008 Safety of machinery - Minimum gaps to avoid crushing of parts of the human body
- Standard ISO 13855:2010 Safety of machinery - Positioning of safeguards with respect to the approach speeds of parts of the human body
- Standard NFPA 79 Electrical Standard for Industrial Machinery
- Standard UL 1740 Standard for Robots and Robotic Equipment
- Standard UL 2011 Standard for Factory Automation Equipment

Perform a risk evaluation concerning the specific use before operating the robot and take appropriate security measures.

▲ WARNING**UNINTENDED EQUIPMENT OPERATION**

Ensure that a risk assessment is conducted and respected according to EN/ISO 12100 during the design of your machine.

Failure to follow these instructions can result in death, serious injury, or equipment damage.

If circumstances occur that affect the safety or cause changes to the operating behavior of the robot, then immediately shut down the robot and contact your local Schneider Electric service representative.

Use Original Equipment Only

Use only the accessories and mounting parts specified in the documentation and only third-party devices or components that have been expressly approved by Schneider Electric. Only modify the robot in the manner intended and described in this documentation, and other documentation concerning any other associated equipment.

▲ WARNING**UNINTENDED EQUIPMENT OPERATION**

- Only use software and hardware components approved by Schneider Electric for use with this equipment.
- Update your application program every time you change the physical hardware configuration.

Failure to follow these instructions can result in death, serious injury, or equipment damage.

Misuse

The robot is not suitable for the manipulation of living organisms or explosive materials, nor is it suitable for impact movement.

Incompatible Environments

The components must not be used in the following environments:

- Hazardous (explosive) atmospheres
- Mobile, movable, or floating systems
- Life support systems
- Domestic appliances
- Underground
- Highly saline environments (refer to *Technical Data*, page 30 for materials used)
- Environments with increased radioactive radiation

This equipment has been designed to operate outside of any hazardous location. Only install this equipment in zones known to be free of a hazardous atmosphere.

This equipment has been designed to operate outside of any hazardous location. Only install this equipment in zones known to be free of a hazardous atmosphere.

⚠ DANGER

POTENTIAL FOR EXPLOSION

Install and use this equipment in non-hazardous locations only.

Failure to follow these instructions will result in death or serious injury.

Installation and Operating Conditions

Only use the components in accordance with the installation and operating conditions described in this documentation. The operating conditions at the installation location must be inspected and maintained in accordance with the required technical data (performance data and ambient conditions). Commissioning is prohibited until the usable machine or system in which the robot is installed is in accordance to the applicable local regulations and standards.

Qualification of Personnel

Target Audience for This Manual

This documentation is intended for users having the following knowledge:

- Advanced knowledge in mechanical engineering
- Advanced knowledge in electrical engineering
- Knowledge of the robot control system, its installation and operation, as well as the construction of the machine/application in which it is intended

Qualified Person

Aside from skills and knowledge, qualified personnel must be able to detect possible hazards that may arise from parametrization, changing parameter values and generally from mechanical, electrical, or electronic equipment. The qualified personnel must be familiar with the standards, provisions, and regulations for the prevention of industrial accidents, which they must observe when working on the drive system.

Residual Risks

Overview

Risks arising from the robot have been reduced. However a residual risk remains since the robot is moved and operated with electrical voltage and electrical currents.

If activities involve residual risks, a safety message is made at the appropriate points. This includes potential hazards that may arise, their possible consequences, and describes preventive measures to avoid the hazards.

Electrical Parts

DANGER

ELECTRIC SHOCK, EXPLOSION, OR ARC FLASH

- Disconnect all power from all equipment including connected devices prior to removing any covers or doors, or installing or removing any accessories, hardware, cables, or wires except under the specific conditions specified in the appropriate hardware guide for this equipment.
- Always use a properly rated voltage sensing device to confirm the power is off where and when indicated.
- Operate electrical components only with a connected protective ground (earth) cable.
- Verify the secure connection of the protective ground (earth) cable to all electrical devices to ensure that connection complies with the connection diagram.
- Do not touch the electrical connection points of the components when the module is energized.
- Provide protection against indirect contact.
- Insulate any unused conductors on both ends of the motor cable.

Failure to follow these instructions will result in death or serious injury.

Emergency Stop

The robot mechanics, apart from the motor, are not supplied with external brakes nor an emergency stop switch to engage any external brakes.

WARNING

ENTRAPMENT BY ROBOT MECHANICS

- Provide means for ensuring that the motors can be put into a voltage-free state with any internal holding brake or external service brake released.
- Make available those means to allow one person to manually move the robot within reach of the zone of operation.

Failure to follow these instructions can result in death, serious injury, or equipment damage.

The opening of the motor holding brakes may cause the robot to sag.

WARNING

SAGGING OF THE ROBOT

Ensure that the release of the motor brakes poses no subsequent risks in the zone of operation.

Failure to follow these instructions can result in death, serious injury, or equipment damage.

NOTE: Provide separation devices for all infeed energies. It must be possible to secure the separation devices in de-energized position, for example, by locking.

Assembly and Handling

⚠ WARNING

CRUSHING, SHEARING, CUTTING AND HITTING DURING HANDLING

- Observe the general construction and safety regulations for handling and assembly.
- Use appropriate mounting and transport equipment and use appropriate tools.
- Prevent clamping and crushing by taking appropriate precautions.
- Cover edges and angles to protect against cutting damage.
- Wear suitable protective clothing (for example, protective goggles, protective boots, protective gloves).

Failure to follow these instructions can result in death, serious injury, or equipment damage.

Robot Motion

Parts of the mechanics can move at high speeds. In such cases, the payload weight, additionally installed gripper, and shifts in the center of gravity of the moving parts contribute to the total energy of the forces generated.

Motion sequences can occur when operating with robot mechanics, which allow operational staff to make misjudgments. For safety considerations (according to EN ISO 13849-1), consider the controller and the brakes as non-safety-related elements. Ensure that necessary protective measures are implemented.

The safety standards and directives for the respective country where the equipment is in use define which protective measures are appropriate. Additionally, the system engineer who is responsible for the integration of the robot mechanics must evaluate which measures have to be taken.

NOTE: The configuration of the robot mechanics, the Tool Center Point (TCP) velocity, as well as the additional payload have an effect on the total energy, which can potentially be a source of damage and injury.

⚠ WARNING

CRUSHING, SHEARING, CUTTING AND IMPACT INJURY

- The robot must be operated only within an enclosure.
- Open or enter the enclosure for cleaning and maintenance purposes only.
- Design the enclosure to withstand an impact from the robot and to resist ejected parts from escaping the zone of operation.
- Design the enclosure to safely deactivate the robot as soon as a person enters the zone of operation of the robot.
- All barriers, protective doors, contact mats, light barriers, and other protective equipment, must be configured correctly and enabled whenever the robot mechanics are under power.
- Define the clearance distance to the zone of operation of the robot so the operational staff do not have access to, nor can be enclosed in, the robot mechanics zone of operation.
- Design the enclosure to account for the maximum possible travel paths of the robot; that is, the maximum path until the hardware safety system limits as well as the additional run-on paths, in case of a power interruption.

Failure to follow these instructions can result in death, serious injury, or equipment damage.

For detailed information about travel path and power loss, refer to *Run-on Motions of the Robot for Risk Analysis*, page 94.

Hot Surfaces

The metal surfaces of the robot may exceed 70 °C (158 °F) during operation.
The following figure presents the hot surface labels on the robot.

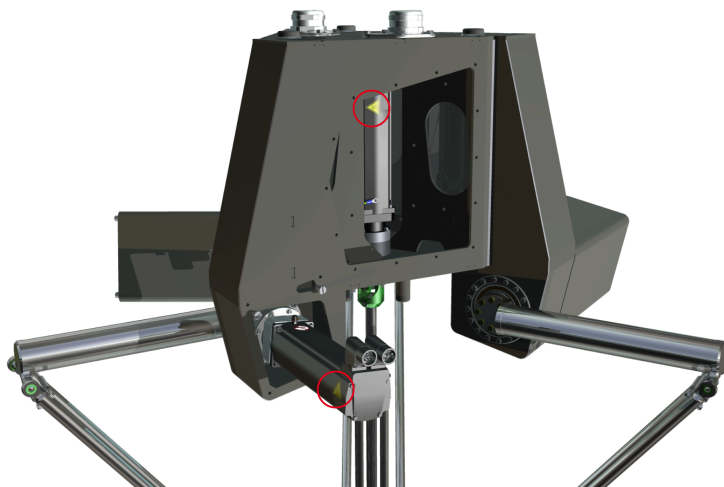

▲ WARNING

HOT SURFACES

- Avoid unprotected contact with hot surfaces.
- Do not allow flammable or heat-sensitive parts in the immediate vicinity of hot surfaces.
- Verify that the heat dissipation is sufficient by performing a test run under maximum load conditions.

Failure to follow these instructions can result in death, serious injury, or equipment damage.

Hazardous Movements

There can be different sources of hazardous movements:

- No or incorrect calibration of the drive
- Wiring or cabling errors
- Errors in the application program
- Component errors
- Error in the measured value and signal transmitter

NOTE: Provide for personal safety by primary equipment monitoring or measures. Do not rely only on the internal monitoring of the drive components. Adapt the monitoring or other arrangements and measures to the specific conditions of the installation in accordance with a hazard and risk analysis.

⚠ DANGER**UNAVAILABLE OR INADEQUATE PROTECTION DEVICE(S)**

- Prevent entry to a zone of operation with, for example, protective fencing, mesh guards, protective coverings, or light barriers.
- Dimension the protective devices properly and do not remove or modify them.
- Do not make any modifications that can degrade, incapacitate, or in any way invalidate protection devices.
- Bring the drives and the motors they control to a stop before accessing the drives or entering the zone of operation.
- Protect existing workstations and operating terminals against unauthorized operation.
- Position emergency stop switches so that they are easily accessible and can be reached quickly.
- Validate the functionality of emergency stop equipment before start-up and during maintenance periods.
- Prevent unintentional start-up by disconnecting the power connection of the drives using the emergency stop circuit or using an appropriate lock-out tag-out sequence.
- Validate the system and installation before the initial start-up.
- Avoid operating high-frequency, remote control, and radio devices close to the system electronics and their feed lines.
- Perform, if necessary, a special electromagnetic compatibility (EMC) verification of the system.

Failure to follow these instructions will result in death or serious injury.

Drive systems may perform unanticipated movements because of incorrect wiring, incorrect settings, incorrect data, or other errors.

⚠ WARNING**UNINTENDED MOVEMENT OR MACHINE OPERATION**

- Carefully install the wiring in accordance with EMC standards.
- Do not operate the robot with undetermined settings and data.
- Perform comprehensive commissioning tests that include verification of configuration settings and data that determine position and movement.

Failure to follow these instructions can result in death, serious injury, or equipment damage.

Noise Protection

The noise level of the mechanics depends on the basic cycle and the payload, as well as on further application-specific accessory parts. Be aware of the fact that noise emissions multiply when several mechanics are in use at the same time. If noise emissions reach a value of more than 70 dBA, wear hearing protection.

⚠ CAUTION**NOISE EMISSIONS OF THE ROBOT MECHANICS**

- Wear hearing protection in accordance with the locally applicable regulations.
- Attach a sign on the robot mechanics if the noise emissions reach an excessive value.

Failure to follow these instructions can result in injury or equipment damage.

NOTE: Attach the following symbol where it can easily be seen on the robot mechanics.



Emissions

Some small amounts of lubricant emissions are to be expected over time. However, excessive lubricant emissions on or at the gearbox may be an indication of a damaged robot.

NOTICE

INOPERABLE EQUIPMENT INDICATED BY GEARBOX LUBRICANT EMISSIONS

- Verify the mechanics before, during, and after use.
- Shut down the mechanics immediately if lubricant emissions appear on the robot mechanics.

Failure to follow these instructions can result in equipment damage.

NOTE: To prevent any lubricant emissions, see chapter *Gearbox Leakage Protection*, page 146.

Hanging Loads

The robot is capable of suspending heavy loads.

▲ WARNING

FALLING LOADS

Do not stand under hanging loads.

Failure to follow these instructions can result in death, serious injury, or equipment damage.

Attachments or Modifications

If different customer end products are transported by the robot mechanics, then the product pickup must be modified accordingly. For this reason, you can mount different product pickups (gripper mounting) to the flange. In doing so, ensure that the articulation movement is not restricted and/or that no motion errors can result from the modifications. Attachments and rebuilds must not influence the operation of the protective devices in any way and all EMERGENCY STOP buttons must be accessible and operational at all times.

⚠ WARNING**UNINTENDED MACHINE OPERATION**

- Do not drill into or modify the articulated arms.
- Do not modify the cable set.
- Do not modify the housing.
- Do not modify the components of movable mechanics.

Failure to follow these instructions can result in death, serious injury, or equipment damage.

The robot housing is part of the heat dissipation concept of the system. For this reason, the housing must be kept clean and free of any coating or paint.

NOTICE**INOPERABLE EQUIPMENT**

- Keep the housing clean.
- Do not apply coating or painting to the housing nor anything that would affect the heat dissipation properties of the housing surface.

Failure to follow these instructions can result in equipment damage.

Options for Moving the Robot Without Drive Energy

The robot mechanics are not equipped with an enclosure (see UL 1740).

NOTE: Take appropriate security measures concerning the specific use before operating the robot.

⚠ WARNING**SAGGING OF THE ROBOT**

Ensure that the release of the motor brakes poses no subsequent risks in the zone of operation.

Failure to follow these instructions can result in death, serious injury, or equipment damage.

If you have to move the complete robot manually, perform the following steps:

Step	Action
1	Put the robot into a torque-free state.
2	Manually hold the robot in position.
3	Release the motor brakes. NOTE: The function for releasing the brakes as well as for torque-free switching of the motors is not controlled by the equipment delivered with the product reference, but must be addressed by the application.
4	Manually move the robot. NOTE: A greater force could be necessary because the motor and the gearbox may pose resistance to movement.
5	Engage the brakes.

If you have to move the upper arms manually, proceed as follows:

Step	Action
1	Pull the lower arms off the ball pins.
2	In case, the lower arms cannot be pulled off the ball pins, proceed as follows: Grip in the middle of the lower arms and apply pressure to bend the lower arms to release the ball pins.

If an object is trapped by the upper arm of the robot and the equipment is without power, proceed as follows:

Step	Action
1	Pull the lower arm off the ball pins.
2	Perform one of the following actions: <ul style="list-style-type: none">Manually move the upper arm against the closed brake. NOTE: This requires a high degree of force.Remove the bolts on the upper arm and then remove the upper arm.

System Overview

What's in This Chapter

System Architecture	22
Product Overview	23
Type Code	26
Type Plate	28

System Architecture

Overview

The control system consists of several components, depending on its application. The following graphic presents an example of a PacDrive 3 system.

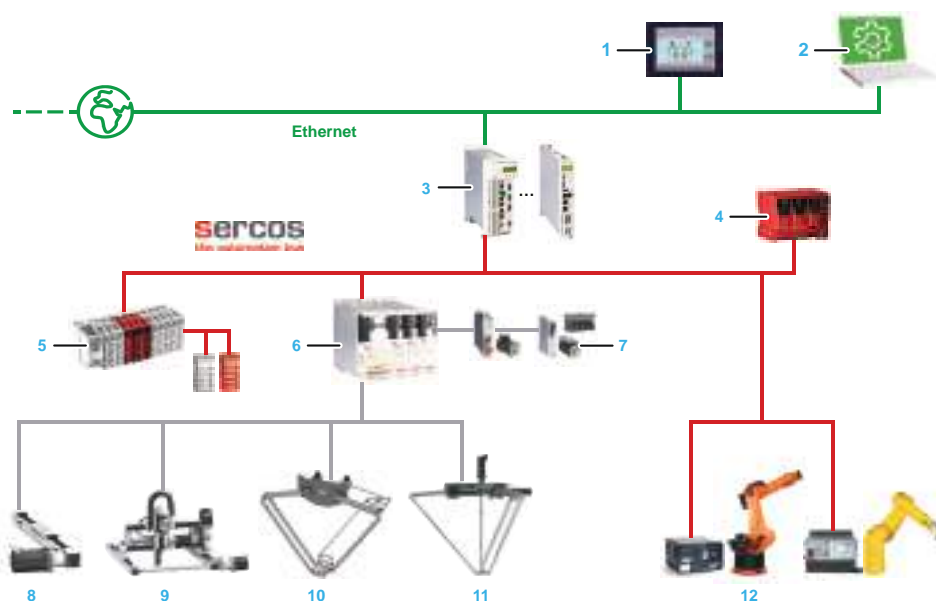

- | | |
|------------------------------|---|
| 1 Harmony SCU HMI Controller | 7 Motors |
| 2 EcoStruxure Machine Expert | 8 Single Axes (CAR, CAS, EAC, PAD, PAS, TAS) |
| 3 Motion Controller | 9 Multi-Axis Systems (MAXH, MAXS, MAXP, MAXR) |
| 4 Safety Controller | 10 Delta-2 Robots (Lexium T) |
| 5 I/O | 11 Delta-3 Robots (Lexium P) |
| 6 Drives | 12 Articulated Robots |

NOTE: To help keep your Schneider Electric products secure and protected, refer to the *Cybersecurity Best Practices* and *Cybersecurity Guidelines* provided on the Schneider Electric website. See *Related Documents*, page 8.

Product Overview

System Setup

The following figure presents an example of a system setup for one Lexium P robot with SH3 motors. At a minimum, this is the equipment required to achieve performances described in this guide.

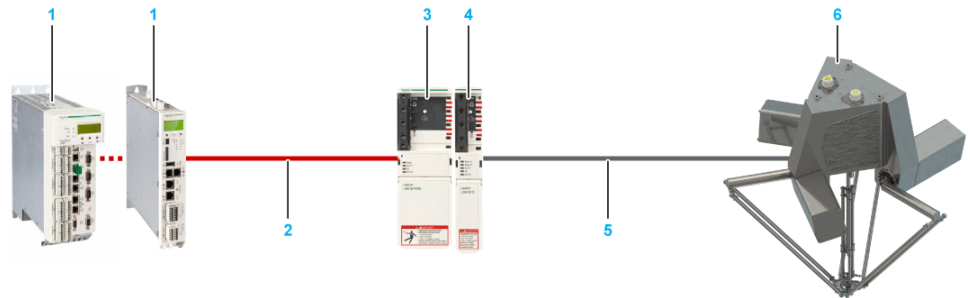

Number	Device name	Quantity	Device type	Comment
1	Controller	1	LMC•00C...LMC•01C	Logic Motion Controller
2	Sercos cable	3	VW3E5001R	Sercos cable; the cable length depends on the distance between controller and cabinet.
3	Power supply	1	LXM62PD84A11000	Lexium 62 Power Supply ⁽¹⁾
4	Double drive	2	Double drive: LXM62DD15•21000 ⁽²⁾	Lexium 62 Drive Module
	Single drive	3 or 4 ⁽³⁾	Single drive: LXM62DD15•21000 ⁽²⁾	Lexium 62 Drive Module ⁽¹⁾
5	Motor cable for connection of drive and motor	3 or 4 ⁽³⁾	VW3E1143R•••	PacDrive 3 motor cable; the cable length depends on the distance between cabinet and robot.
	Feedback cable for connection of drive and motor	3 or 4 ⁽³⁾	VW3E2094R•••	
6	Lexium P robot with SH3 motors	1	⁽⁴⁾	

(1) Alternatively, use the Lexium LXM52, Stand-Alone Servo Drive. Quantity: 3 or 4. Device type: LXM52DD18C.

(2) The specific variant of the drive depends on the safety requirements.

(3) The quantity depends on whether the robot has a rotational axis or not.

(4) The device type depends on the robot reference and its characteristics. For further information, refer to *Type Code*, page 26.

The following figure presents an example of a system setup for one Lexium P robot with SH3 motors and Lexium 62 ILD Detached Drive. At a minimum, this is the equipment required to achieve performances described in this guide.

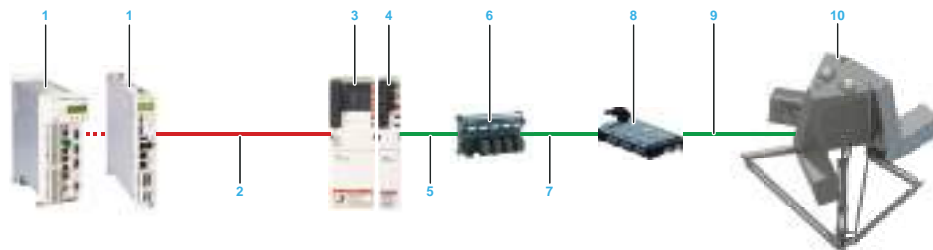

Number	Device name	Quantity	Device type	Comment
1	Controller	1	LMC•00C...LMC•01C	Logic Motion Controller
2	Sercos cable	3	VW3E5001R	Sercos cable; the cable length depends on the distance between controller and cabinet.
3	Power supply	1	LXM62PD84A11000	Lexium 62 Power Supply
4	Connection module	1	ILM62CMD20A000	Lexium 62 Connection Module
5	Cable for connection of connection module and distribution box	1	VW3E1•••R•••	Hybrid cable; the cable length depends on the distance between the cabinet and the robot. Various connectors are available.
6	Distribution box	1	ILM62DB4A000	Lexium 62 Distribution Box; already included in the housing of Lexium P robots VRKP4•••WD / VRKP4•••NO / VRKP4•••CW (not included in other Lexium P robots).
7	Cable for connection of distribution box and Lexium 62 ILD Detached Drive	3 or 4 ⁽¹⁾	VW3E1•••R•••	Hybrid cable; the cable length depends on the distance between the distribution box and the Lexium 62 ILD Detached Drive. Various connectors are available.
8	Lexium 62 ILD Detached Drive	1	Triple Drive: ILM62DDD24D1000 Additionally for robots with a rotational axis: Single Drive: ILM62DDD24C1000	Lexium 62 ILD Detached Drive
9	Motor cable for connection of Lexium 62 ILD Detached Drive and motor	3 or 4 ⁽¹⁾	FCE310•••A200	Motor cable and feedback cable; the cable length depends on the distance between the Lexium 62 ILD Detached Drive and the robot
	Feedback cable for connection of Lexium 62 ILD Detached Drive and motor	3 or 4 ⁽¹⁾	FCE311•••A200	
10	Lexium P robot with SH3 motors	1	⁽²⁾	

(1) The quantity depends on whether the robot has a rotational axis or not.

(2) The device type depends on the robot reference and its characteristics. For further information refer to *Type Code*, page 26.

The following figure presents an example of a system setup for one Lexium P robot with ILM motors. At a minimum, this is the equipment required to achieve performances described in this guide.

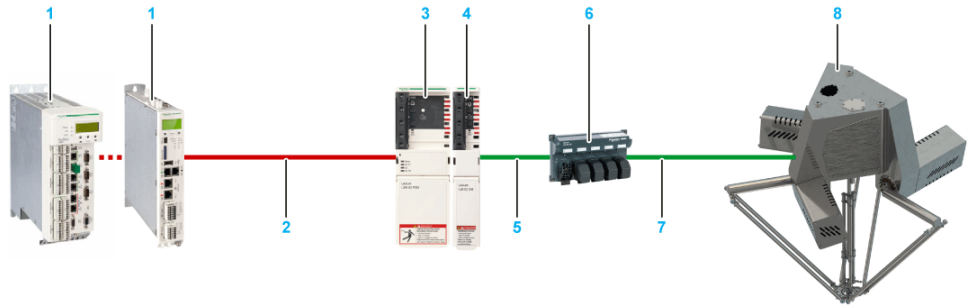

Number	Device name	Quantity	Device type	Comment
1	Controller	1	LMC•00C...LMC•01C	Logic Motion Controller
2	Sercos cable	3	VW3E5001R	Sercos cable; the cable length depends on the distance between controller and cabinet.
3	Power supply	1	LXM62PD84A11000	Lexium 62 Power Supply
4	Connection module	1	ILM62CMD20A000	Lexium 62 Connection Module
5	Cable for connection of connection module and distribution box	1	VW3E1•••R•••	Hybrid cable; the cable length depends on the distance between the cabinet and the robot. Various connectors are available.
6	Distribution box	1	ILM62DB4A000	Lexium 62 Distribution Box; already included in the housing of Lexium P robots VRKP4•••WD / VRKP4•••NO / VRKP4•••CW (not included in other Lexium P robots).
7	Cable for connection of distribution box and motor	3 or 4 ⁽¹⁾	VW3E1•••R•••	Hybrid cable; the cable length depends on the distance between the cabinet and the robot. Various connectors are available.
8	Lexium P robot with ILM motors	1	⁽²⁾	

(1) The quantity depends on whether the robot has a rotational axis or not.

(2) The device type depends on the robot reference and its characteristics. For further information refer to *Type Code*, page 26.

System Performance

System performance for a robotic application (including enough performance overhead for additional application components):

PacDrive LMC (Logic Motion Controller)	Sercos cycle time 1 ms		Sercos cycle time 2 ms	
	Simple control ⁽¹⁾	Control with velocity control ⁽¹⁾	Simple control ⁽¹⁾	Control with velocity control ⁽¹⁾
PacDrive LMC101	1	–	1	1
PacDrive LMC106	1	–	1	1
PacDrive LMC201	2	–	2	1
PacDrive LMC212	2	–	4	1
PacDrive LMC216	2	–	4	1
PacDrive LMC400	3	1	4	2
PacDrive LMC402	4	4	4	4

PacDrive LMC (Logic Motion Controller)	Sercos cycle time 1 ms		Sercos cycle time 2 ms	
	Simple control ⁽¹⁾	Control with velocity control ⁽¹⁾	Simple control ⁽¹⁾	Control with velocity control ⁽¹⁾
PacDrive LMC600	6	2	12	4
PacDrive LMC802	11	4	22	8

(1) Number of controllable robots (four axes per robot)

Components Overview

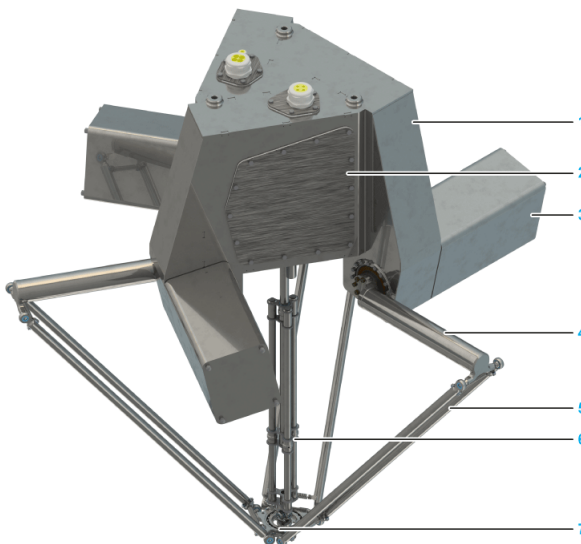

1	Housing
2	Maintenance cover
3	Motor cover (covering motor and gearbox)
4	Upper arm

5	Lower arm
6	Telescopic axis
7	Parallel plate

Characteristics of the Lexium P Robot

The robot provides the following features:

- Stainless steel Delta 3 robot equipped by an automation platform
- Few references covering large performance
- Applicable in cleanrooms as well as in harsh environments
- Preassembled and ready to connect
- No calibration at customer site and automatic recalibration without tools
- Fast replacement of replacement equipment
- Available with or without a rotational axis (telescopic axis, ball bearing at the parallel plate, additional motor and gearbox)

Type Code

Example of a type code for the Lexium P robot:

Character	1	2	3	4	5	6	7	8	9	10	11	12	13	14	15
Example	V	R	K	P	4	S	0	R	N	O	0	0	0	0	0

Description of the type code structure with reference to the example stated above:

Character	Example	Item	Meaning
1...3	VRK	Robot kinematics	–
4...5	P4	Robot/product type	P0 = 3-4 axis Delta 400 mm (15.8 in) P1 = 3-4 axis Delta 600 mm (23.6 in) P2 = 3-4 axis Delta 800 mm (31.5 in) P4 = 3-4 axis Delta 1200 mm (47 in) P5 = 3-4 axis Delta 1400 mm (55 in) P6 = 3-4 axis Delta 1600 mm (63 in) PX = parts for Lexium P robots. For example: replacement equipment.
6...7	S0	Subtype	S0 = SH3 motor (P0, P1, P2, P4, P5, P6) ⁽¹⁾ I0 = iSH motors (P2, P4) ⁽²⁾ L0 = ILM motors (P2, P4, P5, P6) WM = without motors (P2, P4, P5, P6) YY = replacement equipment set
8	R	Option	R = rotational axis installed F = fixed, no rotational axis installed C = customized version Y = replacement equipment (replacement equipment for customized editions = C) M = module installed
9...10	NO	Variant	WD = standard housing, washdown (P2, P4) NF = flat housing, not washdown (P4) NO = standard housing, not washdown (P4) WF = flat housing, washdown (P0, P1, P4, P5, P6) CW = cleanroom, washdown (P4) NC = normal, Compact (P0, P1, P2, P4, P5, P6) 01 = customized version 01 YY = replacement equipment
11...12	00	Revision	00 = S00 (P0, P1, P2, P4, P5, P6) 02 = S02 (flat P0, P1, P4, P5, P6)
13	0	Working space	0 = without options E = extended working space (P0, P1, P6) • = replacement equipment
14...15	00	Miscellaneous	00 = without options 45 = motorized module (Rotational Module B) •• = replacement equipment
<p>(1) The rotational axis of VRKP0 / VRKP1 / VRKP4••WF / VRKP5••WF / VRKP6••WF is equipped with a MH3 motor. For further information, refer to <i>Mechanical and Electrical Data</i>, page 31.</p> <p>(2) This subtype is obsolete. Replacement equipment is available for this subtype, page 244.</p>			

If you have questions concerning the type code, contact your local Schneider Electric service representative.

Type Plate

Position of the Type Plate

Representation for VRKP••••WD / VRKP••••NO / VRKP••••CW / VRKP••••WF

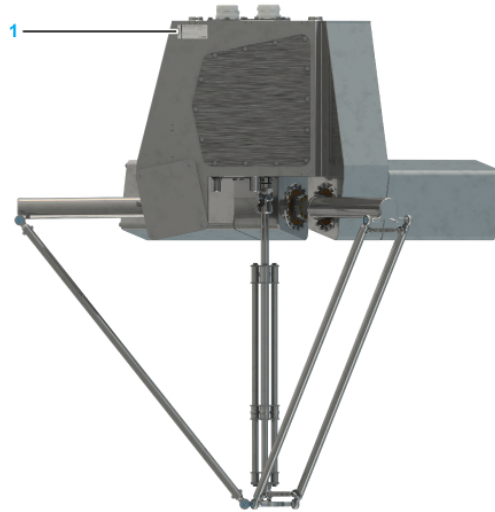

1 Type plate

Representation for VRKP••••NC



1 Type plate

Description of the Type Plate

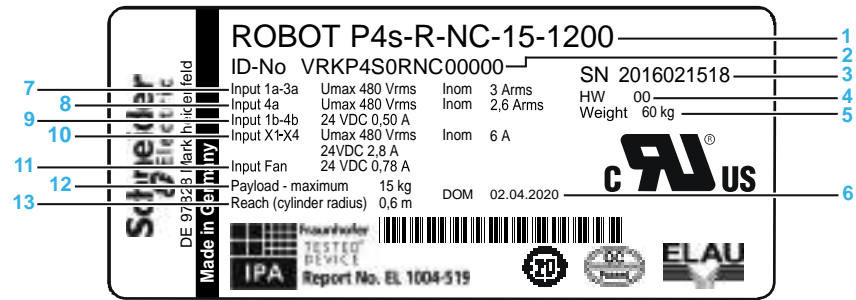

1	Device name
2	Type code*
3	Serial number
4	Hardware code
5	Weight of the robot
6	Date of manufacture
7	Voltage and current of the main axis SH3-motors

8	Voltage and current of the rotational axis SH3-motor
9	Voltage and current of the SH3-motor brakes
10	Voltage and current of all ILM-motors and brakes
11	Voltage and current of the fans
12	Maximum Load
13	Radius of the working space

* For detailed information about the meaning of the particular digits, refer to *Type Code*, page 26.

Technical Data

What's in This Chapter

Ambient Conditions	30
Mechanical and Electrical Data of Lexium P Robots	31
Dimensional Drawings	59
Electrical Connections	79
Performance Data	81
Design of the Robot Frame	91
Run-On Motions of the Robot for Risk Analysis	94
Technical Data of the Motor and the Gearbox	102

Ambient Conditions

Ambient Conditions

Procedure	Parameter	Unit	Value
Operation ⁽¹⁾	Classes 3K3, 3Z12, 3Z2, 3B2, 3C1, 3M7 (according to IEC/EN 60721-3-3)		
	Ambient temperature	°C (°F)	+5...+40 (+41...+104) ⁽²⁾
	Condensation	–	prohibited
	Formation of ice	–	prohibited
	Relative humidity	%	5...85
Transport	Set of class combinations IE21 (according to IEC/EN 60721-3-2) ⁽³⁾		
	Ambient temperature	°C (°F)	-20...+70 (-4...+158)
	Condensation	–	prohibited
	Precipitation	–	prohibited
	Formation of ice	–	prohibited
	Other liquid	–	prohibited
	Wetness	–	prohibited
	Relative humidity	%	< 75
Long-term storage in transport packaging	Class 1K3 (according to IEC/EN 60721-3-1) ⁽⁴⁾		
	Ambient temperature	°C (°F)	0...+40 °C (+32...+104 °F)
	Condensation	–	prohibited
	Precipitation	–	prohibited
	Formation of ice	–	prohibited
	Other liquid	–	prohibited
	Relative humidity	%	5...95
	Maximum storage period	years	2
<p>(1) Installation altitude without power reduction < 1000 m (3281 ft).</p> <p>(2) Power reduction for Lexium P Compact versions with ILM motors at ambient temperatures exceeding +25 °C (+77 °F). Power reduction depends on the application. If some severities of parameters deviate from the specified ambient conditions, contact your local Schneider Electric service representative for more information.</p> <p>(3) All parameters conform to the specified class except for the ambient temperature and the relative humidity which is limited by other components of the system.</p> <p>(4) All parameters conform to the specified class except for the ambient temperature which is limited by other components of the system.</p>			

For further information about storage conditions, refer to *Transport and Storage*, page 104.

Mechanical and Electrical Data of Lexium P Robots

Robot VRKP0...WF

Mechanical and Electrical Data of VRKP0...WF

Category	Parameter	Unit	VRKP0S0FWF
			VRKP0S0RWF
General data	Rated load	kg (lb)	1.5 (3.3)
	Maximum load ⁽¹⁾	kg (lb)	10 (22)
	Maximum velocity	m/s (ft/s)	6 (20)
	Maximum acceleration ⁽²⁾ for 1 kg (2.2 lb)	m/s ² (ft/s ²)	125 (410)
	Maximum acceleration ⁽²⁾ for 1.5 kg (3.3 lb)	m/s ² (ft/s ²)	120 (394)
	Maximum acceleration ⁽²⁾ for > 1.5 kg (3.3 lb)	m/s ² (ft/s ²)	⁽¹⁾
	Number of axes	–	3 (fixed option) / 4 (rotational axis installed)
	Position repeatability (ISO 9283)	–	Position: 0.05 (0.0020)
		–	Angle: +/-0.3° ⁽³⁾
Maximum torque of the rotational axis ⁽⁴⁾	Nm (lbf-in)	4.5 (40) ⁽⁵⁾	
Electrical data	Mains voltage - 3-phase	Vac	480 ⁽⁶⁾
	Control voltage (with brake)	Vdc	+24 (-10...+6%)
	Fan voltage	Vdc	+24 (-10...+6%)
	Motor main axes	–	SH30553P02F2000
	Motor rotational axis	–	MH30701P02F2200
	Power consumption for a typical pick & place cycle with 1.5 kg (3.3 lb)	kW (hp)	0.22 (0.295)
Mechanical data	Installation type	–	Ceiling installation
	Protection class for moving parts	–	IP69k
	Basic protection class	–	IP65
	Housing type	–	Compact
Working space	Height x diameter	mm (in)	100 x 400 (3.9 x 15.7) 120 x 300 (4.7 x 11.8)
		–	Unlimited
Weight	–	kg (lb)	approximately 60 (132)
Noise level	–	dB(A)	< 70

Category	Parameter	Unit	VRKP0S0FWF VRKP0S0RWF
Material	External casing	–	Stainless steel 1.4301 aluminum, POM-C, FPM, TPE, PE, PEEK
<p>(1) Loads above the maximum load are possible with restrictions. If required, contact your local Schneider Electric service representative.</p> <p>(2) For a load mounted centrally underneath the flange and a distance of maximum 100 mm (3.9 in) between flange and mass center of gravity.</p> <p>(3) $\pm 0.1^\circ$ is possible with optional equipment. For further information, refer to <i>Rotational Module</i>, page 157, <i>Tilting Module</i>, page 165, <i>Double Rotational Module</i>, page 173 and <i>Rotational Tilting Module</i>, page 184.</p> <p>(4) When designing the gripper, be aware of any appearance of mass moments of inertia as well as friction, which could lead to exceeding the maximum torque and consequential damage.</p> <p>(5) Maximum torque of the rotational axis with the optional Telescopic Axis Double is 3 Nm (31 lbf-in). For further information, refer to <i>Mounting the Telescopic Axis Double</i>, page 155.</p> <p>(6) For further information, refer to <i>Lexium 52 Hardware Guide</i> or <i>Lexium 62 Hardware Guide</i>.</p>			

Robot VRKP0...NC

Mechanical and Electrical Data of VRKP0...NC

Category	Parameter	Unit	VRKP0S0FNC VRKP0S0RNC	
General data	Rated load	kg (lb)	1.5 (3.3)	
	Maximum load ⁽¹⁾	kg (lb)	10 (22)	
	Maximum velocity	m/s (ft/s)	6 (20)	
	Maximum acceleration ⁽²⁾ for 1 kg (2.2 lb)	m/s ² (ft/s ²)	125 (410)	
	Maximum acceleration ⁽²⁾ for 1.5 kg (3.3 lb)	m/s ² (ft/s ²)	120 (394)	
	Maximum acceleration ⁽²⁾ for > 1.5 kg (3.3 lb)	m/s ² (ft/s ²)	⁽¹⁾	
	Number of axes	–	3 (fixed option) / 4 (rotational axis installed)	
	Position repeatability (ISO 9283)		mm (in)	Position: 0.05 (0.0020)
			–	Angle: $\pm 0.3^\circ$ ⁽³⁾
Maximum torque of the rotational axis ⁽⁴⁾	Nm (lbf-in)		4.5 (40) ⁽⁵⁾	
Electrical data	Mains voltage - 3-phase	Vac	480 ⁽⁶⁾	
	Control voltage (with brake)	Vdc	+24 (-10...+6%)	
	Motor main axes	–	SH30553P02F2000	
	Motor rotational axis	–	MH30701P02F2200	
	Power consumption for a typical pick & place cycle with 1.5 kg (3.3 lb)	kW (hp)		0.22 (0.295)
Mechanical data	Installation type	–	Ceiling installation	
	Protection class for moving parts	–	IP69k	
	Basic protection class	–	IP65	
	Housing type	–	Compact	

Category	Parameter	Unit	VRKP0S0FNC
			VRKP0S0RNC
Working space	Height x diameter	mm (in)	100 x 400 (3.9 x 15.7) 120 x 300 (4.7 x 11.8)
	Rotation	–	Unlimited
Weight	–	kg (lb)	approximately 27.6 (60.85)
Noise level	–	dB(A)	< 70
Material	External casing	–	Stainless steel 1.4301 aluminum, POM-C, FPM, TPE, PE, PEEK
<p>(1) Loads above the maximum load are possible with restrictions. If required, contact your local Schneider Electric service representative.</p> <p>(2) For a load mounted centrally underneath the flange and a distance of maximum 100 mm (3.9 in) between flange and mass center of gravity.</p> <p>(3) +/-0.1° is possible with optional equipment. For further information, refer to <i>Rotational Module</i>, page 157, <i>Tilting Module</i>, page 165, <i>Double Rotational Module</i>, page 173 and <i>Rotational Tilting Module</i>, page 184.</p> <p>(4) When designing the gripper, be aware of any appearance of mass moments of inertia as well as friction, which could lead to exceeding the maximum torque and consequential damage.</p> <p>(5) Maximum torque of the rotational axis with the optional Telescopic Axis Double is 3 Nm (31 lbf-in). For further information, refer to <i>Mounting the Telescopic Axis Double</i>, page 155.</p> <p>(6) For further information, refer to <i>Lexium 52 Hardware Guide</i> or <i>Lexium 62 Hardware Guide</i>.</p>			

Robot VRKP0...WF..E00

Mechanical and Electrical Data of VRKP0...WF..E00

Category	Parameter	Unit	VRKP0S0FWF..E00 VRKP0S0RWF..E00	
General data	Rated load	kg (lb)	1.5 (3.3)	
	Maximum load ⁽¹⁾	kg (lb)	10 (22)	
	Maximum velocity	m/s (ft/s)	6 (20)	
	Maximum acceleration ⁽²⁾ for 1 kg (2.2 lb)	m/s ² (ft/s ²)	125 (410)	
	Maximum acceleration ⁽²⁾ for 1.5 kg (3.3 lb)	m/s ² (ft/s ²)	120 (394)	
	Maximum acceleration ⁽²⁾ for > 1.5 kg (3.3 lb)	m/s ² (ft/s ²)	⁽¹⁾	
	Number of axes	–	3 (fixed option) / 4 (rotational axis installed)	
	Position repeatability (ISO 9283)	mm (in)		Position: 0.05 (0.0020)
		–		Angle: +/-0.3° ⁽³⁾
Maximum torque of the rotational axis ⁽⁴⁾	Nm (lbf-in)		4.5 (40) ⁽⁵⁾	
Electrical data	Mains voltage - 3-phase	Vac	480 ⁽⁶⁾	
	Control voltage (with brake)	Vdc	+24 (-10...+6%)	
	Fan voltage	Vdc	+24 (-10...+6%)	
	Motor main axes	–	SH30553P02F2000	
	Motor rotational axis	–	MH30701P02F2200	
	Power consumption for a typical pick & place cycle with 1.5 kg (3.3 lb)	kW (hp)		0.22 (0.295)
Mechanical data	Installation type	–	Ceiling installation	
	Protection class for moving parts	–	IP69k	
	Basic protection class	–	IP65	
	Housing type	–	Compact	
Working space	Height x diameter	mm (in)	160 x 400 (6.3 x 15.7) 180 x 292 (7.1 x 11.5)	
		–	Unlimited	
Weight	–	kg (lb)	approximately 60.2 (133)	
Noise level	–	dB(A)	< 70	

Category	Parameter	Unit	VRKP0S0FWF**E00 VRKP0S0RWF**E00
Material	External casing	–	Stainless steel 1.4301 aluminum, POM-C, FPM, TPE, PE, PEEK
<p>(1) Loads above the maximum load are possible with restrictions. If required, contact your local Schneider Electric service representative.</p> <p>(2) For a load mounted centrally underneath the flange and a distance of maximum 100 mm (3.9 in) between flange and mass center of gravity.</p> <p>(3) +/-0.1° is possible with optional equipment. For further information, refer to <i>Rotational Module</i>, page 157, <i>Tilting Module</i>, page 165, <i>Double Rotational Module</i>, page 173 and <i>Rotational Tilting Module</i>, page 184.</p> <p>(4) When designing the gripper, be aware of any appearance of mass moments of inertia as well as friction, which could lead to exceeding the maximum torque and consequential damage.</p> <p>(5) Maximum torque of the rotational axis with the optional Telescopic Axis Double is 3 Nm (31 lbf-in). For further information, refer to <i>Mounting the Telescopic Axis Double</i>, page 155.</p> <p>(6) For further information, refer to <i>Lexium 52 Hardware Guide</i> or <i>Lexium 62 Hardware Guide</i>.</p>			

Robot VRKP0***NC**E00

Mechanical and Electrical Data of VRKP0***NC**E00

Category	Parameter	Unit	VRKP0S0FNC00E00 VRKP0S0RNC00E00	
General data	Rated load	kg (lb)	1.5 (3.3)	
	Maximum load ⁽¹⁾	kg (lb)	10 (22)	
	Maximum velocity	m/s (ft/s)	6 (20)	
	Maximum acceleration ⁽²⁾ for 1 kg (2.2 lb)	m/s ² (ft/s ²)	125 (410)	
	Maximum acceleration ⁽²⁾ for 1.5 kg (3.3 lb)	m/s ² (ft/s ²)	120 (394)	
	Maximum acceleration ⁽²⁾ for > 1.5 kg (3.3 lb)	m/s ² (ft/s ²)	⁽¹⁾	
	Number of axes	–	3 (fixed option) / 4 (rotational axis installed)	
	Position repeatability (ISO 9283)	mm (in)		Position: 0.05 (0.0020)
		–		Angle: +/-0.3° ⁽³⁾
Maximum torque of the rotational axis ⁽⁴⁾	Nm (lbf-in)		4.5 (40) ⁽⁵⁾	
Electrical data	Mains voltage - 3-phase	Vac	480 ⁽⁶⁾	
	Control voltage (with brake)	Vdc	+24 (-10...+6%)	
	Motor main axes	–	SH30553P02F2000	
	Motor rotational axis	–	MH30701P02F2200	
	Power consumption for a typical pick & place cycle with 1.5 kg (3.3 lb)	kW (hp)		0.22 (0.295)
Mechanical data	Installation type	–	Ceiling installation	
	Protection class for moving parts	–	IP69k	
	Basic protection class	–	IP65	
	Housing type	–	Compact	

Category	Parameter	Unit	VRKP0S0FNC00E00 VRKP0S0RNC00E00
Working space	Height x diameter	mm (in)	160 x 400 (6.3 x 15.7) 180 x 292 (7.1 x 11.5)
	Rotation	–	Unlimited
Weight	–	kg (lb)	approximately 27.8 (61.29)
Noise level	–	dB(A)	< 70
Material	External casing	–	Stainless steel 1.4301 aluminum, POM-C, FPM, TPE, PE, PEEK
<p>(1) Loads above the maximum load are possible with restrictions. If required, contact your local Schneider Electric service representative.</p> <p>(2) For a load mounted centrally underneath the flange and a distance of maximum 100 mm (3.9 in) between flange and mass center of gravity.</p> <p>(3) +/-0.1° is possible with optional equipment. For further information, refer to <i>Rotational Module</i>, page 157, <i>Tilting Module</i>, page 165, <i>Double Rotational Module</i>, page 173 and <i>Rotational Tilting Module</i>, page 184.</p> <p>(4) When designing the gripper, be aware of any appearance of mass moments of inertia as well as friction, which could lead to exceeding the maximum torque and consequential damage.</p> <p>(5) Maximum torque of the rotational axis with the optional Telescopic Axis Double is 3 Nm (31 lbf-in). For further information, refer to <i>Mounting the Telescopic Axis Double</i>, page 155.</p> <p>(6) For further information, refer to <i>Lexium 52 Hardware Guide</i> or <i>Lexium 62 Hardware Guide</i>.</p>			

Robot VRKP1...WF

Mechanical and Electrical Data of VRKP1...WF

Category	Parameter	Unit	VRKP1S0FWF
			VRKP1S0RWF
General data	Rated load	kg (lb)	1.5 (3.3)
	Maximum load ⁽¹⁾	kg (lb)	10 (22)
	Maximum velocity	m/s (ft/s)	6 (20)
	Maximum acceleration ⁽²⁾ for 1 kg (2.2 lb)	m/s ² (ft/s ²)	125 (410)
	Maximum acceleration ⁽²⁾ for 1.5 kg (3.3 lb)	m/s ² (ft/s ²)	120 (394)
	Maximum acceleration ⁽²⁾ for > 1.5 kg (3.3 lb)	m/s ² (ft/s ²)	⁽¹⁾
	Number of axes	–	3 (fixed option) / 4 (rotational axis installed)
	Position repeatability (ISO 9283)	mm (in)	Position: 0.05 (0.0020)
		–	Angle: +/-0.3° ⁽³⁾
Maximum torque of the rotational axis ⁽⁴⁾	Nm (lbf-in)	4.5 (40) ⁽⁵⁾	
Electrical data	Mains voltage - 3-phase	Vac	480 ⁽⁶⁾
	Control voltage (with brake)	Vdc	+24 (-10...+6%)
	Fan voltage	Vdc	+24 (-10...+6%)
	Motor main axes	–	SH30553P02F2000
	Motor rotational axis	–	MH30701P02F2200
	Power consumption for a typical pick & place cycle with 1.5 kg (3.3 lb)	kW (hp)	0.22 (0.295)
Mechanical data	Installation type	–	Ceiling installation
	Protection class for moving parts	–	IP69k
	Basic protection class	–	IP65
	Housing type	–	Compact
Working space	Height x diameter	mm (in)	125 x 600 (4.9 x 23.6) 160 x 462 (6.3 x 18.2)
		Rotation	– Unlimited
Weight	–	kg (lb)	approximately 60.4 (133)
Noise level	–	dB(A)	< 70

Category	Parameter	Unit	VRKP1S0FWF VRKP1S0RWF
Material	External casing	–	Stainless steel 1.4301 aluminum, POM-C, FPM, TPE, PE, PEEK
<p>(1) Loads above the maximum load are possible with restrictions. If required, contact your local Schneider Electric service representative.</p> <p>(2) For a load mounted centrally underneath the flange and a distance of maximum 100 mm (3.9 in) between flange and mass center of gravity.</p> <p>(3) $\pm 0.1^\circ$ is possible with optional equipment. For further information, refer to <i>Rotational Module</i>, page 157, <i>Tilting Module</i>, page 165, <i>Double Rotational Module</i>, page 173 and <i>Rotational Tilting Module</i>, page 184.</p> <p>(4) When designing the gripper, be aware of any appearance of mass moments of inertia as well as friction, which could lead to exceeding the maximum torque and consequential damage.</p> <p>(5) Maximum torque of the rotational axis with the optional Telescopic Axis Double is 3 Nm (31 lbf-in). For further information, refer to <i>Mounting the Telescopic Axis Double</i>, page 155.</p> <p>(6) For further information, refer to <i>Lexium 52 Hardware Guide</i> or <i>Lexium 62 Hardware Guide</i>.</p>			

Robot VRKP1...NC

Mechanical and Electrical Data of VRKP1...NC

Category	Parameter	Unit	VRKP1S0FNC VRKP1S0RNC	
General data	Rated load	kg (lb)	1.5 (3.3)	
	Maximum load ⁽¹⁾	kg (lb)	10 (22)	
	Maximum velocity	m/s (ft/s)	6 (20)	
	Maximum acceleration ⁽²⁾ for 1 kg (2.2 lb)	m/s ² (ft/s ²)	125 (410)	
	Maximum acceleration ⁽²⁾ for 1.5 kg (3.3 lb)	m/s ² (ft/s ²)	120 (394)	
	Maximum acceleration ⁽²⁾ for > 1.5 kg (3.3 lb)	m/s ² (ft/s ²)	⁽¹⁾	
	Number of axes	–	3 (fixed option) / 4 (rotational axis installed)	
	Position repeatability (ISO 9283)		mm (in)	Position: 0.05 (0.0020)
			–	Angle: $\pm 0.3^\circ$ ⁽³⁾
Maximum torque of the rotational axis ⁽⁴⁾	Nm (lbf-in)	4.5 (40) ⁽⁵⁾		
Electrical data	Mains voltage - 3-phase	Vac	480 ⁽⁶⁾	
	Control voltage (with brake)	Vdc	+24 (-10...+6%)	
	Motor main axes	–	SH30553P02F2000	
	Motor rotational axis	–	MH30701P02F2200	
	Power consumption for a typical pick & place cycle with 1.5 kg (3.3 lb)	kW (hp)	0.22 (0.295)	
Mechanical data	Installation type	–	Ceiling installation	
	Protection class for moving parts	–	IP69k	
	Basic protection class	–	IP65	
	Housing type	–	Compact	

Category	Parameter	Unit	VRKP1S0FNC
			VRKP1S0RNC
Working space	Height x diameter	mm (in)	125 x 600 (4.9 x 23.6) 160 x 462 (6.3 x 18.2)
	Rotation	–	Unlimited
Weight	–	kg (lb)	approximately 27.9 (61.51)
Noise level	–	dB(A)	< 70
Material	External casing	–	Stainless steel 1.4301 aluminum, POM-C, FPM, TPE, PE, PEEK
<p>(1) Loads above the maximum load are possible with restrictions. If required, contact your local Schneider Electric service representative.</p> <p>(2) For a load mounted centrally underneath the flange and a distance of maximum 100 mm (3.9 in) between flange and mass center of gravity.</p> <p>(3) +/-0.1° is possible with optional equipment. For further information, refer to <i>Rotational Module</i>, page 157, <i>Tilting Module</i>, page 165, <i>Double Rotational Module</i>, page 173 and <i>Rotational Tilting Module</i>, page 184.</p> <p>(4) When designing the gripper, be aware of any appearance of mass moments of inertia as well as friction, which could lead to exceeding the maximum torque and consequential damage.</p> <p>(5) Maximum torque of the rotational axis with the optional Telescopic Axis Double is 3 Nm (31 lbf-in). For further information, refer to <i>Mounting the Telescopic Axis Double</i>, page 155.</p> <p>(6) For further information, refer to <i>Lexium 52 Hardware Guide</i> or <i>Lexium 62 Hardware Guide</i>.</p>			

Robot VRKP1...WF...E00

Mechanical and Electrical Data of VRKP1...WF...E00

Category	Parameter	Unit	VRKP1S0FWF...E00
			VRKP1S0RWF...E00
General data	Rated load	kg (lb)	1.5 (3.3)
	Maximum load ⁽¹⁾	kg (lb)	10 (22)
	Maximum velocity	m/s (ft/s)	6 (20)
	Maximum acceleration ⁽²⁾ for 1 kg (2.2 lb)	m/s ² (ft/s ²)	125 (410)
	Maximum acceleration ⁽²⁾ for 1.5 kg (3.3 lb)	m/s ² (ft/s ²)	120 (394)
	Maximum acceleration ⁽²⁾ for > 1.5 kg (3.3 lb)	m/s ² (ft/s ²)	⁽¹⁾
	Number of axes	–	3 (fixed option) / 4 (rotational axis installed)
	Position repeatability (ISO 9283)	mm (in)	Position: 0.05 (0.0020)
		–	Angle: +/-0.3° ⁽³⁾
Maximum torque of the rotational axis ⁽⁴⁾	Nm (lbf-in)	4.5 (40) ⁽⁵⁾	
Electrical data	Mains voltage - 3-phase	Vac	480 ⁽⁶⁾
	Control voltage (with brake)	Vdc	+24 (-10...+6%)
	Fan voltage	Vdc	+24 (-10...+6%)
	Motor main axes	–	SH30553P02F2000
	Motor rotational axis	–	MH30701P02F2200
	Power consumption for a typical pick & place cycle with 1.5 kg (3.3 lb)	kW (hp)	0.22 (0.295)
Mechanical data	Installation type	–	Ceiling installation
	Protection class for moving parts	–	IP69k
	Basic protection class	–	IP65
	Housing type	–	Compact
Working space	Height x diameter	mm (in)	190 x 600 (7.5 x 23.6) 220 x 472 (8.7 x 18.6)
		–	Unlimited
Weight	–	kg (lb)	approximately 60.8 (134)
Noise level	–	dB(A)	< 70

Category	Parameter	Unit	VRKP1S0FWF**E00 VRKP1S0RWF**E00
Material	External casing	–	Stainless steel 1.4301 aluminum, POM-C, FPM, TPE, PE, PEEK
<p>(1) Loads above the maximum load are possible with restrictions. If required, contact your local Schneider Electric service representative.</p> <p>(2) For a load mounted centrally underneath the flange and a distance of maximum 100 mm (3.9 in) between flange and mass center of gravity.</p> <p>(3) +/-0.1° is possible with optional equipment. For further information, refer to <i>Rotational Module</i>, page 157, <i>Tilting Module</i>, page 165, <i>Double Rotational Module</i>, page 173 and <i>Rotational Tilting Module</i>, page 184.</p> <p>(4) When designing the gripper, be aware of any appearance of mass moments of inertia as well as friction, which could lead to exceeding the maximum torque and consequential damage.</p> <p>(5) Maximum torque of the rotational axis with the optional Telescopic Axis Double is 3 Nm (31 lbf-in). For further information, refer to <i>Mounting the Telescopic Axis Double</i>, page 155.</p> <p>(6) For further information, refer to <i>Lexium 52 Hardware Guide</i> or <i>Lexium 62 Hardware Guide</i>.</p>			

Robot VRKP1***NC**E00

Mechanical and Electrical Data of VRKP1***NC**E00

Category	Parameter	Unit	VRKP1S0FNC00E00 VRKP1S0RNC00E00	
General data	Rated load	kg (lb)	1.5 (3.3)	
	Maximum load ⁽¹⁾	kg (lb)	10 (22)	
	Maximum velocity	m/s (ft/s)	6 (20)	
	Maximum acceleration ⁽²⁾ for 1 kg (2.2 lb)	m/s ² (ft/s ²)	125 (410)	
	Maximum acceleration ⁽²⁾ for 1.5 kg (3.3 lb)	m/s ² (ft/s ²)	120 (394)	
	Maximum acceleration ⁽²⁾ for > 1.5 kg (3.3 lb)	m/s ² (ft/s ²)	⁽¹⁾	
	Number of axes	–	3 (fixed option) / 4 (rotational axis installed)	
	Position repeatability (ISO 9283)	mm (in)		Position: 0.05 (0.0020)
		–		Angle: +/-0.3° ⁽³⁾
Maximum torque of the rotational axis ⁽⁴⁾	Nm (lbf-in)		4.5 (40) ⁽⁵⁾	
Electrical data	Mains voltage - 3-phase	Vac	480 ⁽⁶⁾	
	Control voltage (with brake)	Vdc	+24 (-10...+6%)	
	Motor main axes	–	SH30553P02F2000	
	Motor rotational axis	–	MH30701P02F2200	
	Power consumption for a typical pick & place cycle with 1.5 kg (3.3 lb)	kW (hp)		0.22 (0.295)
Mechanical data	Installation type	–	Ceiling installation	
	Protection class for moving parts	–	IP69k	
	Basic protection class	–	IP65	
	Housing type	–	Compact	

Category	Parameter	Unit	VRKP1S0FNC00E00 VRKP1S0RNC00E00
Working space	Height x diameter	mm (in)	190 x 600 (7.5 x 23.6) 220 x 472 (8.7 x 18.6)
	Rotation	–	Unlimited
Weight	–	kg (lb)	approximately 28.3 (62)
Noise level	–	dB(A)	< 70
Material	External casing	–	Stainless steel 1.4301 aluminum, POM-C, FPM, TPE, PE, PEEK
<p>(1) Loads above the maximum load are possible with restrictions. If required, contact your local Schneider Electric service representative.</p> <p>(2) For a load mounted centrally underneath the flange and a distance of maximum 100 mm (3.9 in) between flange and mass center of gravity.</p> <p>(3) +/-0.1° is possible with optional equipment. For further information, refer to <i>Rotational Module</i>, page 157, <i>Tilting Module</i>, page 165, <i>Double Rotational Module</i>, page 173 and <i>Rotational Tilting Module</i>, page 184.</p> <p>(4) When designing the gripper, be aware of any appearance of mass moments of inertia as well as friction, which could lead to exceeding the maximum torque and consequential damage.</p> <p>(5) Maximum torque of the rotational axis with the optional Telescopic Axis Double is 3 Nm (31 lbf-in). For further information, refer to <i>Mounting the Telescopic Axis Double</i>, page 155.</p> <p>(6) For further information, refer to <i>Lexium 52 Hardware Guide</i> or <i>Lexium 62 Hardware Guide</i>.</p>			

Robot VRKP2...WD

Mechanical and Electrical Data of VRKP2...WD

Category	Parameter	Unit	VRKP2S0FWD VRKP2S0RWD
General data	Rated load	kg (lb)	1.5 (3.3)
	Maximum load ⁽¹⁾	kg (lb)	15 (33)
	Maximum velocity	m/s (ft/s)	10 (33)
	Maximum acceleration ⁽²⁾ for 1 kg (2.2 lb)	m/s ² (ft/s ²)	120 (394)
	Maximum acceleration ⁽²⁾ for 1.5 kg (3.3 lb)	m/s ² (ft/s ²)	90 (295)
	Maximum acceleration ⁽²⁾ for > 1.5 kg (3.3 lb)	m/s ² (ft/s ²)	⁽¹⁾
	Number of axes	–	3 (fixed option) / 4 (rotational axis installed)
	Position repeatability (ISO 9283)	–	Position: 0.1 (0.0039)
		–	Angle: +/-0.3° ⁽³⁾
Maximum torque of the rotational axis ⁽⁴⁾	Nm (lbf-in)	4.5 (40) ⁽⁵⁾	
Electrical data	Mains voltage - 3-phase	Vac	480 ⁽⁶⁾
	Control voltage (with brake)	Vdc	+24 (-10...+6%)
	Fan voltage	Vdc	+24 (-10...+6%)
	Motor main axes	–	SH30703P02F2000
	Motor rotational axis	–	SH30702P02F2000
	Power consumption for a typical pick & place cycle with 1.5 kg (3.3 lb)	kW (hp)	0.35 (0.47)
Mechanical data	Installation type	–	Ceiling installation
	Protection class for moving parts	–	IP69k
	Basic protection class	–	IP65
	Maximum permissible overpressure in the robot housing	bar (psi)	0.1 (1.45)
	Housing type	–	Wash-down standard
Working space	Height x diameter	mm (in)	155 x 800 (6.1 x 31.5) 230 x 500 (9 x 19.7)
		–	Unlimited
Weight	–	kg (lb)	approximately 110 (243)
Noise level	–	dB(A)	< 70

Category	Parameter	Unit	VRKP2S0FWD VRKP2S0RWD
Material	External casing	–	Stainless steel 1.4301, POM-C, PTFE, FPM, EPDM, PVDF, TPE, PE, PEEK
<p>(1) Loads above the maximum load are possible with restrictions. If required, contact your local Schneider Electric service representative.</p> <p>(2) For a load mounted centrally underneath the flange and a distance of maximum 100 mm (3.9 in) between flange and mass center of gravity.</p> <p>(3) $\pm 0.1^\circ$ is possible with optional equipment. For further information, refer to <i>Rotational Module</i>, page 157, <i>Tilting Module</i>, page 165, <i>Double Rotational Module</i>, page 173 and <i>Rotational Tilting Module</i>, page 184.</p> <p>(4) When designing the gripper, be aware of any appearance of mass moments of inertia as well as friction, which could lead to exceeding the maximum torque and consequential damage.</p> <p>(5) Maximum torque of the rotational axis with the optional Telescopic Axis Double is 3 Nm (31 lbf-in). For further information, refer to <i>Mounting the Telescopic Axis Double</i>, page 155.</p> <p>(6) For further information, refer to <i>Lexium 52 Hardware Guide</i> or <i>Lexium 62 Hardware Guide</i>.</p>			

Robot VRKP2...NC

Mechanical and Electrical Data of VRKP2...NC

Category	Parameter	Unit	VRKP2S0FNC VRKP2S0RNC	VRKP2L0FNC VRKP2L0RNC
General data	Rated load	kg (lb)	1.5 (3.3)	
	Maximum load ⁽¹⁾	kg (lb)	15 (33)	
	Maximum velocity	m/s (ft/s)	10 (33)	
	Maximum acceleration ⁽²⁾ for 1 kg (2.2 lb)	m/s ² (ft/s ²)	120 (394)	
	Maximum acceleration ⁽²⁾ for 1.5 kg (3.3 lb)	m/s ² (ft/s ²)	90 (295)	
	Maximum acceleration ⁽²⁾ for > 1.5 kg (3.3 lb)	m/s ² (ft/s ²)	⁽¹⁾	
	Number of axes	–	3 (fixed option) / 4 (rotational axis installed)	
	Position repeatability (ISO 9283)	–	Position: 0.1 (0.0039)	
		–	Angle: $\pm 0.3^\circ$ ⁽³⁾	
Maximum torque of the rotational axis ⁽⁴⁾	Nm (lbf-in)	4.5 (40) ⁽⁵⁾		
Electrical data	Mains voltage - 3-phase	Vac	480 ⁽⁶⁾	
	Control voltage (with brake)	Vdc	+24 (-10...+6%)	+24 (-20...+25%)
	Motor main axes	–	SH30703P02F2000	ILM0703P02F0000
	Motor rotational axis	–	SH30702P02F2000	ILM0702P02F0000
	Power consumption for a typical pick & place cycle with 1.5 kg (3.3 lb)	kW (hp)	0.35 (0.47)	
Mechanical data	Installation type	–	Ceiling installation	
	Protection class for moving parts	–	IP69k	
	Basic protection class	–	IP65	
	Housing type	–	Compact	

Category	Parameter	Unit	VRKP2S0FNC	VRKP2L0FNC
			VRKP2S0RNC	VRKP2L0RNC
Working space	Height x diameter	mm (in)	155 x 800 (6.1 x 31.5) 230 x 500 (9 x 19.7)	
	Rotation	–	Unlimited	
Weight	–	kg (lb)	approximately 70 (154)	
Noise level	–	dB(A)	< 70	
Material	External casing	–	Stainless steel 1.4301, aluminum, POM-C, FPM, TPE, PE, PEEK	
<p>(1) Loads above the maximum load are possible with restrictions. If required, contact your local Schneider Electric service representative.</p> <p>(2) For a load mounted centrally underneath the flange and a distance of maximum 100 mm (3.9 in) between flange and mass center of gravity.</p> <p>(3) +/-0.1° is possible with optional equipment. For further information, refer to <i>Rotational Module</i>, page 157, <i>Tilting Module</i>, page 165, <i>Double Rotational Module</i>, page 173 and <i>Rotational Tilting Module</i>, page 184.</p> <p>(4) When designing the gripper, be aware of any appearance of mass moments of inertia as well as friction, which could lead to exceeding the maximum torque and consequential damage.</p> <p>(5) Maximum torque of the rotational axis with the optional Telescopic Axis Double is 3 Nm (31 lbf-in). For further information, refer to <i>Mounting the Telescopic Axis Double</i>, page 155.</p> <p>(6) For further information, refer to <i>Lexium 52 Hardware Guide</i> or <i>Lexium 62 Hardware Guide</i>.</p>				

Robot VRKP4...WD / VRKP4...NO / VRKP4...CW

Mechanical and Electrical Data of VRKP4...WD / VRKP4...NO / VRKP4...CW

Category	Parameter	Unit	VRKP4S0FWD VRKP4S0FCW VRKP4S0RWD VRKP4S0RCW	VRKP4L0FNO VRKP4L0RNO
General data	Rated load	kg (lb)	1.5 (3.3)	
	Maximum load ⁽¹⁾	kg (lb)	15 (33)	
	Maximum velocity	m/s (ft/s)	10 (33)	
	Maximum acceleration ⁽²⁾ for 1 kg (2.2 lb)	m/s ² (ft/s ²)	100 (328)	
	Maximum acceleration ⁽²⁾ for 1.5 kg (3.3 lb)	m/s ² (ft/s ²)	75 (246)	
	Maximum acceleration ⁽²⁾ for > 1.5 kg (3.3 lb)	m/s ² (ft/s ²)	⁽¹⁾	
	Number of axes	–	3 (fixed option) / 4 (rotational axis installed)	
	Position repeatability (ISO 9283)	mm (in)	Position: 0.1 (0.0039)	
		–	Angle: +/-0.3° ⁽³⁾	
Maximum torque of the rotational axis ⁽⁴⁾	Nm (lbf-in)	4.5 (40) ⁽⁵⁾		
Electrical data	Mains voltage - 3-phase	Vac	480 ⁽⁶⁾	
	Control voltage (with brake)	Vdc	+24 (-10...+6%)	+24 (-20...+25%)
	Fan voltage	Vdc	–	+24 (-10...+6%)
	Motor main axes	–	SH30703P02F2000	ILM0703P02F0000
	Motor rotational axis	–	SH30702P02F2000	ILM0702P02F0000
	Power consumption for a typical pick & place cycle with 1.5 kg (3.3 lb)	kW (hp)	0.35 (0.47)	
Mechanical data	Installation type	–	Ceiling installation	
	Protection class for moving parts	–	IP69k	
	Basic protection class	–	IP65	IP22
	Maximum permissible overpressure in the robot housing	bar (psi)	0.1 (1.45)	
	Housing type	–	Wash-down standard	Open standard
Working space	Height x diameter	mm (in)	225 x 1200 (8.9 x 47)	
			350 x 750 (13.8 x 29.5)	
	Rotation	–	Unlimited	
Weight	–	kg (lb)	approximately 120 (265)	
Noise level	–	dB(A)	< 70	

Category	Parameter	Unit	VRKP4S0FWD VRKP4S0FCW VRKP4S0RWD VRKP4S0RCW	VRKP4L0FNO VRKP4L0RNO
Material	External casing	–	Stainless steel 1.4301, POM-C, PTFE, FPM, EPDM, PVDF, TPE, PE, PEEK	
<p>(1) Loads above the maximum load are possible with restrictions. If required, contact your local Schneider Electric service representative.</p> <p>(2) For a load mounted centrally underneath the flange and a distance of maximum 100 mm (3.9 in) between flange and mass center of gravity.</p> <p>(3) +/-0.1° is possible with optional equipment. For further information, refer to <i>Rotational Module</i>, page 157, <i>Tilting Module</i>, page 165, <i>Double Rotational Module</i>, page 173 and <i>Rotational Tilting Module</i>, page 184.</p> <p>(4) When designing the gripper, be aware of any appearance of mass moments of inertia as well as friction, which could lead to exceeding the maximum torque and consequential damage.</p> <p>(5) Maximum torque of the rotational axis with the optional Telescopic Axis Double is 3 Nm (31 lbf-in). For further information, refer to <i>Mounting the Telescopic Axis Double</i>, page 155.</p> <p>(6) For further information, refer to <i>Lexium 52 Hardware Guide</i> or <i>Lexium 62 Hardware Guide</i>.</p>				

Robot VRKP4...WF

Mechanical and Electrical Data of VRKP4...WF

Category	Parameter	Unit	VRKP4S0FWF VRKP4S0RWF	
General data	Rated load	kg (lb)	1.5 (3.3)	
	Maximum load ⁽¹⁾	kg (lb)	15 (33)	
	Maximum velocity	m/s (ft/s)	10 (33)	
	Maximum acceleration ⁽²⁾ for 1 kg (2.2 lb)	m/s ² (ft/s ²)	100 (328)	
	Maximum acceleration ⁽²⁾ for 1.5 kg (3.3 lb)	m/s ² (ft/s ²)	75 (246)	
	Maximum acceleration ⁽²⁾ for > 1.5 kg (3.3 lb)	m/s ² (ft/s ²)	(1)	
	Number of axes	–	3 (fixed option) / 4 (rotational axis installed)	
	Position repeatability (ISO 9283)		mm (in)	Position: 0.1 (0.0039)
			–	Angle: +/-0.3° ⁽³⁾
	Maximum torque of the rotational axis ⁽⁴⁾	Nm (lbf-in)	4.5 (40) ⁽⁵⁾	
Electrical data	Mains voltage - 3-phase	Vac	480 ⁽⁶⁾	
	Control voltage (with brake)	Vdc	+24 (-10...+6%)	
	Fan voltage	Vdc	+24 (-10...+6%)	
	Motor main axes	–	SH30703P02F2000	
	Motor rotational axis	–	MH30701P02F2200	
	Power consumption for a typical pick & place cycle with 1.5 kg (3.3 lb)	kW (hp)	0.35 (0.47)	

Category	Parameter	Unit	VRKP4S0FWF VRKP4S0RWF
Mechanical data	Installation type	–	Ceiling installation
	Protection class for moving parts	–	IP69k
	Basic protection class	–	IP65
	Maximum permissible overpressure in the robot housing	bar (psi)	0.1 (1.45)
	Housing type	–	Wash-down flat
Working space	Height x diameter	mm (in)	225 x 1200 (8.9 x 47)
			350 x 750 (13.8 x 29.5)
	Rotation	–	Unlimited
Weight	–	kg (lb)	approximately 100 (220)
Noise level	–	dB(A)	< 70
Material	External casing	–	Stainless steel 1.4301, POM-C, PTFE, FPM, EPDM, PVDF, TPE, PE, PEEK
<p>(1) Loads above the maximum load are possible with restrictions. If required, contact your local Schneider Electric service representative.</p> <p>(2) For a load mounted centrally underneath the flange and a distance of maximum 100 mm (3.9 in) between flange and mass center of gravity.</p> <p>(3) $\pm 0.1^\circ$ is possible with optional equipment. For further information, refer to <i>Rotational Module</i>, page 157, <i>Tilting Module</i>, page 165, <i>Double Rotational Module</i>, page 173 and <i>Rotational Tilting Module</i>, page 184.</p> <p>(4) When designing the gripper, be aware of any appearance of mass moments of inertia as well as friction, which could lead to exceeding the maximum torque and consequential damage.</p> <p>(5) Maximum torque of the rotational axis with the optional Telescopic Axis Double is 3 Nm (31 lbf-in). For further information, refer to <i>Mounting the Telescopic Axis Double</i>, page 155.</p> <p>(6) For further information, refer to <i>Lexium 52 Hardware Guide</i> or <i>Lexium 62 Hardware Guide</i>.</p>			

Robot VRKP4...NC

Mechanical and Electrical Data of VRKP4...NC

Category	Parameter	Unit	VRKP4S0FNC VRKP4S0RNC	VRKP4L0FNC VRKP4L0RNC	VRKP4S0 MNC00045
General data	Rated load	kg (lb)	1.5 (3.3)		
	Maximum load ⁽¹⁾	kg (lb)	15 (33)		12 (29)
	Maximum velocity	m/s (ft/s)	10 (33)		
	Maximum acceleration ⁽²⁾ for 1 kg (2.2 lb)	m/s ² (ft/s ²)	100 (328)		
	Maximum acceleration ⁽²⁾ for 1.5 kg (3.3 lb)	m/s ² (ft/s ²)	75 (246)		
	Maximum acceleration ⁽²⁾ for > 1.5 kg (3.3 lb)	m/s ² (ft/s ²)	⁽¹⁾		
	Number of axes	–	3 (fixed option) / 4 (rotational axis installed)		4
	Position repeatability (ISO 9283)	mm (in)	Position: 0.1 (0.0039)		
		–	Angle: +/-0.3° ⁽³⁾		Angle: +/-0.1°
	Maximum torque of the rotational axis ⁽⁴⁾	Nm (lbf-in)	4.5 (40) ⁽⁵⁾		16
Electrical data	Mains voltage - 3-phase	Vac	480 ⁽⁶⁾		
	Control voltage (with brake)	Vdc	+24 (-10...+6%)	+24 (-20...+25%)	+24 (-10...+6%)
	Motor main axes	–	SH30703P02 F2000	ILM0703P02 F0000	SH30703P02 F2000
	Motor rotational axis	–	SH30702P02 F2000	ILM0702P02 F0000	SH30402P07 F2000
	Power consumption for a typical pick & place cycle with 1.5 kg (3.3 lb)	kW (hp)	0.35 (0.47)		
Mechanical data	Installation type	–	Ceiling installation		
	Protection class for moving parts	–	IP69k		
	Basic protection class	–	IP65		
	Housing type	–	Compact		
Working space	Height x diameter	mm (in)	225 x 1200 (7.1 x 47)		
			350 x 750 (13.8 x 29.5)		
	Rotation	–	Unlimited		
Weight	–	kg (lb)	approximately 75 (165)		
Noise level	–	dB(A)	< 70 dB(A)		

Category	Parameter	Unit	VRKP4S0FNC	VRKP4L0FNC	VRKP4S0 MNC00045
			VRKP4S0RNC	VRKP4L0RNC	
Material	External casing	–	Stainless steel 1.4301, aluminum, POM-C, FPM, TPE, PE, PEEK		Stainless steel 1.4301, aluminum, steel nickel-plated, zinc nickel-plated, POM-C, FPM, TPE, PE, PEEK, EPDM
<p>(1) Loads above the maximum load are possible with restrictions. If required, contact your local Schneider Electric service representative.</p> <p>(2) For a load mounted centrally underneath the flange and a distance of maximum 100 mm (3.9 in) between flange and mass center of gravity.</p> <p>(3) $\pm 0.1^\circ$ is possible with optional equipment. For further information, refer to <i>Rotational Module</i>, page 157, <i>Tilting Module</i>, page 165, <i>Double Rotational Module</i>, page 173 and <i>Rotational Tilting Module</i>, page 184.</p> <p>(4) When designing the gripper, be aware of any appearance of mass moments of inertia as well as friction, which could lead to exceeding the maximum torque and consequential damage.</p> <p>(5) Maximum torque of the rotational axis with the optional Telescopic Axis Double is 3 Nm (31 lbf-in). For further information, refer to <i>Mounting the Telescopic Axis Double</i>, page 155.</p> <p>(6) For further information, refer to <i>Lexium 52 Hardware Guide</i> or <i>Lexium 62 Hardware Guide</i>.</p>					

Robot VRKP5...WF

Mechanical and Electrical Data of VRKP5...WF

Category	Parameter	Unit	VRKP5S0FWF
			VRKP5S0RWF
General data	Rated load	kg (lb)	1.5 (3.3)
	Maximum load ⁽¹⁾	kg (lb)	15 (33)
	Maximum velocity	m/s (ft/s)	10 (33)
	Maximum acceleration ⁽²⁾ for 1 kg (2.2 lb)	m/s ² (ft/s ²)	90 (295)
	Maximum acceleration ⁽²⁾ for 1.5 kg (3.3 lb)	m/s ² (ft/s ²)	70 (230)
	Maximum acceleration ⁽²⁾ for > 1.5 kg (3.3 lb)	m/s ² (ft/s ²)	⁽¹⁾
	Number of axes	–	3 (fixed option) / 4 (rotational axis installed)
	Position repeatability (ISO 9283)	mm (in)	Position: 0.1 (0.0039)
		–	Angle: $\pm 0.3^\circ$ ⁽³⁾
Maximum torque of the rotational axis ⁽⁴⁾	Nm (lbf-in)	4.5 (40) ⁽⁵⁾	
Electrical data	Mains voltage - 3-phase	Vac	480 ⁽⁶⁾
	Control voltage (with brake)	Vdc	+24 (-10...+6%)
	Fan voltage	Vdc	+24 (-10...+6%)
	Motor main axes	–	SH30703P02F2000
	Motor rotational axis	–	MH30701P02F2200
	Power consumption for a typical pick & place cycle with 1.5 kg (3.3 lb)	kW (hp)	0.35 (0.47)

Category	Parameter	Unit	VRKP5S0FWF
			VRKP5S0RWF
Mechanical data	Installation type	–	Ceiling installation
	Protection class for moving parts	–	IP69k
	Basic protection class	–	IP65
	Maximum permissible overpressure in the robot housing	bar (psi)	0.1 (1.45)
	Housing type	–	Wash-down flat
Working space	Height x diameter	mm (in)	225 x 1400 (8.9 x 55) 400 x 800 (15.7 x 31.5)
			Rotation
Weight	–	kg (lb)	approximately 115 (254)
Noise level	–	dB(A)	< 70 dB(A)
Material	External casing	–	Stainless steel 1.4301, aluminum, POM-C, FPM, TPE, PE, PEEK
<p>(1) Loads above the maximum load are possible with restrictions. If required, contact your local Schneider Electric service representative.</p> <p>(2) For a load mounted centrally underneath the flange and a distance of maximum 100 mm (3.9 in) between flange and mass center of gravity.</p> <p>(3) +/-0.1° is possible with optional equipment. For further information, refer to <i>Rotational Module</i>, page 157, <i>Tilting Module</i>, page 165, <i>Double Rotational Module</i>, page 173 and <i>Rotational Tilting Module</i>, page 184.</p> <p>(4) When designing the gripper, be aware of any appearance of mass moments of inertia as well as friction, which could lead to exceeding the maximum torque and consequential damage.</p> <p>(5) Maximum torque of the rotational axis with the optional Telescopic Axis Double is 3 Nm (31 lbf-in). For further information, refer to <i>Mounting the Telescopic Axis Double</i>, page 155.</p> <p>(6) For further information, refer to <i>Lexium 52 Hardware Guide</i> or <i>Lexium 62 Hardware Guide</i>.</p>			

Robot VRKP5...NC

Mechanical and Electrical Data of VRKP5...NC

Category	Parameter	Unit	VRKP5S0FNC	VRKP5L0FNC
			VRKP5S0RNC	VRKP5L0RNC
General data	Rated load	kg (lb)	1.5 (3.3)	
	Maximum load ⁽¹⁾	kg (lb)	15 (33)	
	Maximum velocity	m/s (ft/s)	10 (33)	
	Maximum acceleration ⁽²⁾ for 1 kg (2.2 lb)	m/s ² (ft/s ²)	90 (295)	
	Maximum acceleration ⁽²⁾ for 1.5 kg (3.3 lb)	m/s ² (ft/s ²)	70 (230)	
	Maximum acceleration ⁽²⁾ for > 1.5 kg (3.3 lb)	m/s ² (ft/s ²)	⁽¹⁾	
	Number of axes	–	3 (fixed option) / 4 (rotational axis installed)	
	Position repeatability (ISO 9283)	mm (in)	Position: 0.1 (0.0039)	
		–	Angle: +/-0.3° ⁽³⁾	
Maximum torque of the rotational axis ⁽⁴⁾	Nm (lbf-in)	4.5 (40) ⁽⁵⁾		
Electrical data	Mains voltage - 3-phase	Vac	480 ⁽⁶⁾	
	Control voltage (with brake)	Vdc	+24 (-10...+6%)	+24 (-20...+25%)
	Motor main axes	–	SH30703P02F2000	ILM0703P02F0000
	Motor rotational axis	–	SH30702P02F2000	ILM0702P02F0000
	Power consumption for a typical pick & place cycle with 1.5 kg (3.3 lb)	kW (hp)	0.35 (0.47)	
Mechanical data	Installation type	–	Ceiling installation	
	Protection class for moving parts	–	IP69k	
	Basic protection class	–	IP65	
	Housing type	–	Compact	
Working space	Height x diameter	mm (in)	225 x 1400 (8.9 x 55)	
			400 x 800 (15.7 x 31.5)	
	Rotation	–	Unlimited	
Weight	–	kg (lb)	approximately 80 (176)	
Noise level	–	dB(A)	< 70 dB(A)	

Category	Parameter	Unit	VRKP5S0FNC	VRKP5L0FNC
			VRKP5S0RNC	VRKP5L0RNC
Material	External casing	–	Stainless steel 1.4301, aluminum, POM-C, FPM, TPE, PE, PEEK	
<p>(1) Loads above the maximum load are possible with restrictions. If required, contact your local Schneider Electric service representative.</p> <p>(2) For a load mounted centrally underneath the flange and a distance of maximum 100 mm (3.9 in) between flange and mass center of gravity.</p> <p>(3) +/-0.1° is possible with optional equipment. For further information, refer to <i>Rotational Module</i>, page 157, <i>Tilting Module</i>, page 165, <i>Double Rotational Module</i>, page 173 and <i>Rotational Tilting Module</i>, page 184.</p> <p>(4) When designing the gripper, be aware of any appearance of mass moments of inertia as well as friction, which could lead to exceeding the maximum torque and consequential damage.</p> <p>(5) Maximum torque of the rotational axis with the optional Telescopic Axis Double is 3 Nm (31 lbf-in). For further information, refer to <i>Mounting the Telescopic Axis Double</i>, page 155.</p> <p>(6) For further information, refer to <i>Lexium 52 Hardware Guide</i> or <i>Lexium 62 Hardware Guide</i>.</p>				

Robot VRKP6...WF

Mechanical and Electrical Data of VRKP6...WF

Category	Parameter	Unit	VRKP6S0FWF
			VRKP6S0RWF
General data	Rated load	kg (lb)	1.5 (3.3)
	Maximum load without restrictions	kg (lb)	10 (22)
	Load with restrictions ⁽¹⁾	kg (lb)	10...15 (22...33)
	Maximum velocity	m/s (ft/s)	10 (33)
	Maximum acceleration ⁽²⁾ for 1 kg (2.2 lb)	m/s ² (ft/s ²)	80 (262)
	Maximum acceleration ⁽²⁾ for 1.5 kg (3.3 lb)	m/s ² (ft/s ²)	60 (197)
	Maximum acceleration ⁽²⁾ for > 1.5 kg (3.3 lb)	m/s ² (ft/s ²)	⁽¹⁾
	Number of axes	–	3 (fixed option) / 4 (rotational axis installed)
	Position repeatability (ISO 9283)	mm (in)	Position: 0.1 (0.0039)
		–	Angle: +/-0.3° ⁽³⁾
	Maximum torque of the rotational axis ⁽⁴⁾	Nm (lbf-in)	4.5 (40) ⁽⁵⁾
Electrical data	Mains voltage - 3-phase	Vac	480 ⁽⁶⁾
	Control voltage (with brake)	Vdc	+24 (-10...+6%)
	Fan voltage	Vdc	+24 (-10...+6%)
	Motor main axes	–	SH30703P02F2000
	Motor rotational axis	–	MH30701P02F2200
	Power consumption for a typical pick & place cycle with 1.5 kg (3.3 lb)	kW (hp)	0.35 (0.47)

Category	Parameter	Unit	VRKP6S0FWF VRKP6S0RWF
Mechanical data	Installation type	–	Ceiling installation
	Protection class for moving parts	–	IP69k
	Basic protection class	–	IP65
	Maximum permissible overpressure in the robot housing	bar (psi)	0.1 (1.45)
	Housing type	–	Wash-down flat
Working space	Height x diameter	mm (in)	275 x 1600 (10.8 x 63) 450 x 1000 (17.7 x 39)
	Rotation	–	Unlimited
Weight	–	kg (lb)	approximately 115 (254)
Noise level	–	dB(A)	< 70
Material	External casing	–	Stainless steel 1.4301, aluminum, POM-C, FPM, TPE, PE, PEEK
<p>(1) Loads above the maximum load are possible with restrictions. If required, contact your local Schneider Electric service representative.</p> <p>(2) For a load mounted centrally underneath the flange and a distance of maximum 100 mm (3.9 in) between flange and mass center of gravity.</p> <p>(3) $\pm 0.1^\circ$ is possible with optional equipment. For further information, refer to <i>Rotational Module</i>, page 157, <i>Tilting Module</i>, page 165, <i>Double Rotational Module</i>, page 173 and <i>Rotational Tilting Module</i>, page 184.</p> <p>(4) When designing the gripper, be aware of any appearance of mass moments of inertia as well as friction, which could lead to exceeding the maximum torque and consequential damage.</p> <p>(5) Maximum torque of the rotational axis with the optional Telescopic Axis Double is 3 Nm (31 lbf-in). For further information, refer to <i>Mounting the Telescopic Axis Double</i>, page 155.</p> <p>(6) For further information, refer to <i>Lexium 52 Hardware Guide</i> or <i>Lexium 62 Hardware Guide</i>.</p>			

Robot VRKP6...NC

Mechanical and Electrical Data of VRKP6...NC

Category	Parameter	Unit	VRKP6S0FNC	VRKP6L0FNC
			VRKP6S0RNC	VRKP6L0RNC
General data	Rated load	kg (lb)	1.5 (3.3)	
	Maximum load without restrictions	kg (lb)	10 (22)	
	Load with restrictions ⁽¹⁾	kg (lb)	10...15 (22...33)	
	Maximum velocity	m/s (ft/s)	10 (33)	
	Maximum acceleration ⁽²⁾ for 1 kg (2.2 lb)	m/s ² (ft/s ²)	80 (262)	
	Maximum acceleration ⁽²⁾ for 1.5 kg (3.3 lb)	m/s ² (ft/s ²)	60 (197)	
	Maximum acceleration ⁽²⁾ for > 1.5 kg (3.3 lb)	m/s ² (ft/s ²)	⁽¹⁾	
	Number of axes	–	3 (fixed option) / 4 (rotational axis installed)	
	Position repeatability (ISO 9283)	mm (in)	Position: 0.1 (0.0039)	
			Angle: +/-0.3° ⁽³⁾	
	Maximum torque of the rotational axis ⁽⁴⁾	Nm (lbf-in)	4.5 (40) ⁽⁵⁾	
Electrical data	Mains voltage - 3-phase	Vac	480 ⁽⁶⁾	
	Control voltage (with brake)	Vdc	+24 (-10...+6%)	+24 (-20...+25%)
	Motor main axes	–	SH30703P02F2000	ILM0703P02F0000
	Motor rotational axis	–	SH30702P02F2000	ILM0702P02F0000
	Power consumption for a typical pick & place cycle with 1.5 kg (3.3 lb)	kW (hp)	0.35 (0.47)	
Mechanical data	Installation type	–	Ceiling installation	
	Protection class for moving parts	–	IP69k	
	Basic protection class	–	IP65	
	Housing type	–	Compact	
Working space	Height x diameter	mm (in)	275 x 1600 (10.8 x 63)	
			450 x 1000 (17.7 x 39)	
	Rotation	–	Unlimited	
Weight	–	kg (lb)	approximately 80 (176)	
Noise level	–	dB(A)	< 70	

Category	Parameter	Unit	VRKP6S0FNC	VRKP6L0FNC
			VRKP6S0RNC	VRKP6L0RNC
Material	External casing	–	Stainless steel 1.4301, aluminum, POM-C, FPM, TPE, PE, PEEK	
<p>(1) Loads above the maximum load are possible with restrictions. If required, contact your local Schneider Electric service representative.</p> <p>(2) For a load mounted centrally underneath the flange and a distance of maximum 100 mm (3.9 in) between flange and mass center of gravity.</p> <p>(3) $\pm 0.1^\circ$ is possible with optional equipment. For further information, refer to <i>Rotational Module</i>, page 157, <i>Tilting Module</i>, page 165, <i>Double Rotational Module</i>, page 173 and <i>Rotational Tilting Module</i>, page 184.</p> <p>(4) When designing the gripper, be aware of any appearance of mass moments of inertia as well as friction, which could lead to exceeding the maximum torque and consequential damage.</p> <p>(5) Maximum torque of the rotational axis with the optional Telescopic Axis Double is 3 Nm (31 lbf-in). For further information, refer to <i>Mounting the Telescopic Axis Double</i>, page 155.</p> <p>(6) For further information, refer to <i>Lexium 52 Hardware Guide</i> or <i>Lexium 62 Hardware Guide</i>.</p>				

Robot VRKP6...WF...E00

Mechanical and Electrical Data of VRKP6...WF...E00

Category	Parameter	Unit	VRKP6S0FWF...E00 VRKP6S0RWF...E00
General data	Rated load	kg (lb)	1.5 (3.3)
	Maximum load without restrictions	kg (lb)	10 (22)
	Load with restrictions ⁽¹⁾	kg (lb)	10...15 (22...33)
	Maximum velocity	m/s (ft/s)	10 (33)
	Maximum acceleration ⁽²⁾ for 1 kg (2.2 lb)	m/s ² (ft/s ²)	75 (246)
	Maximum acceleration ⁽²⁾ for 1.5 kg (3.3 lb)	m/s ² (ft/s ²)	55 (180)
	Maximum acceleration ⁽²⁾ for > 1.5 kg (3.3 lb)	m/s ² (ft/s ²)	⁽¹⁾
	Number of axes	–	3 (fixed option) / 4 (rotational axis installed)
	Position repeatability (ISO 9283)	–	Position: 0.1 (0.0039)
		–	Angle: $\pm 0.3^\circ$ ⁽³⁾
Maximum torque of the rotational axis ⁽⁴⁾	Nm (lbf-in)	4.5 (40) ⁽⁵⁾	
Electrical data	Mains voltage - 3-phase	Vac	480 ⁽⁶⁾
	Control voltage (with brake)	Vdc	+24 (-10...+6%)
	Fan voltage	Vdc	+24 (-10...+6%)
	Motor main axes	–	SH30703P02F2000
	Motor rotational axis	–	MH30701P02F2200
	Power consumption for a typical pick & place cycle with 1.5 kg (3.3 lb)	kW (hp)	0.35 (0.47)
Mechanical data	Installation type	–	Ceiling installation
	Protection class for moving parts	–	IP69k
	Basic protection class	–	IP65
	Maximum permissible overpressure in the robot housing	bar (psi)	0.1 (1.45)
	Housing type	–	Wash-down flat

Category	Parameter	Unit	VRKP6S0FWF••E00 VRKP6S0RWF••E00
Working space	Height x diameter	mm (in)	400 x 1600 (15.7 x 63) 550 x 1150 (21.7 x 45)
	Rotation	–	Unlimited
Weight	–	kg (lb)	approximately 115 (254)
Noise level	–	dB(A)	< 70
Material	External casing	–	Stainless steel 1.4301, aluminum, POM-C, FPM, TPE, PE, PEEK
<p>(1) Loads above the maximum load are possible with restrictions. If required, contact your local Schneider Electric service representative.</p> <p>(2) For a load mounted centrally underneath the flange and a distance of maximum 100 mm (3.9 in) between flange and mass center of gravity.</p> <p>(3) +/-0.1° is possible with optional equipment. For further information, refer to <i>Rotational Module</i>, page 157, <i>Tilting Module</i>, page 165, <i>Double Rotational Module</i>, page 173 and <i>Rotational Tilting Module</i>, page 184.</p> <p>(4) When designing the gripper, be aware of any appearance of mass moments of inertia as well as friction, which could lead to exceeding the maximum torque and consequential damage.</p> <p>(5) Maximum torque of the rotational axis with the optional Telescopic Axis Double is 3 Nm (31 lbf-in). For further information, refer to <i>Mounting the Telescopic Axis Double</i>, page 155.</p> <p>(6) For further information, refer to <i>Lexium 52 Hardware Guide</i> or <i>Lexium 62 Hardware Guide</i>.</p>			

Robot VRKP6•••NC••E00

Mechanical and Electrical Data of VRKP6•••NC••E00

Category	Parameter	Unit	VRKP6S0FNC00E00 VRKP6S0RNC00E00
General data	Rated load	kg (lb)	1.5 (3.3)
	Maximum load without restrictions	kg (lb)	10 (22)
	Load with restrictions ⁽¹⁾	kg (lb)	10...15 (22...33)
	Maximum velocity	m/s (ft/s)	10 (33)
	Maximum acceleration ⁽²⁾ for 1 kg (2.2 lb)	m/s ² (ft/s ²)	75 (246)
	Maximum acceleration ⁽²⁾ for 1.5 kg (3.3 lb)	m/s ² (ft/s ²)	55 (180)
	Maximum acceleration ⁽²⁾ for > 1.5 kg (3.3 lb)	m/s ² (ft/s ²)	⁽¹⁾
	Number of axes	–	3 (fixed option) / 4 (rotational axis installed)
	Position repeatability (ISO 9283)	–	Position: 0.1 (0.0039)
		–	Angle: +/-0.3° ⁽³⁾
	Maximum torque of the rotational axis ⁽⁴⁾	Nm (lbf-in)	4.5 (40) ⁽⁵⁾
Electrical data	Mains voltage - 3-phase	Vac	480 ⁽⁶⁾
	Control voltage (with brake)	Vdc	+24 (-10...+6%)
	Motor main axes	–	SH30703P02F2000
	Motor rotational axis	–	SH30702P02F2000
	Power consumption for a typical pick & place cycle with 1.5 kg (3.3 lb)	kW (hp)	0.35 (0.47)

Category	Parameter	Unit	VRKP6S0FNC00E00 VRKP6S0RNC00E00
Mechanical data	Installation type	–	Ceiling installation
	Protection class for moving parts	–	IP69k
	Basic protection class	–	IP65
	Housing type	–	Compact
Working space	Height x diameter	mm (in)	400 x 1600 (15.7 x 63) 550 x 1150 (21.7 x 45)
	Rotation	–	Unlimited
Weight	–	kg (lb)	approximately 80 (176)
Noise level	–	dB(A)	< 70
Material	External casing	–	Stainless steel 1.4301, aluminum, POM-C, FPM, TPE, PE, PEEK
<p>(1) Loads above the maximum load are possible with restrictions. If required, contact your local Schneider Electric service representative.</p> <p>(2) For a load mounted centrally underneath the flange and a distance of maximum 100 mm (3.9 in) between flange and mass center of gravity.</p> <p>(3) +/-0.1° is possible with optional equipment. For further information, refer to <i>Rotational Module</i>, page 157, <i>Tilting Module</i>, page 165, <i>Double Rotational Module</i>, page 173 and <i>Rotational Tilting Module</i>, page 184.</p> <p>(4) When designing the gripper, be aware of any appearance of mass moments of inertia as well as friction, which could lead to exceeding the maximum torque and consequential damage.</p> <p>(5) Maximum torque of the rotational axis with the optional Telescopic Axis Double is 3 Nm (31 lbf-in). For further information, refer to <i>Mounting the Telescopic Axis Double</i>, page 155.</p> <p>(6) For further information, refer to <i>Lexium 52 Hardware Guide</i> or <i>Lexium 62 Hardware Guide</i>.</p>			

Dimension	Description	Unit	VRKP0	VRK-P-0.....E00	VRKP1	VRK-P-1.....E00	VRKP2	VRKP4	VRKP5	VRKP6	VRK-P-6.....E00
ØD	Working space diameter	mm (in)	400 (15.7)	400 (15.7)	600 (23.6)	600 (23.6)	800 (31.5)	1200 (47)	1400 (55)	1600 (63)	1600 (63)
H	Working space height	mm (in)	100 (3.9)	160 (6.3)	125 (4.9)	190 (7.5)	190 (7.5)	250 (9.8)	275 (10.8)	300 (11.8)	400 (15.7)
H0	Working space depth	mm (in)	44.5 (1.75)	38.7 (1.52)	81.5 (3.2)	70.6 (2.8)	84.9 (3.34)	175.4 (6.9)	193.1 (7.6)	250.9 (9.9)	257.9 (10.2)
ØD1	Auxiliary diameter 1	mm (in)	300 (11.8)	292 (11.5)	462 (18.2)	472 (18.6)	557 (22)	847 (33.3)	1013 (40)	1240 (49)	1235 (49)
H1	Auxiliary height 1	mm (in)	20 (0.79)	20 (0.79)	35 (1.38)	30 (1.18)	30 (1.18)	85 (3.35)	80 (3.15)	100 (3.9)	125 (4.9)
ØD2	Auxiliary diameter 2	mm (in)	188 (7.4)	200 (7.9)	318 (12.5)	338 (13.3)	415 (16.3)	574 (22.6)	734 (29)	833 (33)	826 (32.5)
H2	Auxiliary height 2	mm (in)	34 (1.34)	30 (1.18)	60 (2.36)	50 (1.97)	55 (2.17)	135 (5.3)	135 (5.3)	185 (7.3)	200 (7.9)
ØD3	Auxiliary diameter 3	mm (in)	75 (2.95)	75 (2.95)	175 (6.9)	177 (7)	240 (9.4)	293 (11.5)	413 (16.3)	342 (13.5)	307 (12)
H3	Auxiliary height 3	mm (in)	43 (1.7)	37.5 (1.48)	75 (2.95)	65 (2.56)	75 (2.95)	165 (6.5)	175 (6.9)	240 (9.4)	250 (9.8)
F1	Chamfer dimension 1	mm (in)	–	–	–	–	35 (1.38)	25 (0.98)	50 (1.97)	25 (0.98)	–
F2	Chamfer dimension 2	mm (in)	–	–	–	–	60 (2.36)	25 (0.98)	50 (1.97)	25 (1.98)	–
A	Z offset	mm (in)	438.2 (17.3)	554 (22)	528 (20.8)	646.5 (25.5)	650 (25.6)	863.5 (34)	997.4 (39)	1100 (43)	1245 (49)
B	Sphere center distance	mm (in)	427.2 (16.8)	543 (21.4)	517 (20.4)	635.5 (25)	650 (25.6)	863.5 (34)	997.4 (39)	1100 (43)	1245 (49)
R	Sphere radius	mm (in)	471.7 (18.6)	581.7 (23)	598.5 (23.6)	706.1 (28)	734.9 (29)	1038.9 (41)	1190.5 (47)	1350.9 (53)	1502.9 (59)
W	Bolt circle start angle	mm (in)	15 (0.59)	15 (0.59)	15 (0.59)	15 (0.59)	25 (0.98)	15 (0.59)	11 (0.43)	11 (0.43)	11 (0.43)
ØL	Bolt circle diameter	mm (in)	240 (9.4)	240 (9.4)	240 (9.4)	240 (9.4)	200 (7.9)	355 (14)	500 (19.7)	500 (19.7)	500 (19.7)
ØS	Collision area diameter	mm (in)	590 (32)	590 (32)	790 (31)	790 (31)	990 (39)	1390 (55)	1590 (63)	1790 (70)	1790 (70)
M	Threaded hole	–	M12 x 25	M12 x 25	M12 x 25	M12 x 25	M16 x 25	M16 x 25	M16 x 25	M16 x 25	M16 x 25
	Tightening torque	Nm (lbf-in)	54 (478)	54 (478)	54 (478)	54 (478)	100 (885)	100 (885)	100 (885)	100 (885)	100 (885)
ZC	Mounting distance compact housing	mm (in)	88 (3.46)	88 (3.46)	88 (3.46)	88 (3.46)	98 (3.86)	98 (3.86)	98 (3.86)	98 (3.86)	98 (3.86)

Dimension	Description	Unit	VRKP0	VRK-P-0.....-E00	VRKP1	VRK-P-1.....-E00	VRKP2	VRKP4	VRKP5	VRKP6	VRK-P-6.....-E00
ZF	Mounting distance flat housing	mm (in)	267 (10.5)	267 (10.5)	267 (10.5)	267 (10.5)	–	273 (10.7)	273 (10.7)	273 (10.7)	273 (10.7)
ZS	Mounting distance standard housing	mm (in)	–	–	–	–	473 (18.6)	473 (18.6)	–	–	–

Dimension	Description	Unit	VRKP0S••NC VRKP1S••NC	VRKP2S0•NC	VRKP4S0•NC	VRKP5S0•NC VRKP6S0•NC	
A	Width A	mm (in)	617 (24.3)	774 (30.5)	794 (31.3)	906 (36)	
B	Width B	mm (in)	636 (25)	790 (31)	857 (34)	922 (36)	
C	Height C	mm (in)	148 (5.8)	178 (7)	178 (7)	178 (7)	
D	Height D	mm (in)	225 (8.9)	275 (10.8)	275 (10.8)	275 (10.8)	
E	Clamping screw gearbox main axis	Wrench size	mm	3	4	4	4
		Tightening torque	Nm (lbf-in)	4.1 (36)	9.5 (84)	9.5 (84)	9.5 (84)
		Quantity	–	3			
F	Screw gearbox main axis to housing	Wrench size	mm	3	4	4	4
		Tightening torque	Nm (lbf-in)	3 (26.6)	4.7 (42)	4.7 (42)	4.7 (42)
		Quantity	–	24	48	48	48
G	Screw motor to gearbox ⁽²⁾	Wrench size	mm	4			
		Tightening torque	Nm (lbf-in)	3.5 (31)			
		Quantity	–	12 or 16 ⁽¹⁾			
H	Hex nut grounding cable motor	Wrench size	mm	7			
		Tightening torque	Nm (lbf-in)	2.5 (22)			
		Quantity	–	3 or 4 ⁽¹⁾			
I	Indexing bolt upper arm ⁽²⁾	Wrench size	mm	2.5	3	3	3
		Tightening torque	Nm (lbf-in)	Hand-tight			
		Quantity	–	3			
J	Screw for Protector Cap	Wrench size	mm	7	8	8	8
		Tightening torque	Nm (lbf-in)	2 (17.7)	3.5 (31)	3.5 (31)	3.5 (31)
		Quantity	–	24	48	48	48
K ⁽¹⁾	Clamping screw gearbox rotational axis	Wrench size	mm	3			
		Tightening torque	Nm (lbf-in)	4.5 (40)			
		Quantity	–	1			
L ⁽¹⁾	Screw gearbox rotational axis to housing	Wrench size	mm	8			
		Tightening torque	Nm (lbf-in)	3.5 (31)			
		Quantity	–	4			

(1) For robots with a rotational axis.
(2) Medium threadlocked with Loctite 243.

Dimension	Description	Unit	VRKP2L0•NC	VRKP4L0•NC	VRKP5L0•NC VRKP6L0•NC
A	Width A	mm (in)	800 (31.5)	806 (32)	918 (36)
B	Width B	mm (in)	817 (32)	884 (35)	948 (37)
C	Height C	mm (in)	178 (7)		
D	Height D	mm (in)	313 (12.3)		
E	Clamping screw gearbox main axis	Wrench size	mm	4	
		Tightening torque	Nm (lbf-in)	9.5 (84)	
		Quantity	–	3	
F	Screw gearbox main axis to housing	Wrench size	mm	4	
		Tightening torque	Nm (lbf-in)	4.7 (42)	
		Quantity	–	48	
G	Screw motor to gearbox ⁽²⁾	Wrench size	mm	4	
		Tightening torque	Nm (lbf-in)	3.5 (31)	
		Quantity	–	12 or 16 ⁽¹⁾	
H	Hex nut grounding cable motor	Wrench size	mm	7	
		Tightening torque	Nm (lbf-in)	2.5 (22)	
		Quantity	–	3 or 4 ⁽¹⁾	
I	Indexing bolt upper arm ⁽²⁾	Wrench size	mm	3	
		Tightening torque	Nm (lbf-in)	Hand-tight	
		Quantity	–	3	
J	Screw for Protector Cap	Wrench size	mm	8	
		Tightening torque	Nm (lbf-in)	3.5 (31)	
		Quantity	–	48	
K ⁽¹⁾	Clamping screw gearbox rotational axis	Wrench size	mm	3	
		Tightening torque	Nm (lbf-in)	4.5 (40)	
		Quantity	–	1	
L ⁽¹⁾	Screw gearbox rotational axis to housing	Wrench size	mm	8	
		Tightening torque	Nm (lbf-in)	3.5 (31)	
		Quantity	–	4	

(1) For robots with a rotational axis.

(2) Medium threadlocked with Loctite 243.

Dimension	Description	Unit	VRKP0S0-WF	VRKP4S0-WF	VRKP5S0-WF	
			VRKP1S0-WF		VRKP6S0-WF	
A	Width A	mm (in)	667 (26)	959 (38)	1078 (42)	
B	Width B	mm (in)	698 (27.5)	1033 (41)	1187 (47)	
C	Height C	mm (in)	331 (13)	356 (14)	356 (14)	
D	Height D	mm (in)	2 (0.08)	6 (0.2)	6 (0.2)	
D*(1)	Height D*	mm (in)	57 (2.24)	61 (2.4)	61 (2.4)	
E	Clamping screw gearbox main axis	Wrench size	mm	3	4	4
		Tightening torque	Nm (lbf-in)	4.1 (36)	9.5 (84)	9.5 (84)
		Quantity	–	3		
F	Screw gearbox main axis to housing	Wrench size	mm	3	4	4
		Tightening torque	Nm (lbf-in)	3 (26.6)	4.7 (42)	4.7 (42)
		Quantity	–	24	48	48
G	Screw motor to gearbox(2)	Wrench size	mm	4		
		Tightening torque	Nm (lbf-in)	3.5 (31)		
		Quantity	–	12 or 16(1)		
H	Hex nut grounding cable motor	Wrench size	mm	7		
		Tightening torque	Nm (lbf-in)	2.5 (22)		
		Quantity	–	3 or 4(1)		
I	Indexing bolt upper arm(2)	Wrench size	mm	2.5	3	3
		Tightening torque	Nm (lbf-in)	Hand-tight		
		Quantity	–	3		
J	Screw for Protector Cap	Wrench size	mm	7	8	8
		Tightening torque	Nm (lbf-in)	2 (17.7)	3.5 (31)	3.5 (31)
		Quantity	–	24	48	48
K	Screw media cover	Wrench size	mm	10		
		Tightening torque	Nm (lbf-in)	6 (53)		
		Quantity	–	5		
L	Screw cover rotational axis	Wrench size	mm	8		
		Tightening torque	Nm (lbf-in)	3.5 (31)		
		Quantity	–	4		
L*(1)	Screw gearbox rotational axis to housing	Wrench size	mm	8		
		Tightening torque	Nm (lbf-in)	3.5 (31)		
		Quantity	–	4		
M	Threaded rod motor cover	Wrench size	mm	10		
		Tightening torque	Nm (lbf-in)	6 (53)		
		Quantity	–	12		

Dimension	Description	Unit	VRKP0S0-WF	VRKP4S0-WF		VRKP5S0-WF
			VRKP1S0-WF			VRKP6S0-WF
N*(1)	Clamping screw gearbox rotational axis	Wrench size	mm	3		
		Tightening torque	Nm (lbf-in)	4.5 (40)		
		Quantity	-	1		
O	Cable gland M50 for motor/encoder cable	Wrench size	mm	56		
		Tightening torque	Nm (lbf-in)	10 (89)		
		Quantity	-	2 or 4(1)	2	2
P	Cable gland M16 for grounding cable/fan cable	Wrench size	mm	19		
		Tightening torque	Nm (lbf-in)	6 (53)		
		Quantity	-	2 or 4(1)	2	2
(1) For robots with a rotational axis.						
(2) Medium threadlocked with Loctite 243.						

Dimension	Description	Unit	VRKP2S0-WD	VRKP4S0-WD
				VRKP4S0-CW
A	Width A	mm (in)	959 (38)	
B	Width B	mm (in)	966 (38)	1033 (41)
C	Height C	mm (in)	556 (22)	
D	Height D	mm (in)	30 (1.18)	
E	Clamping screw gearbox main axis	Wrench size	mm	4
		Tightening torque	Nm (lbf-in)	9.5 (84)
		Quantity	–	3
F	Screw gearbox main axis to housing	Wrench size	mm	4
		Tightening torque	Nm (lbf-in)	4.7 (42)
		Quantity	–	48
G	Screw motor to gearbox ⁽²⁾	Wrench size	mm	4
		Tightening torque	Nm (lbf-in)	3.5 (31)
		Quantity	–	12 or 16 ⁽¹⁾
H	Hex nut grounding cable motor	Wrench size	mm	7
		Tightening torque	Nm (lbf-in)	2.5 (22)
		Quantity	–	3 or 4 ⁽¹⁾
I	Indexing bolt upper arm ⁽²⁾	Wrench size	mm	3
		Tightening torque	Nm (lbf-in)	Hand-tight
		Quantity	–	3
J	Screw for Protector Cap	Wrench size	mm	8
		Tightening torque	Nm (lbf-in)	3.5 (31)
		Quantity	–	48
K	Screw media cover / maintenance cover	Wrench size	mm	10
		Tightening torque	Nm (lbf-in)	6 (53)
		Quantity	–	57
L	Screw cover rotational axis	Wrench size	mm	8
		Tightening torque	Nm (lbf-in)	3.5 (31)
		Quantity	–	4
L ^{*(1)}	Screw gearbox rotational axis to housing	Wrench size	mm	8
		Tightening torque	Nm (lbf-in)	3.5 (31)
		Quantity	–	4
M	Threaded rod motor cover	Wrench size	mm	10
		Tightening torque	Nm (lbf-in)	6 (53)
		Quantity	–	12
N	Cable gland M16 for grounding cable	Wrench size	mm	19
		Tightening torque	Nm (lbf-in)	6 (53)
		Quantity	–	1
O	Cable gland M50 for motor / encoder cable	Wrench size	mm	56
		Tightening torque	Nm (lbf-in)	10 (89)
		Quantity	–	2

Dimension	Description		Unit	VRKP2S0•WD	VRKP4S0•WD VRKP4S0•CW
P*(1)	Clamping screw gearbox rotational axis	Wrench size	mm	3	
		Tightening torque	Nm (lbf-in)	4.5 (40)	
		Quantity	–	1	
<p>(1) For robots with a rotational axis.</p> <p>(2) Medium threadlocked with Loctite 243.</p>					

Dimension	Description	Unit	VRKP4L0-WD VRKP4L0-NO	
A	Width A	mm (in)	959 (38)	
B	Width B	mm (in)	1033 (41)	
C	Height C	mm (in)	556 (22)	
D	Clamping screw gearbox main axis	Wrench size	mm	4
		Tightening torque	Nm (lbf-in)	9.5 (84)
		Quantity	–	3
E	Screw gearbox main axis to housing	Wrench size	mm	4
		Tightening torque	Nm (lbf-in)	4.7 (42)
		Quantity	–	48
F	Screw motor to gearbox ⁽²⁾	Wrench size	mm	4
		Tightening torque	Nm (lbf-in)	3.5 (31)
		Quantity	–	12 or 16 ⁽¹⁾
G	Hex nut grounding cable motor	Wrench size	mm	7
		Tightening torque	Nm (lbf-in)	2.5 (22)
		Quantity	–	3 or 4 ⁽¹⁾
H	Indexing bolt upper arm ⁽²⁾	Wrench size	mm	3
		Tightening torque	Nm (lbf-in)	Hand-tight
		Quantity	–	3
I	Screw for Protector Cap	Wrench size	mm	8
		Tightening torque	Nm (lbf-in)	3.5 (31)
		Quantity	–	48
J	Screw media cover / maintenance cover	Wrench size	mm	10
		Tightening torque	Nm (lbf-in)	6 (53)
		Quantity	–	57
K	Screw cover rotational axis	Wrench size	mm	8
		Tightening torque	Nm (lbf-in)	3.5 (31)
		Quantity	–	4
K ^{*(1)}	Screw gearbox rotational axis to housing	Wrench size	mm	8
		Tightening torque	Nm (lbf-in)	3.5 (31)
		Quantity	–	4
L	Threaded rod motor cover	Wrench size	mm	10
		Tightening torque	Nm (lbf-in)	6 (53)
		Quantity	–	12
M	Fixing bolt ILM Distribution Box	Wrench size	mm	8
		Tightening torque	Nm (lbf-in)	3.5 (31)
		Quantity	–	4
N ^{*(1)}	Clamping screw gearbox rotational axis	Wrench size	mm	3
		Tightening torque	Nm (lbf-in)	4.5 (40)
		Quantity	–	1

(1) For robots with a rotational axis.
(2) Medium threadlocked with Loctite 243.

Dimension	Description	Unit	Robot type					
			VRKP0	VRKP1	VRKP2	VRKP4	VRKP5	VRKP6
A	Adjustment value for controller	mm (in)	180 (7.1)	230 (9)	280 (112)	380 (15)	430 (17)	480 (19)
B	Total length	mm (in)	206.9 (8.1)	257.1 (10.1)	319 (13)	419.4 (16.5)	469.5 (18.5)	519.6 (20.5)
C	Flange diameter	mm (in)	40 (1.57)	40 (1.57)	65 (2.56)	65 (2.56)	65 (2.56)	65 (2.56)
D	Flange center distance	mm (in)	25 (0.98)	25 (0.98)	35 (1.38)	35 (1.38)	35 (1.38)	35 (1.38)

Detail Drawing of the Lower Arm

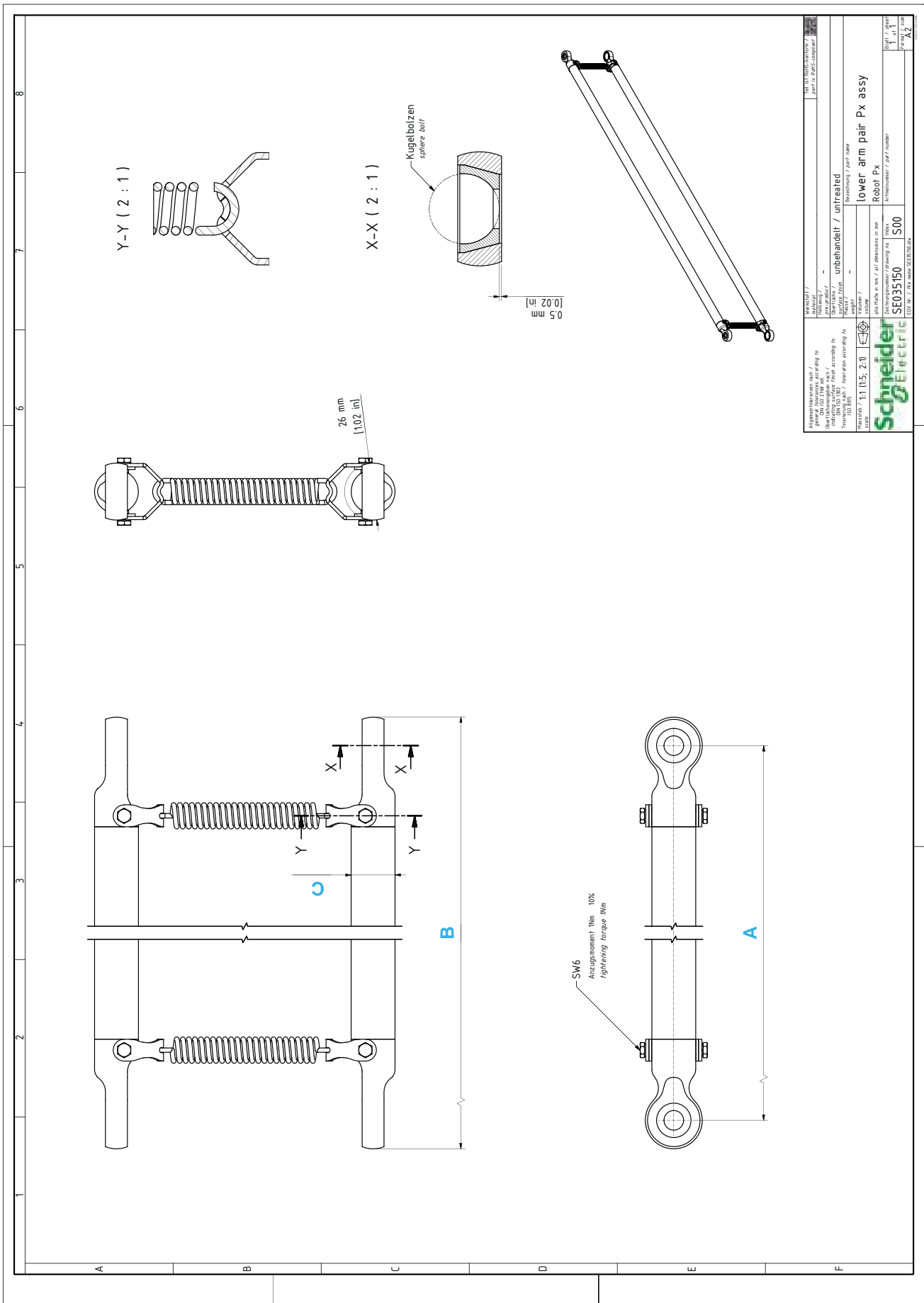

Dimension	Description	Unit	Robot type								
			VRKP0	VRK-P-0.....-E00	VRKP1	VRK-P-1.....-E00	VRKP2	VRKP4	VRKP5	VRKP6	VRK-P-6.....-E00
A	Adjustment value for controller	mm (in)	400 (15.7)	500 (19.7)	500 (19.7)	600 (23.6)	600 (23.6)	900 (35.4)	1050 (41)	1150 (45)	1270 (50)
B	Total length	mm (in)	426 (16.8)	526 (20.7)	526 (20.7)	626 (24.6)	626 (24.6)	926 (36.5)	1076 (42.4)	1176 (46)	1296 (51)
C	Tube diameter	mm (in)	16 (0.63)	16 (0.63)	16 (0.63)	20 (0.79)	20 (0.79)	20 (0.79)	20 (0.79)	20 (0.79)	20 (0.79)

Dimension	Description	Unit	Robot type								
			VRKP0	VRK-P-0.....-E00	VRKP1	VRK-P-1.....-E00	VRKP2	VRKP4	VRKP5	VRKP6	VRK-P-6.....-E00
A	Minimum length	mm (in)	326.8 (12.9)	381.8 (15)	390.2 (15.4)	444 (17.5)	458.4 (18)	610.4 (24)	686.4 (27)	766.4 (30.2)	842.4 (33)
B	Stroke	mm (in)	147 (5.8)	202 (8)	210.4 (8.3)	264.2 (10.4)	278.6 (11)	430.6 (17)	506.6 (20)	586.6 (23)	662.6 (26)

Electrical Connections

Electrical Connections

Electrical Connections of Lexium P Robots with SH3 Motors (VRKP•S)

Connection power P30 (size 1): Connection power, brake, and temperature sensor

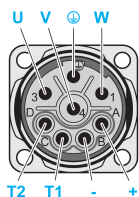
Representation	Pin	Designation	Meaning	Range
	1	W	Performance	3 x 0...480 Vac
	2	PE	Protective ground (earth) cable	–
	3	U	Performance	3 x 0...480 Vac
	4	V	Performance	3 x 0...480 Vac
	A	+	Brake	24 Vdc
	B	-	Brake	0 Vdc
	C	T1	Temperature sensor	–
	D	T2	Temperature sensor	–

Encoder Connection: Encoder SKS/SKM-36

Representation	Pin	Designation	Meaning	Range
	1	REF COS	Reference signal Cosinus	–
	2	RS 485 +	Parameter channel +	–
	3	–	–	–
	4	–	–	–
	5	SIN	Sinusoidal trace	–
	6	REF SIN	Reference signal sine	–
	7	RS 485 -	Parameter channel -	–
	8	COS	Cosine track	–
	9	–	–	–
	10	0 V	Supply Voltage	DC 0 V
	11	–	–	–
	12	U _s	Supply Voltage	DC 7...12 V

Electrical Connections of Lexium P Robots with ILM Motors (VRKP•L0)

Connector Lexium 62 ILM Servo Module

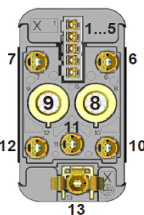
Representa- tion	Pin	Designation	Meaning
	1	IE_sig	Inverter Enable (differential signal)
	2	IE_ref	
	3	Brake	Braking signal
	4	N.C.	Not connected
	5	N.C.	Not connected
	6	0 V	Control voltage 0 V
	7	24 V	Control voltage 24 V
	8.1	Rx+	Sercos port 1 - Input (not assigned for daisy chain wiring)
	8.2	Tx-	Sercos port 1 - Output (not assigned for daisy chain wiring)
	8.3	Rx-	Sercos port 1 - Input (not assigned for daisy chain wiring)
	8.4	Tx+	Sercos port 1 - Output (not assigned for daisy chain wiring)
	9.1	Rx+	Sercos port 2 - Input (not assigned for daisy chain wiring)
	9.2	Tx-	Sercos port 2 - Output (not assigned for daisy chain wiring)
	9.3	Rx-	Sercos port 2 - Input (not assigned for daisy chain wiring)
	9.4	Tx+	Sercos port 2 - Output (not assigned for daisy chain wiring)
	10	DC -	DC bus voltage -
	11	Shield	Shielded connector
12	DC +	DC bus voltage +	
13	PE	Protective ground (earth) cable	

Fan Connections (Only for VRKP2S0•WD / VRKP4L0•WD / VRKP4L0•NO / VRKP4S0•WF / VRKP5S0•WF / VRKP6S0•WF)

Pin	Designation	Meaning
1	0 Vdc	Fan - supply voltage
2	24 Vdc	Fan + supply voltage

NOTE: For each fan, 260 mA are required, that is, 3x 260 mA are required for each robot.

Performance Data

Typical Cycle Time

Robot Path (pick-place-pick):

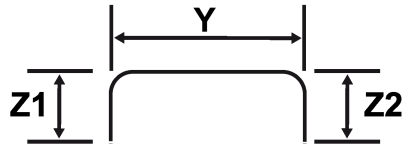

Cycle Times of Robot VRKP0

The following measurements are performed at an ambient temperature of 20 °C (68 °F) with a PacDrive 3 and use the SchneiderElectricRobotics library.

Path Z1 x Y x Z2 in mm (in)	Load [kg (lb)]	Cycle times [s] ⁽¹⁾	Cycles per minute
15 x 200 x 15 (0.59 x 7.9 x 0.59)	0.1 (0.22)	0.24	250
	0.5 (1.1)	0.258	232
	1.0 (2.2)	0.276	217
	1.5 (3.3)	0.305	197
	3.0 (6.6)	0.355	169
	5.0 (11)	0.424	141
	7.0 (15.4)	0.515	117
	10.0 (22)	0.593	101
25 x 305 x 25 (0.98 x 12 x 0.98)	0.1 (0.22)	0.297	202
	0.5 (1.1)	0.327	184
	1.0 (2.2)	0.348	173
	1.5 (3.3)	0.376	160
	3.0 (6.6)	0.455	132
	5.0 (11)	0.528	114
	7.0 (15.4)	0.628	96
	10.0 (22)	0.695	86

(1) Cycle times contain the back and forth motion. A position is considered as reached when the robot remains permanently in a window of +/-0.25 mm (0.0098 in) around the target position.

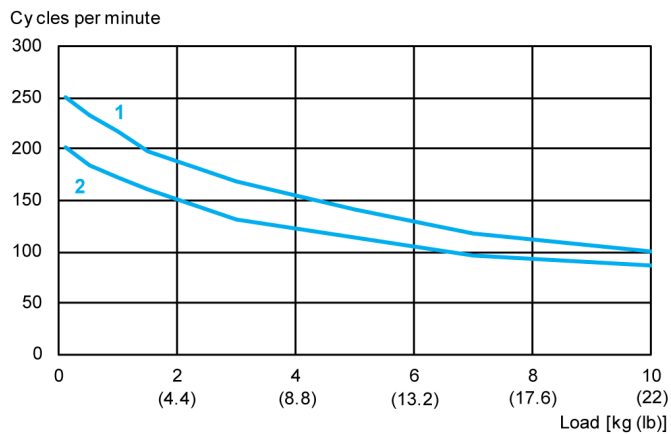

1 15 x 200 x 15 mm (0.59 x 7.9 x 0.59 in)

2 25 x 305 x 25 mm (0.98 x 12 x 0.98 in)

Cycle Times of Robot VRKP0.....E00

The following measurements are performed at an ambient temperature of 20 °C (68 °F) with a PacDrive 3 and use the SchneiderElectricRobotics library.

Path Z1 x Y x Z2 in mm (in)	Load [kg (lb)]	Cycle times [s] ⁽¹⁾	Cycles per minute
15 x 200 x 15 (0.59 x 7.9 x 0.59)	0.1 (0.22)	0.246	244
	0.5 (1.1)	0.275	218
	1.0 (2.2)	0.290	207
	1.5 (3.3)	0.312	192
	3.0 (6.6)	0.364	165
	5.0 (11)	0.439	137
	7.0 (15.4)	0.538	112
	10.0 (22)	0.595	101
25 x 305 x 25 (0.98 x 12 x 0.98)	0.1 (0.22)	0.302	198
	0.5 (1.1)	0.340	176
	1.0 (2.2)	0.356	169
	1.5 (3.3)	0.380	158
	3.0 (6.6)	0.464	129
	5.0 (11)	0.548	109
	7.0 (15.4)	0.631	95
	10.0 (22)	0.695	86

(1) Cycle times contain the back and forth motion. A position is considered as reached when the robot remains permanently in a window of +/-0.25 mm (0.0098 in) around the target position.

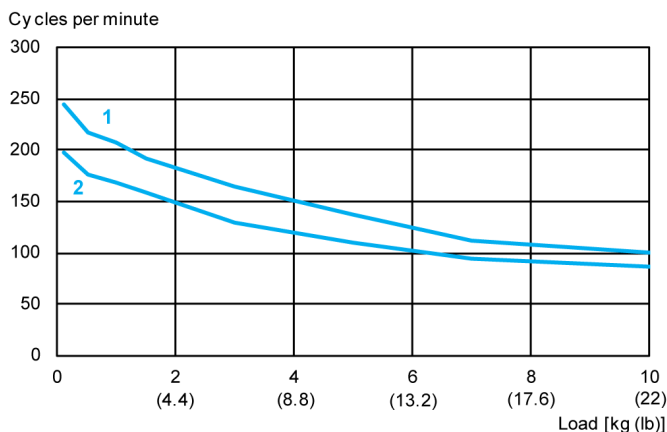

1 15 x 200 x 15 mm (0.59 x 7.9 x 0.59 in)

2 25 x 305 x 25 mm (0.98 x 12 x 0.98 in)

Cycle Times of Robot VRKP1

The following measurements are performed at an ambient temperature of 20 °C (68 °F) with a PacDrive 3 and use the SchneiderElectricRobotics library.

Path Z1 x Y x Z2 in mm (in)	Load [kg (lb)]	Cycle times [s] ⁽¹⁾	Cycles per minute
15 x 200 x 15 (0.59 x 7.9 x 0.59)	0.1 (0.22)	0.258	232
	0.5 (1.1)	0.290	207
	1.0 (2.2)	0.313	192
	1.5 (3.3)	0.340	176
	3.0 (6.6)	0.405	148
	5.0 (11)	0.483	124
	7.0 (15.4)	0.607	99
	10.0 (22)	0.708	85
25 x 305 x 25 (0.98 x 12 x 0.98)	0.1 (0.22)	0.313	192
	0.5 (1.1)	0.352	171
	1.0 (2.2)	0.397	151
	1.5 (3.3)	0.426	141
	3.0 (6.6)	0.502	120
	5.0 (11)	0.618	97
	7.0 (15.4)	0.732	82
	10.0 (22)	0.817	73
70 x 400 x 70 (2.76 x 15.7 x 2.76)	0.1 (0.22)	0.396	152
	0.5 (1.1)	0.447	134
	1.0 (2.2)	0.470	128
	1.5 (3.3)	0.503	119
	3.0 (6.6)	0.592	101
	5.0 (11)	0.719	83
	7.0 (15.4)	0.825	73
	10.0 (22)	0.964	62

(1) Cycle times contain the back and forth motion. A position is considered as reached when the robot remains permanently in a window of +/-0.25 mm (0.0098 in) around the target position.

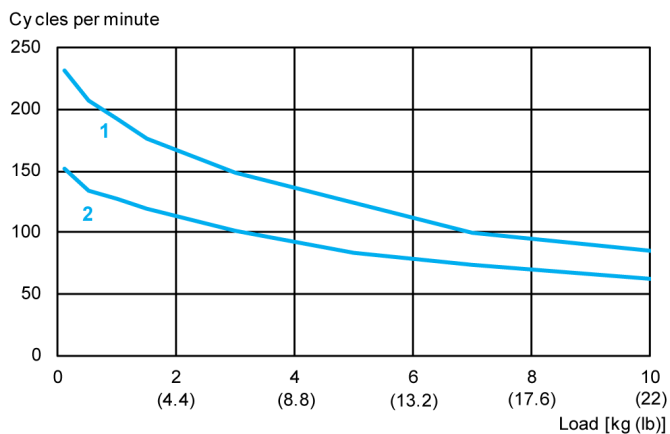

1 15 x 200 x 15 mm (0.59 x 7.9 x 0.59 in)

2 70 x 400 x 70 mm (2.76 x 15.7 x 2.76 in)

Cycle Times of Robot VRKP1.....E00

The following measurements are performed at an ambient temperature of 20 °C (68 °F) with a PacDrive 3 and use the SchneiderElectricRobotics library.

Path Z1 x Y x Z2 in mm (in)	Load [kg (lb)]	Cycle times [s] ⁽¹⁾	Cycles per minute
15 x 200 x 15 (0.59 x 7.9 x 0.59)	0.1 (0.22)	0.269	223
	0.5 (1.1)	0.306	196
	1.0 (2.2)	0.330	182
	1.5 (3.3)	0.400	150
	3.0 (6.6)	0.422	142
	5.0 (11)	0.505	119
	7.0 (15.4)	0.616	97
	10.0 (22)	0.719	83
25 x 305 x 25 (0.98 x 12 x 0.98)	0.1 (0.22)	0.329	183
	0.5 (1.1)	0.385	156
	1.0 (2.2)	0.426	141
	1.5 (3.3)	0.444	135
	3.0 (6.6)	0.532	113
	5.0 (11)	0.629	95
	7.0 (15.4)	0.741	81
	10.0 (22)	0.841	71
70 x 400 x 70 (2.76 x 15.7 x 2.76)	0.1 (0.22)	0.423	142
	0.5 (1.1)	0.469	128
	1.0 (2.2)	0.498	121
	1.5 (3.3)	0.536	112
	3.0 (6.6)	0.644	93
	5.0 (11)	0.775	77
	7.0 (15.4)	0.845	71
	10.0 (22)	1.019	59

(1) Cycle times contain the back and forth motion. A position is considered as reached when the robot remains permanently in a window of +/-0.25 mm (0.0098 in) around the target position.

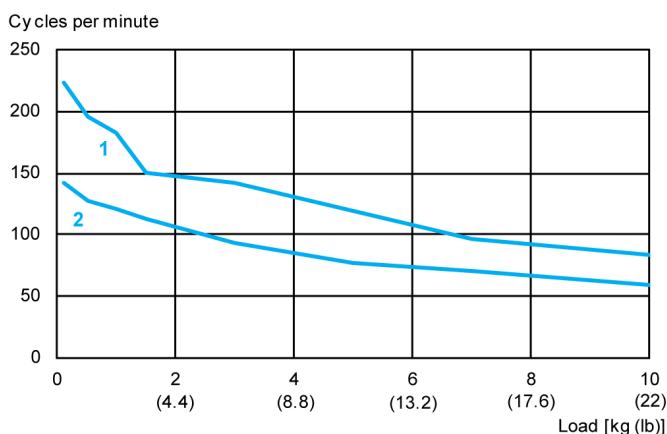

1 15 x 200 x 15 mm (0.59 x 7.9 x 0.59 in)

2 70 x 400 x 70 mm (2.76 x 15.7 x 2.76 in)

Cycle Times of Robot VRKP2

The following measurements are performed at an ambient temperature of 20 °C (68 °F) with a PacDrive 3 and use the SchneiderElectricRobotics library.

Path Z1 x Y x Z2 in mm (in)	Load [kg (lb)]	Cycle times [s] ⁽¹⁾	Cycles per minute
25 x 305 x 25 (0.98 x 12 x 0.98)	0.1 (0.22)	0.24	250
	0.5 (1.1)	0.252	238
	1.0 (2.2)	0.287	209
	1.5 (3.3)	0.333	180
	3.0 (6.6)	0.396	152
	5.0 (11)	0.464	129
	7.0 (15.4)	0.56	107
	10.0 (22)	0.665	90
	15.0 (33)	0.801	75
70 x 400 x 70 (2.76 x 15.7 x 2.76)	0.1 (0.22)	0.32	188
	0.5 (1.1)	0.35	171
	1.0 (2.2)	0.369	163
	1.5 (3.3)	0.39	154
	3.0 (6.6)	0.473	127
	5.0 (11)	0.556	108
	7.0 (15.4)	0.652	92
	10.0 (22)	0.743	81
	15.0 (33)	0.853	70

(1) Cycle times contain the back and forth motion. A position is considered as reached when the robot remains permanently in a window of +/-0.25 mm (0.0098 in) around the target position.

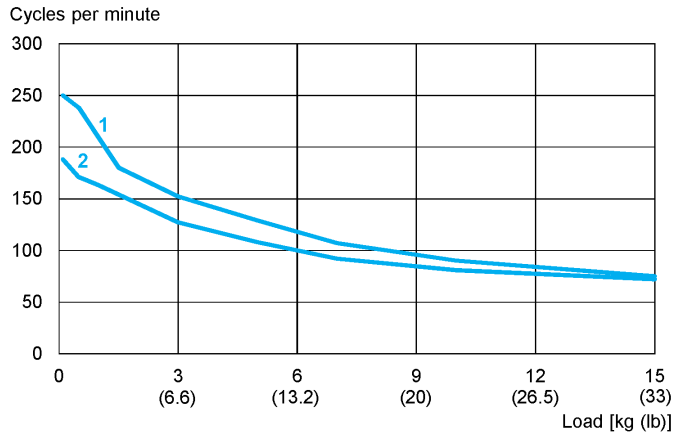

1 25 x 305 x 25 mm (0.98 x 12 x 0.98 in)

2 70 x 400 x 70 mm (2.76 x 15.7 x 2.76 in)

Cycle Times of Robot VRKP4

The following measurements are performed at an ambient temperature of 20 °C (68 °F) with a PacDrive 3 and use the SchneiderElectricRobotics library.

Path Z1 x Y x Z2 in mm (in)	Load [kg (lb)]	Cycle times [s] ⁽¹⁾	Cycles per minute
25 x 305 x 25 (0.98 x 12 x 0.98)	0.1 (0.22)	0.288	208
	0.5 (1.1)	0.32	188
	1.0 (2.2)	0.325	185
	1.5 (3.3)	0.355	169
	3.0 (6.6)	0.424	142
	5.0 (11)	0.497	121
	7.0 (15.4)	0.537	112
	10.0 (22)	0.659	91
	15.0 (33)	0.924	65
70 x 400 x 70 (2.76 x 15.7 x 2.76)	0.1 (0.22)	0.325	185
	0.5 (1.1)	0.362	166
	1.0 (2.2)	0.375	160
	1.5 (3.3)	0.401	150
	3.0 (6.6)	0.471	127
	5.0 (11)	0.557	108
	7.0 (15.4)	0.617	97
	10.0 (22)	0.701	86
	15.0 (33)	0.985	61
90 x 700 x 90 (3.54 x 27.6 x 3.54)	0.1 (0.22)	0.418	144
	0.5 (1.1)	0.444	135
	1.0 (2.2)	0.469	128
	1.5 (3.3)	0.506	119
	3.0 (6.6)	0.607	99
	5.0 (11)	0.713	84
	7.0 (15.4)	0.803	75
	10.0 (22)	0.925	65
	15.0 (33)	1.223	49

(1) Cycle times contain the back and forth motion. A position is considered as reached when the robot remains permanently in a window of +/-0.25 mm (0.0098 in) around the target position.

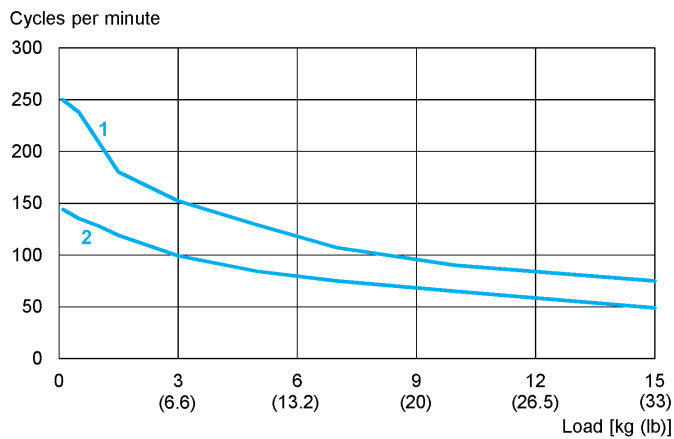

1 25 x 305 x 25 mm (0.98 x 12 x 0.98 in)

2 90 x 700 x 90 mm (3.54 x 27.6 x 3.54 in)

Cycle Times of Robot VRKP5

The following measurements are performed at an ambient temperature of 20 °C (68 °F) with a PacDrive 3 and use the SchneiderElectricRobotics library.

Path Z1 x Y x Z2 in mm (in)	Load [kg (lb)]	Cycle times [s] ⁽¹⁾	Cycles per minute
25 x 305 x 25 (0.98 x 12 x 0.98)	0.1 (0.22)	0.292	205
	0.5 (1.1)	0.330	182
	1.0 (2.2)	0.362	166
	1.5 (3.3)	0.374	160
	3.0 (6.6)	0.466	129
	5.0 (11)	0.520	115
	7.0 (15.4)	0.584	103
	10.0 (22)	0.668	90
	15.0 (33)	0.754	80
70 x 400 x 70 (2.76 x 15.7 x 2.76)	0.1 (0.22)	0.340	176
	0.5 (1.1)	0.366	164
	1.0 (2.2)	0.400	150
	1.5 (3.3)	0.420	143
	3.0 (6.6)	0.490	122
	5.0 (11)	0.584	103
	7.0 (15.4)	0.622	97
	10.0 (22)	0.732	82
	15.0 (33)	0.926	65
90 x 700 x 90 (3.54 x 27.6 x 3.54)	0.1 (0.22)	0.438	137
	0.5 (1.1)	0.472	127
	1.0 (2.2)	0.518	116
	1.5 (3.3)	0.530	113
	3.0 (6.6)	0.632	95
	5.0 (11)	0.750	80
	7.0 (15.4)	0.843	71
	10.0 (22)	0.956	63
	15.0 (33)	1.102	54

(1) Cycle times contain the back and forth motion. A position is considered as reached when the robot remains permanently in a window of +/-0.25 mm (0.0098 in) around the target position.

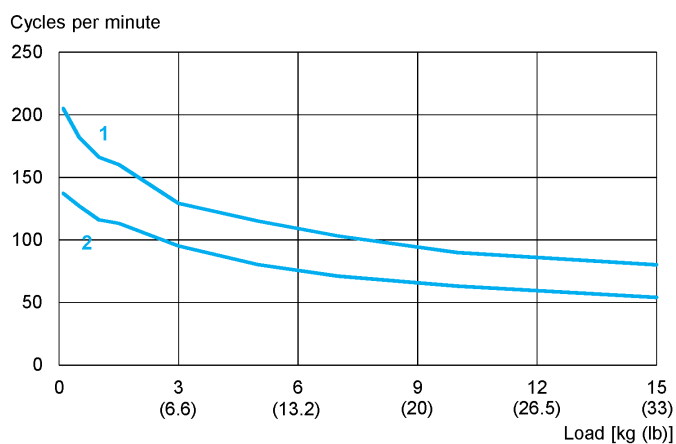

- 1 25 x 305 x 25 mm (0.98 x 12 x 0.98 in)
- 2 90 x 700 x 90 mm (3.54 x 27.6 x 3.54 in)

Cycle Times of Robot VRKP6

The following measurements are performed at an ambient temperature of 20 °C (68 °F) with a PacDrive 3 and use the SchneiderElectricRobotics library.

Path Z1 x Y x Z2 in mm (in)	Load [kg (lb)]	Cycle times [s] ⁽¹⁾	Cycles per minute
25 x 305 x 25 (0.98 x 12 x 0.98)	0.1 (0.22)	0.333	180
	0.5 (1.1)	0.368	163
	1.0 (2.2)	0.405	148
	1.5 (3.3)	0.465	129
	3.0 (6.6)	0.499	120
	5.0 (11)	0.545	110
	7.0 (15.4)	0.595	101
	10.0 (22)	0.695	86
	15.0 (33) ⁽²⁾	0.785	76
70 x 400 x 70 (2.76 x 15.7 x 2.76)	0.1 (0.22)	0.375	160
	0.5 (1.1)	0.400	150
	1.0 (2.2)	0.432	139
	1.5 (3.3)	0.449	134
	3.0 (6.6)	0.512	117
	5.0 (11)	0.595	101
	7.0 (15.4)	0.724	83
	10.0 (22)	0.811	74
	15.0 (33) ⁽²⁾	0.986	61
90 x 700 x 90 (3.54 x 27.6 x 3.54)	0.1 (0.22)	0.509	118
	0.5 (1.1)	0.523	115
	1.0 (2.2)	0.564	106
	1.5 (3.3)	0.583	103
	3.0 (6.6)	0.707	85
	5.0 (11)	0.799	75
	7.0 (15.4)	0.899	67
	10.0 (22)	0.985	61
	15.0 (33) ⁽²⁾	1.274	47
110 x 1300 x 110 (4.3 x 51 x 4.3)	0.1 (0.22)	0.685	88
	0.5 (1.1)	0.749	80
	1.0 (2.2)	0.819	73
	1.5 (3.3)	0.835	72
	3.0 (6.6)	0.963	62
	5.0 (11)	1.170	51
	7.0 (15.4)	1.314	46
	10.0 (22)	1.436	42
	15.0 (33) ⁽²⁾	2.250	27

Path Z1 x Y x Z2 in mm (in)	Load [kg (lb)]	Cycle times [s] ⁽¹⁾	Cycles per minute
(1) Cycle times contain the back and forth motion. A position is considered as reached when the robot remains permanently in a window of +/-0.25 mm (0.0098 in) around the target position.			
(2) Loads up to 10 kg (22 lb). Heavier payloads of up to 15 kg (33 lb) upon request. If required, contact your local Schneider Electric service representative.			

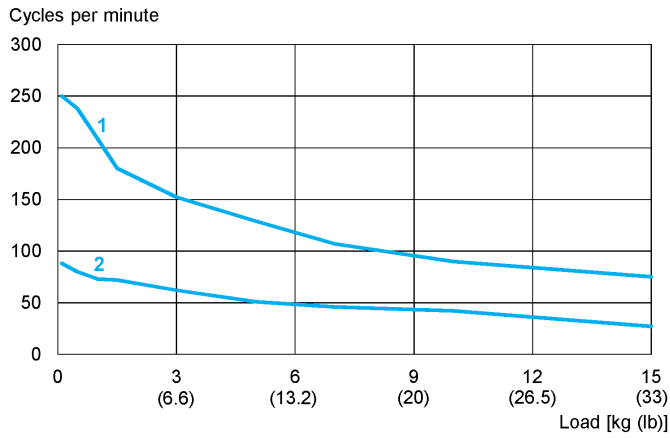

1 25 x 305 x 25 mm (0.98 x 12 x 0.98 in)

2 110 x 1300 x 110 mm (4.3 x 51 x 4.3 in)

Load Capacity Diagram

Overview

The two load diagrams show the maximum permissible distance of the mass center of gravity from the Flange Center Point (FCP) for a given acceleration relative to the mass. For detailed information, refer to the respective dimensional drawing in *Mechanical and Electrical Data*, page 31.

The limit values for the maximum tilting torque must always be complied with.

Maximum Tilting Torque (Vertical Distance From the FCP)

The loading capacity of the Lexium P robots is limited by the maximum tilting torque at the FCP. The following diagram shows the possible vertical distance of the mass center of gravity of the payload relative to the mass and the required maximum acceleration.

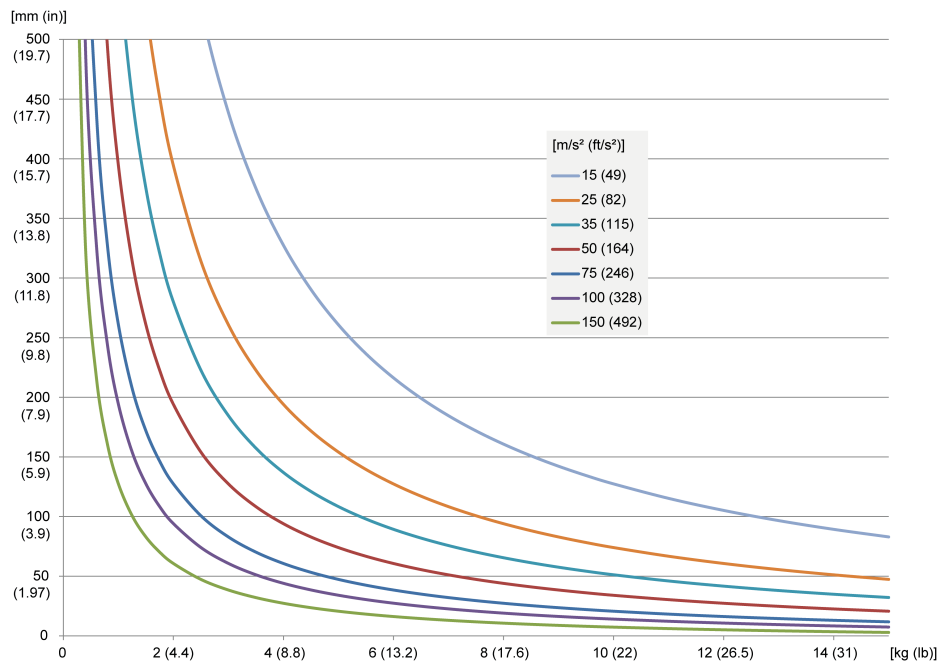

A maximum tilting torque of 20 Nm (177 lbf-in) is to be observed at the FCP.

Calculate the tilting torque with the following formula:

$$\text{Tilting torque [Nm (lbf-in)]} = \text{payload [kg (lb)]} \times \text{maximum acceleration [m/s}^2 \text{ (ft/s}^2\text{)]} \times (\text{vertical distance from the FCP [m (in)]} + 0.006 \text{ m (0.236 in)})$$

Positioning Performance

Overview

The following diagrams specify the performance of the telescopic axis and show that, in addition to the movement time, the rotation of the axis also requires time. In many applications the rotation of the rotational axis is the limiting element. An observation of its performance is inevitable for the layout of an application.

The diagrams show the movement time (Y2-axis), that is, the time required by the telescopic axis in order to rotate forward and backward by the specified angle.

The specified moment of inertia (X-axis) refers to the sum of the moments of inertia of the gripper and the customer end product. The inertia of the axis is already comprised in the diagram.

NOTE: When using the `SchneiderElectricRobotics` library the performance of the rotational axis is adapted automatically; specifying or determining the moments of inertia is not required.

Positioning Performance of the Telescopic Axes

The following graph presents the positioning performance of the telescopic axes of the Lexium P robots when the center of gravity of the gripper and the customer end product is located centrally under the telescopic axis (lateral displacement = 0).

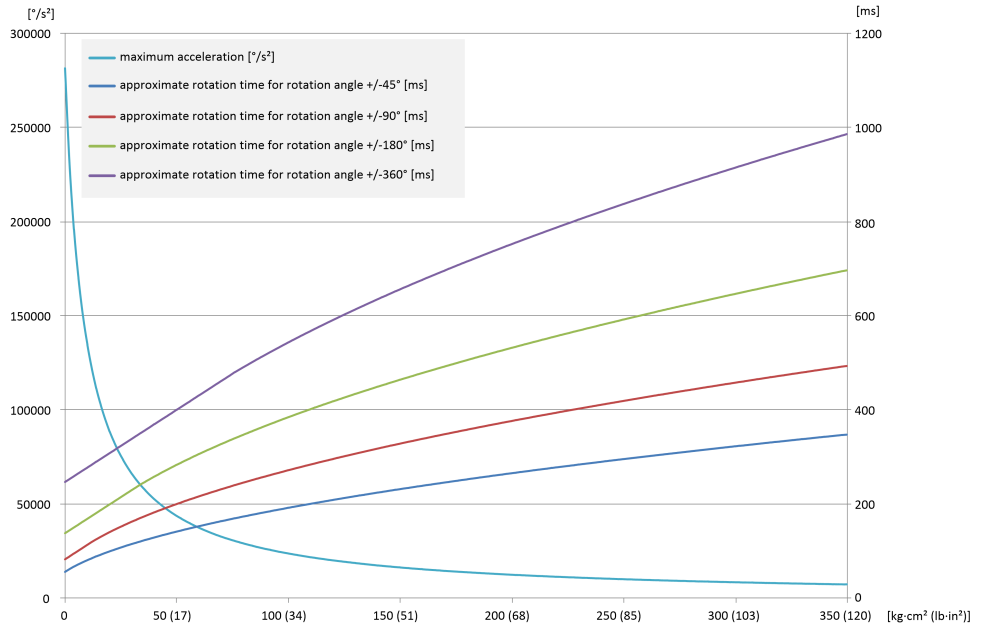

Design of the Robot Frame

Design of the Robot Frame

System Requirements

Use the Lexium P robot for ceiling mounting. For special applications with an angularly suspended robot system, contact your local Schneider Electric service representative.

- Delta-3 robot of the Lexium P reach their highest level of performance and accuracy in the center of the working space.
- Position the robot to locate the movements to be executed as closely as possible to the center of the working space.
- When determining the suspension height of the robot, observe the overall height of the gripper (suction cup or other product pickups).
- For the design of the robot frame, account for possible varying gripper heights. Design the robot suspension in a height-adjustable manner.

The precision of the robot in the application is also determined by the frame. Deformations of the frame cause imprecisions on the Tool Center Point (TCP).

General Requirements Regarding the Frame

The frame must not only withstand the constant forces and torques stated below, but also have sufficient stiffness so that the deformations and vibrations which occur do not lead to any major deviations on the TCP. Ensure a sufficient transverse bracing in the frame.

Note the forces and torques to be taken up by the frame during normal operation:

Parameter	Value
Static load	approximately 1.2 kN (270 lbf)
Dynamic load	approximately 1.4 kN (315 lbf) in any direction
Dynamic torque	approximately 2000 Nm (17701 lbf-in)

Fasten the robot with three screws of property class 8.8 or greater, or A2-70 or greater.

For further information, refer to the respective dimensional drawing in *Mechanical and Electrical Data*, page 31.

NOTE: The configuration of the robot mechanics, the TCP velocity, as well as the additional payload have an effect on the total energy, which can potentially cause damage.

⚠ WARNING
CRUSHING, SHEARING, CUTTING AND IMPACT INJURY
<ul style="list-style-type: none"> • The robot must be operated only within an enclosure. • Open or enter the enclosure for cleaning and maintenance purposes only. • Design the enclosure to withstand an impact from the robot and to resist ejected parts from escaping the zone of operation. • Design the enclosure to safely deactivate the robot as soon as a person enters the zone of operation of the robot. • All barriers, protective doors, contact mats, light barriers, and other protective equipment, must be configured correctly and enabled whenever the robot mechanics are under power. • Define the clearance distance to the zone of operation of the robot so the operational staff do not have access to, nor can be enclosed in, the robot mechanics zone of operation. • Design the enclosure to account for the maximum possible travel paths of the robot; that is, the maximum path until the hardware safety system limits as well as the additional run-on paths, in case of a power interruption. <p>Failure to follow these instructions can result in death, serious injury, or equipment damage.</p>

For further information about travel path and power loss, refer to *Run-on Motions of the Robot for Risk Analysis*, page 94.

Interference Contours in the Enclosure

When designing the enclosure, ensure that the upper and lower arms of the robot will have sufficient freedom of movement. Take into account the required space for the movement of the respective robot type and associated equipment.

The following table presents the type of the mounting surface and space in which the robot must be operated.

Robot type	Type of mounting surface and space
VRKP0***WF	On a closed mounting surface (except for the mounting holes and the cable gland).
VRKP0***NC	On a mounting surface with open spaces.
VRKP0***WF**E00	On a closed mounting surface (except for the mounting holes and the cable gland).
VRKP0***NC**E00	On a mounting surface with open spaces.
VRKP1***WF	On a closed mounting surface (except for the mounting holes and the cable gland).
VRKP1***NC	On a mounting surface with open spaces.

Robot type	Type of mounting surface and space
VRKP1•••WF••E00	On a closed mounting surface (except for the mounting holes and the cable gland).
VRKP1•••NC••E00	On a mounting surface with open spaces.
VRKP2•••NC	On a mounting surface with open spaces.
VRKP2•••WD	On a closed mounting surface (except for the mounting holes and the cable gland).
VRKP4•••WD / VRKP4•••NO / VRKP4•••CW	On a closed mounting surface (except for the mounting holes and the cable gland).
VRKP4•••WF	On a closed mounting surface with limited working space or with entire working space on a mounting surface with open spaces.
VRKP4•••NC	On a mounting surface with open spaces.
VRKP5•••WF	On a closed mounting surface with limited working space or with entire working space on a mounting surface with open spaces.
VRKP5•••NC	On a mounting surface with open spaces.
VRKP6•••WF	On a closed mounting surface with limited working space or with entire working space on a mounting surface with open spaces.
VRKP6•••NC	On a mounting surface with open spaces.
VRKP6•••WF••E00	On a closed mounting surface with limited working space or with entire working space on a mounting surface with open spaces.
VRKP6•••NC••E00	On a mounting surface with open spaces.

For further information, refer to the respective dimensional drawing in *Mechanical and Electrical Data*, page 31.

The following figures illustrate the interference areas of the mounting surface for the different robot types.

VRKP••••NC:

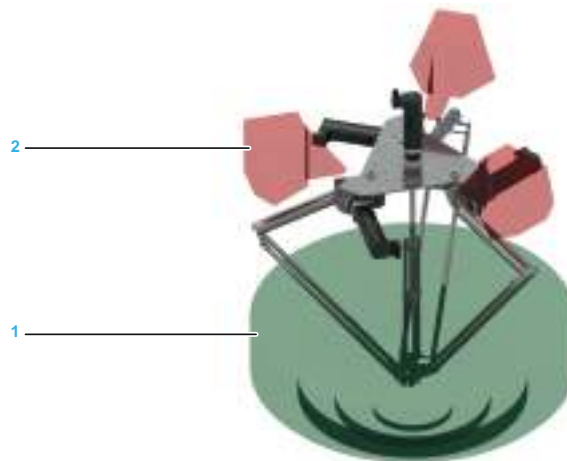

1 Working space

2 Interference area

VRKP••••WF:

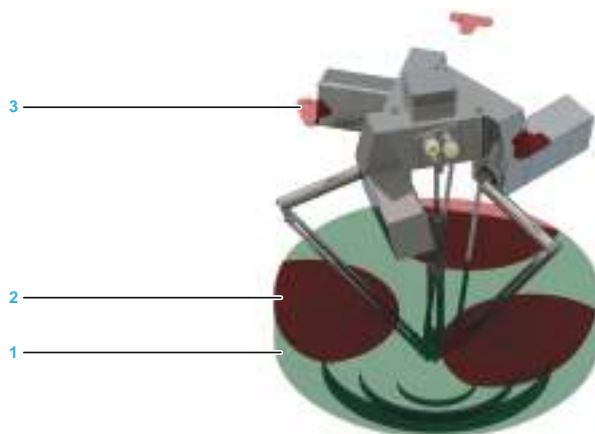

- 1 Working space
- 2 Unavailable working space on a closed mounting surface (not for VRKP0 and VRKP1)
- 3 Interference area (not for VRKP0 and VRKP1)

VRKP••••WD / VRKP••••NO / VRKP••••CW:

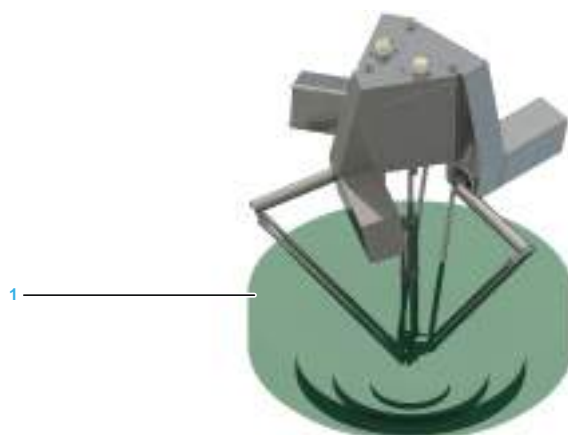

- 1 Working space

For detailed information about the interference areas caused by upper and lower arm movements, refer to the 3D-CAD data on the Schneider Electric homepage (www.se.com) or contact your local Schneider Electric service representative.

Run-On Motions of the Robot for Risk Analysis

Run-On Motions of the Robot for Risk Analysis

Overview

What is measured is the time from the application of a stop signal to the standstill of the robot. This measurement is carried out for various different loads and velocities (measurement according to ISO 10218-1).

⚠ WARNING

BREAKDOWN OF THE INTERNAL MOTOR HOLDING BRAKE

- Do not consider the internal motor holding brake to be a functional safety device.
- Take into account a possible breakdown of the internal motor holding brake during your safety analysis.
- Take into account that the internal motor holding brake of the robot only withstands a limited number of brake operations.

Failure to follow these instructions can result in death, serious injury, or equipment damage.

If there is a power outage of the control system, the brakes are applied and the robot mechanics leave the planned trajectory.

⚠ WARNING

LEAVING THE PLANNED TRAJECTORY OF THE ROBOT MECHANICS

- Use the buffering of the 24 V supply (UPS) in order to enable a controlled stop of the mechanics, in accordance with stop category 1, by making use of the stored residual mechanical and electrical energy.
- Use a synchronous stop on the path to avoid collisions with obstacles.
- Observe the extension of the run-on path while performing your risk analysis.

Failure to follow these instructions can result in death, serious injury, or equipment damage.

Stop Function Categories

The following table presents the stop function categories according to IEC 60204-1 that are related to the product:

Stop function category	Definition	Corresponds to
0	Stopping by immediate removal of power to the machine actuators (for example, an uncontrolled stop).	An uncontrolled stop (stopping of machine motion by removing electrical power to the machine actuators).
1	A controlled stop with power available to the machine actuators to achieve the stop and then removal of power when the stop is achieved.	A controlled stop (stopping of machine motion with power to the machine actuators maintained during the stopping process).

Run-On Path Robot VRKP0

Run-on path of the robot VRKP0 for stop category 0:

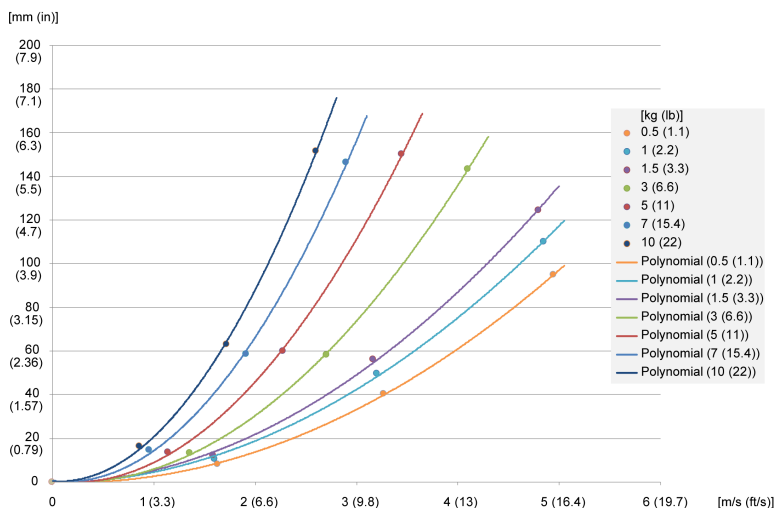

For further information, refer to IEC 60204-1. If necessary, use the holding brake for a stop category 0.

Stopping time of the robot VRKP0 for stop category 0:

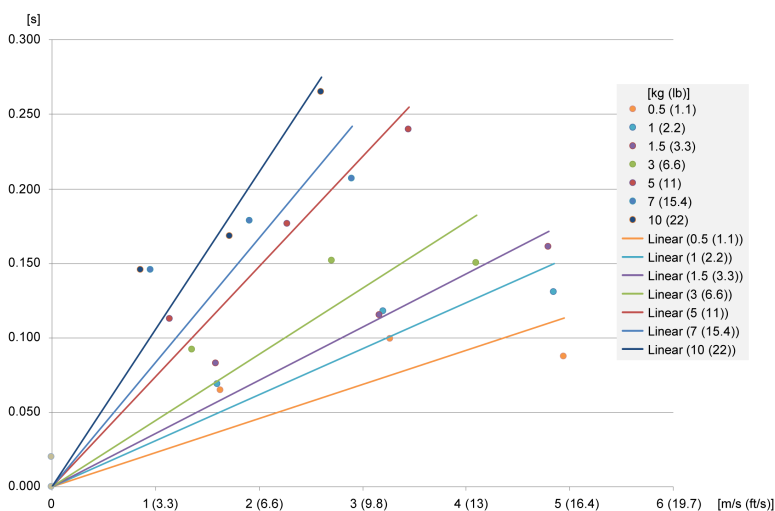

Run-On Path Robot VRKP0.....E00

Run-on path of the robot VRKP0.....E00 for stop category 0:

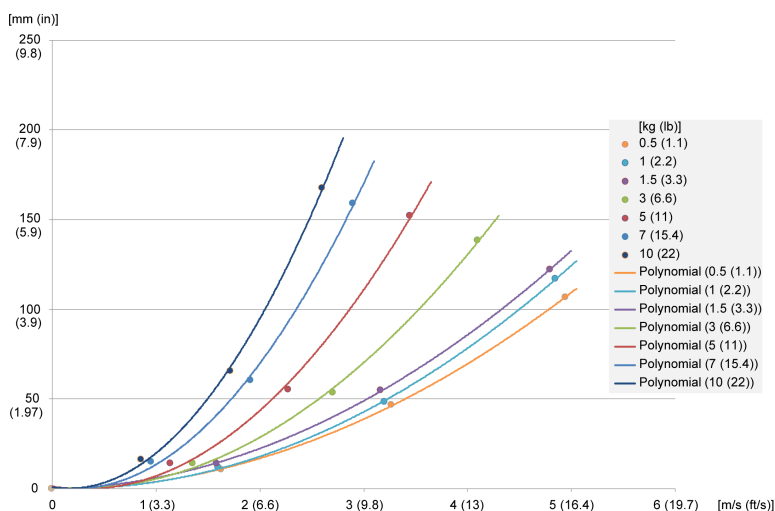

For further information, refer to IEC 60204-1. If necessary, use the holding brake for a stop category 0.

Stopping time of the robot VRKP0.....E00 for stop category 0:

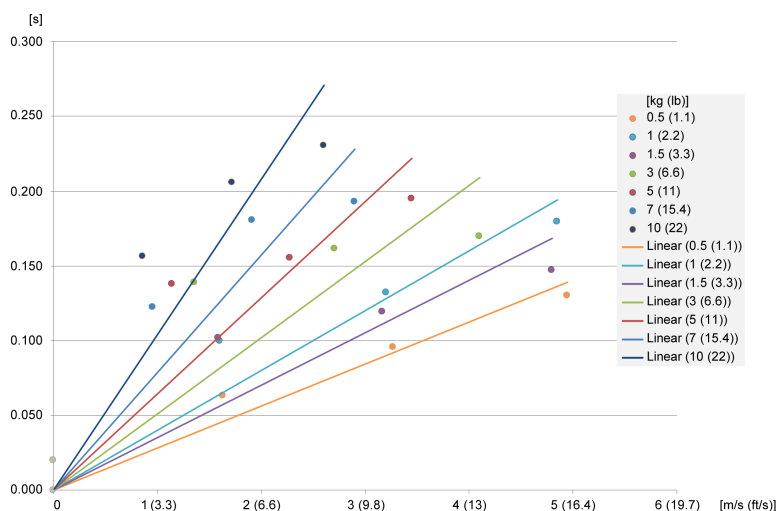

Run-On Path Robot VRKP1

Run-on path of the robot VRKP1 for stop category 0:

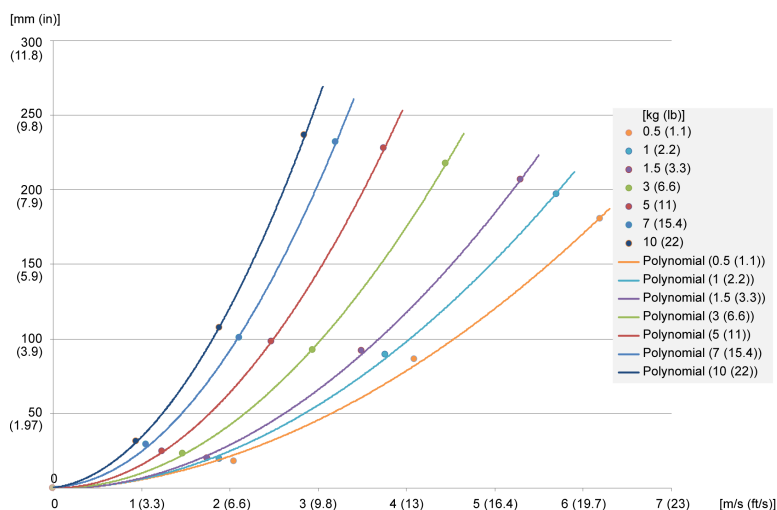

For further information, refer to IEC 60204-1. If necessary, use the holding brake for a stop category 0.

Stopping time of the robot VRKP1 for stop category 0:

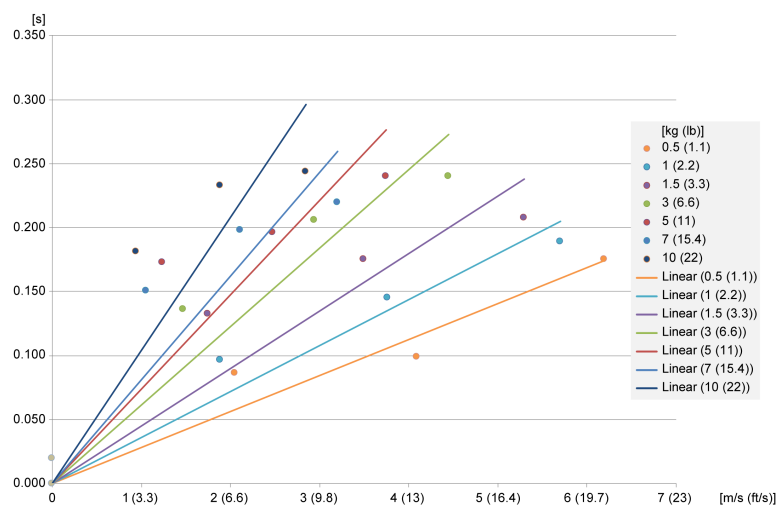

Run-On Path Robot VRKP1.....E00

Run-on path of the robot VRKP1.....E00 for stop category 0:

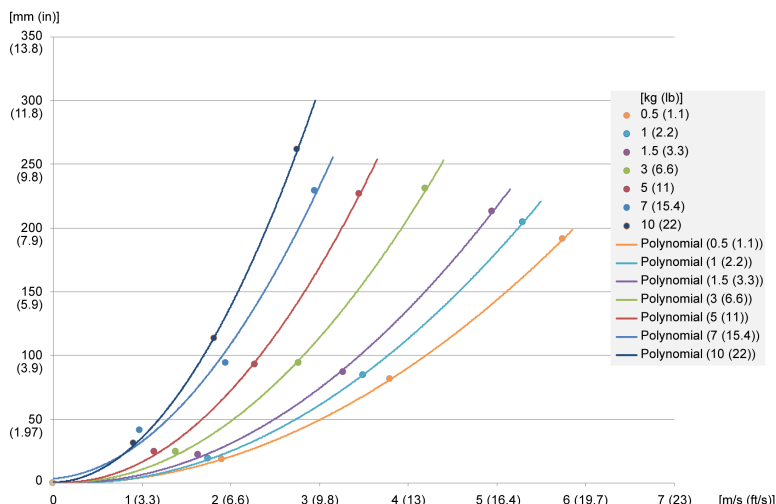

For further information, refer to IEC 60204-1. If necessary, use the holding brake for a stop category 0.

Stopping time of the robot VRKP1.....E00 for stop category 0:

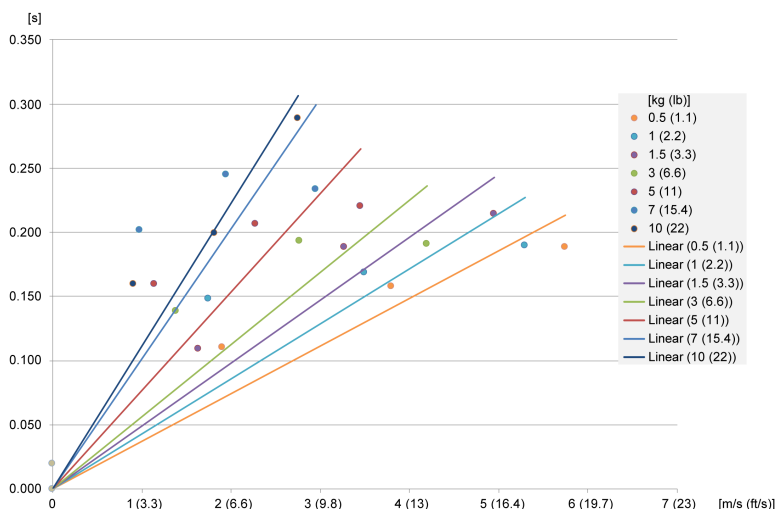

Run-On Path Robot VRKP2

Run-on path of the robot VRKP2 for stop category 0:

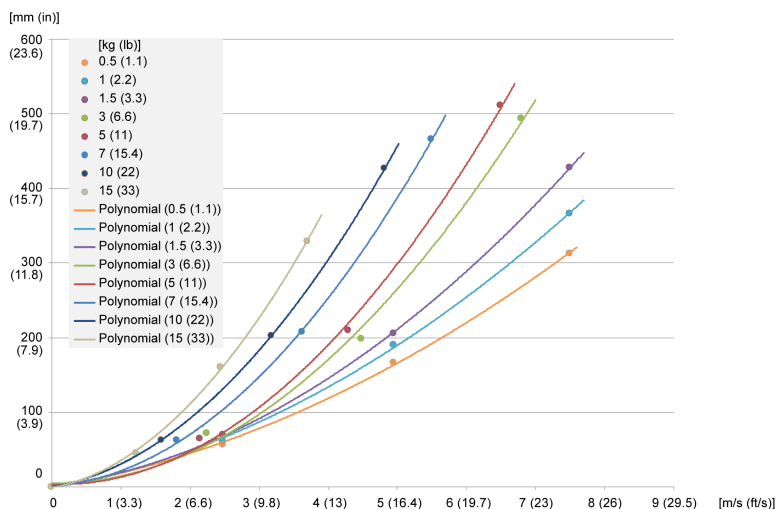

For further information, refer to IEC 60204-1. If necessary, use the holding brake for a stop category 0.

Stopping time of the robot VRKP2 for stop category 0:

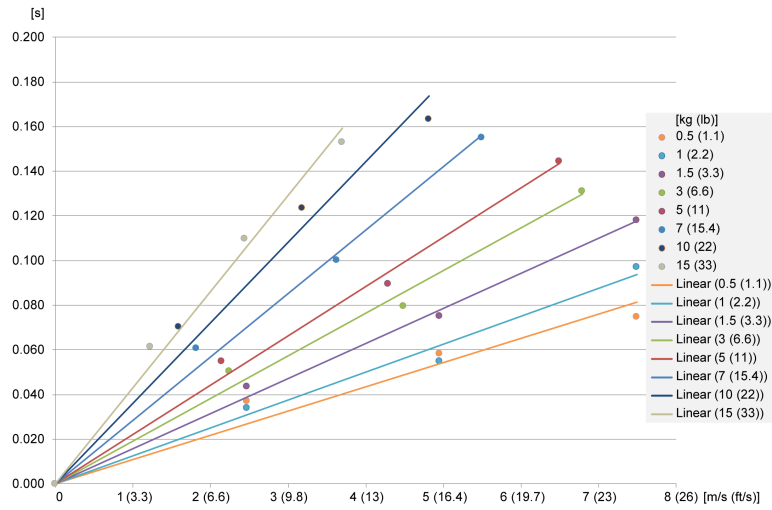

Run-On Path Robot VRKP4

Run-on path of the robot VRKP4 for stop category 0:

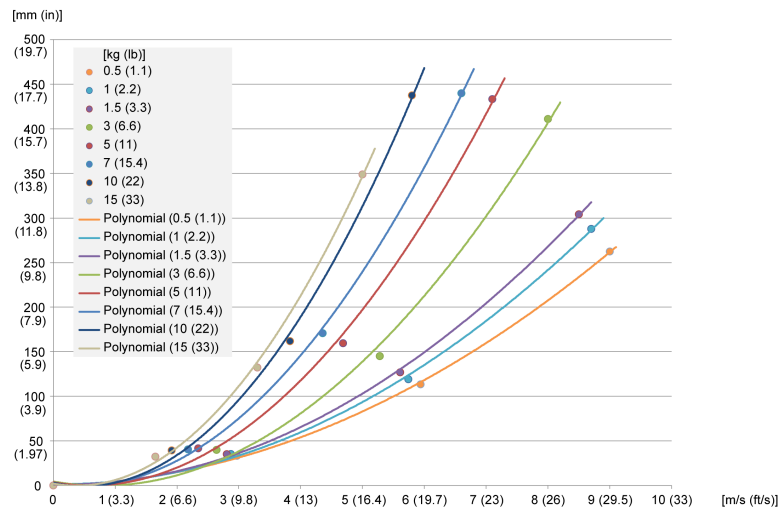

For further information, refer to IEC 60204-1. If necessary, use the holding brake for a stop category 0.

Stopping time of the robot VRKP4 for stop category 0:

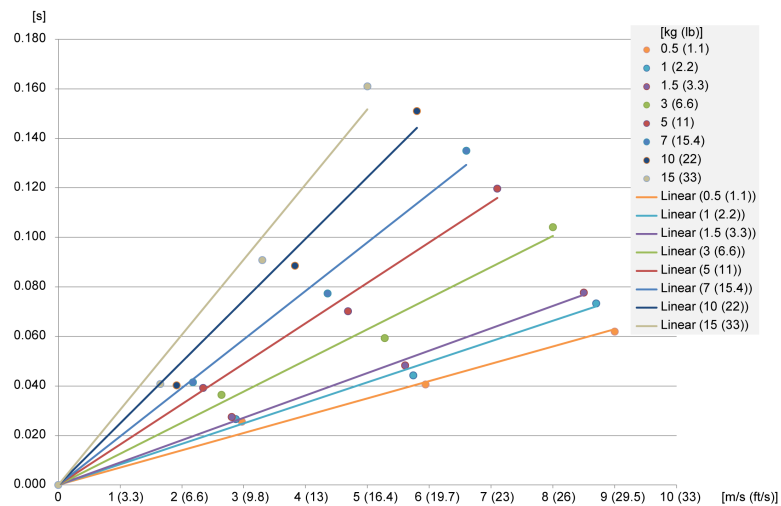

Run-On Path Robot VRKP5

Run-on path of the robot VRKP5 for stop category 0:

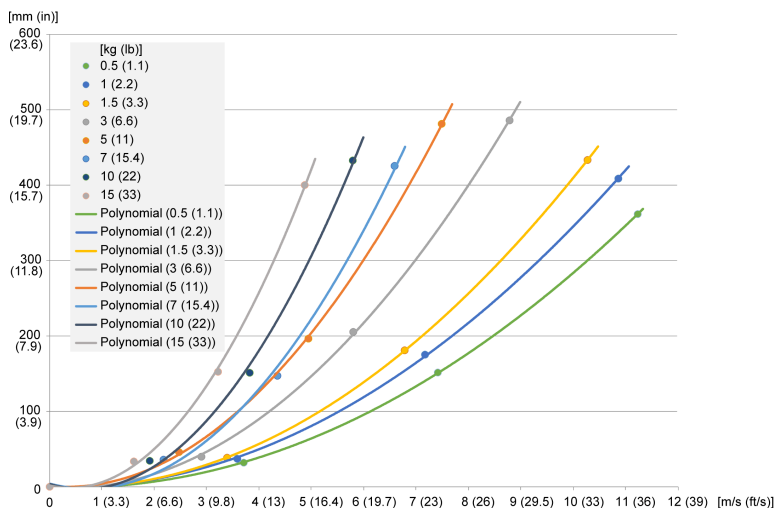

For further information, refer to IEC 60204-1. If necessary, use the holding brake for a stop category 0.

Stopping time of the robot VRKP5 for stop category 0:

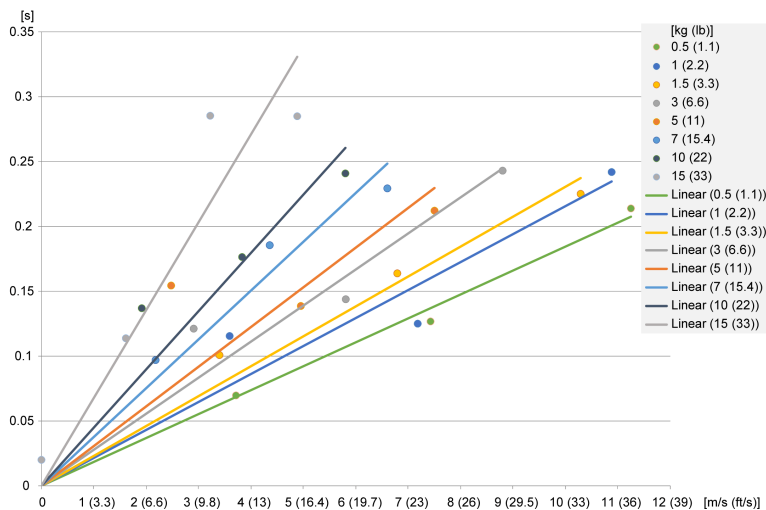

Run-On Path Robot VRKP6

Run-on path of the robot VRKP6 for stop category 0:

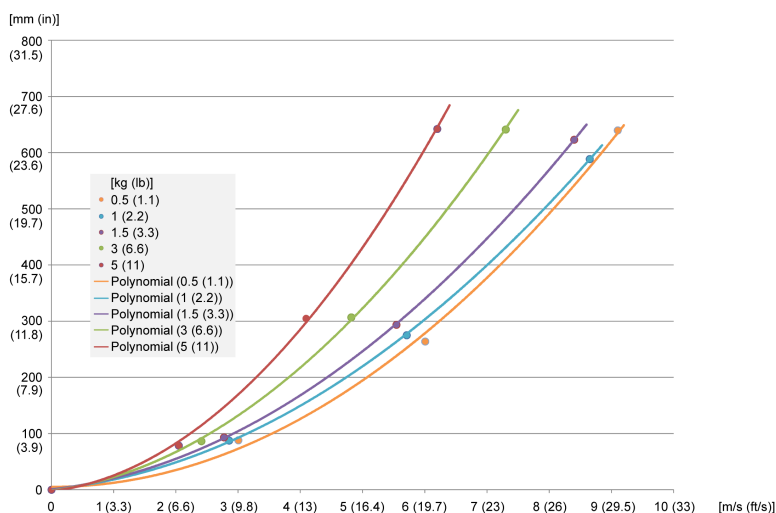

For further information, refer to IEC 60204-1. If necessary, use the holding brake for a stop category 0.

Stopping time of the robot VRKP6 for stop category 0:

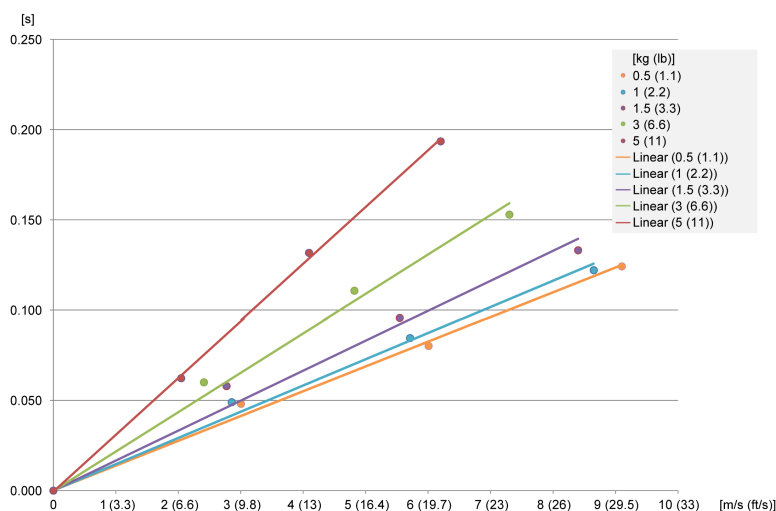

Run-On Path Robot VRKP6.....E00

Run-on path of the robot VRKP6.....E00 for stop category 0:

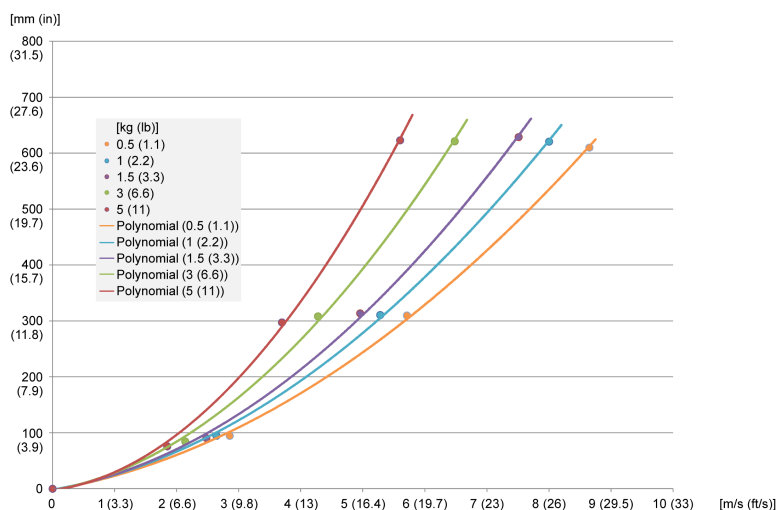

For further information, refer to IEC 60204-1. If necessary, use the holding brake for a stop category 0.

Stopping time of the robot VRKP6.....E00 for stop category 0:

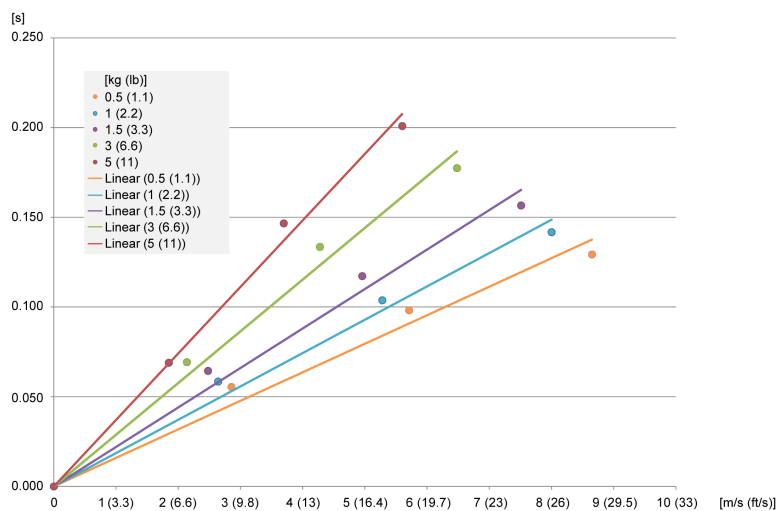

Technical Data of the Motor and the Gearbox

Technical Data of the Motor and the Gearbox

Overview

For further information about the motor, record the motor reference on the type plate and refer to the corresponding motor manual.

For further information about the gearbox, record the gearbox reference on the type plate and refer to the corresponding gearbox manual.

Third-Party Motors

When using a third-party motor, take special care that the maximum permissible drive torque is not exceeded. Otherwise the robot could be rendered inoperable.

⚠ WARNING
UNINTENDED MOVEMENTS
Observe the maximum permissible drive torque of the corresponding motor and gearbox.
Failure to follow these instructions can result in death, serious injury, or equipment damage.

The following table presents the maximum permissible torques at the respective axes.

Parameter	Unit	Robot type	
		VRKP0WM, VRKP0WM.....E00, VRKP1WM, VRKP1WM.....E00	VRKP2WM, VRKP4WM, VRKP5WM, VRKP6WM, VRKP6WM.....E00
Maximum drive torque on the input side of the gearbox at the main axes M_{max}	Nm (lbf-in)	0.9 (7.9)	4 (35.4)
Maximum speed on the input side of the gearbox at the main axes	1/min	7500	
Maximum drive torque on the input side of the gearbox at the rotational axis M_{max}	Nm (lbf-in)	0.45 (4)	
Maximum speed on the input side of the gearbox at the rotational axis	1/min	13000	

NOTE: When using a third-party motor, the protection class of the robot can deviate from that which is stated in *Mechanical and Electrical Data*, page 31. Verify that the protection class corresponds to the environments specified for the robot.

For information about mounting the motor to the gearbox, refer to the corresponding gearbox manual.

The following figure shows the dimensions of the input side of the adapter plate of the gearboxes at the main axes.

VRKP0WM, VRKP0WM.....E00, VRKP1WM, VRKP1WM.....E00

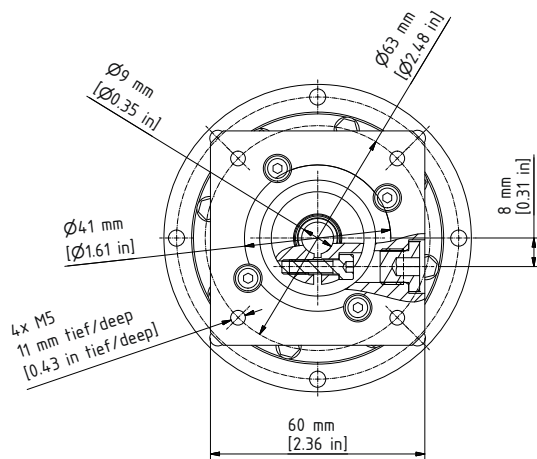

VRKP2WM, VRKP4WM, VRKP5WM, VRKP6WM, VRKP6WM.....E00

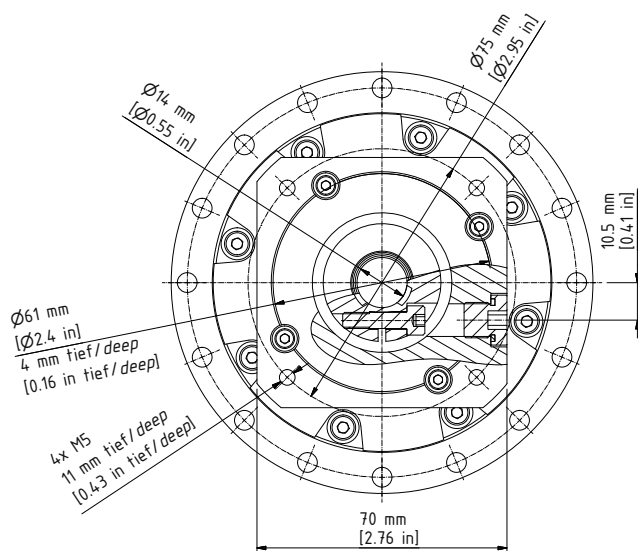

The following figure shows the dimensions of the input side of the adapter plate of the gearbox at the rotational axis.

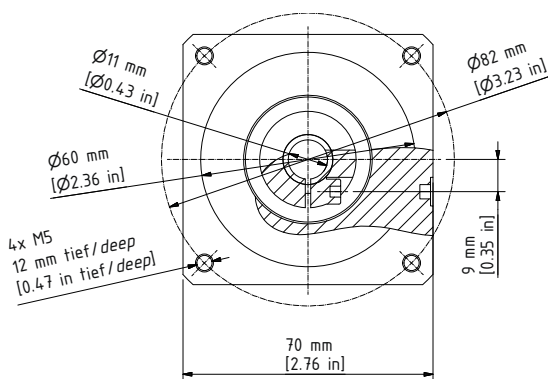

Transport and Commissioning

What's in This Chapter

Transport and Unpacking	104
Mechanical Installation	107
Electrical Installation.....	110
Initial Start-Up	128
Mounting the Payload	140

Transport and Unpacking

Transport and Storage

Transport Conditions

The Lexium P robot must be handled with care. Shocks and impacts may damage the robot. Damage may lead to reduced running accuracy, reduced service life, or to inoperable equipment.

The robot is preassembled before transport.

NOTE: Before unpacking and installing the robot, make sure that the lifting capacity of the lifting devices (forklift truck and crane) is sufficient to lift the robot. You can find the total weight of your equipment on the container or in the transport documents.

For detailed information about transport conditions, refer to *Ambient Conditions*, page 30.

Storage

The Lexium P robot can be stored inside the packaging or unpacked. In both cases, ensure that it is stored in a sheltered and dry place. Avoid humidity which can have corrosive effects on the robot.

For detailed information about storage conditions, refer to *Ambient Conditions*, page 30.

Unpacking

Overview

The following figures show the procedure to unpack and prepare the robot as an example.

Removing the Outer Carton

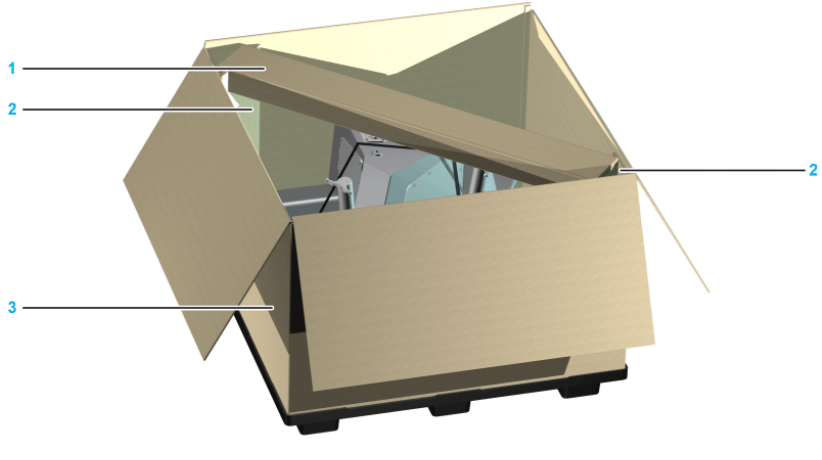
Step	Action
1	Remove the lashing straps from the outer carton.
2	Open the outer carton on the top side and remove the accessories box (1). 
3	Remove both triangular supports (2).
4	Lift up and remove the outer carton (3).

Presentation of the Robot Packaging

The following figure shows the packaging of robots VRKP0, VRKP1, VRKP2, VRKP4, VRKP5, and VRKP6•••WF.

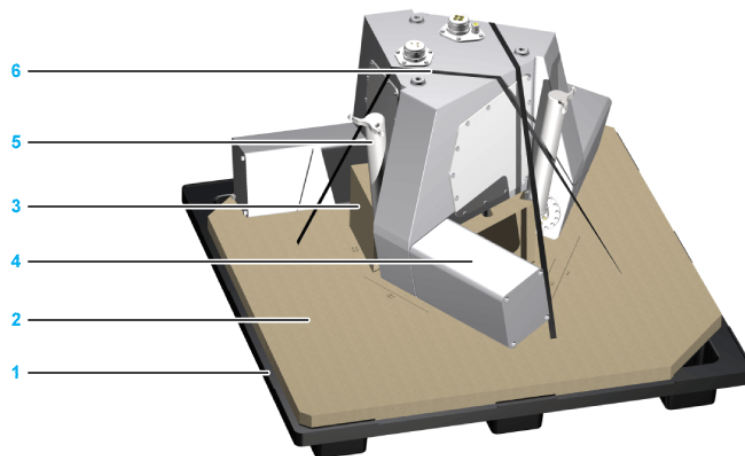

The following figure shows the packaging of robot VRKP6•••NC.

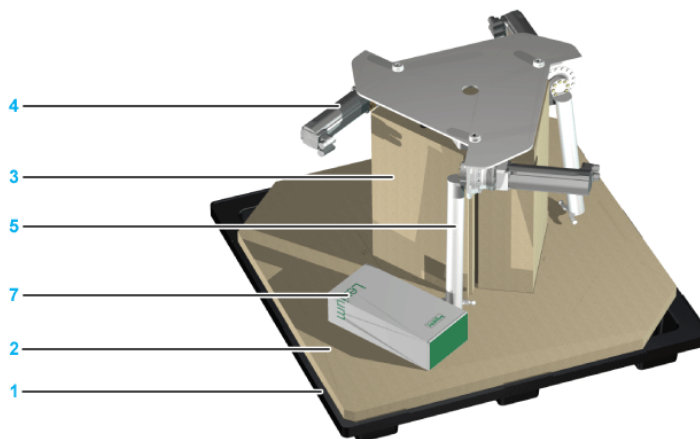

1	Plastic pallet (120 x 120 cm (47 in x 47 in))
2	Base carton
3	Carton block (where the housing sits)
4	Motor covers (suspended above the base carton)

5	Upper arms in transportation position
6	Lashing straps
7	Package containing the rotational axis motor and gearbox

NOTE: In case of VRKP6•••MNC the motorized module is packed inside the robot packaging in a carton.

Preparing the Robot for Installation

Refer to the previous figures under *Presentation of the Robot Packaging*, page 105 for the following steps:

Step	Action
1	Remove the robot lashing straps (6).
2	Only for VRKP6 robots with a rotational axis (VRKP6••R): Remove the additional carton containing the rotational motor and gearbox (7).
3	Verify the robot for transport damage.

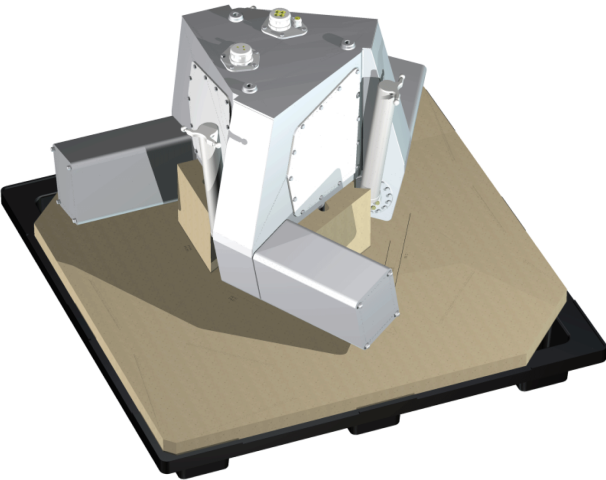
Step	Action
4	<p>Open the accessories box and verify all included parts for transport damage and completeness.</p> <p>It must contain:</p> <ul style="list-style-type: none"> • 1x telescopic axis (only for robots with a rotational axis: VRKP•••R) • 3x lower arm pairs • 1x parallel plate • 1x documentation DVD • 33x screws with sealing washers for maintenance covers (only for robots with a standard housing: VRKP••••WD / VRKP••••NO) • 3x cable glands (only for robots VRKP2S0•WD / VRKP4S0•WD / VRKP4S0•NO / VRKP4S0•CW)
5	<p>Only for robots with a standard housing (VRKP••••WD / VRKP••••NO):</p> <p>Remove the three bolts of each maintenance cover and remove the maintenance covers.</p> 

NOTE: The variants VRKP4L0•WD / VRKP4L0•NO only have one media cover on the upper side. The second aperture is not covered at this variant and must remain open for ventilation.

NOTE: In case of transport damages, contact your local Schneider Electric service representative.

For information on the disposal of the packaging, refer to *Disposal*, page 251.

Mechanical Installation

Information About Installation

Proceed with care during the following steps in order to help to prevent the following points:

- Injuries and material damage
- Incorrect installation and programming of components
- Incorrect operation of components
- Use of non-authorized cables or modified components

For further Information, refer to *Hazard Information*, page 12.

Mounting the Robot

Overview

There are two ways of proceeding for handling and mounting of the robot. Study both ways of proceeding and determine which one would be appropriate for your environment.

Installing by Forklift Truck

⚠ WARNING

FALLING LOADS

- Drive slowly and carefully with the forklift truck.
- Do not carry out any sudden steering movements.
- Exercise care when initiating height adjustments of the forklift truck loading platform.

Failure to follow these instructions can result in death, serious injury, or equipment damage.

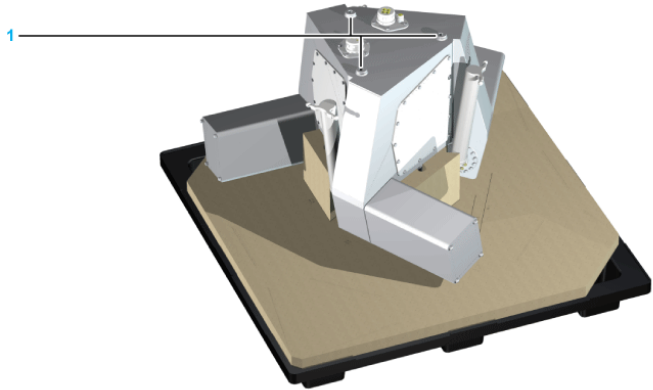
Step	Action
1	<p>Using a forklift truck, lift the robot and the pallet into the enclosure.</p> 
2	<p>Fasten the robot to the frame by using the three provided threaded holes (1). Tightening torque and size of the threaded holes:</p> <ul style="list-style-type: none"> • At VRKP0 / VRKP1: Size: M12 Tightening torque: 54 Nm (478 lbf-in) • At VRKP2 / VRKP4 / VRKP5 / VRKP6: Size: M16 Tightening torque: 100 Nm (855 lbf-in) <p>Property class of the screws: 8.8 or greater, or A2-70 or greater</p> 
3	<p>Remove the carton block, the base carton, and the plastic pallet from the robot.</p>

For information on the disposal of the packaging, refer to *Disposal*, page 251.

Installing by Crane

NOTE: The motor covers cannot carry the weight of the robot.

⚠ WARNING

FALLING HEAVY LOAD

- Attach lifting lugs to the robot body only.
- Do not attach lifting lugs to the motor covers or the motors.

Failure to follow these instructions can result in death, serious injury, or equipment damage.

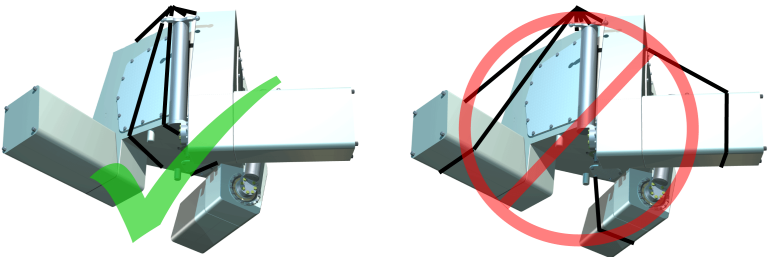
Step	Action
1	<p>Pull the three lifting lugs underneath the robot.</p> 
2	<p>Use the crane to carefully lift the robot into the enclosure.</p>
3	<p>Fasten the robot to the frame by using the three provided threaded holes (1). Tightening torque and size of the threaded holes:</p> <ul style="list-style-type: none"> At VRKP0 / VRKP1: Size: M12 Tightening torque: 54 Nm (478 lbf-in) At VRKP2 / VRKP4 / VRKP5 / VRKP6: Size: M16 Tightening torque: 100 Nm (855 lbf-in) <p>Property class of the screws: 8.8 or greater, or A2-70 or greater</p>

Electrical Installation

Opening the Robots VRKP...WD / VRKP...NO / VRKP...CW / VRKP...WF for Cabling

Overview

The robot types VRKP...WD / VRKP...NO / VRKP...CW and VRKP...WF are equipped with protective covers, which must be removed before cabling the robot.

Opening the Robots VRKP...WD / VRKP...NO / VRKP...CW / VRKP...WF for Cabling

Step	Action
1	<p>Verify whether the application requires a strain relief.</p> <p>NOTE: The motor cover is heavy (approximately 5 kg (11 lb)) and could cause damage or injury if it were to fall during removal.</p>
2	<p>Loosen the four threaded rods (1) at the rear end of the motor cover.</p> 

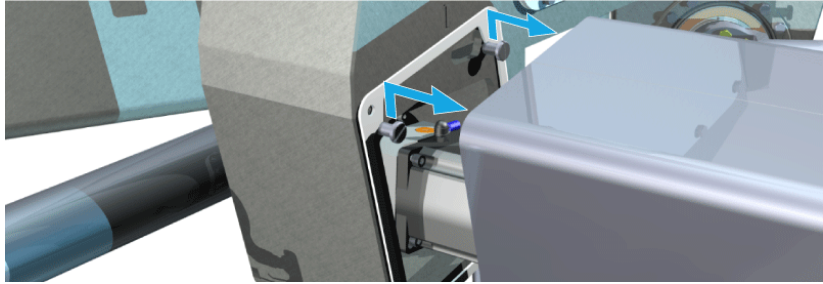
Step	Action
3	Slightly lift the motor cover and remove it to the rear. 
4	Remove the screws and washers (2) from the maintenance cover (3) and then remove the maintenance cover complete with the sealing gasket.
5	Repeat the process for all the other protective covers.

⚠ CAUTION

FALLING HEAVY MOTOR COVER

Secure in place the motor cover while loosening the screws.

Failure to follow these instructions can result in injury or equipment damage.

NOTE: Keep all covers, bolts, and sealing gaskets to remount them later.

Cabling the VRKP•S0•WD / VRKP•S0•CW

Procedure Overview

Perform the following procedures to cable the robot:

- Preparing the cable connections, page 111
- Connecting the components of the robot, page 112
- Cabling the fans (only for VRKP2S0•WD), page 114

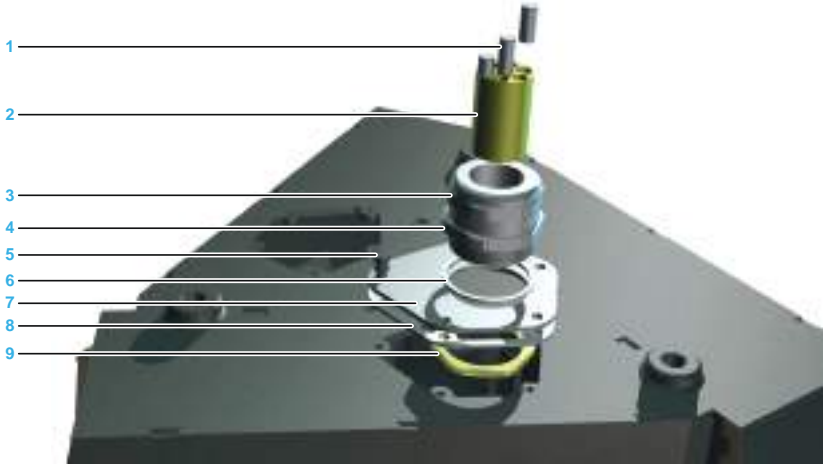

Preparing the Cable Connections

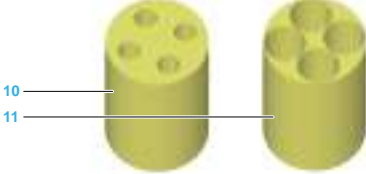
Step	Action
1	Remove the five screws and washers (5) from the media cover (7). 
2	Remove the media cover with the mounted M50 cable connections and the media cover sealing gasket (8).

Step	Action
3	Dismount the two M50 cable connections: <ul style="list-style-type: none"> • Unscrew the M50 cable connection from the locknut (9). • Remove the sealing ring (6) from the M50 cable connection. • Unscrew the top half (3) of the M50 cable connection from the lower half (4).
4	Remove the sealing inserts (2) from the cable glands of the M50 cable connections.
5	Laterally slit each sealing insert in accordance with the respective number of cables to be routed.
6	Feed the three encoder cables (four with VRKP***R) first through the top half of the M50 cable connection and next through the insert with the smaller apertures (10).  <ul style="list-style-type: none"> • Using the slits, press the cables from outside into the sealing inserts. • Feed each cable with a minimum cable length of 1.5 m (39.4 in) from the M50 cable connection to the motor connector.
7	Feed the three power cables (four with VRKP***R) first through the top half of the M50 cable connection and next through the insert with the larger apertures (11).
8	Close any not required gland of the insert with a sealing plug (1).
9	Feed the cables through the lower halves of the M50 cable connections and insert the sealing inserts into them.
10	Close the two halves of each M50 cable connection. Tightening torque: 10 Nm (89 lbf-in)

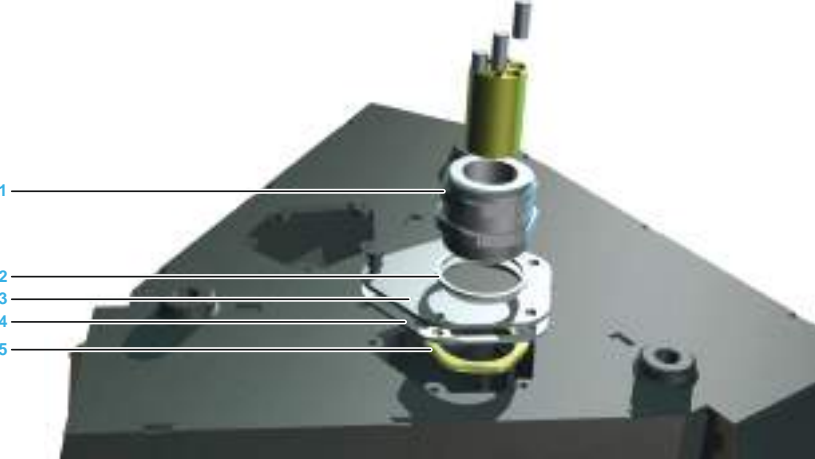
Connecting the Components of the Robot

Step	Action
1	Insert the sealing ring (2) between the M50 cable connection (1) and the media covers (3) and fasten the M50 cable connection to the media cover with the locknut (5). Tightening torque: 10 Nm (89 lbf-in) 
2	Feed the ground cables (protective earth ground) through the top half of the M16 cable connection and next through the sealing insert.
3	Only for VRKP2S0•WD: Feed the cable for fan connection (+24 Vdc supply) through the top half of the second M16 cable connection and next through the sealing insert.
4	Fasten the M16 cable connection to the media cover the same way as the M50 cable connection. Tightening torque: 6 Nm (53 lbf-in)

Step	Action
5	Feed the encoder cables, the power cables, and the ground cables (protective earth ground) through the media cover sealing gasket (4) and insert them into the opening of the robot housing. NOTE: For equipment that you are supplying that is not described in the present document, consult the documentation for those products.
6	Feed the encoder and the power cables to the motors.
7	Attach the encoder and the power cables as described in the <i>SH3 Servo motor Motor Manual</i> .
8	Fasten each of the media covers including the media cover sealing gasket with the five screws and washers (6). Tightening torque: 6 Nm (53 lbf-in) 
9	Couple the DC buses of the servo amplifiers so that braking motors can feed back their power to the accelerating motors in the case of an on-path stop of the robot. Due to the coupling of the DC buses, the existing energy suffices in many cases for an on-path stop of the robot. In case of a power outage of the 24 Vdc supply this backfeeding measure does not have any effect. For more information, see <i>Lexium 52 Hardware Guide</i> or <i>Lexium 62 Hardware Guide</i> . NOTE: When routing the cables, ensure that the grounding cap (7) remains on the ground connection of the motors. The motor supply cable may become damaged by the thread of the ground strap attachment. 
10	Verify the correct routing and fastening of the cables to help prevent any collision of cables and moving parts.

⚠️ ⚠️ DANGER

LOOSE WIRING OR CABLING CAUSES ELECTRIC SHOCK

Tighten wiring or cabling connections in conformance with the torque specifications.

Failure to follow these instructions will result in death or serious injury.

⚠️ ⚠️ DANGER

ELECTRIC SHOCK DUE TO DAMAGED CABLES

Verify that the grounding cap is placed correctly on the grounding connection of the motor.

Failure to follow these instructions will result in death or serious injury.

NOTICE**INCORRECT PAIRING OF MOTOR AND ENCODER CABLES**

Label the motor and associated encoder cables according to their pairing.

Failure to follow these instructions can result in equipment damage.

NOTICE**LOSS OF IP65 DEGREE OF PROTECTION**

Replace each sealing gasket every time you remove the media cover.

Failure to follow these instructions can result in equipment damage.

Cabling the Fans (Only for VRKP2S0•WD)

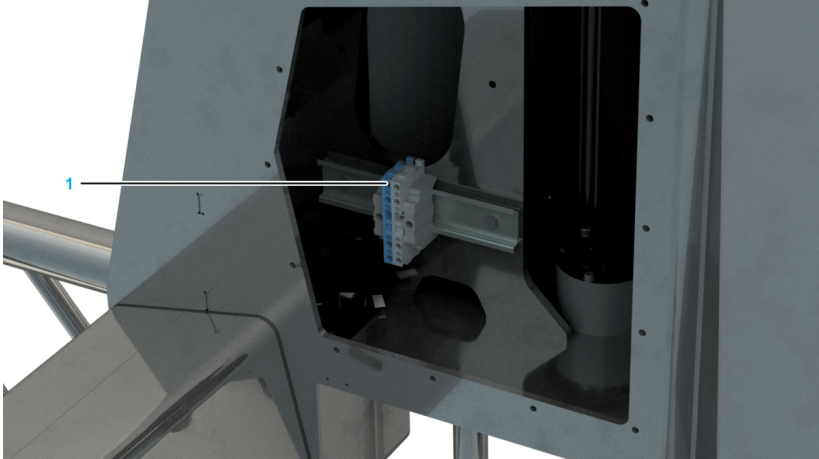
Step	Action
1	<p>Feed the cable for fan connection (+24 Vdc supply) to the terminal strip (1) inside the housing.</p> 
2	Connect the 0 Vdc conductor to the blue multiple terminal.
3	<p>Connect the +24 Vdc line to the gray multiple terminal.</p> <p>NOTE: For the distribution of the +24 Vdc supply for further customer-specific installations, use the following Schneider Electric accessories:</p> <ul style="list-style-type: none"> • Blue terminal: NSYTTR24BL • Gray terminal: NSYTTR24 • End stop bracket: NSYTRAABV35
4	Verify the correct routing and fastening of the cables to help prevent any collision of cables and moving parts.
5	Verify that the fans take air from the central area of the housing and blow this air to the motor cover area.

⚡⚠ DANGER**LOOSE WIRING OR CABLING CAUSES ELECTRIC SHOCK**

Tighten wiring or cabling connections in conformance with the torque specifications.

Failure to follow these instructions will result in death or serious injury.

Cabling the VRKP•S0•WF

Procedure Overview

Perform the following procedures to cable the robot:

- Preparing the cable connections, page 115
- Connecting the components of the robot, page 116
- Cabling the fans, page 118

Preparing the Cable Connections

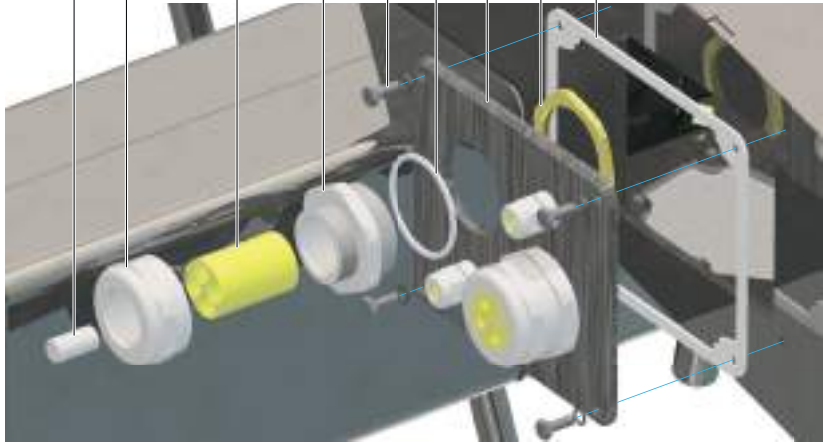
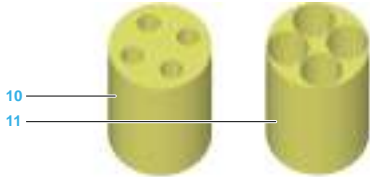
Step	Action
1	Remove the four screws and washers (5) from the media cover (7). 
2	Remove the media cover with the mounted cable connections and the media cover sealing gasket (9).
3	Dismount the two M50 cable connections: <ul style="list-style-type: none"> • Unscrew the M50 cable connection from the locknut (8). • Remove the sealing ring (6) from the M50 cable connection. • Unscrew the top half (2) of the M50 cable connection from the lower half (4).
4	Remove the sealing inserts (3) from the cable glands of the M50 cable connections.
5	Laterally slit each sealing insert in accordance with the respective number of cables to be routed.
6	Feed the three encoder cables (four with VRKP•••R) first through the top half of the M50 cable connection and next through the sealing insert with the smaller apertures (10).  NOTE: <ul style="list-style-type: none"> • Using the slits, press the cables from outside into the sealing inserts. • Feed each cable with a minimum cable length of 1.5 m (39.4 in) from the cable connection to the motor connector.
7	Feed the three power cables (four with VRKP•••R) first through the top half of the M50 cable connection and next through the sealing insert with the larger apertures (11).
8	Close any not required gland of the sealing insert with a sealing plug (1).
9	Feed the cables through the lower halves of the M50 cable connections and insert the sealing inserts into them.
10	Close the two halves of each M50 cable connection. Tightening torque: 10 Nm (89 lbf-in)

Connecting the Components of the Robot

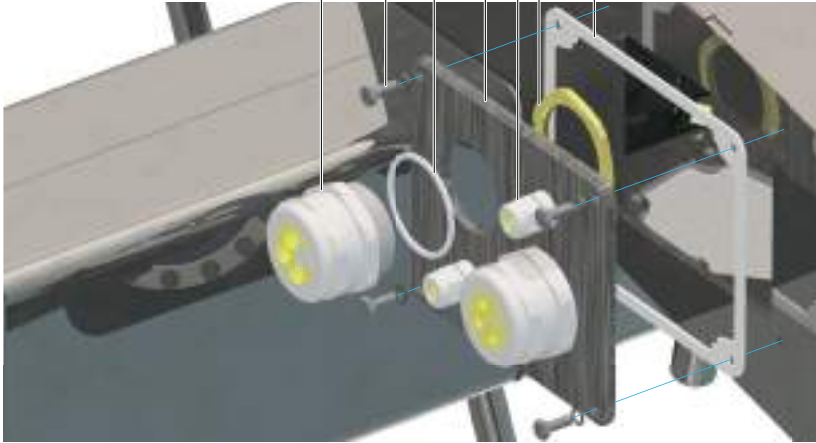
Step	Action
1	<p>Insert the sealing ring (3) between the M50 cable connections (1) and the media cover (4) and fasten the M50 cable connections to the media cover with the locknut (6).</p> <p>Tightening torque: 10 Nm (89 lbf-in)</p> 
2	Feed the ground cables (protective earth ground) through the top half of one M16 cable connection (5) and next through the sealing insert.
3	Feed the cable for fan connection (+24 Vdc supply) through the top half of the second M16 cable connection and next through the sealing insert.
4	<p>Fasten both M16 cable connections to the media cover the same way as the M50 cable connection.</p> <p>Tightening torque: 6 Nm (53 lbf-in)</p>
5	<p>Feed the encoder cable, the power cable, the fan cable, and the ground cables (protective earth ground) through the media cover sealing gasket (7) and insert them into the opening of the robot housing.</p> <p>NOTE: For equipment that you are supplying that is not described in the present document, consult the documentation for those products.</p>
6	Feed the encoder and the power cables to the motors.
7	Attach the encoder and the power cables as described in the <i>SH3 Servo motor Motor Manual</i> and the <i>MH3 Servo motor Motor Manual</i> .
8	<p>Fasten the media covers including the media cover sealing gasket with the four screws and washers (2).</p> <p>Tightening torque: 6 Nm (53 lbf-in)</p>

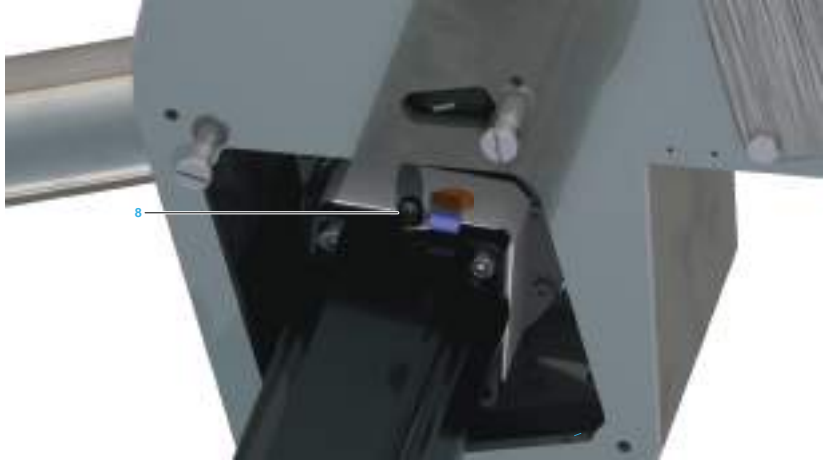
Step	Action
9	<p>Couple the DC buses of the servo amplifiers so that braking motors can feed back their power to the accelerating motors in the case of an on-path stop of the robot. Due to the coupling of the DC buses, the existing energy suffices in many cases for an on-path stop of the robot. In case of a power outage of the 24 Vdc supply this backfeeding measure does not have any effect.</p> <p>For more information, see <i>Lexium 52 Hardware Guide</i> or <i>Lexium 62 Hardware Guide</i>.</p> <p>NOTE: When routing the cables, ensure that the grounding cap (8) remains on the ground connection of the motors. The motor supply cable may become damaged by the thread of the ground strap attachment.</p> 
10	<p>Verify the correct routing and fastening of the cables to help prevent any collision of cables and moving parts.</p>

⚡ ⚠ DANGER

LOOSE WIRING OR CABLING CAUSES ELECTRIC SHOCK

Tighten wiring or cabling connections in conformance with the torque specifications.

Failure to follow these instructions will result in death or serious injury.

⚡ ⚠ DANGER

ELECTRIC SHOCK DUE TO DAMAGED CABLES

Verify that the grounding cap is placed correctly on the grounding connection of the motor.

Failure to follow these instructions will result in death or serious injury.

NOTICE

INCORRECT PAIRING OF MOTOR AND ENCODER CABLES

Label the motor and associated encoder cables according to their pairing.

Failure to follow these instructions can result in equipment damage.

NOTICE

LOSS OF IP65 DEGREE OF PROTECTION

Replace each sealing gasket every time you remove the media cover.

Failure to follow these instructions can result in equipment damage.

Cabling the Fans

Step	Action
1	Feed the cable for fan connection (+24 Vdc supply) to the terminal strip (1) inside the housing. 
2	Connect the 0 Vdc conductor to the blue multiple terminal.
3	Connect the +24 Vdc line to the gray multiple terminal. NOTE: For the distribution of the +24 Vdc supply for further customer-specific installations, use the following Schneider Electric accessories: <ul style="list-style-type: none"> • Blue terminal: NSYTRR24BL • Gray terminal: NSYTRR24 • End stop bracket: NSYTRAABV35
4	Verify the correct routing and fastening of the cables to help prevent any collision of cables and moving parts.
5	Verify that the fans take air from the central area of the housing and blow this air to the motor cover area.

⚡⚠ DANGER

LOOSE WIRING OR CABLING CAUSES ELECTRIC SHOCK

Tighten wiring or cabling connections in conformance with the torque specifications.

Failure to follow these instructions will result in death or serious injury.

Cabling the VRKP•S0•NC

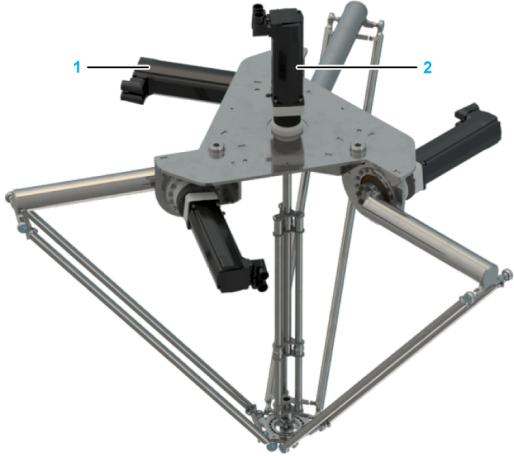
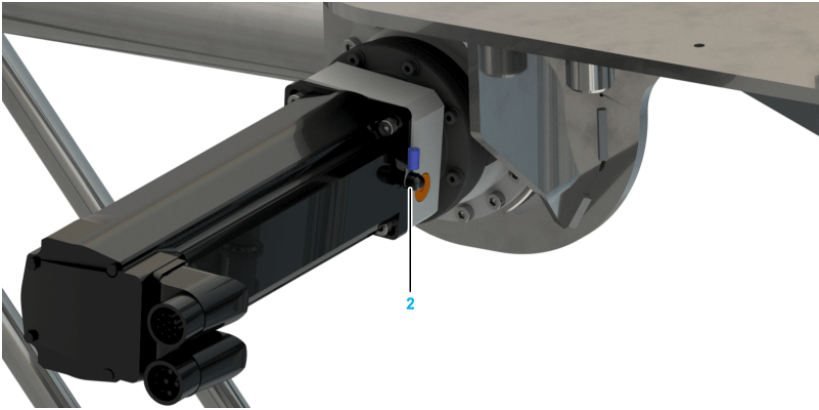
Step	Action
1	<p>Feed the three encoder cables (four with VRKP0S0R / VRKP1S0R / VRKP2S0R / VRKP4S0R / VRKP5S0R / VRKP6S0R (2)) directly to the motors (1).</p>  <p>For robots with a motorized module:</p> <p>Cable the motorized module according to the cabling instructions of the respective module:</p> <ul style="list-style-type: none"> • Cabling the Rotational Modules, page 160 • Cabling the Rotational Tilting Modules, page 188 • Cabling the Double Rotational Modules, page 177 • Cabling the Tilting Modules, page 168
2	<p>Feed the three power cables (four with VRKP0S0R / VRKP1S0R / VRKP2S0R / VRKP4S0R / VRKP5S0R / VRKP6S0R) directly to the motors.</p> <p>NOTE: For equipment that you are supplying that is not described in the present document, consult the documentation for those products.</p>
3	<p>Attach the encoder and the power cables as described in the <i>SH3 Servo motor Motor Manual</i> and the <i>MH3 Servo motor Motor Manual</i>.</p>
4	<p>Couple the DC buses of the servo amplifiers so that braking motors can feed back their power to the accelerating motors in the case of an on-path stop of the robot. Due to the coupling of the DC buses, the existing energy suffices in many cases for an on-path stop of the robot. In case of a power outage of the 24 Vdc supply this backfeeding measure does not have any effect.</p> <p>For more information, see <i>Lexium 52 Hardware Guide</i> or <i>Lexium 62 Hardware Guide</i>.</p> <p>NOTE: When routing the cables, ensure that the grounding cap (2) remains on the ground connection of the motors. The motor supply cable may become damaged by the thread of the ground strap attachment.</p> 
5	<p>Verify the correct routing and fastening of the cables to help prevent any collision of cables and moving parts.</p>

⚡⚠ DANGER

ELECTRIC SHOCK DUE TO DAMAGED CABLES

Verify that the grounding cap is placed correctly on the grounding connection of the motor.

Failure to follow these instructions will result in death or serious injury.

⚡⚠ DANGER

LOOSE WIRING OR CABLING CAUSES ELECTRIC SHOCK

Tighten wiring or cabling connections in conformance with the torque specifications.

Failure to follow these instructions will result in death or serious injury.

NOTICE

INCORRECT PAIRING OF MOTOR AND ENCODER CABLES

Label the motor and associated encoder cables according to their pairing.

Failure to follow these instructions can result in equipment damage.

Cabling the VRKP•L0•WD / VRKP•L0•NO

Procedure Overview

Perform the following procedures to cable the robot:

- Connecting the components of the robot, page 120
- Cabling the fans, page 121

NOTE: The VRKP•L0•WD / VRKP•L0•NO do not have any cable gland.

Connecting the Components of the Robot

NOTE: The motors are already connected to the X2-X5 connections before they leave the factory.

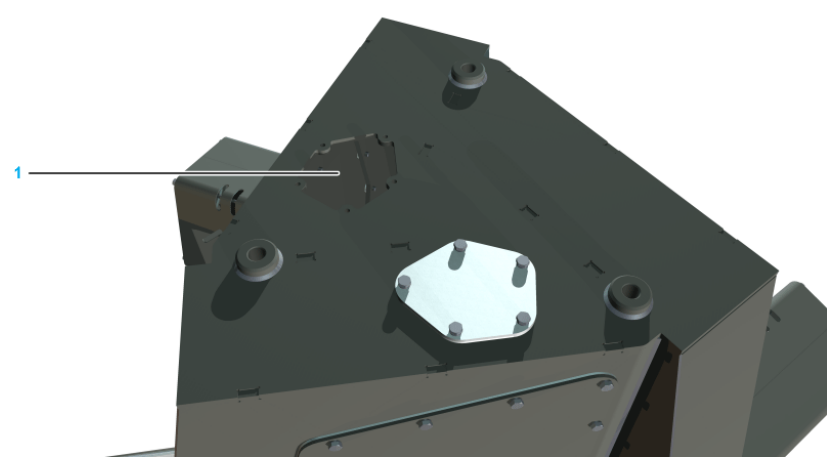
Step	Action
1	Feed the hybrid cable from the Lexium 62 Connection Module or from another Lexium 62 Distribution Box through the unclosed aperture (1) on the upper side of the housing. 
2	Feed the ground cables (protective earth ground) and the cable for fan connection (+24 Vdc supply) through the aperture of the housing.

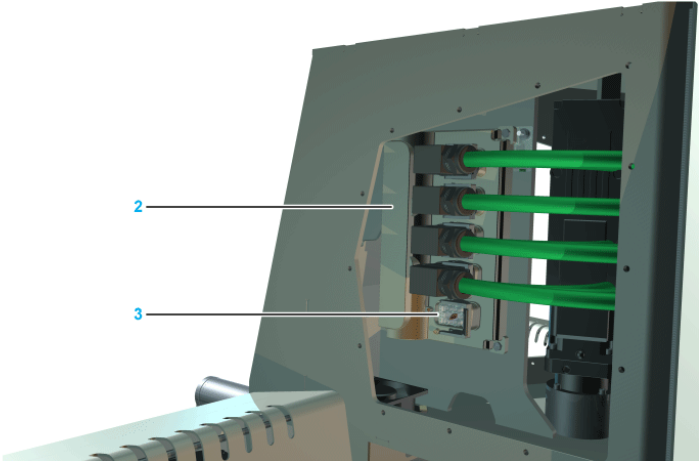
Step	Action
3	<p>Feed the hybrid cable with a minimum cable length of 0.5 m (19.7 in) from the aperture to the connection point of the internal Lexium 62 Distribution Box (2).</p>  <p>NOTE: For equipment that you are supplying that is not described in the present document, consult the documentation for those products.</p>
4	<p>Attach the hybrid cable to the connection X1 as described in the <i>Lexium 62 ILM Hardware Guide</i> (3).</p>
5	<p>Verify the correct routing and fastening of the cables to help prevent any collision of cables and moving parts.</p>

⚠️ ⚠️ DANGER

LOOSE WIRING OR CABLING CAUSES ELECTRIC SHOCK

Tighten wiring or cabling connections in conformance with the torque specifications.

Failure to follow these instructions will result in death or serious injury.

For further information on the connection of the Lexium 62 Distribution Box, refer to the *Lexium 62 ILM Hardware Guide*.

Cabling the Fans

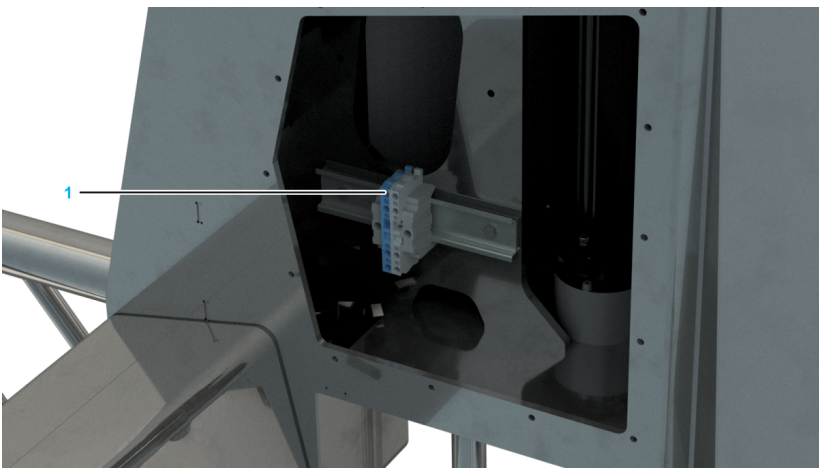
Step	Action
1	<p>Feed the cable for fan connection (+24 Vdc supply) to the terminal strip (1) inside the housing.</p> 
2	<p>Connect the 0 Vdc conductor to the blue multiple terminal.</p>

Step	Action
3	<p>Connect the +24 Vdc line with the gray multiple terminal.</p> <p>For the distribution of the +24 Vdc supply for further customer-specific installations, use the following Schneider Electric accessories:</p> <ul style="list-style-type: none"> • Blue terminal: NSYTTR24BL • Gray terminal: NSYTTR24 • End stop bracket: NSYTRAABV35
4	Verify the correct routing and fastening of the cables to help prevent any collision of cables and moving parts.
9	Verify that the fans take air from the central area of the housing and blow it out through the slits in the motor covers.

DANGER

LOOSE WIRING OR CABLING CAUSES ELECTRIC SHOCK

Tighten wiring or cabling connections in conformance with the torque specifications.

Failure to follow these instructions will result in death or serious injury.

Cabling the VRKP•L0•NC

Step	Action
1	<p>Select the connector from of the ILM hybrid cable on motor side: D1 (for example, cable ref.: VW3E1142R•••)</p> <p>NOTE: For equipment that you are supplying that is not described in the present document, consult the documentation for those products.</p>
2	<p>Feed the three hybrid cables (four with VRKP2L0R / VRKP4L0R / VRKP5L0R / VRKP6L0R (2)) from a Lexium 62 Distribution Box directly to the motors (1).</p> 
3	Attach the hybrid cables as described in the <i>Lexium 62 ILM Hardware Guide</i> .
4	Verify the correct routing and fastening of the cables to help prevent any collision of cables and moving parts.

DANGER

LOOSE WIRING OR CABLING CAUSES ELECTRIC SHOCK

Tighten wiring or cabling connections in conformance with the torque specifications.



Failure to follow these instructions will result in death or serious injury.

For further information on the connection of the Lexium 62 Distribution Box, refer to the *Lexium 62 ILM Hardware Guide*.

Grounding the Robot

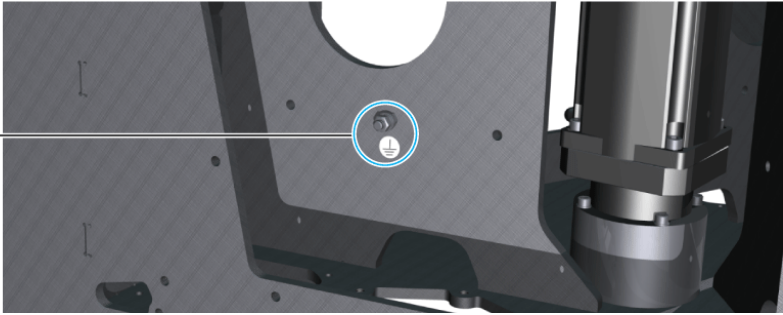
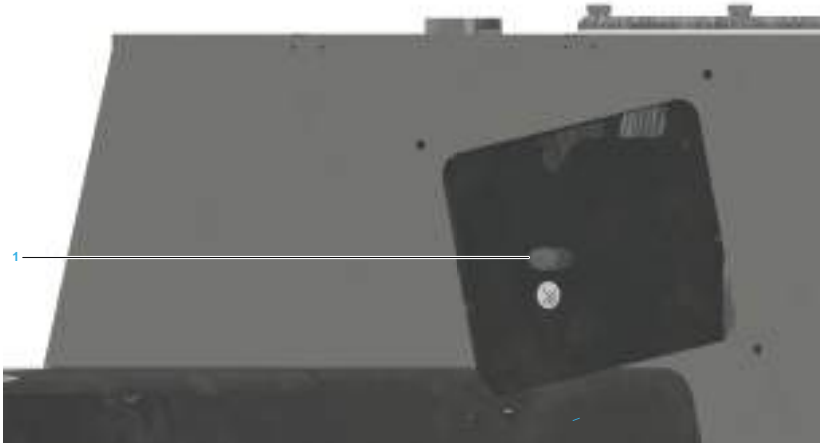
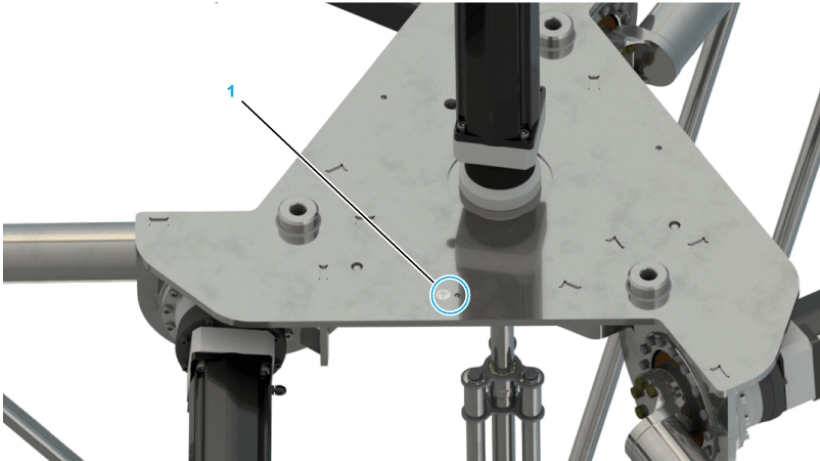
NOTE: When grounding the robot, use cables that comply with the applicable local standards, for example, cables that conform to NEC 70 / NFPA 79 in the USA.

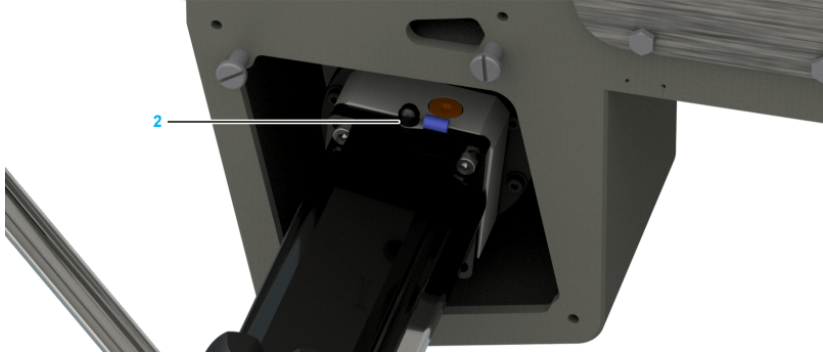
Step	Action
1	<p data-bbox="614 174 1437 226">Feed and fasten the ground cable (protective earth ground) to the ground connection (1) of the robot housing. The ground connections are marked with the following symbol:</p>  <p data-bbox="614 327 1123 360">VRKP...WD / VRKP...NO / VRKP...CW</p>  <p data-bbox="614 734 770 768">VRKP...WF</p>  <p data-bbox="614 1290 767 1323">VRKP...NC</p> 

Step	Action
2	<p>Verify the correct routing and fastening of the preconnected ground connection between the motors (2) and the robot housing.</p> <p>Tightening torque: 2.5 Nm (22 lbf-in)</p>  <p>NOTE:</p> <ul style="list-style-type: none"> The graphic is an example for the position of the ground connection at a main axis motor. The external protective ground connection wiring is determined by a number of variables. See the important safety information at the end of this table.
3	<p>Only for VRKP•L0•WD / VRKP•L0•NO:</p> <p>Fasten the ground cable to the ground connection (3) of the Lexium 62 Distribution Box (IEC 60417 - 5019 symbol).</p> <p>Tightening torque: 3.5 Nm (31 lbf-in)</p> 
4	<p>Only for robots with a motorized module:</p> <p>Ground the motorized module according to the cabling instructions of the respective module:</p> <ul style="list-style-type: none"> Cabling the Rotational Modules, page 160 Cabling the Rotational Tilting Modules, page 188 Cabling the Double Rotational Modules, page 177 Cabling the Tilting Modules, page 168
5	<p>Verify the correct routing and fastening of the cables to help prevent any collision of cables and moving parts.</p>

⚡ ⚠ DANGER

ELECTRIC SHOCK DUE TO IMPROPER GROUNDING

- Ground robot components in accordance with local, regional and/or national standards and regulations at a single, central point.
- Verify that the motors are connected to the central ground.

Failure to follow these instructions will result in death or serious injury.

Multipoint grounding is permissible if connections are made to an equipotential ground plane dimensioned to help avoid cable shield damage in the event of power system short-circuit currents.

Closing the Robot

⚡⚠ DANGER
HAZARD OF ELECTRIC SHOCK, EXPLOSION, OR ARC FLASH
<ul style="list-style-type: none"> • Only use the sealing washers supplied. • Only use stainless screws. • Tighten the screws with the specified tightening torques in order to produce electric conductivity between the cover and the housing. • Verify that all motor supply cables are permanently connected to the motors before closing the housing.
Failure to follow these instructions will result in death or serious injury.

NOTICE
LOSS OF IP65 DEGREE OF PROTECTION
Replace each sealing gasket every time you remove the maintenance cover(s).
Failure to follow these instructions can result in equipment damage.

Step	Action
1	<p>Mount all the maintenance covers (1) including the seal to the robot.</p> <p>Tightening torque: 6 Nm (53 lbf-in)</p>  <p>NOTE: For transportation, the maintenance covers are loosely bolted with a few screws for a fast assembly. The screws and washers necessary for mounting are located among the small parts supplied in the interior of the housing.</p> <p>For information on screws and washers, refer to the respective detail drawing in <i>Mechanical and Electrical Data</i>, page 31.</p>
2	Hook the motor cover seal (2) to the capture screws of the housing.
3	Hook the motor covers (4) on the capture screws (3) and ensure that the seals are positioned correctly. A motor cover protrusion of approximately 3 mm (0.118 in) is intended.

Step	Action
4	<p>Tighten the four threaded rods at the rear end of each motor cover (5).</p> <p>Tightening torque: 6 Nm (53 lbf-in)</p> 
5	<p>Tighten all the screws of the media covers on the upper and the bottom side of the robot.</p> <p>Tightening torque: 6 Nm (53 lbf-in)</p>

Reducing Risks Around the Robot

Step	Action
1	<p>Install external safety-related devices in accordance to local regulations and standards.</p>
2	<p>When designing the safety-related devices, assume that the robot cannot be stopped by internal logic and must be stopped by the external safety-related devices.</p> <p>NOTE: More information about the circuitry of emergency stop and additional protection elements is contained in the document <i>Lexium 52 Hardware Guide</i>, <i>Lexium 62 Hardware Guide</i>, or <i>Lexium 62 ILM Hardware Guide</i>.</p>
3	<p>Only for VRKP4L0R:</p> <p>If necessary, mount an ILM62-DIO8 module on the rotational axis drive.</p> <p>NOTE: After assembling a DIO8 module, the performance can be affected due to decreased heat dissipation and possible overheating.</p>

Initial Start-Up

Allocation of the Sercos Addresses

Presentation

Allocate the Sercos addresses of the servo amplifiers on the three main axes in ascending order and in counterclockwise direction.

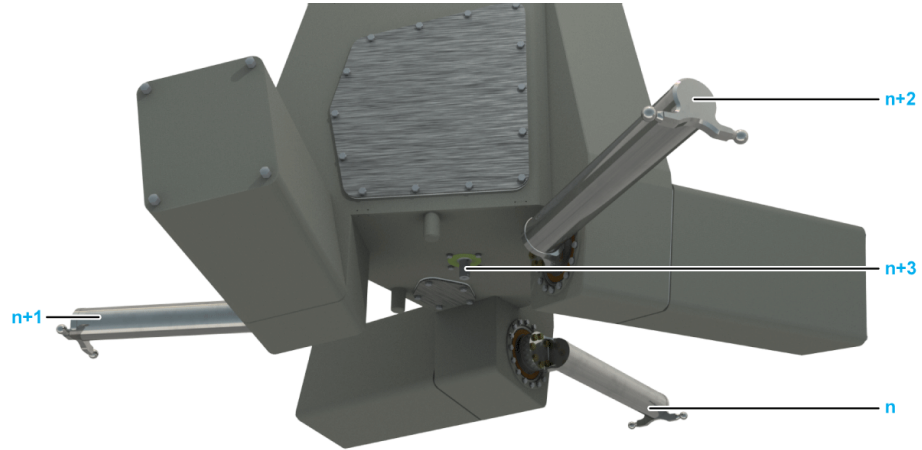

Parametrization of the Robot Mechanics

Parametrization of the Robot Mechanics by Means of the SchneiderElectricRobotics Library

Use the `SchneiderElectricRobotics` library for operating the Lexium P robot. The `SchneiderElectricRobotics` library facilitates the parametrization and increases the possible payload, the accuracy, and the performance of the system.

For further information about using the `SchneiderElectricRobotics` library, refer to *SchneiderElectricRobotics Library Guide* in the EcoStruxure Machine Expert online help.

Manual Parametrization of the Robot Mechanics

Depending on the application, individual values may or must be adapted or optimized. This must be effected relative to the payload, path, permissible tracking deviation, and other relevant parameters.

Verifying the Calibration and Motor Direction

Procedure Overview

Perform the following steps to verify the calibration and motor direction:

- Verifying the calibration, page 129
- Verifying the motor direction of rotation, page 130
- Moving the upper arms to mounting position, page 130

Verifying the Calibration

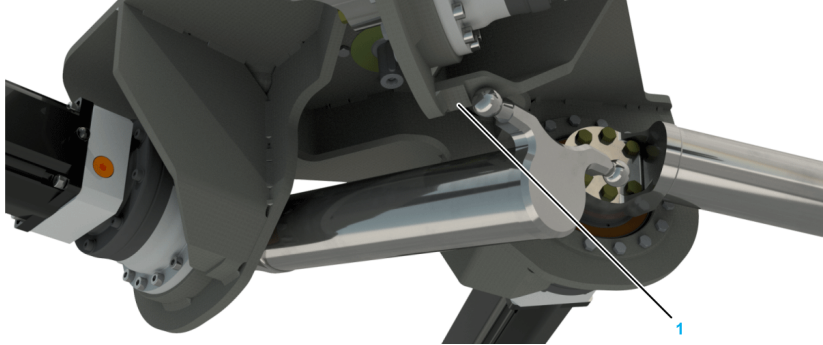
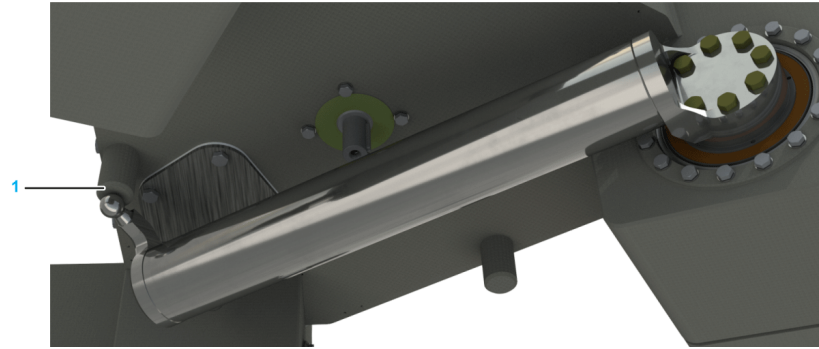
Step	Action
1	Open the brakes.
2	<p>Carefully rotate an upper arm inwards until one ball pin contacts the limit stop on the underside of the housing (1).</p> <p>The following figure shows the upper arm of robot VRKP1/VRKP2 at the calibration position:</p>  <p>The following figure shows the upper arm of the robot VRKP0/VRKP4/VRKP5/VRKP6 at the calibration position:</p>  <p>For further information, refer to <i>Calibration of the Robot Mechanics</i>, page 228.</p>
3	<p>Verify that the angle indicated corresponds to the following value:</p> <ul style="list-style-type: none"> • For VRKP0: -187.3° ($\pm 0.1^{\circ}$) • For VRKP1: -166.7° ($\pm 0.1^{\circ}$) • For VRKP2•••WD: -164.0° ($\pm 0.1^{\circ}$) • For VRKP2•••NC: -164.9° ($\pm 0.1^{\circ}$) • For VRKP4: -184.5° ($\pm 0.1^{\circ}$) • For VRKP5: -183.2° ($\pm 0.1^{\circ}$) • For VRKP6: -183.6° ($\pm 0.1^{\circ}$)
4	Move the arm outwards again until it is in a horizontal position (motor position $\sim 0^{\circ}$).
5	Repeat the process for all upper arms.

Verifying the Motor Direction of Rotation

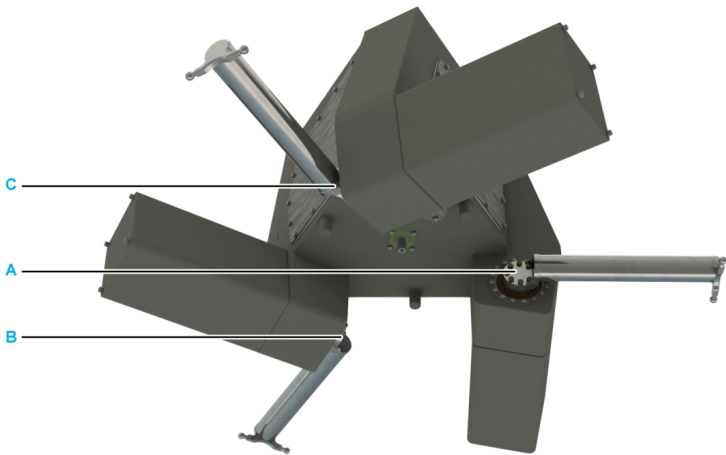
Step	Action
1	Slowly move the upper arms in manual mode, upwards and downwards. NOTE: Upwards (mathematically) is a positive change of an angle and downwards (mathematically) is a negative change of an angle.
2	Verify that the direction of rotation is correct.
3	Verify that the parameterized motor moves and the motors A, B, C are arranged in a counterclockwise position. 

For further information, refer to *Allocation of the Sercos Addresses*, page 128.

Moving the Upper Arms to Mounting Position

Step	Action
1	Slowly move the upper arms in manual mode to the mounting position for mounting the telescopic axis and the lower arms as shown in the following figure. 

Mounting the Telescopic Axis on Robots with a Rotational Axis

⚠️⚠️ DANGER

ELECTRIC SHOCK, EXPLOSION, OR ARC FLASH

- Disconnect all power from all equipment including connected devices prior to removing any covers or doors, or installing or removing any accessories, hardware, cables, or wires except under the specific conditions specified in the appropriate hardware guide for this equipment.
- Always use a properly rated voltage sensing device to confirm the power is off where and when indicated.
- Operate electrical components only with a connected protective ground (earth) cable.
- Verify the secure connection of the protective ground (earth) cable to all electrical devices to ensure that connection complies with the connection diagram.
- Do not touch the electrical connection points of the components when the module is energized.
- Provide protection against indirect contact.
- Insulate any unused conductors on both ends of the motor cable.

Failure to follow these instructions will result in death or serious injury.

NOTICE

INSUFFICIENT PART CLEARANCE

Ensure that the universal joint does not touch the gearbox seal during assembly.

Failure to follow these instructions can result in equipment damage.

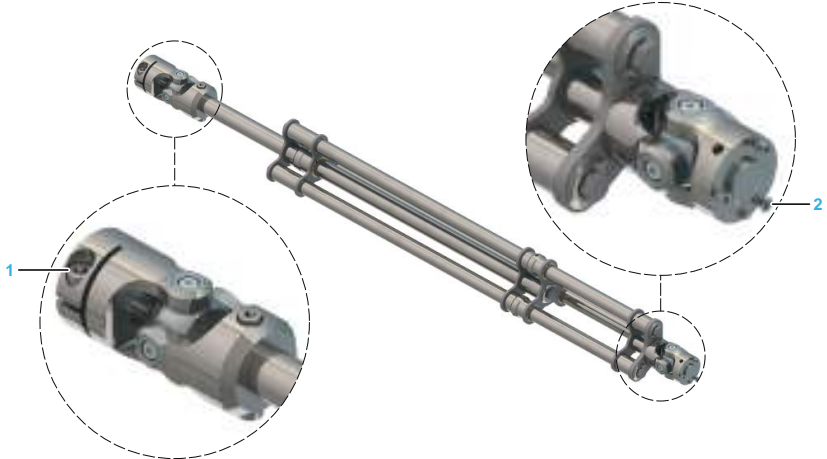
Step	Action
1	<p>Extend the telescopic axis to its entire length, then retract the same and verify whether it is easy to operate or whether some resistance occurs.</p> <p>NOTE: A light irregular resistance is normal and caused by the manufacturing tolerances of the tubes. The axis is run in during the first 100 hours of operation.</p>
2	<p>Loosen the clamping screw (1) at the top universal joint.</p> 
3	<p>Remove the three countersunk screws (2) from the underside of the bottom universal joint.</p>

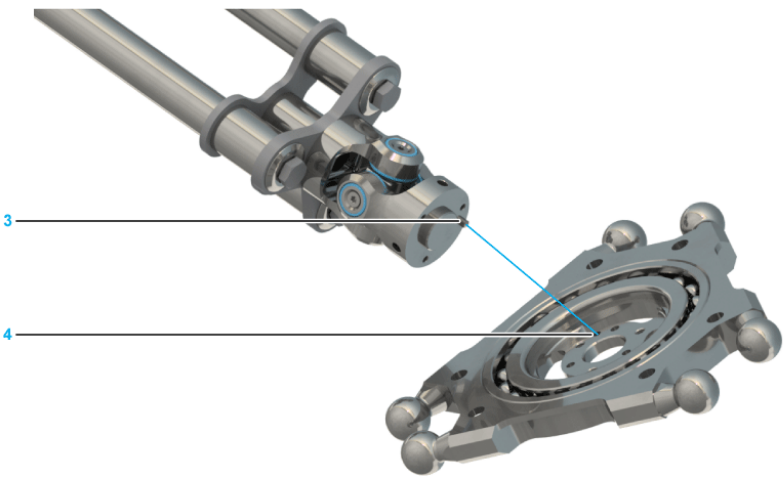
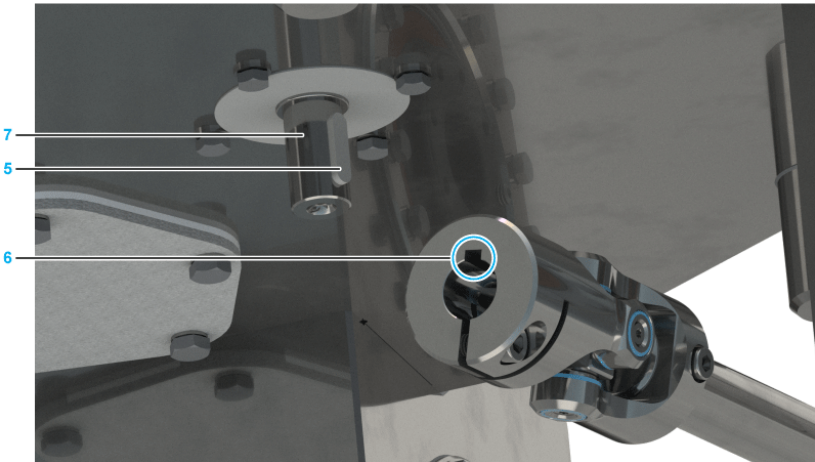
Step	Action
4	<p>Place the parallel plate on the bottom universal joint as shown in the following figure and ensure that the locating pin (3) is in alignment with the corresponding hole of the parallel plate (4).</p>  <p>NOTE: In the delivery condition, the index pin is located in the universal joint of the telescopic axis. During dismounting, it may be located in the parallel plate.</p>
5	<p>Attach the parallel plate to the universal joint by using the three countersunk screws that were removed previously. Use the high strength retaining compound Loctite 648 for this purpose.</p> <p>Tightening torque: 1 Nm (8.9 lbf-in)</p> <p>NOTE: Apply the high strength retaining compound Loctite 648 into the tapped holes as opposed to applying it to the screws.</p>
6	<p>Push the universal joint (6) over the shaft (7) protruding from the robot housing until the universal joint comes into its stop position on the gear shaft flange. In doing so, rotate the universal joint to ensure that the recess in the universal joint is located above the keyway (5).</p> 
7	<p>Tighten the clamping screw (1) that was loosened previously.</p> <p>Tightening torque: 7.4 Nm (65 lbf-in)</p>

Mounting the Lower Arms

Overview

DANGER

ELECTRIC SHOCK, EXPLOSION, OR ARC FLASH

- Disconnect all power from all equipment including connected devices prior to removing any covers or doors, or installing or removing any accessories, hardware, cables, or wires except under the specific conditions specified in the appropriate hardware guide for this equipment.
- Always use a properly rated voltage sensing device to confirm the power is off where and when indicated.
- Operate electrical components only with a connected protective ground (earth) cable.
- Verify the secure connection of the protective ground (earth) cable to all electrical devices to ensure that connection complies with the connection diagram.
- Do not touch the electrical connection points of the components when the module is energized.
- Provide protection against indirect contact.
- Insulate any unused conductors on both ends of the motor cable.

Failure to follow these instructions will result in death or serious injury.

The lower arms can be damaged if they are mounted incorrectly and then pulled apart.

NOTICE

INCORRECT MOUNTING OF LOWER ARMS

Always hold the lower arms at the level of the lower arm heads to pull them apart.

Failure to follow these instructions can result in equipment damage.

Procedure Overview

Perform the following steps to mount the lower arms:

- Assembling the lower arms, page 134
- Verifying the springs, page 134
- Hooking in the lower arms, page 134

Assembling the Lower Arms

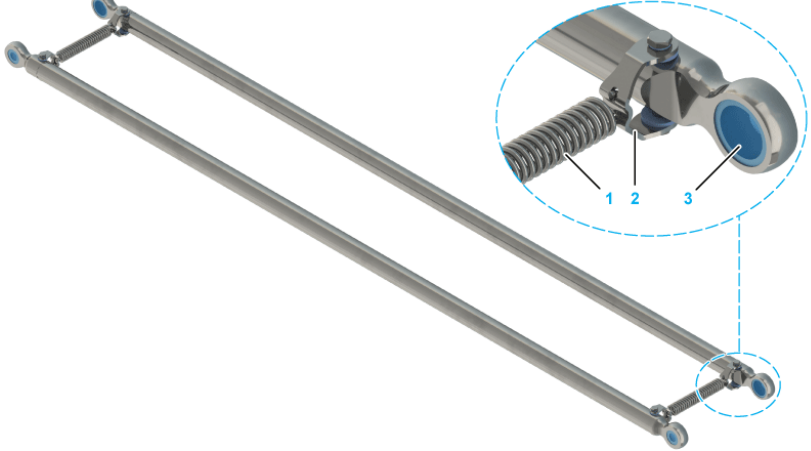
Step	Action
1	Verify that the lower arms show no visible signs of transport damage. If there are visible signs of transport damage, replace the lower arms, page 214.
2	<p>Pull the springs (1) across the spring brackets (2) located on the lower arms and connect each of the two lower arms to form a lower arm pair.</p> 
3	Use the figure above to verify the correct alignment of the lower arm heads and the ball sockets (3).
4	Attach a total of two springs per lower arm pair, one at the lower end, one at the upper end.

Verifying the Springs

Verify that the spring windings are in contact with one another when they are completely contracted (no load condition). If the spring windings are not in contact, replace them.

Hooking in the Lower Arms

NOTICE

OVERSTRETCHING OF THE SPRINGS

- Never pull the springs further apart than necessary to pull the lower arm over the second ball pin of the upper arm.
- Avoid pulling the arms apart and simultaneously across both ball pins.
- Replace springs after exceeding the elastic limit of the springs (overstretch).

Failure to follow these instructions can result in equipment damage.

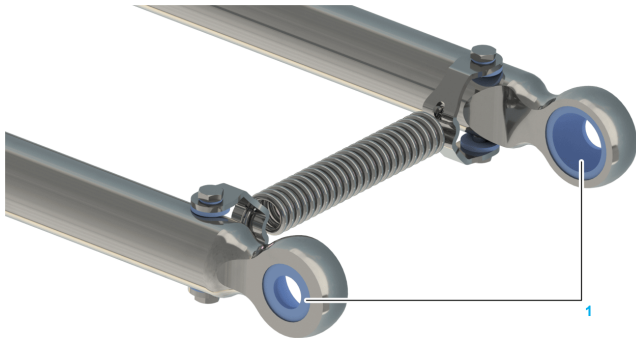
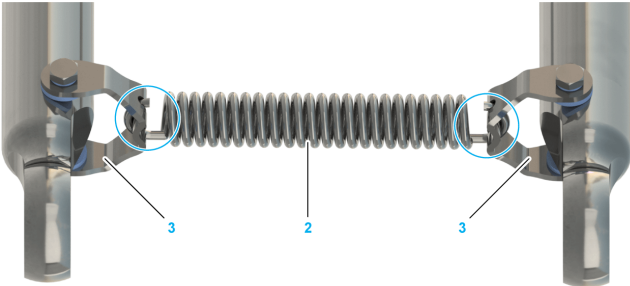
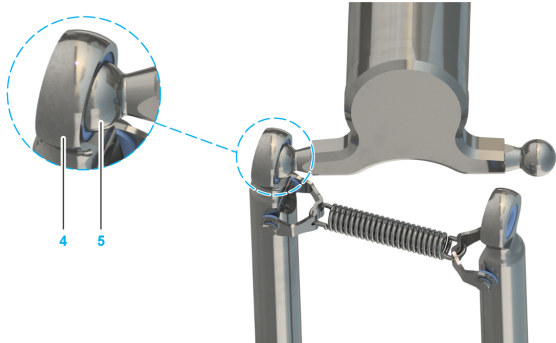
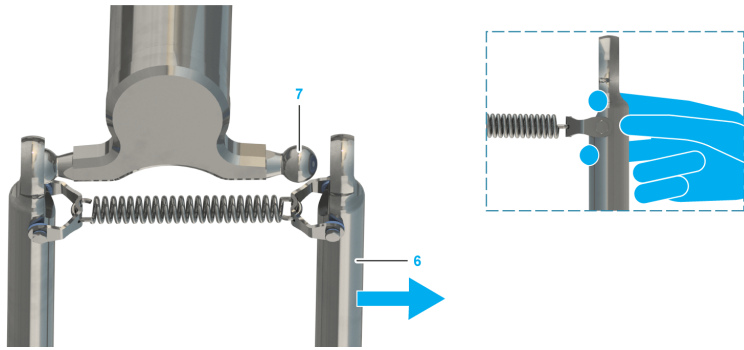
Step	Action
1	<p>Verify that the ball sockets (1) are located in each lower arm head.</p> 
2	<p>Verify that the springs (2) are embedded in the spring brackets (3).</p> 
3	<p>Pull a lower arm head (4) over a ball pin (5) of the upper arm.</p> 
4	<p>Pull the arm apart against the force of the spring in order to pull the lower arm (6) over the second ball pin (7) of the upper arm.</p>  <p>NOTE: Only touch the upper arm at its end and slightly rotate the aperture of the lower arm head in the direction of the ball pin.</p>

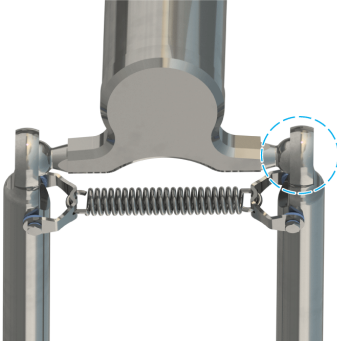
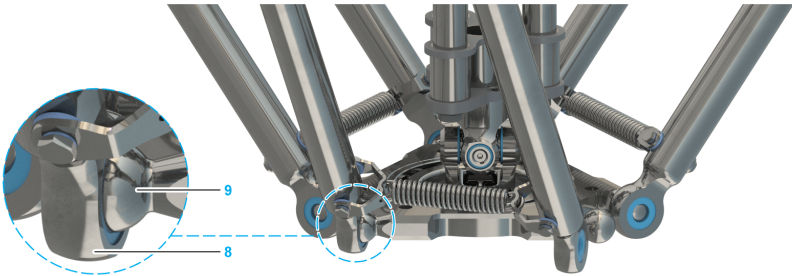
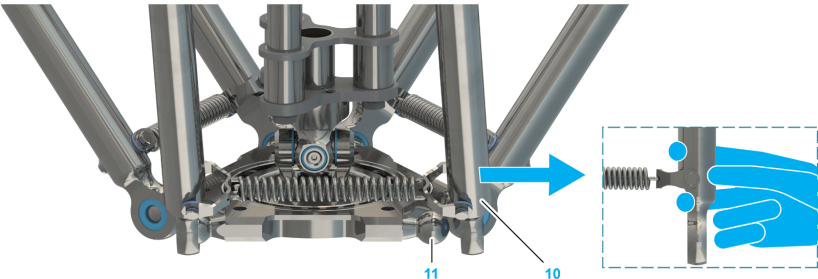
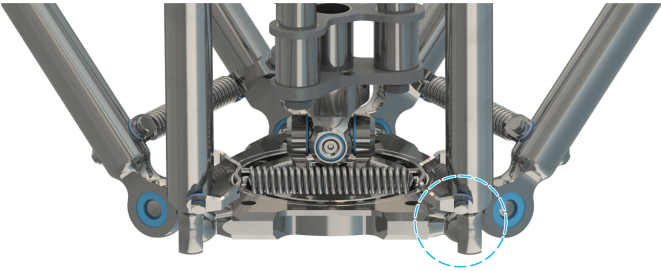
Step	Action
5	<p>Position the aperture of the lower arm on the ball pin.</p>  <p>Result: The lower arm is hooked on the upper arm.</p>
6	<p>Pull a lower arm head (8) over a ball pin (9) of the parallel plate.</p>  <p>NOTE: For robots with motorized modules, use the module instead of the parallel plate. Refer to: Mounting the Module on Robots with Motorized Modules, page 137.</p>
7	<p>Pull the arm apart against the force of the spring in order to pull the lower arm (10) over the second ball pin (11) of the upper arm.</p>  <p>NOTE: Only touch the upper arm at its ends as shown in the small graphic and slightly rotate the aperture of the lower arm head in the direction of the ball pin.</p>
8	<p>Position the aperture of the lower arm on the ball pin.</p>  <p>Result: The lower arm is hooked on the parallel plate.</p>
9	<p>Repeat the process for all lower arms.</p>

Mounting the Module on Robots with Motorized Modules

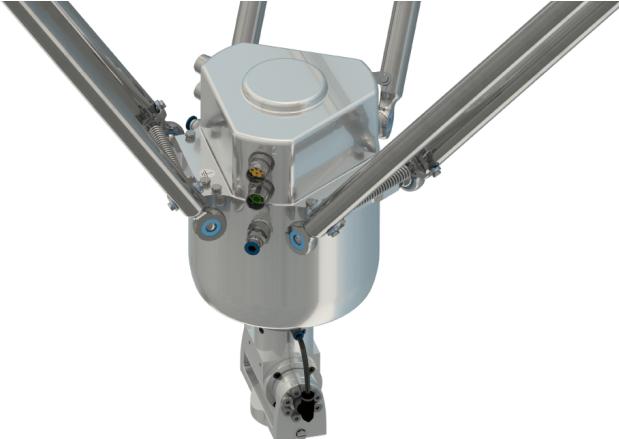
Step	Action
1	<p>Mount the module with the lower arms. When hooking in the module, ensure that the mounting for the gripper is located on the underside, as shown in the figure below.</p> <p>NOTE: The Rotational Module, the Tilting Module, the Double Rotational Module, and the Rotational Tilting Module can be rotated by $n \times 120^\circ$. Mount the respective module in its original position. See important information below this table.</p> 
2	Move the module slowly and verify the position of the gripper.

Mounting the module in other than the original position will lead to inaccurate positioning.

NOTICE
DAMAGE DUE TO INCORRECT POSITIONING
Verify that the mounting position of the module is consistent with the original position.
Failure to follow these instructions can result in equipment damage.

Verifying the Coordinate System of the Robot

Step	Action
1	Slowly move the robot in manual mode in the direction of an axis of the coordinate system.
2	Verify that the robot moves in a straight line in the direction of the axis.
3	<p>Verify that the robot moves in a straight line in a positive or negative direction of the coordinate system.</p> <p>NOTE: Arm of axis A is the cartesian coordinate X if coordinate system is not rotated by transformations variable <code>i_lrRotationAngle</code>.</p>
4	Repeat the process for all axes of the coordinate system.

In case the robot does not move in a straight line on the path, proceed as follows:

Step	Action
1	Select the robot type when using the <code>SchneiderElectricRobotics</code> library.
2	When not using the <code>SchneiderElectricRobotics</code> library, verify the correct parameterization of the transformation and the axes.
3	Verify the calibration, page 129.
4	Verify the direction of rotation of all drives, page 130.
5	Calibrate the robot if required, page 228.

In case the robot moves along a straight line but not in the direction of the required coordinate system, proceed as follows:

Step	Action
1	Verify the definition of the coordinate system on the transformation.
2	Verify the definition of the motors in the correct sequence, page 130.

Setting the Monitoring

Operating Library

Use the `SchneiderElectricRobotics` and `RoboticModule` library for operating the Lexium P robots.

Software Limits for Working Space

For the definition of application-specific software limits, refer to EcoStruxure Machine Expert online help.

Verifying the Brake Voltage

Verify the brake voltage as an incorrect voltage may cause premature wear of the brakes.

For further information, observe the respective operating instructions of the motors:

- VRKP0S0 / VRKP1S0 / VRKP2S0 / VRKP4S0 / VRKP5S0 / VRKP6S0: *SH3 Servo motor Motor Manual*
For the rotational axis motor of VRKP0 / VRKP1: *MH3 Servo motor Motor Manual*
- VRKP2L0 / VRKP4L0 / VRKP5L0 / VRKP6L0: *Lexium 62 ILM Hardware Guide*

Testing the Additional Protective Devices

- Verify the emergency stop, operator protective device, and device for releasing the brakes.
- Comply with the relevant standards, design the protective devices to stop the robot without leaving the path (Safe Stop 1 (SS1)).

For further information, refer to *Lexium 52 Hardware Guide* or *Lexium 62 Hardware Guide*.

Verifying the Monitoring

- Slowly move the robot beyond the limits of the preset working space in order to verify that this is prevented by the preset monitoring.
- Individually move the arms beyond the maximum/minimum angles in order to verify that this is prevented by the preset monitoring.

Start-Up

Overview

When the robot is operated for the first time, there is a risk of unintended equipment operation caused by possible wiring errors, improper mounting and fastening, or unsuitable parameters.

▲ WARNING
<p>UNINTENDED EQUIPMENT OPERATION</p> <ul style="list-style-type: none"> • Verify that the robot is properly and firmly fastened. • Take all necessary measures to ensure that the moving parts of the robot cannot move in an unanticipated way. • Verify that emergency stop equipment is operational and within reach of the zone of operation. • Verify that the system is obstacle-free and ready for the movement before starting the system. • Run initial tests at reduced velocity. <p>Failure to follow these instructions can result in death, serious injury, or equipment damage.</p>

If the motor power supply is disabled unintentionally, for example as a result of power outage, errors or functions, the motor is no longer decelerated in a controlled way.

▲ WARNING
<p>UNINTENDED EQUIPMENT OPERATION</p> <p>Verify that movements without braking effect cannot cause injuries or equipment damage.</p> <p>Failure to follow these instructions can result in death, serious injury, or equipment damage.</p>

The metal surfaces of the robot may exceed 70 °C (158 °F) during operation.

▲ WARNING
<p>HOT SURFACES</p> <ul style="list-style-type: none"> • Avoid unprotected contact with hot surfaces. • Do not allow flammable or heat-sensitive parts in the immediate vicinity of hot surfaces. • Verify that the heat dissipation is sufficient by performing a test run under maximum load conditions. <p>Failure to follow these instructions can result in death, serious injury, or equipment damage.</p>

For further information, refer to *Hot Surfaces*, page 17.

NOTE: Perform a start-up for an already configured robot when using the robot under modified operating conditions. For further information, refer to *Hazard Information*, page 12.

Commissioning Procedure

Step	Action
1	Verify the calibration and motor direction, page 128 and verify the coordinate system, page 137.
2	Comply with the instructions provided in the manual of the motor used and in the manual of the drives used.
3	Verify that the load conforms to the specified payloads for the robot before operating the robot.
4	Limit the maximum torque of the motor in accordance with the maximum drive torque of the robot.

Step	Action
5	Perform initial tests at reduced velocity.
6	Verify that the ambient conditions, page 30 conform to the appropriate specified conditions for the robot.

Mounting the Payload

Mounting the Gripper

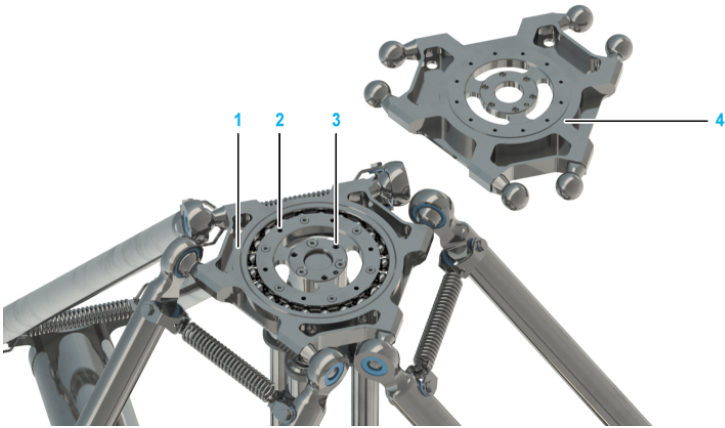
Step	Action
1	<p>Fasten the gripper to the mounting points provided for this purpose on the parallel plate (1) for robots with a rotational axis:</p> <ul style="list-style-type: none"> • Pitch circle diameter 61 mm (2.4 in): 6 x M2.5 (2), tightening torque: 0.5 Nm (4.4 lbf-in), strength class of the screw: at least A2-70 • Pitch circle diameter 28 mm (1.1 in): 3 x M4 (3), tightening torque: 1.8 Nm (16 lbf-in), strength class of the screw: at least A4-80 <p>For further information, refer to <i>Flange Dimensions for Robots with Three Axes</i>, page 141 or <i>Flange Dimensions for Robots with a Rotational Axis</i>, page 142.</p>  <p>NOTE: The mounting points on the parallel plate for robots without a rotational axis (4) are identical, but doubled.</p>
2	<p>Calibrate the rotational axis if this has not yet been done before the mounting of the gripper.</p> <p>NOTE:</p> <ul style="list-style-type: none"> • Observe the permissible weights and distances that result in the maximum tilting torque. • Maximum tilting torque on the bearing of the parallel plate for robots with a rotational axis: 20 Nm (177 lbf-in).

NOTE: A mounted gripper may cover the ball pin path of the open hybrid ball bearing. Cleaning could be constrained, this may lead to hygienic problems, or raised rotational torques of the bearing by collecting dirt inside the ball bearing. Keep the ball pin path free in order to allow the bearing to be flushed through from the top.

Flange Dimensions for Robots without a Rotational Axis

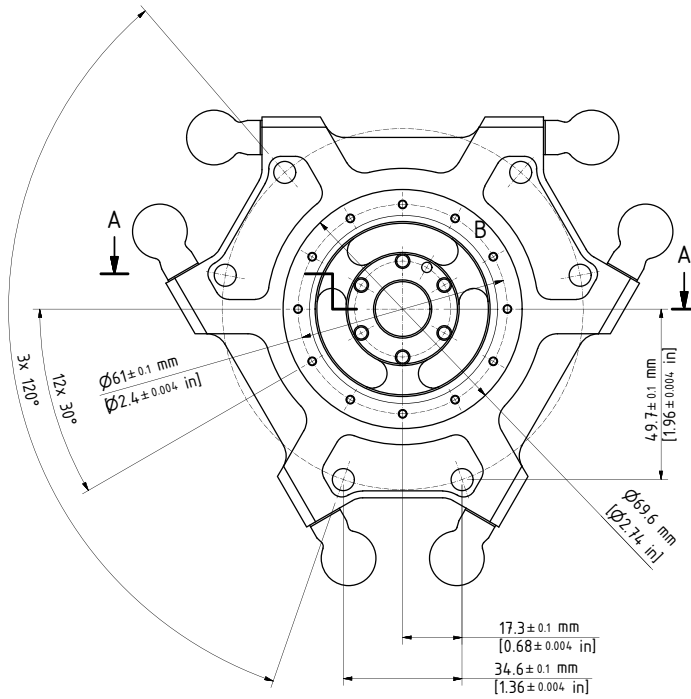

C (2 : 1)

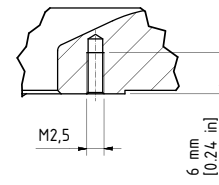

B (2 : 1)

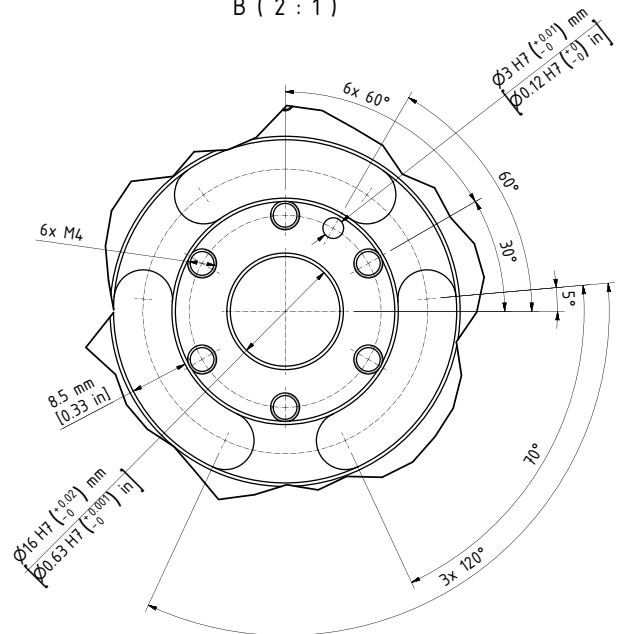

A-A (1 : 1)

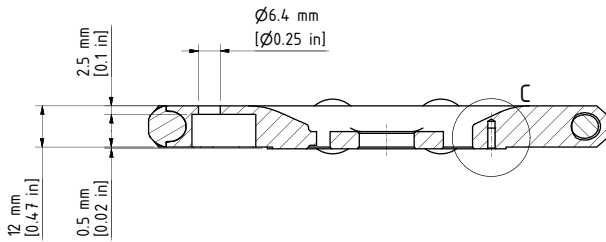

Bottom View (1 : 1)

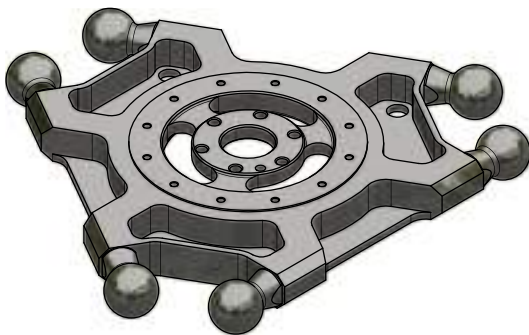

Top View (1 : 1)



Flange Dimensions for Robots with a Rotational Axis

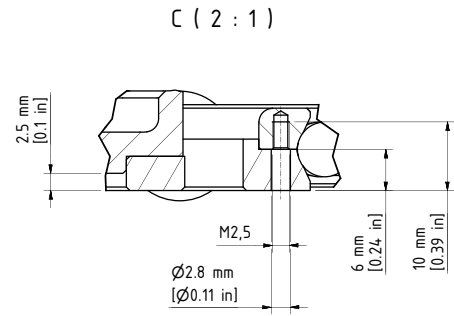
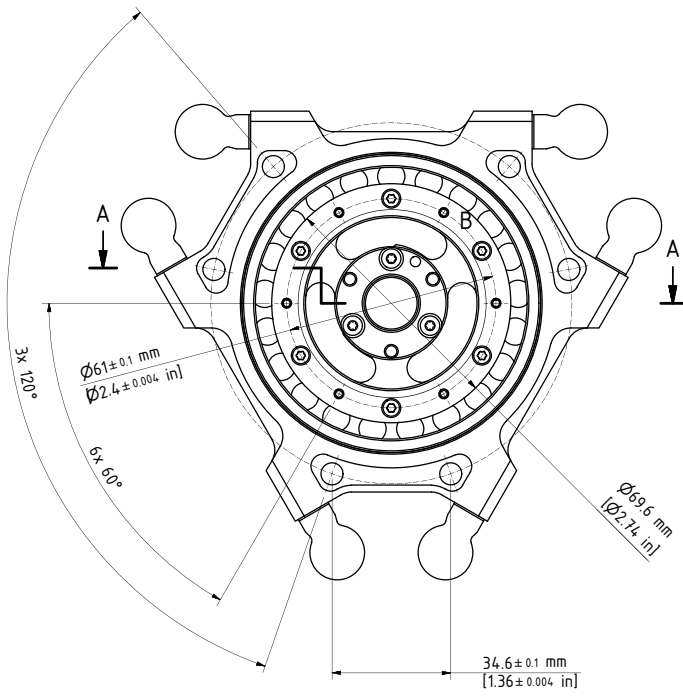

B (2 : 1)

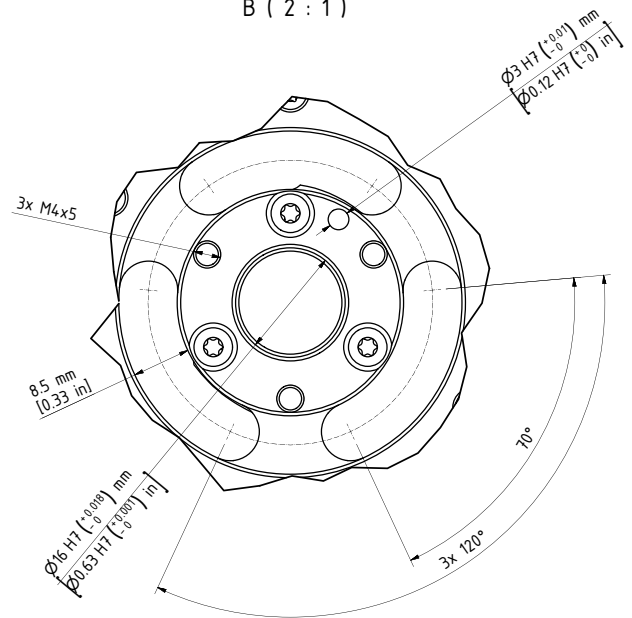

A-A (1 : 1)

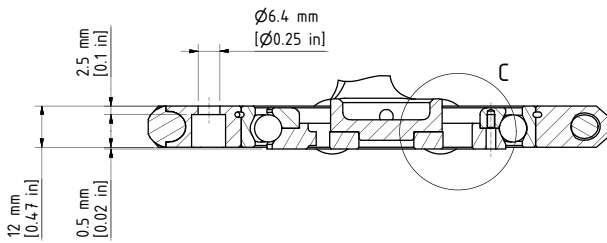

Bottom View (1 : 1)

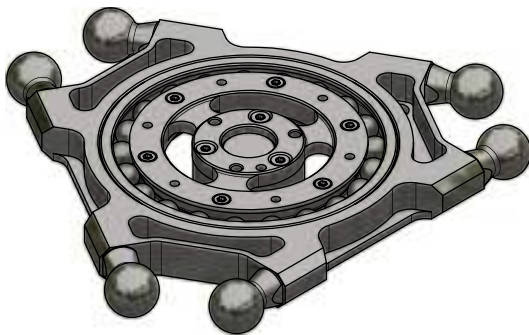

Top View (1 : 1)

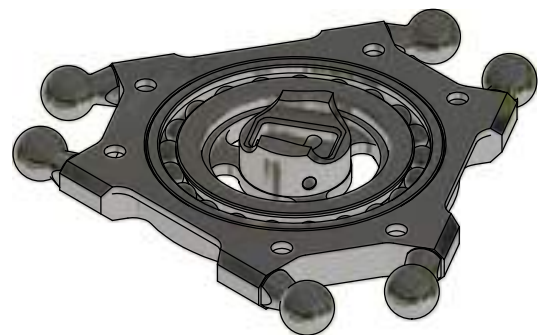

Supply of the Gripper

Feeding the Media from the Robot Housing

NOTICE

LOSS OF IP65 DEGREE OF PROTECTION

Replace each sealing gasket every time you remove the media cover.

Failure to follow these instructions can result in equipment damage.

In the case of Standard and Flat variants, incorrect pressure can damage or otherwise compromise the gearbox lubricants.

NOTICE

INOPERABLE GEARBOX DUE TO COMPROMISED LUBRICATION

You must ensure that the pressure inside of the robot does not exceed the maximum permissible overpressure of 100 kPa (0.1 bar (1.45 psi)) when assembling a valve terminal inside the robot.

Failure to follow these instructions can result in equipment damage.

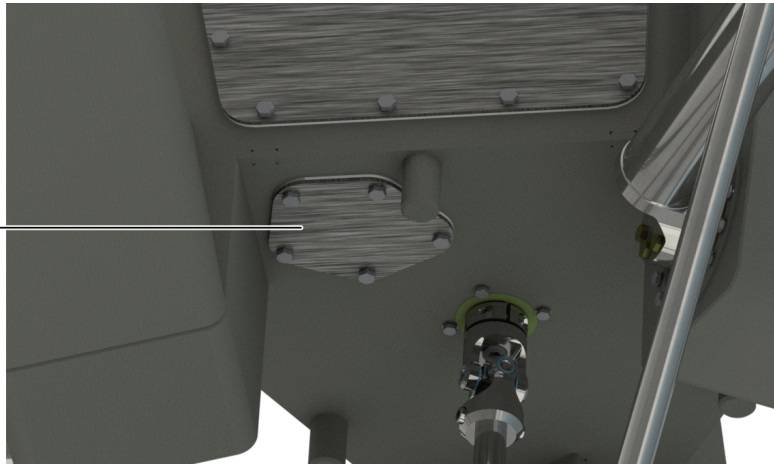
Step	Action
1	<p>Only for VRKP2...WD / VRKP4...WD / VRKP4...NO / VRKP4...CW / VRKP4...WF / VRKP5...WF / VRKP6...WF:</p> <p>Install parts of the media feed (for example, I/O module or valve terminal) in the interior of the robot.</p> <p>NOTE: In the delivery condition, the media cover does not have any openings.</p>
2	<p>Only for VRKP2...WD / VRKP4...WD / VRKP4...NO / VRKP4...CW / VRKP4...WF / VRKP5...WF / VRKP6...WF:</p> <p>Drill holes into the removed media cover for the media glands.</p>
3	<p>Feed in the media through the media cover (1) on the bottom side of the robot.</p> 
4	<p>Mount the media cover.</p> <p>Tightening torque: 6 Nm (53 lbf-in).</p>

Feeding the Media to the Gripper

⚠ WARNING

DAMAGED ARMS

Upper arms and lower arms must not be damaged by attaching additional media guide fasteners.

Failure to follow these instructions can result in death, serious injury, or equipment damage.

NOTICE

HIGH WEAR AND/OR DAMAGED SPRINGS

Distribute loads to lower arms in a way that minimizes the rotational forces on the arms.

Failure to follow these instructions can result in equipment damage.

Step	Action
1	<p>Feed in the media line from cables, hoses, and other media, via the upper and lower arms to the parallel plate.</p> <p>NOTE: Verify that the additional loads on the upper and lower arms are as small as possible. Distribute the additional loads to the different arms if possible. Attach the additional loads primarily to arms, which are not located in the robot main direction of motion. If possible, attach all additional loads to the lower arms to largely avoid damage to the arms due to dynamic forces. Arms must not be damaged by attaching additional media guide fasteners.</p>
2	<p>Feed in the media lines through the three apertures of the parallel plate to the gripper.</p> <div style="text-align: center;">  </div>

Optional Equipment

What's in This Chapter

Impact Plate.....	145
Gearbox Leakage Protection.....	146
Parallel Plate Ball Bearing Protection.....	148
Telescopic Axis Double.....	153
Rotational Modules.....	157
Tilting Modules.....	165
Double Rotational Modules.....	173
Rotational Tilting Modules.....	184

Impact Plate

Product Overview of the Impact Plate

Some applications require protection of the gearbox sealings of the main axes so that certain cleaning methods can be applied (for example, cleaning with water jet cleaning equipment). For such applications, you can apply the Lexium P Impact Plate to the main axes of the robots VRKP2, VRKP4, VRKP5, and VRKP6. For applying the Lexium P Impact Plate to the main axes of the robots VRKP0 and VRKP1, contact your local Schneider Electric service representative.

The following figure shows the Lexium P Impact Plate – VRKPXXXXXX00035.

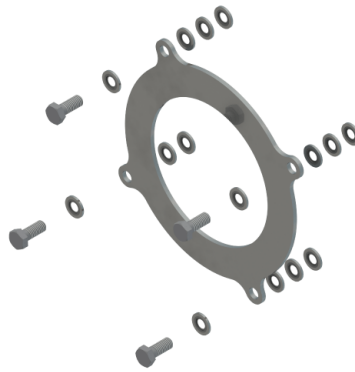

Mounting the Impact Plate

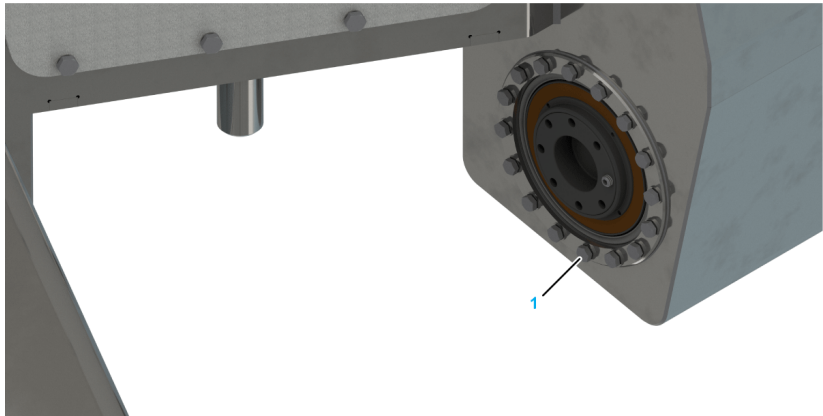
Step	Action
1	Remove the lower arms and the upper arms. For further information, refer to <i>Replacing the Lower Arms</i> , page 204 and <i>Replacing the Upper Arms</i> , page 218.
2	Remove four screws (1) at an angle of 90° from each of the three housing flanges. 

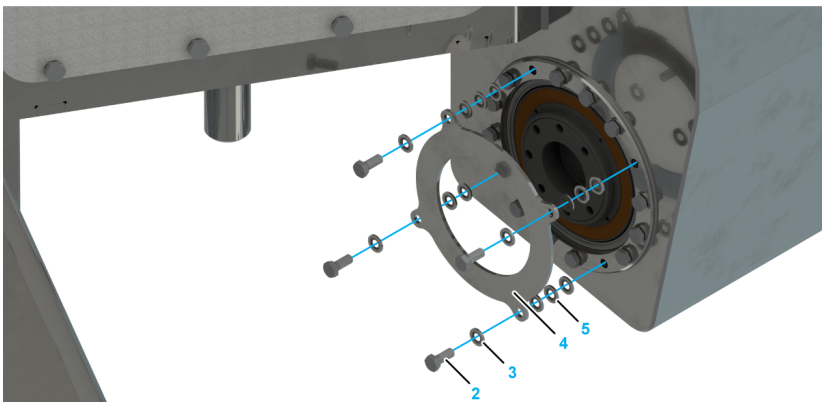
Step	Action
3	Place the Impact Plate (4) with three sealing washers (5) between the housing and the Impact Plate on each of the four holes. 
4	Fasten the Impact Plate with one screw (2) and one sealing washer (3) on each of the four holes. Tightening torque: 3.5 Nm (31 lbf-in)
5	Mount the upper arms and the lower arms. For further information, refer to <i>Replacing the Upper Arms</i> , page 218 and to <i>Mounting the Lower Arms</i> , page 133.
6	Calibrate the robot, page 228.

Gearbox Leakage Protection

Product Overview of the Gearbox Leakage Protection

In some applications, the customer end products that are handled by robots must not get contaminated or polluted by the lubricating oil. For such applications, you can additionally apply the Lexium P Gearbox Leakage Protection to the main axes motors of robots VRKP2, VRKP4, VRKP5, and VRKP6. For applying the Lexium P Gearbox Leakage Protection to the main axes of the robots VRKP0 and VRKP1, contact your local Schneider Electric service representative.

The following figure shows the Lexium P Gearbox Leakage Protection – VRKPXXXXXX00031.



NOTE: When mounting the Gearbox Leakage Protection to the main axes motors of robots in the flat variant (VRKP••••WF) or in the standard housing variant (VRKP••••WD / VRKP••••NO / VRKP••••CW), an extended motor cover (VRKPXXXXXX00036) must be used. For further information about the motor cover, refer to *Optional Equipment and Accessories*, page 244.

Mounting the Gearbox Leakage Protection

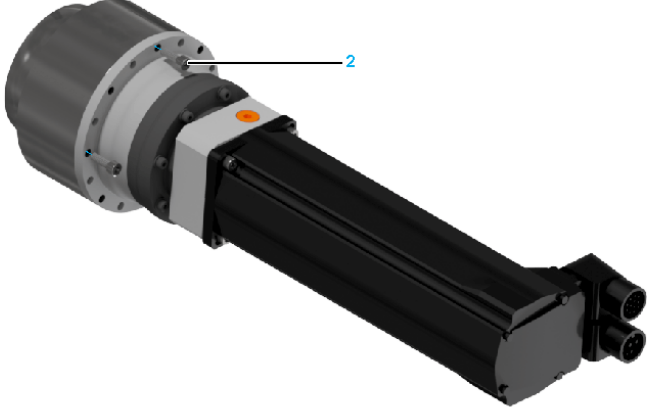
Step	Action
1	<p data-bbox="639 241 1342 271">Attach the output-flange extension to the gearbox with the eight screws (1).</p> <p data-bbox="639 286 986 315">Tightening torque: 14 Nm (124 lbf-in)</p> 
2	<p data-bbox="639 813 1358 842">Attach the protection box for the gearbox to the gearbox with four screws (2).</p> <p data-bbox="639 857 979 887">Tightening torque: 4.7 Nm (42 lbf-in)</p>  <p data-bbox="683 1379 1458 1451">NOTE: Verify the position of the O-rings while you are attaching the protection box for the gearbox to the gearbox. The O-rings are premounted and have to be in place during assembly.</p>

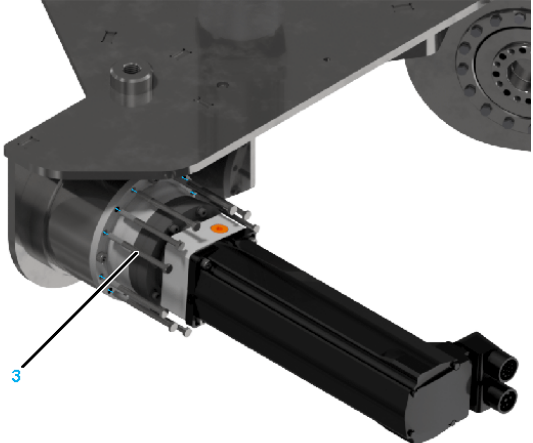
Step	Action
3	<p>Attach the unit (motor, gearbox, and Gearbox Leakage Protection) in the specified orientation to the robot housing with the twelve screws (3).</p> <p>Tightening torque: 4.7 Nm (42 lbf-in)</p>  <p>For further information about the specified orientation, refer to the respective detail drawing in <i>Mechanical and Electrical Data</i>, page 31.</p>
4	Clean the whole mounted unit.
5	Connect the motor as described in <i>Cabling the Motor and the Gearbox</i> , page 224.
6	Mount the upper arm as described in <i>Replacing the Upper Arms</i> , page 218.
7	Calibrate the robot mechanics, page 228.
8	Mount the motor cover, page 226

⚠ WARNING

COLLISION OF COMPONENTS

Calibrate the robot mechanics after the replacement of an upper arm, a motor, or a gearbox.

Failure to follow these instructions can result in death, serious injury, or equipment damage.

Parallel Plate Ball Bearing Protection

Product Overview of the Parallel Plate Ball Bearing Protection

For some applications in dry and dusty environments, the ball bearing of the parallel plate for robots with a rotational axis should be protected from dirt and dust. For such applications, you can additionally apply the Lexium P Parallel Plate Ball Bearing Protection to the parallel plate of Lexium P robots with a rotational axis.

The following figure shows the Lexium P Parallel Plate Ball Bearing Protection – VRKPXXXXXX00042.

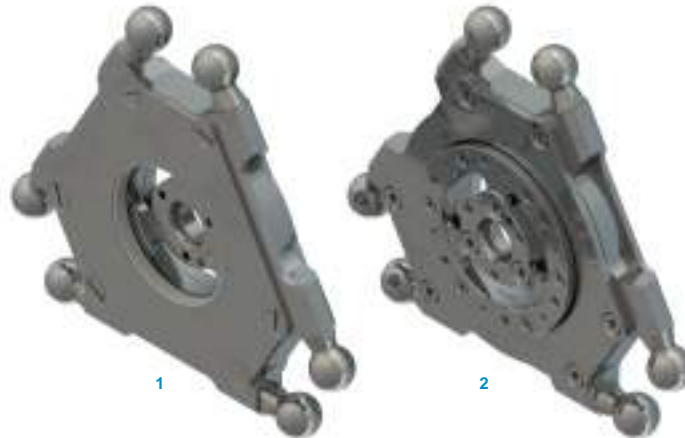



- 1 Top view
- 2 Bottom view

NOTE: When the Parallel Plate Ball Bearing Protection is mounted, the weight of the parallel plate increases. This may affect the performance of the robot.

Mounting the Parallel Plate Ball Bearing Protection

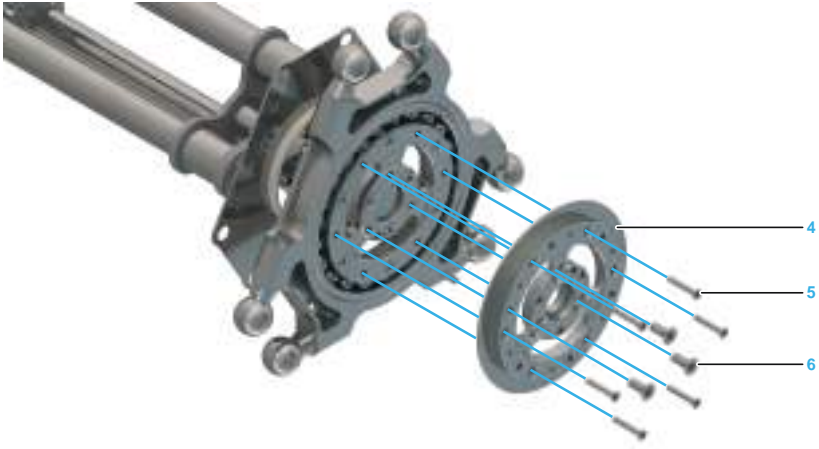
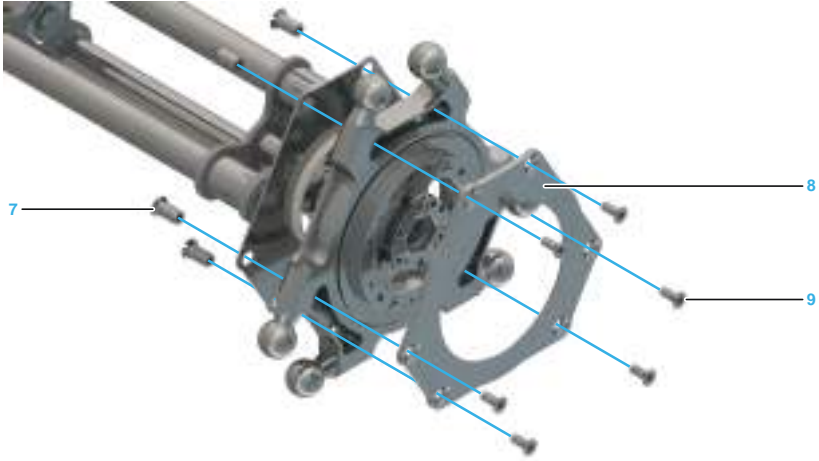
Step	Action
1	Remove the telescopic axis as described in <i>Replacing the Telescopic Axis</i> , page 204.
2	Remove the lower arms as described in <i>Replacing the Lower Arms</i> , page 214.
3	<p>Slide the cover top side (1) over the lower universal joint (2) of the telescopic axis and then attach the parallel plate (3) to the universal joint by using the three countersunk screws that were removed previously. Use the high strength retaining compound Loctite 648 for this purpose.</p> <p>Tightening torque: 1 Nm (8.9 lbf-in)</p> <p>NOTE: Apply the high strength retaining compound Loctite 648 into the tapped holes as opposed to applying it to the screws.</p>

Step	Action
4	<p>Fasten the flange offset ring (4) to the parallel plate with the three counter sunk screws M4x10 (6) and six counter sunk screws M2.5x16 (5). Use the medium strength threadlocking adhesive Loctite 243 for this purpose.</p> <p>Tightening torque:</p> <ul style="list-style-type: none"> • For M4x10: 1.8 Nm (15.9 lbf-in) • For M2.5x16: 0.5 Nm (4.43 lbf-in)"  <p>NOTE: Apply the medium strength threadlocking adhesive Loctite 243 into the tapped holes as opposed to applying it to the screws.</p>
5	<p>Insert the collar nuts (7) from above through the top cover and the six bores Ø6.4 of the parallel plate.</p> 
6	<p>Fasten the bottom cover (8) to the parallel plate with the six counter sunk screws M4x10 (9) and the collar nuts. Use the medium strength threadlocking adhesive Loctite 243 for this purpose.</p> <p>Tightening torque: 1.8 Nm (15.9 lbf-in)</p> <p>NOTE: Apply the medium strength threadlocking adhesive Loctite 243 into the tapped holes as opposed to applying it to the screws.</p>

Step	Action
7	<p>Check the ball bearing for ease of movement and grinding noises by rotating the parallel plate.</p>  <p>NOTE: The ball bearings should turn smoothly. There should be no grinding noises.</p>
8	<p>Mount the telescopic axis and the lower arms.</p> <p>For further information, refer to <i>Replacing the Telescopic Axis</i>, page 204 and <i>Replacing the Lower Arms</i>, page 214.</p>

Mounting the Gripper to the Parallel Plate Ball Bearing Protection

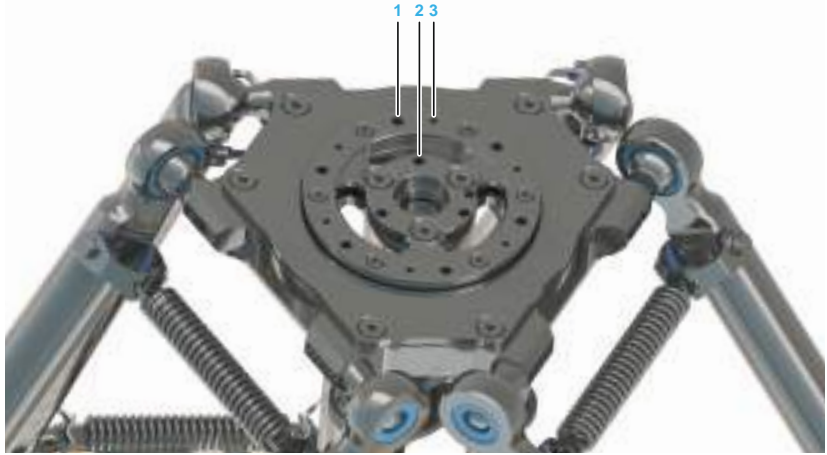
Step	Action
1	<p>Fasten the gripper to the mounting points provided for this purpose on the Parallel Plate Ball Bearing Protection:</p> <ul style="list-style-type: none"> • Pitch circle diameter 61 mm (2.4 in): 6 x M2.5 (1), tightening torque: 0.5 Nm (4.4 lbf-in), strength class of the screw: at least A2-70 • Pitch circle diameter 61 mm (2.4 in): 6 x M4 (2), tightening torque: 1.8 Nm (16 lbf-in), strength class of the screw: at least A2-70 • Pitch circle diameter 28 mm (1.1 in): 3 x M4 (3), tightening torque: 1.8 Nm (16 lbf-in), strength class of the screw: at least A4-80  <p>For further information, refer to <i>Flange Dimensions for Robots with a Rotational Axis and Parallel Plate Ball Bearing Protection</i>, page 152.</p>
2	<p>Calibrate the rotational axis if this has not yet been done before the mounting of the gripper.</p> <p>NOTE:</p> <ul style="list-style-type: none"> • Observe the permissible weights and distances that result in the maximum tilting torque. • Maximum tilting torque on the bearing of the parallel plate for robots with a rotational axis: 20 Nm (177 lbf-in).

Flange Dimensions for Robots with a Rotational Axis and Parallel Plate Ball Bearing Protection

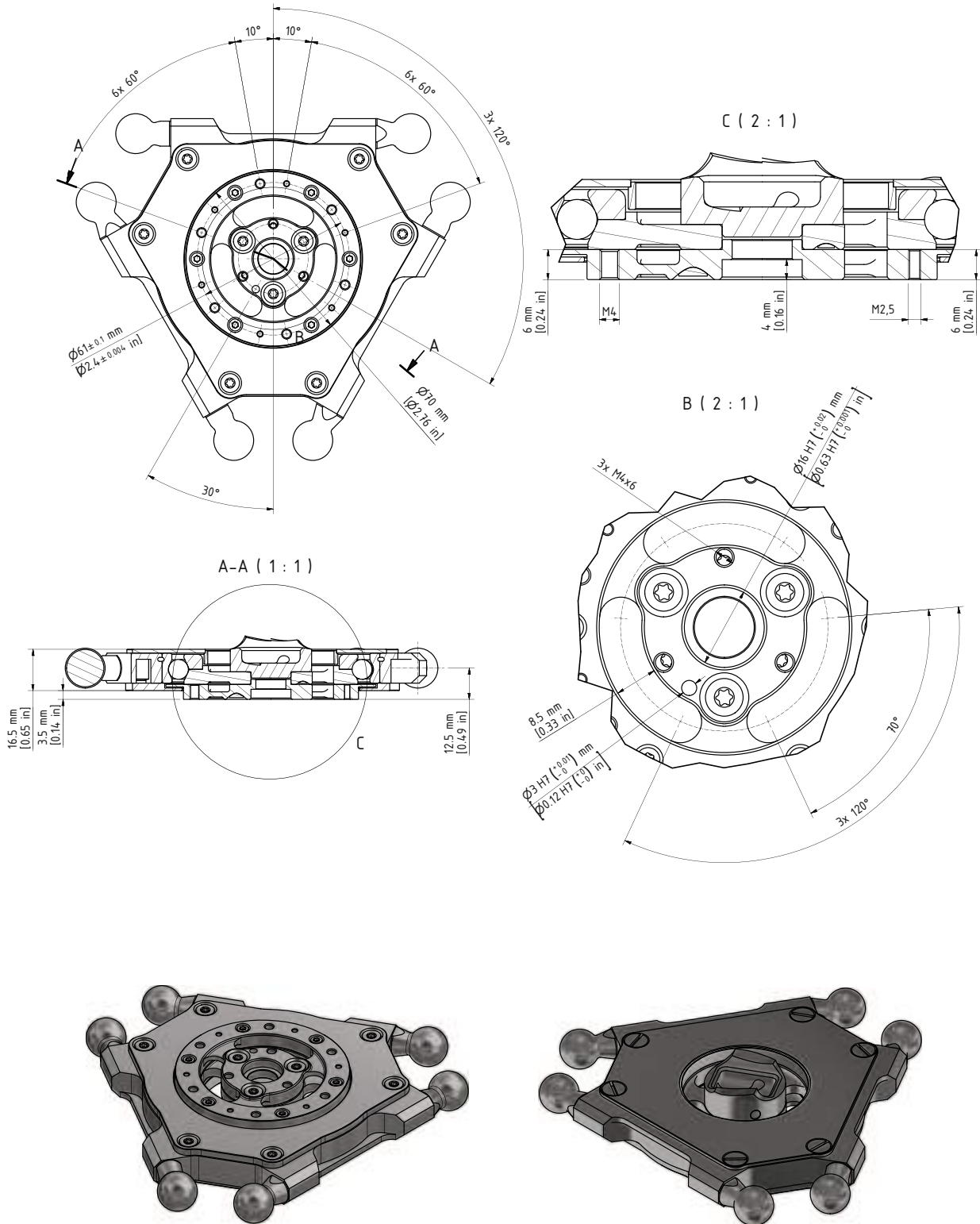

Telescopic Axis Double

Technical Data of the Telescopic Axis Double

Mechanical Data of the Telescopic Axis Double

Category	Parameter	Unit	VRKP- YYYYY00007
General data	Maximum torque of the rotational axis with the Telescopic Axis Double	Nm (lbf-in)	3 (26.6)

Dimension	Description	Unit	Robot type				
			VRKP2	VRKP4	VRKP5	VRKP6	VRKP6E00
A	Minimum length	mm (in)	458.4 (18)	610.4 (24)	686.4 (27)	766.4 (30)	842.4 (33)
B	Stroke	mm (in)	278.6 (11)	430.6 (17)	506.6 (20)	586.6 (23)	662.6 (26)

Mounting the Telescopic Axis Double

NOTICE
INSUFFICIENT PART CLEARANCE
Ensure that the universal joint does not touch the gearbox seal during assembly.
Failure to follow these instructions can result in equipment damage.

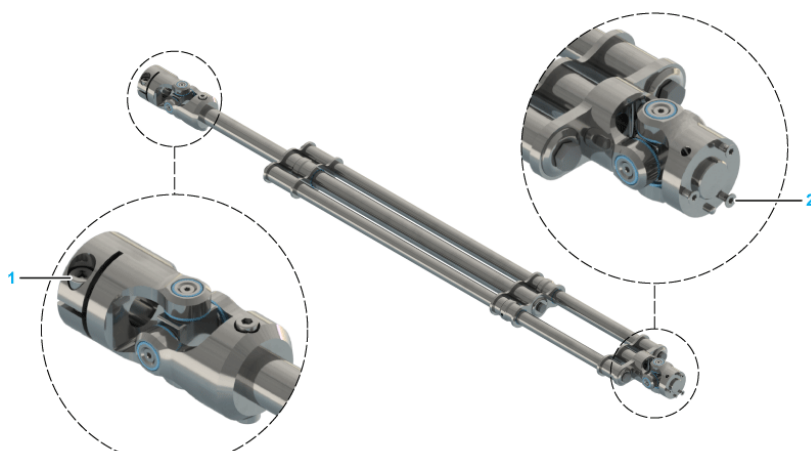
Step	Action
1	Extend the Telescopic Axis Double to its entire length, then retract the same and verify whether it is easy to operate or whether some resistance occurs. NOTE: A light irregular resistance is normal and caused by the manufacturing tolerances of the tubes. The axis is run in during the first 100 hours of operation.
2	Loosen the clamping screw (1) at the top universal joint. <div style="text-align: center;">  </div>
3	Remove the three countersunk screws in the underside of the bottom universal joint (2).

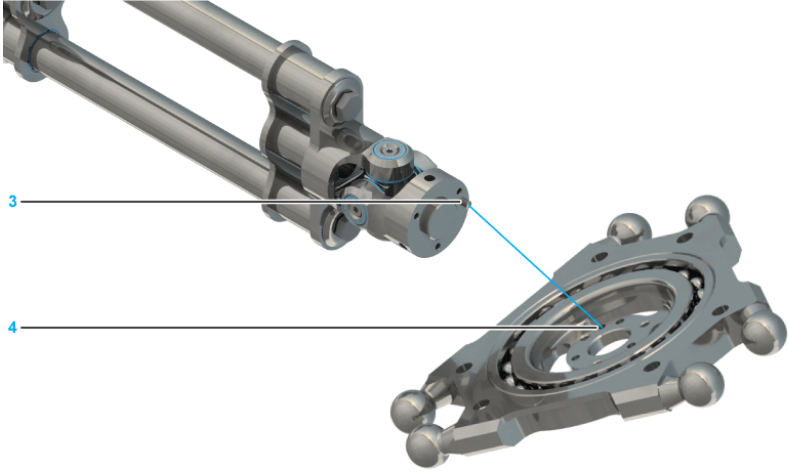
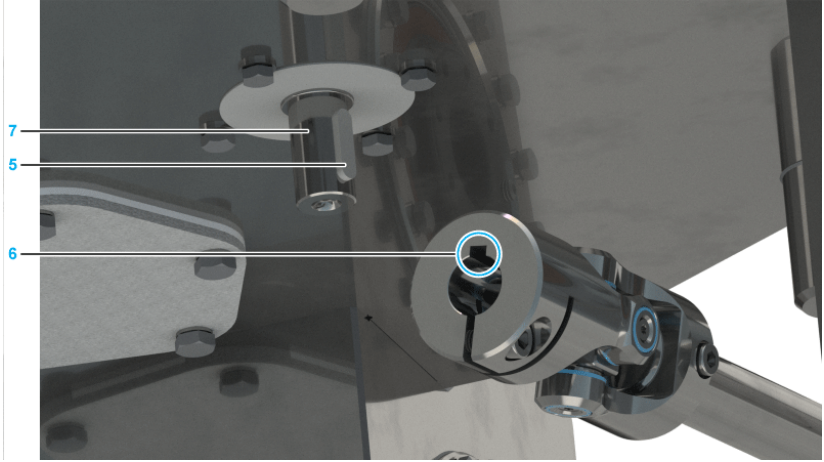
Step	Action
4	<p>Place the parallel plate on the bottom universal joint as shown in the following figure and ensure that the locating pin (3) is in alignment with the corresponding hole of the parallel plate (4).</p>  <p>NOTE: In the delivery condition, the index pin is located in the universal joint of the Telescopic Axis Double. During dismounting, it may be located in the parallel plate.</p>
5	<p>Attach the parallel plate to the universal joint by using the three countersunk screws that were removed previously. Use the high strength retaining compound Loctite 648 for this purpose.</p> <p>Tightening torque: 0.8 Nm (7.1 lbf-in)</p> <p>NOTE: Apply the high strength retaining compound Loctite 648 into the tapped holes as opposed to applying it to the screws.</p>
6	<p>Push the universal joint (6) over the shaft (7) protruding from the robot housing until the universal joint comes into its stop position on the gear shaft flange. In doing so, rotate the universal joint to ensure that the recess in the universal joint is located above the keyway (5).</p>  <p>NOTE: When using a plastic universal joint: as a result of frequent assembly and disassembly, the flange of the universal joint can be damaged so that the universal joint may touch the seal of the Telescopic Axis Double gearbox.</p>
7	<p>Tighten the clamping screw (1) that was loosened previously.</p> <p>Tightening torque: 4 Nm (35.4 lbf-in)</p>

Rotational Modules

Product Overview of the Rotational Modules

Overview

Some applications require the use of a rotational axis with an increased torque and/or a better position repeatability. For such applications, you can apply the Lexium P Rotational Module to the Lexium P Robot.

The following figure represents the Lexium P Rotational Module B – VRKPXXXXXX00045 and the Lexium P Rotational Module HT-B – VRKPXXXXXX00046.

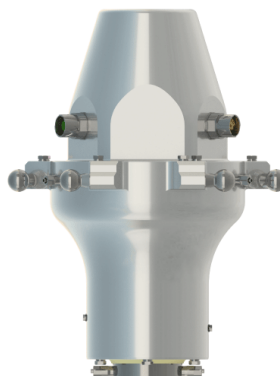

Type Plate of the Rotational Modules

The type plate of the Rotational Modules is provided in the packaging. You can attach the type plate next to the type plate of the robot, page 28.

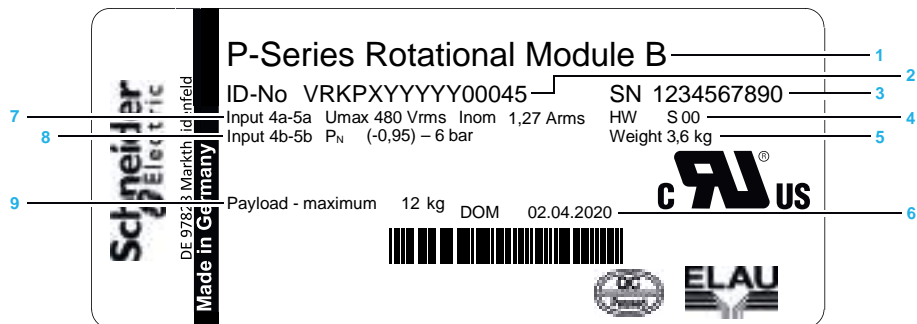

1	Device name
2	Type code
3	Serial number
4	Hardware code
5	Weight of the module

6	Date of manufacture
7	Voltage and current of the fourth and fifth axis
8	Maximum operating pressure
9	Maximum Load

Technical Data of the Rotational Modules

Mechanical and Electrical Data of the Rotational Modules

Category	Parameter	Unit	VRKPY YYY00045	VRKPY YYY00046
General data	Rated load	kg (lb)	1.5 (3.3)	5 (11)
	Maximum load ⁽¹⁾	kg (lb)	12 (33)	12 (33)
	Allocation of auxiliary axes	–	4th	
	Maximum torque of the 4th axis ⁽²⁾	Nm (lbf-in)	16 (142) ⁽³⁾	
	Nominal torque of the 4th axis ⁽²⁾	Nm (lbf-in)	4.5 (40)	12 (106)
	Position repeatability (ISO 9283)	–	Angle: +/-0.1°	
Electrical data	Mains voltage - 3-phase	Vac	480 ⁽⁴⁾	
	Control voltage (with brake)	Vdc	+24 (-10...+6%)	
	Motor 4th axis	–	SH30402P07F2000	
	Maximum current of 4th axis motor ⁽⁵⁾	A	4.10	1.54
Mechanical data	Protection class	–	IP65	
	Gear ratio i	–	15/1	40/1
	Drive parameter <i>GearOut</i>	–	15	40
	Drive parameter <i>GearIn</i>	–	1	
	Maximum speed	1/min	600	225
	Software parameter <i>TcpPlateSize</i>	mm (in)	75 (2.95) ⁽⁶⁾	
Pneumatic data	Number of pneumatic connections	–	2	
	Operating pressure	bar (psi)	-0.95...+6 (-13.8...+87)	
Working space	Rotation 4th axis	–	Unlimited	
Weight	–	kg (lb)	3.5 (7.7)	
Material	External casing	–	Aluminum, stainless steel 1.4301, steel nickel-plated, zinc nickel-plated, FPM, EPDM	
<p>(1) Loads above the maximum load are possible with restrictions. If required, contact your local Schneider Electric service representative.</p> <p>(2) When designing the gripper, be aware of any appearance of mass moments of inertia as well as friction, which could lead to exceeding the maximum torque and consequential damage.</p> <p>(3) For further information, refer to <i>Lexium 52 Hardware Guide</i> or <i>Lexium 62 Hardware Guide</i>.</p> <p>(4) Motor without brake.</p> <p>(5) Use the drive parameter <i>UserDrivePeakCurrent</i> to adjust the maximum current.</p> <p>(6) This value is the distance between the suspension points of the lower arms and the center of the flange plate.</p>				

Maximum Tilting Torque

The loading capacity of the Rotational Modules is limited by the maximum tilting torque at the ball pins level. The following diagram shows the possible vertical distance of the mass at its center of gravity of the payload to the FCP relative to the mass and the required maximum acceleration.

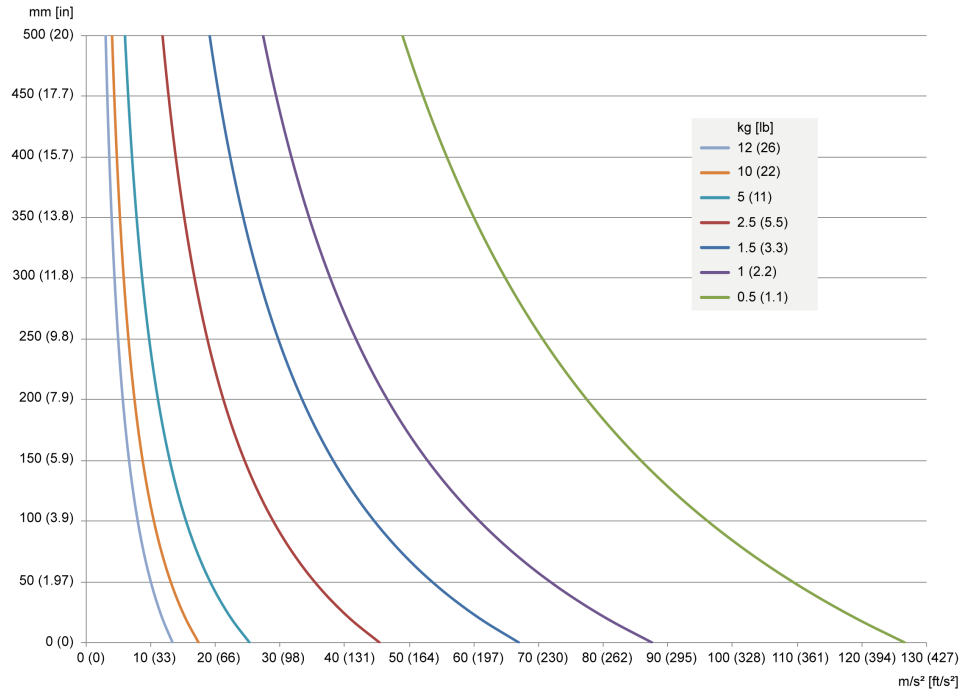

A maximum tilting torque of 20 Nm (177 lbf-in) is to be observed at the ball pins level.

Calculate the tilting torque with the following formula:

$$\text{Tilting torque [Nm (lbf-in)]} = \text{total payload [kg (lb)]} \times \text{maximum acceleration [m/s}^2 \text{ (ft/s}^2\text{)]} \times \text{vertical distance [m (in)]}$$

NOTE:

- Total payload [Nm (lbf-in)] = weight of the module + weight of the gripper + weight of the customer end product
- Vertical distance [m (in)] = distance from the ball pins level to the total mass center point = (weight of the module [kg (lb)] x vertical distance from the ball pins to the mass center point of the module (A) [m (in)] + weight of the gripper and the customer end product [kg (lb)] x (vertical distance from the FCP (flange center point) to the mass center point of the gripper and the customer end product (C) [m (in)] + vertical distance from the ball pins to the FCP (B) [m (in)])) / total payload [kg (lb)]

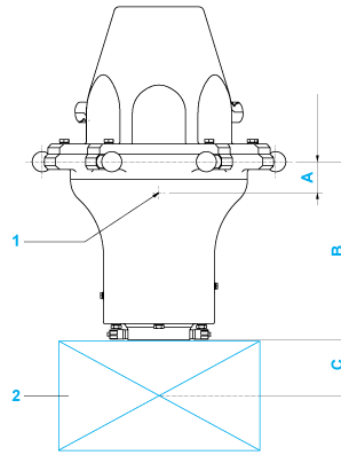

1 Mass center point of the module

2 Gripper and customer end product

Dimension	Description	Unit	VRKPXXXXXX00045	VRKPXXXXXX00046
A	Vertical distance from the ball pins to the mass center point of the module	mm (in)	25 (0.98)	25 (0.98)
B	Vertical distance from the ball pins to the FCP	mm (in)	141 (5.6)	141 (5.6)
C	Vertical distance from FCP to the mass center point of the gripper and the customer end product	mm (in)	Depends on the gripper and the customer end product	

Mounting the Rotational Modules

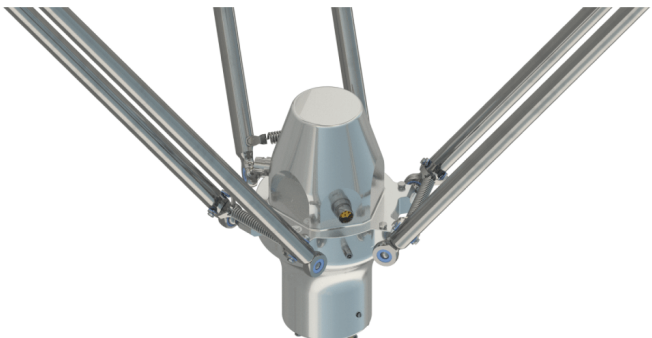
Step	Action
1	<p>Hook in the lower arms on the Rotational Module.</p> <p>For further information, refer to <i>Hooking in the Lower Arms</i>, page 134.</p> 

Cabling the Rotational Modules

Overview

For cabling the Rotational Module, use only Schneider Electric extension cables that are specifically designed for the robot application.

The following table presents the appropriate cable for each robot type.

Robot type	Cable length	Cable type	Order number
VRKP0	3 m (9.8 ft)	Encoder extension cable	VW3E2100R030
VRKP1		Power extension cable	VW3E1168R030
VRKP2			
VRKP4			
VRKP5	4.3 m (14 ft)	Encoder extension cable	VW3E2100R043
VRKP6		Power extension cable	VW3E1168R043

If other cable lengths are required, contact your local Schneider Electric service representative.

Cabling the Rotational Modules

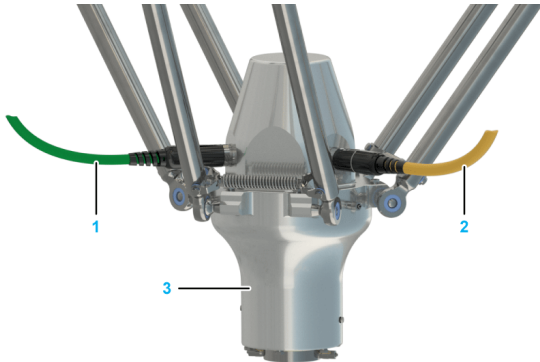
Step	Action
1	Feed one encoder cable for SH3040 motors to the middle of the robot housing.
2	Feed one power cable for SH3040 motors to the middle of the robot housing. NOTE: For equipment that you are supplying that is not described in the present document, consult the documentation for those products.
3	<p>Connect the encoder extension cable (VW3E2100R•••) (1) and the power extension cable (VW3E1168R•••) (2) to the Rotational Module (3) as described for the SH3040 motor in the <i>SH3 Servo motor Motor Manual</i>.</p>  <p>NOTE: For cabling the Rotational Module use only Schneider Electric extension cables that are specifically designed for the robot application.</p>
4	<p>Feed the encoder extension cable and the power extension cable from the Rotational Module via the lower and upper arms of the robot into the robot housing.</p> <p>NOTE:</p> <ul style="list-style-type: none"> • Attach the cables to the lower and upper arms so that the cables have sufficient freedom of movement to reach with the TCP all positions in the working space. • Consider the bending radius for the respective cables: <ul style="list-style-type: none"> ◦ VW3E1168R••• – minimum bending radius: 69 mm (2.7 in) ◦ VW3E2100R••• – minimum bending radius: 63 mm (2.5 in)

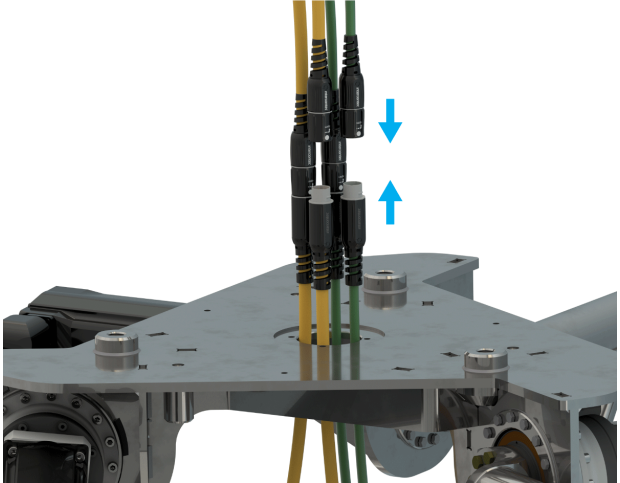
Step	Action
5	<p>Connect the cables in the robot housing with the cables from the Rotational Module.</p>  <p>NOTE: For the washdown robot references, contact your local Schneider Electric representative.</p>
6	<p>Verify the correct routing and fastening of the cables to help prevent any collision of cables and moving parts.</p>

NOTICE

INCORRECT PAIRING OF POWER AND ENCODER CABLES

Label the power and associated encoder cables according to their pairing.

Failure to follow these instructions can result in equipment damage.

Grounding Robots with the Rotational Module

Ground those parts of the robot which are located where either contact with current carrying parts (cables) or an insulation error is probable.

Alternatively, protect the cables with insulation which withstands the mechanical, chemical, electrical, and thermal stresses that it can be subjected to during normal operating conditions.

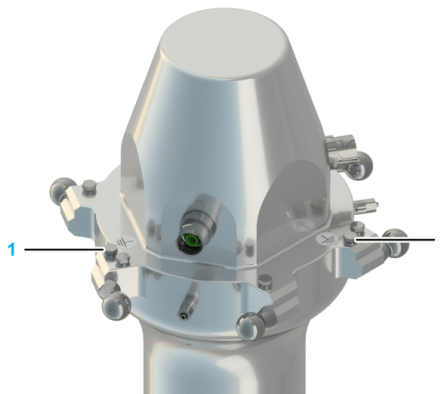

Ground the Rotational Module via one of the screws (1) for protective ground (earth) if grounding via the protective ground conductor of the motor cable is insufficient. To ensure an ideal electrical connection, use a serrated lock washer between the housing and cable lug. The tightening torque of the screws is 2 Nm (17.7 lbf-in).

⚠ ⚠ DANGER

ELECTRIC SHOCK DUE TO IMPROPER GROUNDING

- Ground robot components in accordance with local, regional and/or national standards and regulations at a single, central point.
- Verify that the motors are connected to the central ground.

Failure to follow these instructions will result in death or serious injury.

Mounting the Payload to the Rotational Modules

Overview

Here you will find the following information:

- Mounting the gripper to the Rotational Modules , page 163
- Flange dimensions for the Rotational Modules , page 164
- Supply of the gripper on the Rotational Modules, page 165

Mounting the Gripper to the Rotational Modules

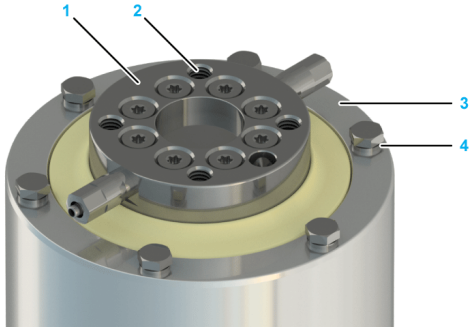
Step	Action
1	<p>Fasten the gripper to the mounting points at the rotating flange (1) or on the fixed flange (3):</p> <ul style="list-style-type: none"> • Pitch circle diameter DIN ISO 9409-1, 40 mm (1.57 in): 4 x M6 (2), tightening torque: 4.2 Nm (37 lbf-in), strength class of the screw: at least A2-70 • Pitch circle diameter 78 mm (3.07 in): 6 x M4 (4), tightening torque: 2 Nm (17.7 lbf-in), strength class of the screw: at least A2-70 <p>For further information, refer to <i>Flange Dimensions for the Rotational Modules</i>, page 164.</p> 
2	<p>Calibrate the Rotational Module if this has not been done before mounting the gripper.</p> <p>For further information, refer to <i>Calibrating the Double Rotational Module and the Rotational Tilting Module</i>, page 232.</p> <p>NOTE:</p> <ul style="list-style-type: none"> • Observe the permissible weights and distances that result in maximum tilting torque, page 159. • The maximum torque must not be exceeded. For the respective values, refer to <i>Mechanical and Electrical Data of the Rotational Modules</i>, page 158.

Supply of the Gripper on the Rotational Modules

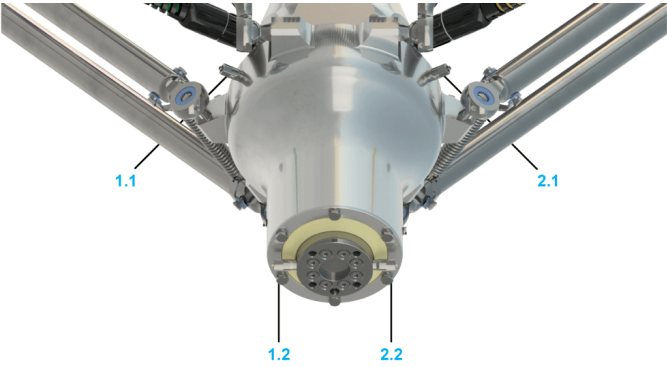
Step	Action
1	<p>Connect the media line to one of the pneumatic plug-in connections (1.1 or 2.1) of the Rotational Module. The plug-in connection has a diameter of 4 mm (0.0157 in).</p>  <p>For further information, refer to <i>Supply of the Gripper</i>, page 143.</p>
2	<p>Connect the media line of the gripper to one of the associated connections (1.2 or 2.2) on the rotational flange of the Rotational Module.</p> <p>Straight fitting diameter: 4 mm (0.157 in)</p> <p>NOTE:</p> <ul style="list-style-type: none"> • Connection 1.1 is linked to connection 1.2 • Connection 2.1 is linked to connection 2.2

Tilting Modules

Product Overview of the Tilting Modules

Overview

Some applications require the use of a tilting axis. For such applications, you can apply the Lexium P Tilting Module B or the Lexium P Tilting Module HT-B-HD to the Lexium P Robot.

The following figure shows the Lexium P Tilting Module B – VRKPXXXXXX00053.



The following figure shows the Lexium P Tilting Module HT-B-HD – VRKPYYYYYY00052.

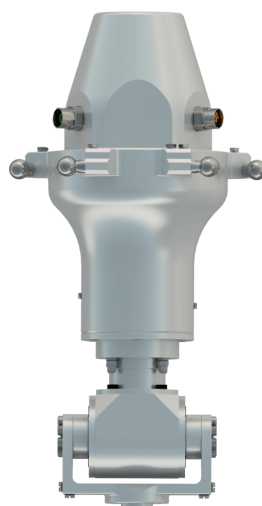

Type Plate of the Tilting Modules

The type plate of the Tilting Modules is provided in the packaging. You can attach the type plate next to the type plate of the robot.

The type plate design is the same as for the Rotational Module, page 157.

Technical Data of the Tilting Modules

Mechanical and Electrical Data of the Tilting Modules

Category	Parameter	Unit	VRKPYYYY YY00053	VRKPYYYY YY00052
General data	Maximum load without restrictions	kg (lb)	0.25 (0.55)	0.5 (1.1)
	Load with restrictions ⁽¹⁾	kg (lb)	0.25...2.5 (0.55...5.5)	0.5...5 (1.1... 11)
	Allocation of auxiliary axes	–	4th	
	Maximum torque of the 4th axis ⁽²⁾	Nm (lbf-in)	7.5 (66)	20 (177)
	Maximum holding torque of 4th motor	Nm (lbf-in)	5 (44)	20 (177)
	Position repeatability (ISO 9283)	–	Angle: +/-0.1°	
Electrical data	Mains voltage - 3-phase	Vac	480 ⁽³⁾	
	Control voltage (with brake)	Vdc	+24 (-10...+6%)	
	Motor 4th axis	–	SH30402P07F2000	
	Maximum current of 4th axis motor ⁽⁴⁾	A	1.9	0.9
Mechanical data	Protection class	–	IP65	
	Gear ratio <i>i</i>	–	15/1	80/1
	Drive parameter <i>GearOut</i>	–	15	80
	Drive parameter <i>GearIn</i>	–	1	
	Maximum speed	1/min	600	112.5
	Software parameter <i>TcpPlateSize</i>	mm (in)	75 (2.95) ⁽⁵⁾	
Pneumatic data	Number of pneumatic connections	–	0	
	Operating pressure	bar (psi)	–	
Working space	Tilting 4th axis	–	+/-100°	

Category	Parameter	Unit	VRKPYYY YY00053	VRKPYYY YY00052
Weight	–	kg (lb)	4.3 (9.5)	5 (11)
Material	External casing	–	Aluminum, stainless steel, steel nickel-plated, zinc nickel-plated, brass nickel-plated, FPM, EPDM	
<p>(1) Loads above the maximum load are possible with restrictions. If required, contact your local Schneider Electric service representative.</p> <p>(2) When designing the gripper, be aware of any appearance of mass moments of inertia as well as friction, which could lead to exceeding the maximum torque and consequential damage.</p> <p>(3) For further information, refer to <i>Lexium 52 Hardware Guide</i> or <i>Lexium 62 Hardware Guide</i>.</p> <p>(4) Use the drive parameter <i>UserDrivePeakCurrent</i> to adjust the maximum current.</p> <p>(5) This value is the distance between the suspension points of the lower arms and the center of the flange plate.</p>				

Maximum Tilting Torque

The loading capacity of the Tilting Modules is limited by the maximum tilting torque at the ball pins level.

A maximum tilting torque of 20 Nm (177 lbf-in) is to be observed at the ball pins level.

Calculate the tilting torque with the following formula:

$$\text{Tilting torque [Nm (lbf-in)]} = \text{total payload [kg (lb)]} \times \text{maximum acceleration [m/s}^2 \text{ (ft/s}^2\text{)]} \times \text{vertical distance [m (in)]}$$

NOTE:

- Total payload [Nm (lbf-in)] = weight of the module + weight of the gripper + weight of the customer end product
- Vertical distance [m (in)] = distance from the ball pins level to the total mass center point = (weight of the module [kg (lb)] x vertical distance from the ball pins to the mass center point of the module (A) [m (in)] + weight of the gripper and the customer end product [kg (lb)] x (vertical distance from the FCP (flange center point) to the mass center point of the gripper and the customer end product (C) [m (in)] + vertical distance from the ball pins to the FCP (B) [m (in)])) / total payload [kg (lb)]

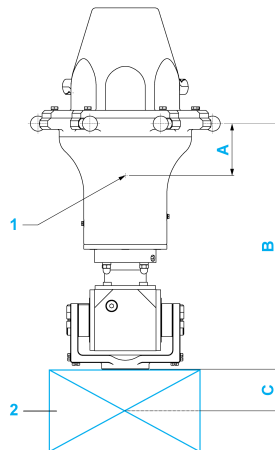

1 Mass center point of the module

2 Gripper and customer end product

Dimension	Description	Unit	Tilting Module B	Tilting Module HT-B-HD
A	Vertical distance from the ball pins to the mass center point of the module	mm (in)	54 (2.13)	55 (2.17)
B	Vertical distance from the ball pins to the FCP	mm (in)	228 (9)	264 (10.4)
C	Vertical distance from FCP to the mass center point of the gripper and the customer end product	mm (in)	Depends on the gripper and the customer end product	

Mounting the Tilting Modules

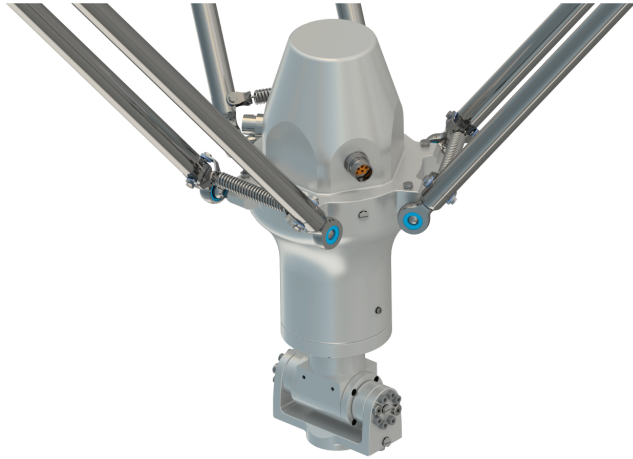
Step	Action
1	<p>Hook in the lower arms on the Tilting Module.</p> <p>For further information, refer to <i>Hooking in the Lower Arms</i>, page 134.</p> 

Cabling the Tilting Modules

The procedures for cabling and grounding the Tilting Modules are similar to the procedures for the Rotational Modules. Therefore, refer to *Cabling the Rotational Modules*, page 160 for further information.

Mounting the Payload to the Tilting Modules

Overview

Here you will find the following information:

- Mounting the gripper to the Tilting Module B, page 169
- Flange dimensions for the Tilting Module B, page 170
- Mounting the gripper to the Tilting Module HT-B-HD, page 171
- Flange dimensions for the Tilting Module HT-B-HD, page 172

Mounting the Gripper to the Tilting Module B

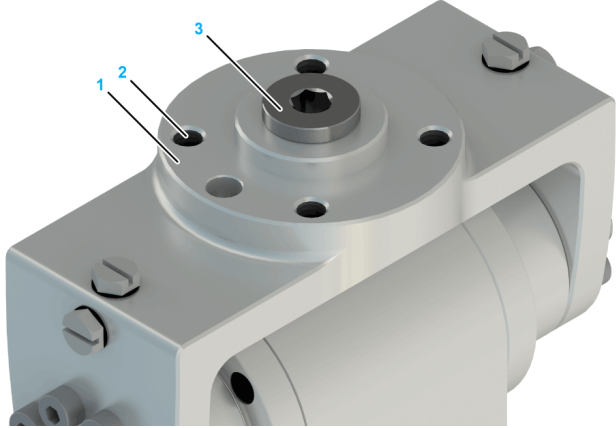
Step	Action
1	<p>Fasten the gripper to the mounting points at the flange (1):</p> <ul style="list-style-type: none"> • Pitch circle diameter DIN ISO 9409-1, 40 mm (1.57 in): 4 x M6 (2), tightening torque: 4.5 Nm (40 lbf-in), strength class of the screw: at least A2-70 • Thread for suction pads G1/4": G1/4" x 12 mm (G1/4" x 0.47 in) (3), tightening torque: depends on your gripper. Closed with a screw plug as standard. <p>For further information, refer to <i>Flange Dimensions for the Tilting Module B</i>, page 170.</p> <div style="text-align: center;">  </div>
2	<p>Calibrate the Tilting Module B if this has not been done before mounting the gripper. For further information, refer to <i>Calibrating the Tilting Module</i>, page 234.</p> <p>NOTE:</p> <ul style="list-style-type: none"> • Observe the permissible weights and distances that result in the <i>maximum tilting torque</i>, page 167. • The maximum torque must not be exceeded. For the respective values, refer to <i>Mechanical and Electrical Data of the Tilting Modules</i>, page 166.

Flange Dimensions for the Tilting Module B

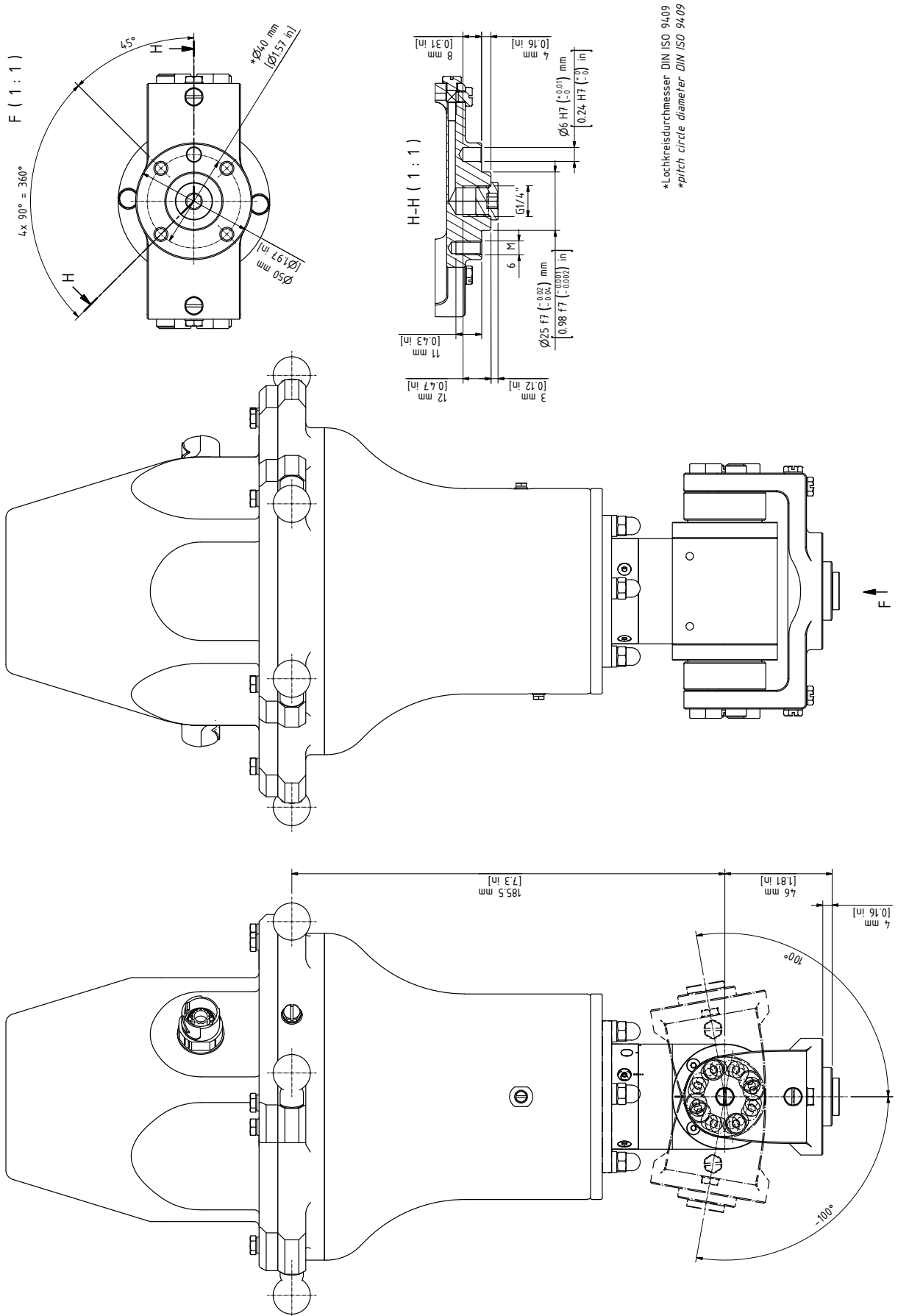

*Lochkreisdurchmesser DIN ISO 9409
 *pitch circle diameter DIN ISO 9409

Mounting the Gripper to the Tilting Module HT-B-HD

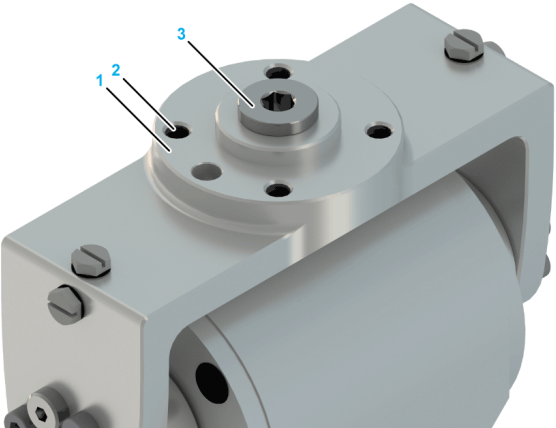
Step	Action
1	<p>Fasten the gripper to the mounting points at the flange (1):</p> <ul style="list-style-type: none"> • Pitch circle diameter DIN ISO 9409-1, 40 mm (1.57 in): 4 x M6 (2), tightening torque: 4.5 Nm (40 lbf-in), strength class of the screw: at least A2-70 • Thread for suction pads G1/4": G1/4" x 12 mm (G1/4" x 0.47 in) (3), tightening torque: depends on your gripper. Closed with a screw plug as standard. <p>For further information, refer to <i>Flange Dimensions for the Tilting Module HT-B-HD</i>, page 172.</p> <div style="text-align: center;">  </div>
2	<p>Calibrate the Tilting Module HT-B-HD if this has not been done before mounting the gripper. For further information, refer to <i>Calibrating the Tilting Module</i>, page 234.</p> <p>NOTE:</p> <ul style="list-style-type: none"> • Observe the permissible weights and distances that result in the <i>maximum tilting torque</i>, page 167. • The maximum torque must not be exceeded. For the respective values, refer to <i>Mechanical and Electrical Data of the Tilting Modules</i>, page 166.

Flange Dimensions for the Tilting Module HT-B-HD

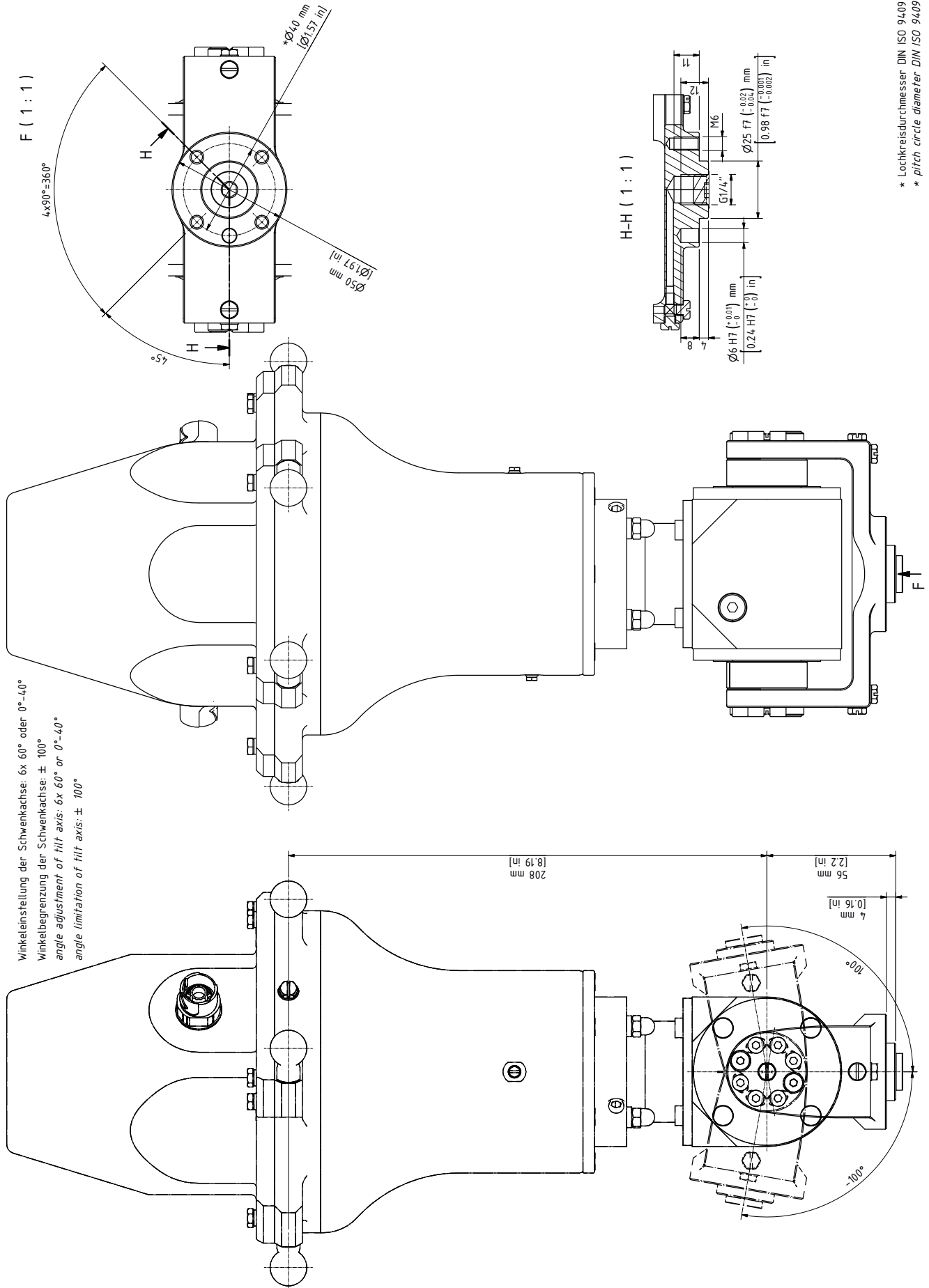

* Lochkreisdurchmesser DIN ISO 9409
 * pitch circle diameter DIN ISO 9409

Double Rotational Modules

Product Overview of the Double Rotational Modules

Overview

Some applications require the use of a further drive axis for the gripper. For such applications, you can apply the Lexium P Double Rotational Module to the Lexium P Robot.

The following figure shows the Lexium P Double Rotational Module – VRKPXXXXXX00038.



The following figure shows the Lexium P Double Rotational Module HD – VRKPXXXXXX00049.



Motion of the Tilting Axis

NOTE: The motors of the Double Rotational Modules are not equipped with a brake.

⚠ CAUTION

UNINTENDED MOTION OF THE AXES

Ensure that powering down the motor poses no subsequent risk in the zone of operation.

Failure to follow these instructions can result in injury or equipment damage.

Type Plate of the Double Rotational Modules

The type plate of the Double Rotational Module is provided in the packaging. You can attach the type plate next to the type plate of the robot, page 28.

The type plate design is the same as for the Rotational Module, page 157.

Technical Data of the Double Rotational Modules

Mechanical and Electrical Data of the Double Rotational Modules

Category	Parameter	Unit	VRKPXY YYY00038	VRKPXY YYY00049
General data	Maximum load without restrictions	kg (lb)	1.5 (3.3)	3 (6.6)
	Load with restrictions ⁽¹⁾	kg (lb)	1.5...10.0 (3.3...22)	3...10 (6.6...22)
	Allocation of auxiliary axes	–	4th and 5th	
	Maximum torque of the 4th axis ⁽²⁾	Nm (lbf-in)	9 (80)	10 (89)
	Maximum torque of the 5th axis ⁽²⁾	Nm (lbf-in)	7.5 (66)	10 (89)
	Position repeatability (ISO 9283)	–	Angle: +/-0.1°	
Electrical data	Mains voltage - 3-phase	Vac	480 ⁽³⁾	
	Motor 4th and 5th axis	–	SH30401P07A2000 ⁽⁴⁾	
	Maximum current of 4th axis motor ⁽⁵⁾	A	⁽⁶⁾	2.7
	Maximum current of 5th axis motor ⁽⁵⁾	A	⁽⁶⁾	1.6
Mechanical data	Protection class	–	IP65	
	Gear ratio <i>i</i> of the 4th axis	–	440/36	704/36
	Drive parameter <i>GearOut</i> of the 4th axis motor	–	440	704
	Drive parameter <i>GearIn</i> of the 4th axis motor	–	36	
	Gear ratio <i>i</i> of the 5th axis motor	–	10/1	32/1
	Drive parameter <i>GearOut</i> of the 5th axis motor	–	10	32
	Drive parameter <i>GearIn</i> of the 5th axis motor	–	1	
	Maximum speed of the 4th axis	1/min	800	460
	Maximum speed of the 5th axis	1/min	900	280
	Software parameter <i>TcpPlateSize</i>	mm (in)	75 (2.95) ⁽⁷⁾	
Pneumatic data	Number of pneumatic connections	–	2	0
	Operating pressure	bar (psi)	-0.95...+6 (-13.8...+87)	–
Working space	Rotation 4th axis	–	Unlimited	
	Rotation 5th axis / tilting 5th axis	–	Unlimited	
Weight	–	kg (lb)	4 (8.8)	

Category	Parameter	Unit	VRKPY YYY00038	VRKPY YYY00049
Material	External casing	–	Aluminum, stainless steel 1.4301, steel nickel-plated, zinc nickel-plated, brass nickel-plated, FPM, EPDM	Aluminum, stainless steel 1.4301, steel nickel-plated, zinc nickel-plated, brass nickel-plated, FPM, EPDM, PE
<p>(1) Loads above the maximum load are possible with restrictions. If required, contact your local Schneider Electric service representative.</p> <p>(2) When designing the gripper, be aware of any appearance of mass moments of inertia as well as friction, which could lead to exceeding the maximum torque and consequential damage.</p> <p>(3) For further information, refer to <i>Lexium 52 Hardware Guide</i> or <i>Lexium 62 Hardware Guide</i>.</p> <p>(4) Motor without brake.</p> <p>(5) Use the drive parameter <i>UserDrivePeakCurrent</i> to adjust the maximum current.</p> <p>(6) See the limitation of the specific motor.</p> <p>(7) This value is the distance between the suspension points of the lower arms and the center of the flange plate.</p>				

Interference of the Working Space with Double Rotational Modules

In the following figure are only those working space dimensions shown that are influenced by the Double Rotational Modules or the Rotational Tilting Modules, page 184. For further information about the working space, refer to *Mechanical and Electrical Data*, page 31.

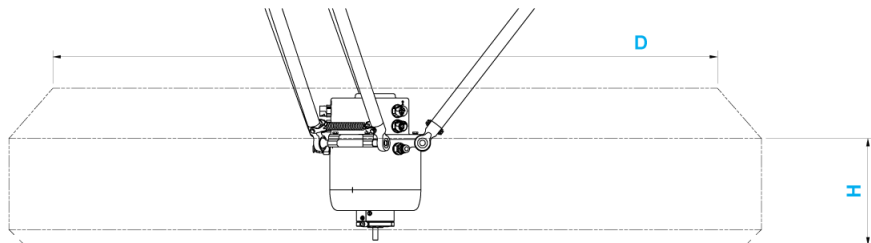

Dimension	Unit	Robot type						
		VRKP0	VRKP1	VRKP2	VRKP4	VRKP5	VRKP6	VRKP6E00
H	mm (in)	— ⁽¹⁾	— ⁽¹⁾	— ⁽¹⁾	170	230	200	250
D	mm (in)	— ⁽¹⁾	— ⁽¹⁾	— ⁽¹⁾	Ø1060	Ø1310	Ø1440	Ø1280
<p>(1) The working space is not influenced by the Double Rotational Modules, page 173 and Rotational Tilting Modules, page 184.</p>								

Maximum Tilting Torque

The loading capacity of the Double Rotational Module is limited by the maximum tilting torque at the ball pins level. The following diagram shows the possible vertical distance of the mass at its center of gravity of the payload to the FCP relative to the mass and the required maximum acceleration.

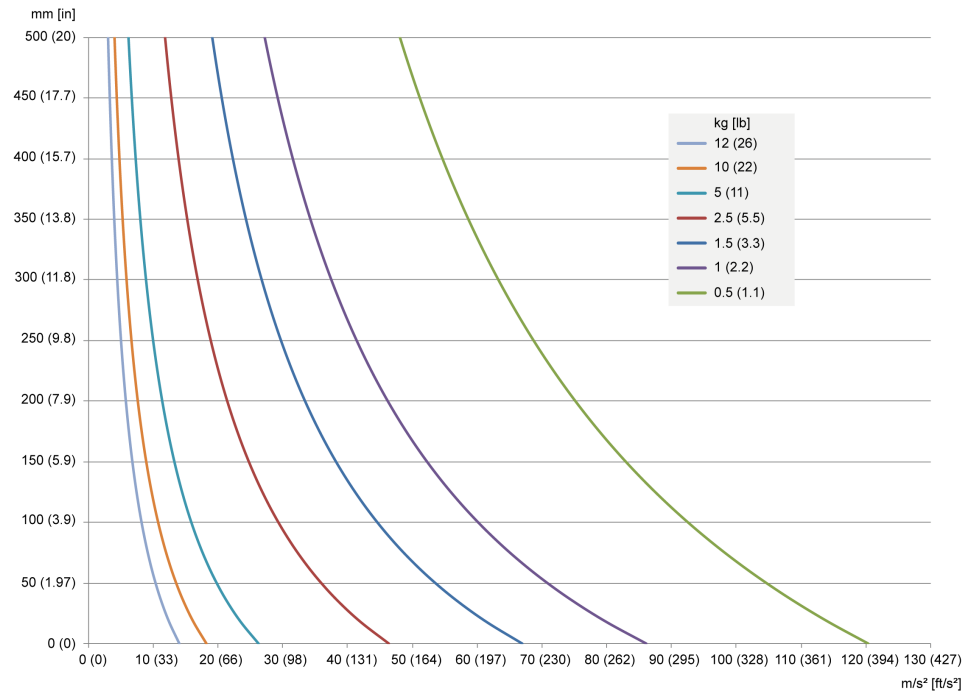

A maximum tilting torque of 20 Nm (177 lbf-in) is to be observed at the ball pins level.

Calculate the tilting torque with the following formula:

$$\text{Tilting torque [Nm (lbf-in)]} = \text{total payload [kg (lb)]} \times \text{maximum acceleration [m/s}^2 \text{ (ft/s}^2\text{)]} \times \text{vertical distance [m (in)]}$$

NOTE:

- Total payload [Nm (lbf-in)] = weight of the module + weight of the gripper + weight of the customer end product
- Vertical distance [m (in)] = distance from the ball pins level to the total mass center point = (weight of the module [kg (lb)] x vertical distance from the ball pins to the mass center point of the module (A) [m (in)] + weight of the gripper and the customer end product [kg (lb)] x (vertical distance from the FCP (flange center point) to the mass center point of the gripper and the customer end product (C) [m (in)] + vertical distance from the ball pins to the FCP (B) [m (in)])) / total payload [kg (lb)]

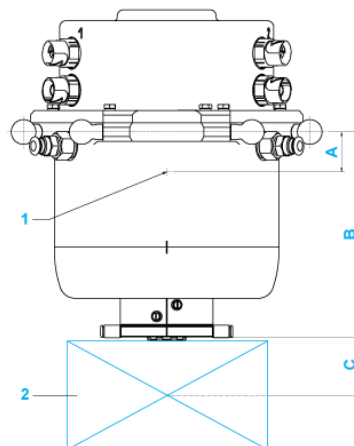

1 Mass center point of the module

2 Gripper and customer end product

Dimension	Description	Unit	Double Rotational Module	Double Rotational Module HD
A	Vertical distance from the ball pins to the mass center point of the module	mm (in)	25 (0.98)	25 (0.98)
B	Vertical distance from the ball pins to the FCP	mm (in)	132.5 (5.2)	130 (5.1)
C	Vertical distance from FCP to the mass center point of the gripper and the customer end product	mm (in)	Depends on the gripper and the customer end product	

Mounting the Double Rotational Modules

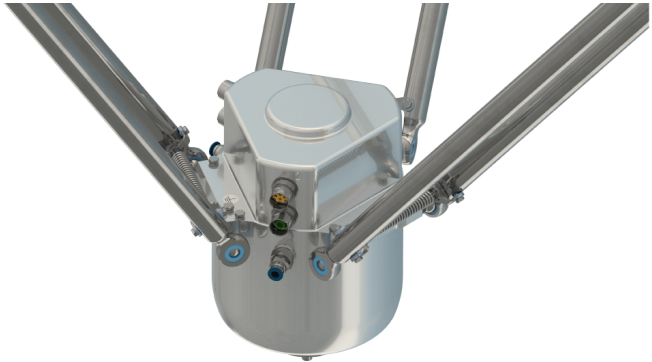
Step	Action
1	<p>Hook in the lower arms on the Double Rotational Module.</p> <p>For further information, refer to <i>Hooking in the Lower Arms</i>, page 134.</p> 

Cabling the Double Rotational Modules

Overview

For cabling the Rotational Module, use only Schneider Electric extension cables that are specifically designed for the robot application.

The following table presents the appropriate cable for each robot type.

Robot type	Cable length	Cable type	Order number
VRKP0	3 m (9.8 ft)	Encoder extension cable	VW3E2100R030
VRKP1		Power extension cable	VW3E1168R030
VRKP2			
VRKP4			
VRKP5	4.3 m (14 ft)	Encoder extension cable	VW3E2100R043
VRKP6		Power extension cable	VW3E1168R043

If other cable lengths are required, contact your local Schneider Electric service representative.

Cabling the Double Rotational Module

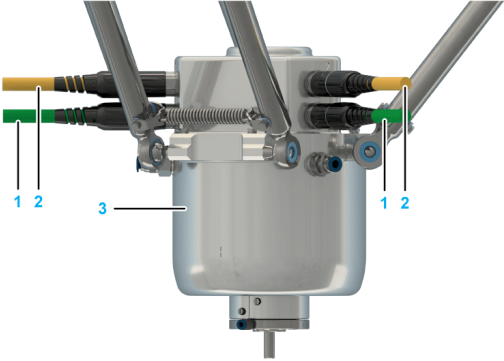
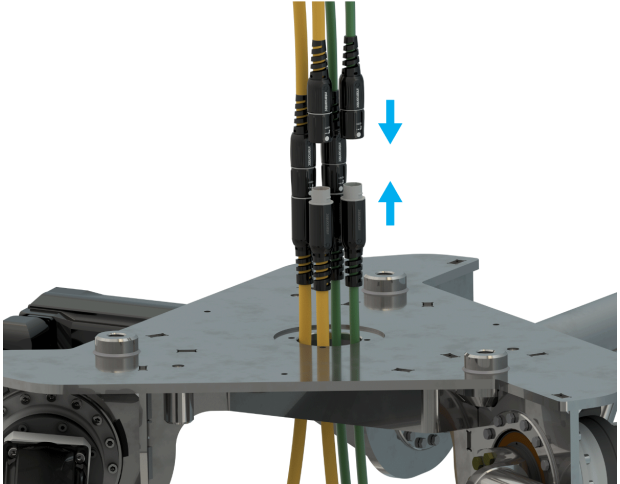
Step	Action
1	Feed two encoder cables for SH3040 motors to the middle of the robot housing.
2	Feed two power cables for SH3040 motors to the middle of the robot housing. NOTE: For equipment that you are supplying that is not described in the present document, consult the documentation for those products.
3	<p>Connect the two encoder extension cables (VW3E2100R***) (1) and the two power extension cables (VW3E1168R***) (2) to the Double Rotational Module (3) as described for the SH3040 motor in the <i>SH3 Servo motor Motor Manual</i>.</p> <div style="text-align: center;">  <p>The diagram shows a top-down view of the Double Rotational Module. Two green cables (labeled 1) and two yellow cables (labeled 2) are connected to the module. A blue cable (labeled 3) is also connected. The module is a cylindrical component with a central shaft.</p> </div> <p>NOTE: For cabling the Double Rotational Module use only Schneider Electric extension cables that are specifically designed for the robot application.</p>
4	<p>Feed the two encoder extension cables and the two power extension cables from the Double Rotational Module via the lower and upper arms of the robot into the robot housing.</p> <p>NOTE:</p> <ul style="list-style-type: none"> • Attach the cables to the lower and upper arms so that the cables have sufficient freedom of movement to reach with the TCP all positions in the working space. • Consider the bending radius for the respective cables: <ul style="list-style-type: none"> ◦ VW3E1168R*** – minimum bending radius: 69 mm (2.7 in) ◦ VW3E2100R*** – minimum bending radius: 63 mm (2.5 in)
5	<p>Connect the cables in the robot housing with the cables from the Double Rotational Module.</p> <div style="text-align: center;">  <p>The diagram shows a close-up of the robot housing with several cables (yellow, green, and black) being inserted into a central opening. Blue arrows indicate the direction of cable insertion.</p> </div> <p>NOTE: For the washdown robot references, contact your local Schneider Electric representative.</p>
6	Verify the correct routing and fastening of the cables to help prevent any collision of cables and moving parts.

NOTICE

INCORRECT PAIRING OF POWER AND ENCODER CABLES

Label the power and associated encoder cables according to their pairing.

Failure to follow these instructions can result in equipment damage.

Grounding Robots with the Double Rotational Module

Ground those parts of the robot which are located where either contact with current carrying parts (cables) or an insulation error is probable.

Alternatively, protect the cables with insulation which withstands the mechanical, chemical, electrical, and thermal stresses that it can be subjected to during normal operating conditions.

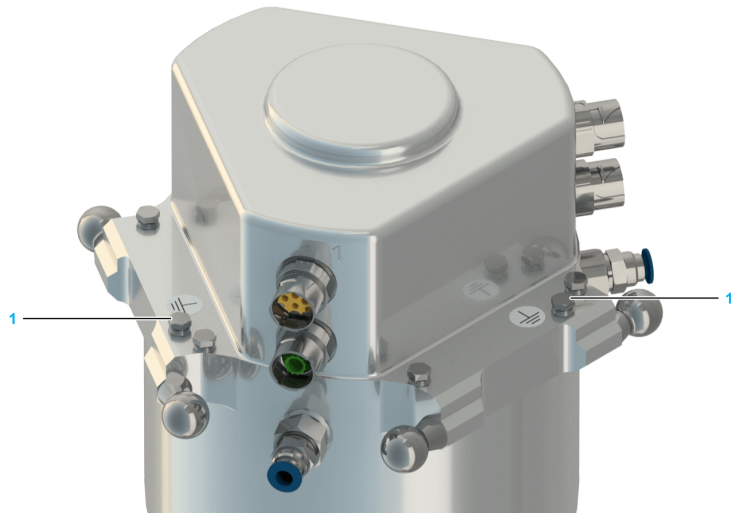

Ground the Double Rotational Module via one of the screws (1) for protective ground (earth) if grounding via the protective ground conductor of the motor cable is insufficient. To ensure an ideal electrical connection, use a serrated lock washer between the housing and cable lug. The tightening torque of the screws is 2 Nm (17.7 lbf-in).

⚠️⚠️ DANGER

ELECTRIC SHOCK DUE TO IMPROPER GROUNDING

- Ground robot components in accordance with local, regional and/or national standards and regulations at a single, central point.
- Verify that the motors are connected to the central ground.

Failure to follow these instructions will result in death or serious injury.

Mounting the Payload to the Double Rotational Modules

Overview

Here you will find the following information:

- Mounting the gripper to the Double Rotational Module, page 180
- Flange dimensions for the Double Rotational Module, page 181
- Supply of the gripper on the Double Rotational Module, page 182
- Mounting the gripper to the Double Rotational Module HD, page 182
- Flange dimensions for the Double Rotational Module HD, page 183

Mounting the Gripper to the Double Rotational Module

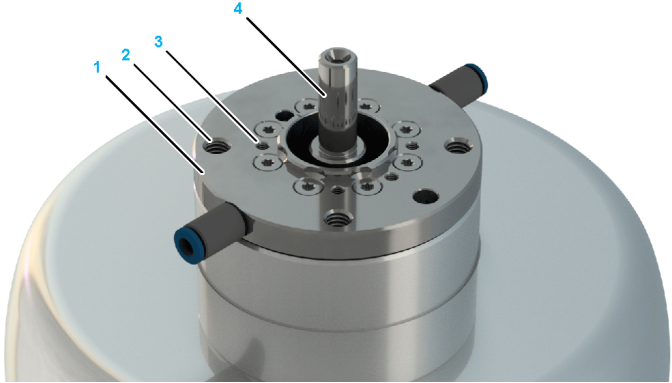
Step	Action
1	<p>Fasten the gripper to the mounting points at the rotating flange (1):</p> <ul style="list-style-type: none"> • Pitch circle diameter DIN ISO 9409-1, 50 mm (1.97 in): 4 x M6 (2), tightening torque: 4.5 Nm (40 lbf-in), strength class of the screw: at least A2-70 • Pitch circle diameter 31 mm (1.22 in): 5 x M4 (3), tightening torque: 1.4 Nm (12.4 lbf-in), strength class of the screw: at least A2-70 • Shaft diameter fifth axis 8 mm (0.315 in): 8 x 20 mm (0.315 x 0.79 in) (4) <p>For further information, refer to <i>Flange Dimensions for the Double Rotational Module</i>, page 181.</p> 
2	<p>Calibrate the Double Rotational Module if this has not been done before mounting the gripper. For further information, refer to <i>Calibrating the Double Rotational Module and the Rotational Tilting Module</i>, page 232.</p> <p>NOTE:</p> <ul style="list-style-type: none"> • Observe the permissible weights and distances that result in the <i>maximum tilting torque</i>, page 159. • The maximum torque must not be exceeded. For the respective values, refer to <i>Mechanical and Electrical Data of the Double Rotational Modules</i>, page 174.

Flange Dimensions for the Double Rotational Module

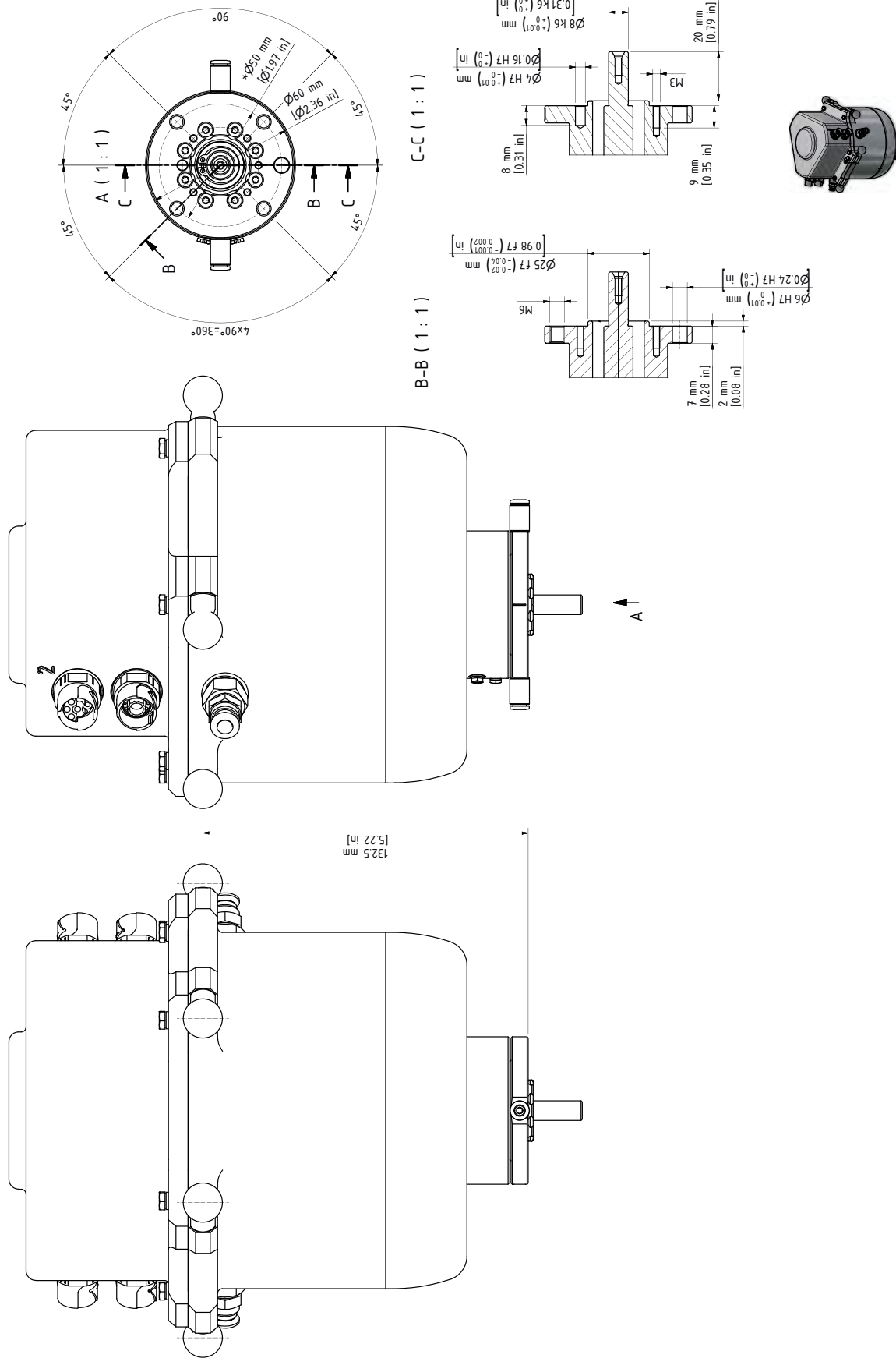

* Lochkreisdurchmesser DIN ISO 9409-1-50-4-M6
 * pitch circle diameter DIN ISO 9409-1-50-4-M6

Supply of the Gripper on the Double Rotational Module

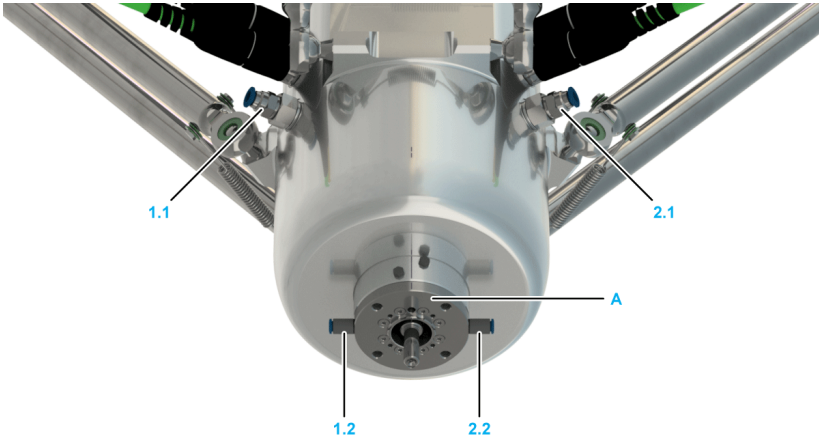
Step	Action
1	<p>Connect the media line to one of the pneumatic plug-in connections (1.1 or 2.1) of the Double Rotational Module. The plug-in connection has a diameter of 6 mm (0.236 in).</p>  <p>For further information, refer to <i>Supply of the Gripper</i>, page 143.</p>
2	<p>Connect the media line of the gripper to the associated pneumatic plug-in connection (1.2 or 2.2) on the pneumatics rotary union (A). The plug-in connection has a diameter of 4 mm (0.157 in).</p> <p>NOTE:</p> <ul style="list-style-type: none"> • Connection 1.1 is linked to connection 1.2 • Connection 2.1 is linked to connection 2.2

Mounting the Gripper to the Double Rotational Module HD

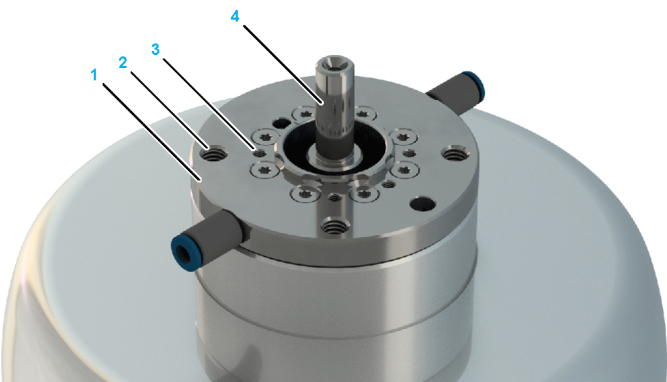
Step	Action
1	<p>Fasten the gripper to the mounting points at the rotating flange (1):</p> <ul style="list-style-type: none"> • Pitch circle diameter DIN ISO 9409-1, 56 mm (2.2 in): 4 x M5 (2), tightening torque: 3.5 Nm (31 lbf-in), strength class of the screw: at least A2-70 • Shaft diameter fifth axis 12 mm (0.47 in): 12 x 17 mm (0.47 x 0.67 in) (3) <p>For further information, refer to <i>Flange Dimensions for the Double Rotational Module HD</i>, page 183.</p> 
2	<p>Calibrate the Double Rotational Module HD if this has not been done before mounting the gripper. For further information, refer to <i>Calibrating the Double Rotational Module and the Rotational Tilting Module</i>, page 232.</p> <p>NOTE:</p> <ul style="list-style-type: none"> • Observe the permissible weights and distances that result in the <i>maximum tilting torque</i>, page 159. • The maximum torque must not be exceeded. For the respective values, refer to <i>Mechanical and Electrical Data of the Double Rotational Modules</i>, page 174.

Flange Dimensions for the Double Rotational Module HD

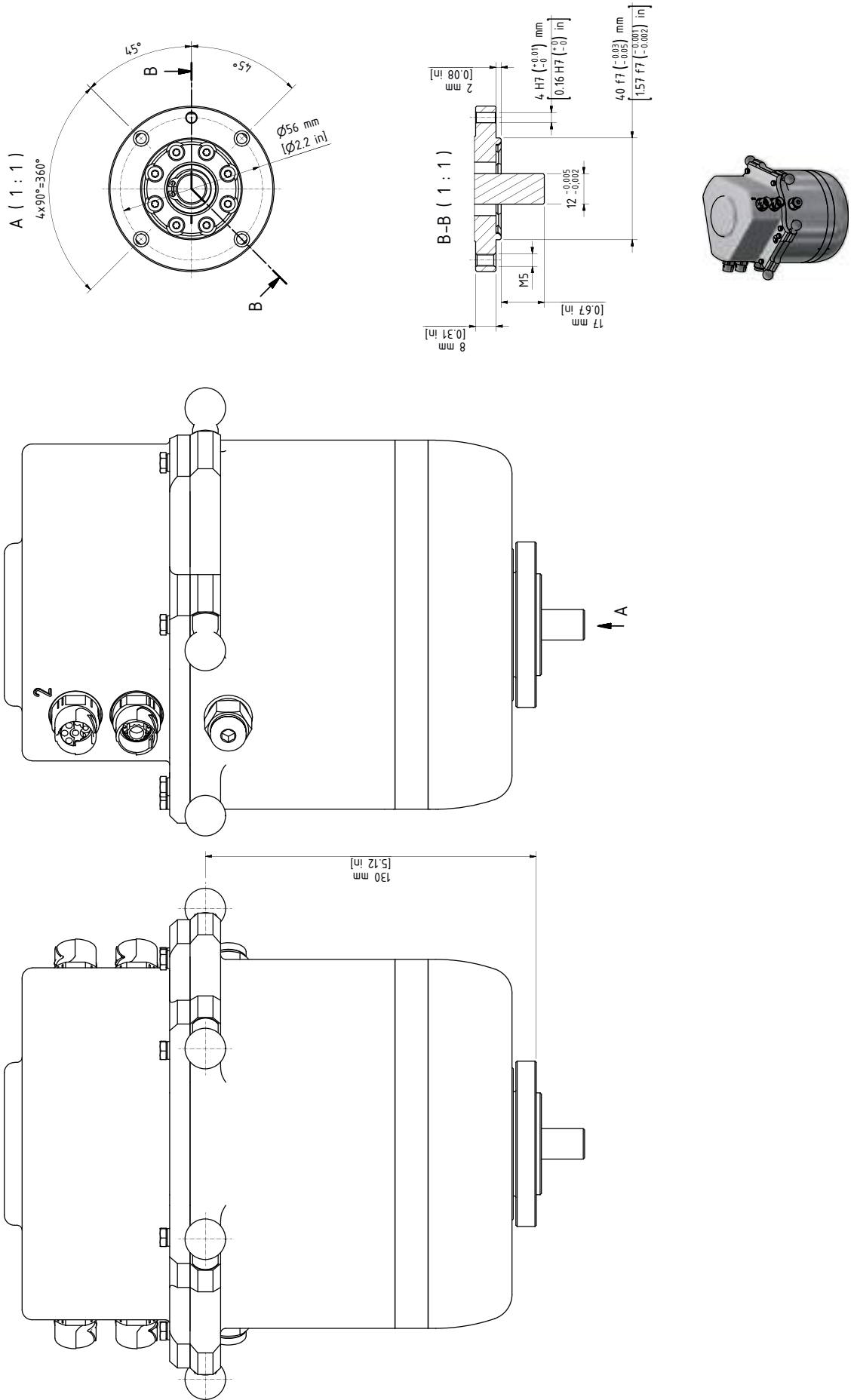

Rotational Tilting Modules

Product Overview of the Rotational Tilting Modules

Overview

Some applications require the use of an additional tilting axis. For such applications, you can apply the Lexium P Rotational Tilting Module to the Lexium P Robot.

The following figure shows the Lexium P Rotational Tilting Module – VRKPXXXXXX00039.



The following figure shows the Lexium P Rotational Tilting Module HD – VRKPXXXXXX00041 and the Rotational Tilting Module HD-B – VRKPXXXXXX00050.



Motion of the Tilting Axis

NOTE: The motor of the tilting axis of the Rotational Tilting Module and Rotational Tilting Module HD is not equipped with a brake.

⚠ CAUTION

UNANTICIPATED SWIVEL MOTION OF THE TILTING AXIS

Ensure that powering down the motor poses no subsequent risk in the zone of operation.

Failure to follow these instructions can result in injury or equipment damage.

Type Plate of the Rotational Tilting Modules

The type plate of the Rotational Tilting Modules is provided in the packaging. You can attach the type plate next to the type plate of the robot, page 28.

The type plate design is the same as for the Rotational Module, page 157.

Technical Data of the Rotational Tilting Modules

Mechanical and Electrical Data of the Rotational Tilting Modules

Category	Parameter	Unit	VRKPXXXXY Y00039	VRKPXXXXY Y00041	VRKPXXXXY Y00050
General data	Maximum load without restrictions	kg (lb)	0.25 (0.55)	0.5 (1.1)	0.5 (1.1)
	Load with restrictions ⁽¹⁾	kg (lb)	0.25...2.5 (0.55...5.5)	0.5...5.0 (1.1...11)	0.5...5.0 (1.1...11)
	Allocation of auxiliary axes	–	4th and 5th		
	Maximum torque of the 4th axis ⁽²⁾	Nm (lbf-in)	9 (80)	10 (89)	10 (89)
	Maximum torque of the 5th axis ⁽²⁾	Nm (lbf-in)	7.5 (66)	20 (177)	20 (177)
	Maximum holding torque of 4th and 5th motor	Nm (lbf-in)	–	–	5 (44)
	Position repeatability (ISO 9283)	–	Angle: +/-0.1°		
Electrical data	Mains voltage - 3-phase	Vac	480 ⁽³⁾		
	Motor 4th and 5th axis	–	SH30401P07A2000 ⁽⁴⁾		SH30401P07-F2000
	Maximum current of 4th axis motor ⁽⁵⁾	A	⁽⁶⁾	2.7	2.7
	Maximum current of 5th axis motor ⁽⁵⁾	A	⁽⁶⁾	1.6	1.6
Mechanical data	Protection class	–	IP65		
	Gear ratio <i>i</i> of the 4th axis	–	440/36	704/36	704/36
	Drive parameter <i>GearOut</i> of the 4th axis motor	–	440	704	704
	Drive parameter <i>GearIn</i> of the 4th axis motor	–	36	36	36
	Gear ratio <i>i</i> of the 5th axis motor	–	10/1	64/1	64/1
	Drive parameter <i>GearOut</i> of the 5th axis motor	–	10	64	64
	Drive parameter <i>GearIn</i> of the 5th axis motor	–	1	1	1
	Maximum speed of the 4th axis	1/min	800	460	460
	Maximum speed of the 5th axis	1/min	900	140	140
	Software parameter <i>TcpPlateSize</i>	mm (in)	75 (2.95) ⁽⁷⁾		
Pneumatic data	Number of pneumatic connections	–	2	0	0
	Operating pressure	bar (psi)	-0.95...+6 (-13.8...+87)	–	–

Category	Parameter	Unit	VRKPYYYY Y00039	VRKPYYYY Y00041	VRKPYYYY Y00050
Working space	Rotation 4th axis	–	Unlimited		
	Rotation 5th axis / tilting 5th axis	–	+/-100°		
Weight	–	kg (lb)	4.8 (10.6)	5.4 (11.9)	5.7 (12.6)
Material	External casing	–	Aluminum, stainless steel 1.4301, steel nickel-plated, zinc nickel-plated, brass nickel-plated, FPM, EPDM, PE		

(1) Loads above the maximum load are possible with restrictions. If required, contact your local Schneider Electric service representative.

(2) When designing the gripper, be aware of any appearance of mass moments of inertia as well as friction, which could lead to exceeding the maximum torque and consequential damage.

(3) For further information, refer to *Lexium 52 Hardware Guide* or *Lexium 62 Hardware Guide*.

(4) Motor without brake.

(5) Use the drive parameter *UserDrivePeakCurrent* to adjust the maximum current.

(6) See the limitation of the specific motor.

(7) This value is the distance between the suspension points of the lower arms and the center of the flange plate.

Interference of the Working Space with Rotational Tilting Modules

By using the Rotational Tilting Modules, the working space of the robot is influenced. This modified working space is the same as for the Double Rotational Module. Therefore, refer to *Interference of the Working Space with the Double Rotational Module*, page 175 for further information.

Maximum Tilting Torque

The loading capacity of the Rotational Tilting Modules is limited by the maximum tilting torque at the ball pins level. The following diagram shows the possible vertical distance of the mass at its center of gravity of the payload to the FCP relative to the mass and the required maximum acceleration.

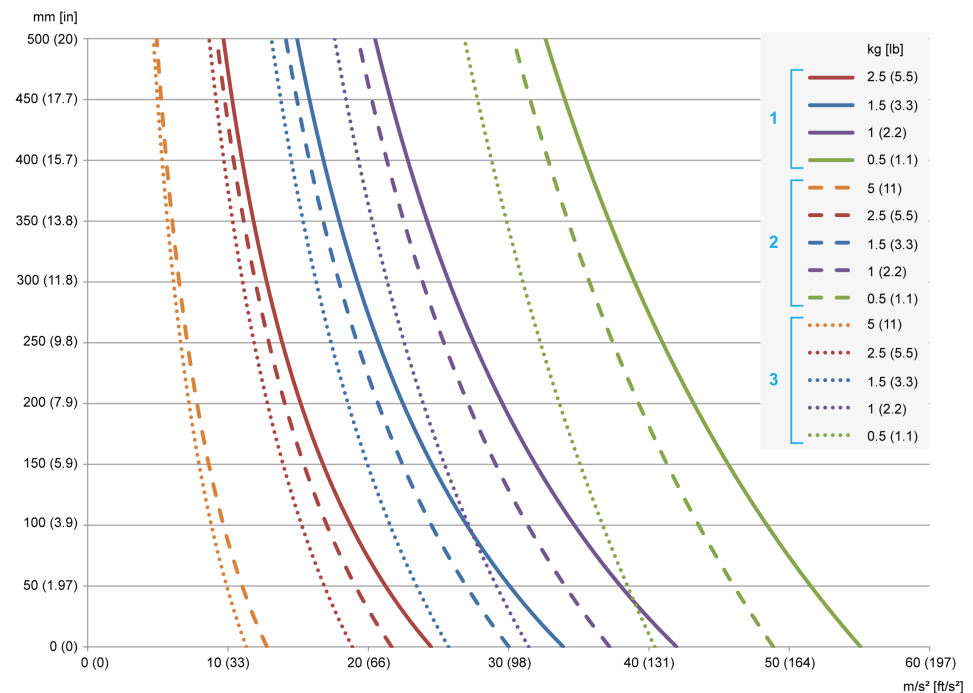

1 Rotational Tilting Module

2 Rotational Tilting Module HD

3 Rotational Tilting Module HD-B

A maximum tilting torque of 20 Nm (177 lbf-in) is to be observed at the ball pins level.

Calculate the tilting torque with the following formula:

$$\text{Tilting torque [Nm (lbf-in)]} = \text{total payload [kg (lb)]} \times \text{maximum acceleration [m/s}^2 \text{ (ft/s}^2\text{)]} \times \text{vertical distance [m (in)]}$$

NOTE:

- Total payload [Nm (lbf-in)] = weight of the module + weight of the gripper + weight of the customer end product
- Vertical distance [m (in)] = distance from the ball pins level to the total mass center point = (weight of the module [kg (lb)] x vertical distance from the ball pins to the mass center point of the module (A) [m (in)] + weight of the gripper and the customer end product [kg (lb)] x (vertical distance from the FCP (flange center point) to the mass center point of the gripper and the customer end product (C) [m (in)] + vertical distance from the ball pins to the FCP (B) [m (in)])) / total payload [kg (lb)]

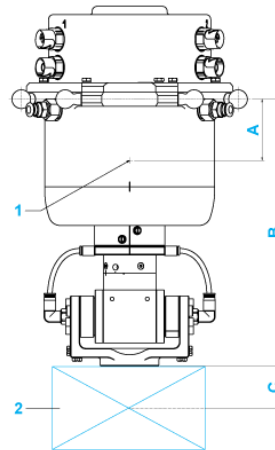

1 Mass center point of the module

2 Gripper and customer end product

Dimension	Description	Unit	Rotational Tilting Module	Rotational Tilting Module HD	Rotational Tilting Module HD-B
A	Vertical distance from the ball pins to the mass center point of the module	mm (in)	52 (2.05)	52 (2.05)	62 (2.44)
B	Vertical distance from the ball pins to the FCP	mm (in)	227 (9)	257 (10.1)	283 (11.1)
C	Vertical distance from FCP to the mass center point of the gripper and the customer end product	mm (in)	Depends on the gripper and the customer end product		

Mounting the Rotational Tilting Modules

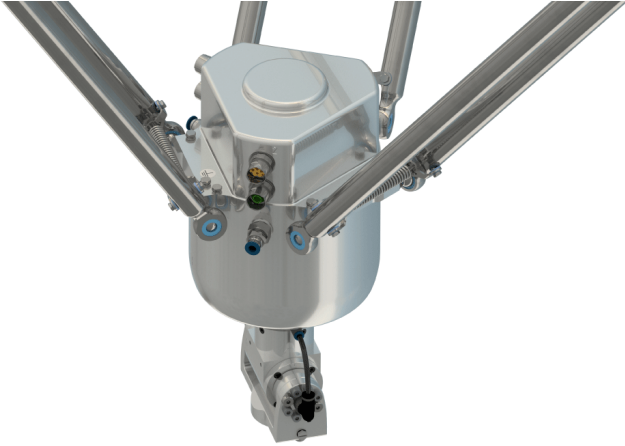
Step	Action
1	<p>Hook in the lower arms on the Rotational Tilting Module.</p> <p>For further information, refer to <i>Hooking in the Lower Arms</i>, page 134.</p> 

Cabling the Rotational Tilting Modules

Overview

The procedures for cabling and grounding the Rotational Tilting Modules are similar to the procedures for the Double Rotational Modules. Therefore, refer to *Cabling the Double Rotational Module*, page 177 for further information.

Mounting the Payload to the Rotational Tilting Modules

Overview

Here you will find the following information:

- Mounting the gripper to the Rotational Tilting Module, page 189
- Flange dimensions for the Rotational Tilting Module , page 190
- Mounting the gripper to the Rotational Tilting Module HD / HD-B, page 191
- Flange dimensions for the Rotational Tilting Module HD, page 192
- Flange dimensions for the Rotational Tilting Module HD-B, page 192
- Supply of the gripper on the Rotational Tilting Module, page 194

Mounting the Gripper to the Rotational Tilting Module

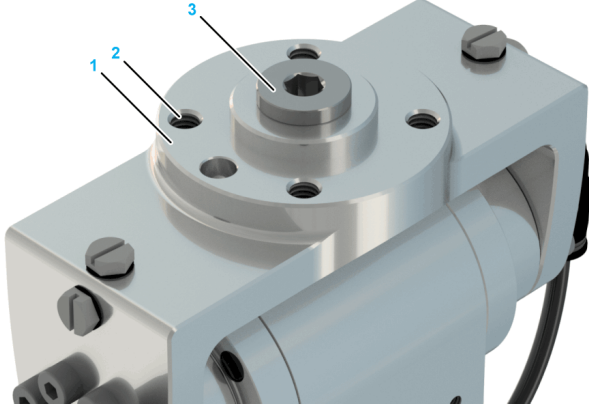
Step	Action
1	<p>Fasten the gripper to the mounting points at the flange (1):</p> <ul style="list-style-type: none"> • Pitch circle diameter DIN ISO 9409-1, 40 mm (1.57 in): 4 x M6 (2), tightening torque: 4.5 Nm (40 lbf-in), strength class of the screw: at least A2-70 • Thread for suction pads G1/4": G1/4" x 12 mm (G1/4" x 0.47 in) (3), tightening torque: depends on your gripper. <p>For further information, refer to <i>Flange Dimensions for the Rotational Tilting Module</i>, page 190.</p> 
2	<p>Calibrate the Rotational Tilting Module if this has not been done before mounting the gripper. For further information, refer to <i>Calibrating the Double Rotational Module and the Rotational Tilting Module</i>, page 232</p> <p>NOTE:</p> <ul style="list-style-type: none"> • Observe the permissible weights and distances that result in the <i>maximum tilting torque</i>, page 186. • The maximum torque must not be exceeded. For the respective values, refer to <i>Mechanical and Electrical Data of the Rotational Tilting Modules</i>, page 185.

Flange Dimensions for the Rotational Tilting Module

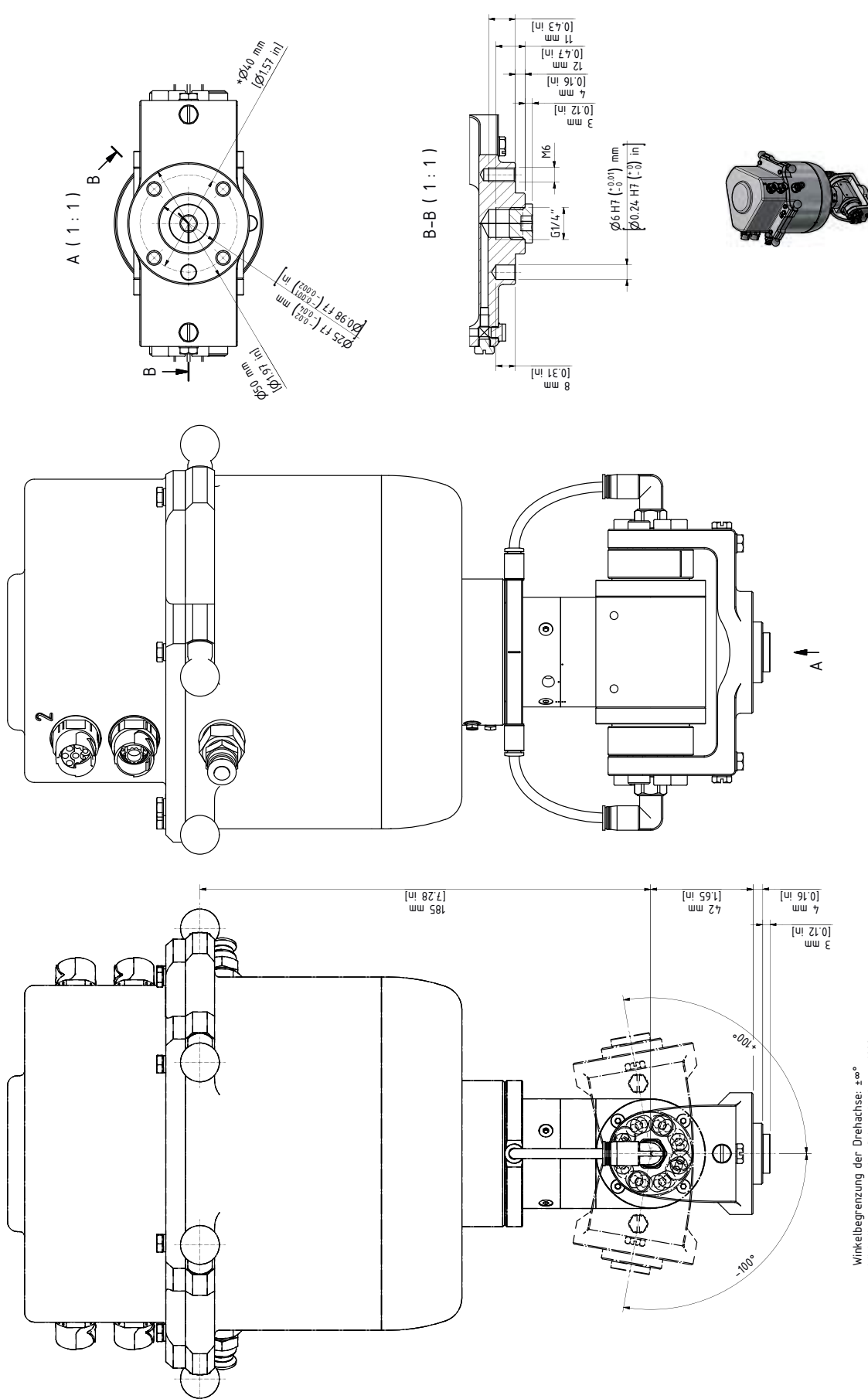

* Lochkreisdurchmesser DIN ISO 9409-1-40-4-M6
 * pitch circle diameter DIN ISO 9409-1-40-4-M6

Winkelbegrenzung der Drehachse: $\pm 100^\circ$
 Winkelbegrenzung der Schwenkachse: $\pm 100^\circ$
 angle limitation of rotational axis: $\pm 100^\circ$
 angle limitation of tilting axis: $\pm 100^\circ$

Mounting the Gripper to the Rotational Tilting Module HD / HD-B

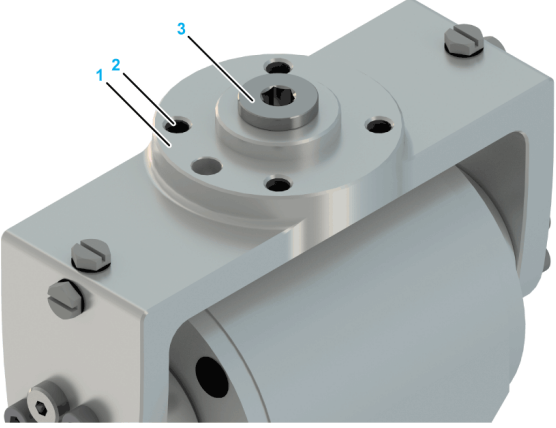
Step	Action
1	<p>Fasten the gripper to the mounting points at the flange (1):</p> <ul style="list-style-type: none"> • Pitch circle diameter DIN ISO 9409-1, 40 mm (1.57 in): 4 x M6 (2), tightening torque: 4.5 Nm (40 lbf-in), strength class of the screw: at least A2-70 • Thread for suction pads G1/4": G1/4" x 12 mm (G1/4" x 0.47 in) (3), tightening torque: depends on your gripper. Closed with a screw plug as standard. <p>For further information, refer to <i>Flange Dimensions for the Rotational Tilting Module HD</i>, page 191.</p> 
2	<p>Calibrate the Rotational Tilting Module HD if this has not been done before mounting the gripper. For further information, refer to <i>Calibrating the Double Rotational Module and the Rotational Tilting Module</i>, page 232.</p> <p>NOTE:</p> <ul style="list-style-type: none"> • Observe the permissible weights and distances that result in the <i>maximum tilting torque</i>, page 186. • The maximum torque must not be exceeded. For the respective values, refer to <i>Mechanical and Electrical Data of the Rotational Tilting Modules</i>, page 185.

Flange Dimensions for the Rotational Tilting Module HD

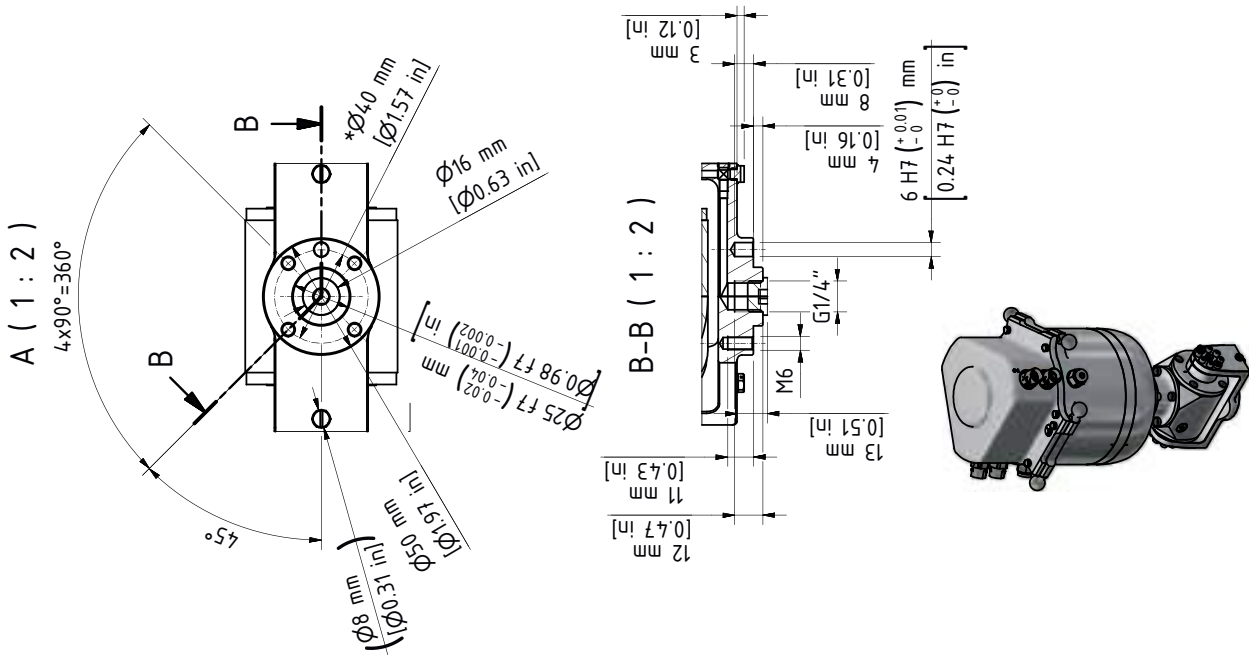

* Lochkreisdurchmesser DIN ISO-9409
 * pitch circle diameter DIN ISO-9409

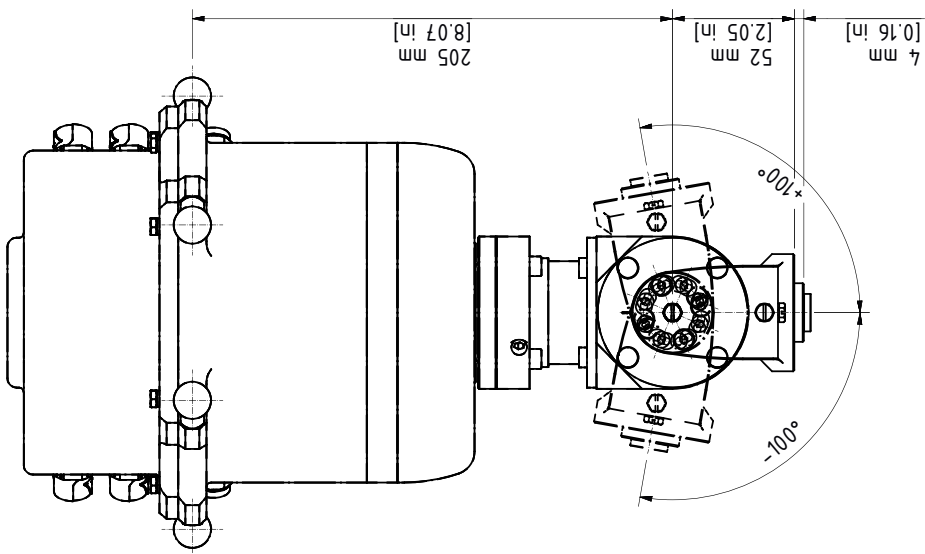
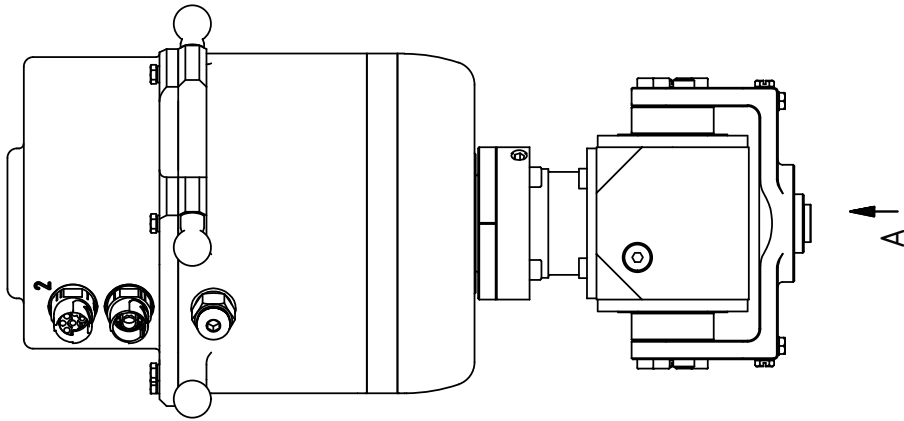

Supply of the Gripper on the Rotational Tilting Module

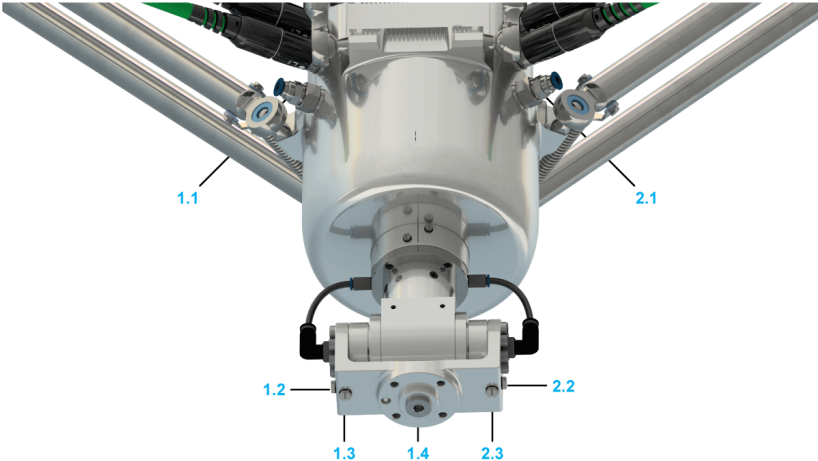
Step	Action
1	<p>Connect the media line to one of the pneumatic plug-in connections (1.1 or 2.1) of the Double Rotational Module. The plug-in connection has a diameter of 6 mm (0.236 in).</p> <p>For further information, refer to <i>Supply of the Gripper</i>, page 143.</p>
2	<p>When using a standard suction cup:</p> <p>Remove the plug screw (1.4) and mount the suction cup directly into the thread.</p> <p>Thread for suction cup: G1/4" x 12 mm (G1/4" x 0.47 in)</p> <p>NOTE: Connection 1.1 is linked to connection 1.4</p> 
3	<p>When using any of the other connections:</p> <p>Remove one of the plug screws of the associated connection (1.2, 1.3, 2.2, or 2.3) and mount your pneumatic connector.</p> <p>Thread size for the attachment: M5 x 4 mm (M5 x 0.157 in)</p> <p>NOTE:</p> <ul style="list-style-type: none"> • Connection 1.1 is linked to connection 1.2 and 1.3 • Connection 2.1 is linked to connection 2.2 and 2.3

Maintenance and Repair

What's in This Chapter

Maintenance, Repair, and Cleaning 195
 Replacing Parts..... 203
 Calibration 228

Maintenance, Repair, and Cleaning

General Information About Maintenance, Repair, and Cleaning

Overview

The use and application of the information contained herein require expertise in the design and programming of automated control systems. Only you, the user, machine builder or integrator, can be aware of all the conditions and factors present during installation and setup, operation, repair, and maintenance of the machine or process.

You must also consider any applicable standards and/or regulations with respect to grounding of all equipment. Verify compliance with any safety information, different electrical requirements, and normative standards that apply to your machine or process in the use of this equipment.

⚠️⚠️ DANGER

ELECTRIC SHOCK, EXPLOSION, OR ARC FLASH

- Disconnect all power from all equipment including connected devices prior to removing any covers or doors, or installing or removing any accessories, hardware, cables, or wires except under the specific conditions specified in the appropriate hardware guide for this equipment.
- Always use a properly rated voltage sensing device to confirm the power is off where and when indicated.
- Operate electrical components only with a connected protective ground (earth) cable.
- Verify the secure connection of the protective ground (earth) cable to all electrical devices to ensure that connection complies with the connection diagram.
- Do not touch the electrical connection points of the components when the module is energized.
- Provide protection against indirect contact.
- Insulate any unused conductors on both ends of the motor cable.

Failure to follow these instructions will result in death or serious injury.

Poor maintenance can lead to premature wear, or even present potential safety hazards for production or maintenance operators.

⚠️ WARNING

UNINTENDED EQUIPMENT OPERATION

Develop and follow a maintenance plan and associated protocols adapted to the requirements of your application and equipment.

Failure to follow these instructions can result in death, serious injury, or equipment damage.

Servicing

In case of issues which cannot be resolved, contact your local Schneider Electric service representative with the following information:

- Type plate information (type, identification number, serial number, DOM)
- Detailed description of the issue
- Previous and associated circumstances

Maintenance Plan

Overview

The maintenance intervals may have to be adapted to the greatly varying operational hours depending on the application.

For procedures to replace the different parts, refer to *Replacing Parts*, page 203.

Maintenance Schedule

Intervals	Action
Every 150 hours of operation or weekly	<ul style="list-style-type: none"> • Verify the robot by visual inspection for any damage or missing parts, especially for moving parts and parts at risk for collisions such as grippers, upper arms, lower arms, springs, telescopic axis, or parallel plates. • Replace the arms if these are bent or dented. • Clean the robot mechanics.
Every 300 hours of operation or every two weeks	<ul style="list-style-type: none"> • Verify the slide films, ball sockets, universal joints, and rolls for wear and replace them if necessary. • Only for an optionally mounted VRKPXXXXXX00038, VRKPXXXXXX00039, VRKPXXXXXX00041, VRKPXXXXXX00045, VRKPXXXXXX00046, VRKPXXXXXX00049, VRKPXXXXXX00050, VRKPXXXXXX00052, or VRKPXXXXXX00053: Verify the cables for wear and replace them if these are damaged or worn out
Every 1,000 hours of operation or every three months	<ul style="list-style-type: none"> • Verify all moving parts for bolted connections. • Verify the output shaft sealing of gearboxes for deposits of dirt and clean. • Verify the sealing gaskets at maintenance covers, media covers and motor covers by visual inspection for any damage and replace them if necessary.
Every 2,000 hours of operation	<ul style="list-style-type: none"> • Replace the springs and spring rolls of the lower arms. • Replace the ball sockets. • Replace the slide films of the telescopic axis. • Verify the universal joints on the telescopic axis and replace them if these are appreciably worn.
Every 5,000 hours of operation	<ul style="list-style-type: none"> • Verify the ball pins and replace them if necessary.
Annually	<ul style="list-style-type: none"> • Verify the brake function during operation.
Every 20,000 hours of operation	<ul style="list-style-type: none"> • Replace the main gearboxes and motors. • Replace the four-axis parallel plate (with rotational axis bearing). • Only for VRKP2***WD / VRKP4***WD / VRKP4***NO / VRKP4***CW / VRKP4***WF / VRKP5***WF / VRKP6***WF robot: Verify the fans for operation and replace them if necessary. • When using an optionally mounted VRKPXXXXXX00038, VRKPXXXXXX00039, VRKPXXXXXX00041, VRKPXXXXXX00045, VRKPXXXXXX00046, VRKPXXXXXX00049, VRKPXXXXXX00050, VRKPXXXXXX00052, or VRKPXXXXXX00053: Replace the module.

Intervals	Action
Every 40,000 hours of operation	<ul style="list-style-type: none"> • Replace the gearboxes and motors of the rotational axis. • Replace the upper arms.
Every 1,000 emergency stop situations	<ul style="list-style-type: none"> • Replace the upper arms.
Each removal of the covers	<ul style="list-style-type: none"> • Replace the sealing gasket of any cover you remove.

NOTE:

- The gearbox has been lubricated for life.
- Do **not** lubricate the ball sockets.

Maintaining the Telescopic Axis

Overview

The wear of the telescopic axis becomes noticeable over time by an increasing backlash in the mechanics which comprises the backlash of the slide films and the backlash of the universal joints.

Maintaining the Telescopic Axis

Step	Action
1	Verify whether the slide films have backlash, page 198.
2	Verify whether the universal joints have backlash, page 199.

Maintaining the Springs

Overview

Periodically verify and replace the springs in accordance with the maintenance schedule.

Replace the springs and spring rolls at the latest when the ball sockets are worn.

For further information, refer to *Maintaining the Ball Sockets*, page 198.

▲ WARNING
<p>INCREASED WEAR OR COLLISION OF COMPONENTS</p> <p>Only use springs approved by Schneider Electric.</p> <p>Failure to follow these instructions can result in death, serious injury, or equipment damage.</p>

NOTE: In order to help prevent the arms from becoming dislocated, use suitable springs which can be purchased from Schneider Electric as replacement equipment.

▲ WARNING
<p>COLLISION OF ROBOT COMPONENTS</p> <p>Perform continuous maintenance by inspecting springs for cracks or signs of elongation due to exceeded elastic limits (overstretch).</p> <p>Failure to follow these instructions can result in death, serious injury, or equipment damage.</p>

Maintaining the Slide Films

Overview

The slide films on the telescopic axis wear with time so that backlash starts to occur on the telescopic axis.

How fast slide films wear depends on the following:

- Load applied
- Paths traveled
- Movement speeds and transverse accelerations
- Quantity and type of contamination
- Material of the slide films

Verifying the Wear of the Slide Films

Step	Action
1	Measure the circumferential backlash of the slide films.
2	If the backlash is greater than $\pm 0.5^\circ$ or no longer sufficient for the application, replace the slide films, page 208.
3	Verify the total operating hours of the robot according to the maintenance plan, page 196 and replace the slide films if necessary, page 208.

Maintaining the Rolls on the Spring Pack of the Lower Arm

Overview

Periodically verify and replace rolls in accordance with the maintenance schedule, page 196.

NOTE: Roll wear increases the wear of the springs.

Maintaining the Rolls on the Spring Pack of the Lower Arm

⚠ WARNING

COLLISION OF COMPONENTS

- Replace rolls frequently.
- Always replace rolls and springs together.
- After replacing the rolls, verify them for free rotatability.

Failure to follow these instructions can result in death, serious injury, or equipment damage.

Step	Action
1	Verify whether the rolls can move by more than 0.5 mm (0.0197 in) in radial direction.
2	If the rolls can move by more, replace the rolls, page 216 and the springs, page 215.

Maintaining the Ball Sockets

Overview

Periodically verify and replace the ball sockets in accordance with the maintenance schedule, page 196.

NOTE: A collection of dirt and debris in the sockets may cause squeaking noises.

Clean the ball sockets at regular intervals.

Verifying the Wear of the Ball Sockets

NOTE: Do not remove the robot arm for this verification.

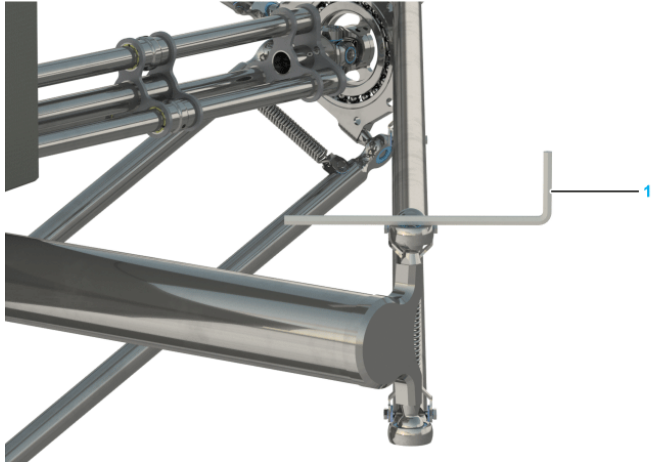
Step	Action
1	<p>Place a level object, for example, a hex key (1), on the outside of the respective lower arm head of the ready-to-operate robot.</p> <p>NOTE: The ball sockets can be verified in the working space when the robot is installed and in random position.</p> 
2	<p>If the level object is not laying plane on the lower arm head and is in contact with the ball pin, replace the ball socket, page 215.</p>

Maintaining the Universal Joints

Overview

The universal joints on the telescopic axis wear with time so that backlash starts to occur on the telescopic axis.

Maintaining the Universal Joints

Step	Action
1	<p>Verify whether the wear of the plain bearings of the universal joints exceeds the limit value of the application.</p>
2	<p>Replace the plain bearings, page 206 if necessary.</p> <p>NOTE: When using plastic universal joints, replace the universal joints, page 205.</p>

Maintaining the Ball Pins

Overview

Periodically verify and replace the ball pins in accordance with the maintenance schedule, page 196.

NOTE: A collection of dirt and debris at the pins may cause squeaking noises. Clean the ball pins at regular intervals.

Maintaining the Ball Pins

Step	Action
1	Verify the ball pins visually for any damages (for example scratches or dents). NOTE: An immoderate abrasion of one ball socket may indicate a damage of the ball pins.
2	If there is a damage, replace the ball pins, page 226.

Maintaining the Fans

Step	Action
1	Verify that the fans are working correctly. NOTE: The fans take air from the central area of the housing and blow it out through the slit in the motor covers.
2	If the fans do not work correctly, replace the fans, page 227.

Maintaining the Motor (Optional Equipment)

For information about maintaining the motor, record the motor reference on the type plate and refer to the corresponding motor manual.

Maintaining the Gearbox

Step	Action
1	Verify the gearbox by visual inspection for leakages and deposits of dirt on the gearbox output shaft sealing periodically in accordance with the maintenance schedule, page 196.
2	Carefully remove deposits. Use lint-free cloths to clean the gearbox. NOTE: In case of a leakage, contact your local Schneider Electric service representative.

NOTICE

DAMAGED GEARBOXES DUE TO INAPPROPRIATE CLEANING OF THE GEARBOX

- Use lint-free cloth for cleaning.
- Do not clean dry deposits using compressed air.
- Do not use solvents; for example, trichloroethylene, tetrachloromethane, or hydrocarbons nor sharp-edged objects, emery cloth, or emery paper.
- Minimize the mechanical impacts when cleaning.

Failure to follow these instructions can result in equipment damage.

Cleaning

Overview

Care must be taken with cleaning products as some active agents may have harmful effects on plastics and stainless steel.

NOTICE

CORROSION CAUSED BY CLEANING AGENTS

- Perform a compatibility test in relation to the cleaning agent and the component affected before using a cleaning agent.
- Do not use alkaline detergent in the interior of the mechanics.
- Do not use any chloride-containing cleaning agents.
- Do not use any sulphuric acid containing detergent.

Failure to follow these instructions can result in equipment damage.

For further information about the material properties of your components, refer to *Mechanical and Electrical Data*, page 31.

NOTE: Depending on the operating conditions and requirements, cleaning may be necessary on a more frequent basis.

Cleaning the Robot

Step	Action
1	Use cleaning processes appropriate to the degree of protection, page 31 of the robot.
2	Allow the cleaning agent to act for a short time.
3	Thoroughly rinse the robot with water.
4	Clean the robot on a weekly basis in order to help to avoid that abrasions accumulate and pass into production.

Cleaning the Bearing of the Parallel Plate on Robots with a Rotational Axis (VRKP...R)

Clean the bearing according to the maintenance plan, page 196 and additionally in case of visible contamination.

Clean the bearing more frequently than specified if the robot is operated in a dusty environment.

NOTE: The bearing is a special bearing for dry operation. Slight squeaking noises are normal for this type of ball bearing.

Cleaning the Universal Joints

If contamination is visible, wet clean universal joints by washing or dry clean them by blowing out.

NOTE: Slide films are subject to abrasion which may accumulate.

Cleaning the Ball Sockets

If contamination is visible, wet clean ball sockets by washing or dry clean them by blowing out/wiping off.

NOTE: Do **not** lubricate the ball sockets; this increases the tendency to form accumulations of impurities in the bearing.

Cleaning the Gearbox

NOTE: Particularly in the first hours of operation, a slight sweating of the gearboxes may occur. This is a result of the manufacturing process and does not constitute damage on the gearboxes.

Only clean the gearbox flanges and seals by using wiping with lint-free clothes or wash-down at low pressure. For further information, refer to *Maintaining the Gearbox*, page 200.

Repairing After Collisions

Overview

Components may be damaged as a result of a collision.

⚠ WARNING

FALLING OR EJECTED PARTS

- Thoroughly inspect all components of the robot and all components attached to the robot, including the motor and the gearbox, for damage after a collision.
- Do not use the robot if any of the components are damaged or suspected to be damaged.

Failure to follow these instructions can result in death, serious injury, or equipment damage.

Verifying the Robot After a Collision

⚠ WARNING

COLLISION OF COMPONENTS

Replace upper and/or lower arms if dents or cracks are observed or otherwise detected.

Failure to follow these instructions can result in death, serious injury, or equipment damage.

Step	Action
1	Verify the components for completeness. If any components are missing, locate the same and remove them from the surrounding machinery.
2	Replace damaged or missing components.
3	Verify the upper and lower arms for visible dents or cracks. Dents reduce the strength of the arms and may cause component breakdown.
4	Verify the calibration, page 228 by moving the upper arms on the calibration bolts. NOTE: If the tolerance requirements for calibration are not met, replace the upper arms.
5	Verify the lower arms for straightness.
6	Release the brakes and manually move the robot to verify the ease of operation.
7	Close the brakes and verify that there is a small backlash in the gearboxes and no cracking noises.
8	Only for robots with a rotational axis (VRKP***R): Rotate the telescopic axis in order to verify that the bearing in the parallel plate runs evenly and smoothly. NOTE: If the bearing cannot be rotated evenly and/or produces noises during the rotation of the axis, proceed as follows: <ol style="list-style-type: none"> 1. Wash out the bearing in order to remove any foreign objects. 2. Verify the bearing again. NOTE: If the ceramic rolling elements of the hybrid bearing are damaged, replace the parallel plate.

In case of other repairs beyond those described in the present document, contact your local Schneider Electric service representative.

Replacing Parts

Information About Replacing Parts

Overview

The use and application of the information contained herein require expertise in the design and programming of automated control systems. Only you, the user, machine builder or integrator, can be aware of all the conditions and factors present during installation and setup, operation, repair, and maintenance of the machine or process.

You must also consider any applicable standards and/or regulations with respect to grounding of all equipment. Verify compliance with any safety information, different electrical requirements, and normative standards that apply to your machine or process in the use of this equipment.

⚠️⚠️ DANGER

ELECTRIC SHOCK, EXPLOSION, OR ARC FLASH

- Disconnect all power from all equipment including connected devices prior to removing any covers or doors, or installing or removing any accessories, hardware, cables, or wires except under the specific conditions specified in the appropriate hardware guide for this equipment.
- Always use a properly rated voltage sensing device to confirm the power is off where and when indicated.
- Operate electrical components only with a connected protective ground (earth) cable.
- Verify the secure connection of the protective ground (earth) cable to all electrical devices to ensure that connection complies with the connection diagram.
- Do not touch the electrical connection points of the components when the module is energized.
- Provide protection against indirect contact.
- Insulate any unused conductors on both ends of the motor cable.

Failure to follow these instructions will result in death or serious injury.

The robot heats up significantly when subjected to heavy loads and/or high performance.

The metal surfaces of the robot may exceed 70 °C (158 °F) during operation.

⚠️ WARNING

HOT SURFACES

- Avoid unprotected contact with hot surfaces.
- Do not allow flammable or heat-sensitive parts in the immediate vicinity of hot surfaces.
- Verify that the heat dissipation is sufficient by performing a test run under maximum load conditions.

Failure to follow these instructions can result in death, serious injury, or equipment damage.

For further information, refer to *Hot Surfaces*, page 17.

Replacing the Telescopic Axis

Overview

The following procedures describe the replacement of the telescopic axis as an example. The steps for the Telescopic Axis Double are similar.

Procedure Overview

Perform the following procedures to replace the telescopic axis:

- Removing the telescopic axis, page 204
- Mounting the telescopic axis, page 204

Removing the Telescopic Axis

⚠ CAUTION

HOT TELESCOPIC AXIS

- Allow the guides of the telescopic axis to cool down before touching them.
- Do not exceed the number of the prescribed extension and retraction manipulations to help avoid any melting of the slide bearings.

Failure to follow these instructions can result in injury or equipment damage.

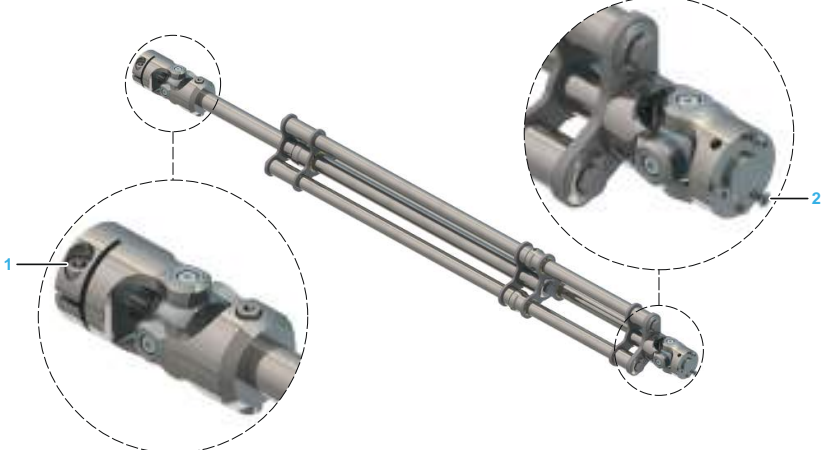
Step	Action
1	Remove the three countersunk screws (2) at the lower universal joint, which are located on the underside of the parallel plate. 
2	Loosen the clamping bolt (1) at the upper universal joint.
3	Remove the telescopic axis from the robot.

Mounting the Telescopic Axis

Step	Action
1	Mount the new telescopic axis, page 131. NOTE: When using a Telescopic Axis Double, refer to <i>Mounting the Telescopic Axis Double</i> , page 155.
2	Calibrate the telescopic axis, page 232.

Replacing the Universal Joints

Overview

The following procedures describe the replacement of the universal joints of the telescopic axis as an example. The steps for the Telescopic Axis Double are similar.

Replacing the Upper Universal Joint

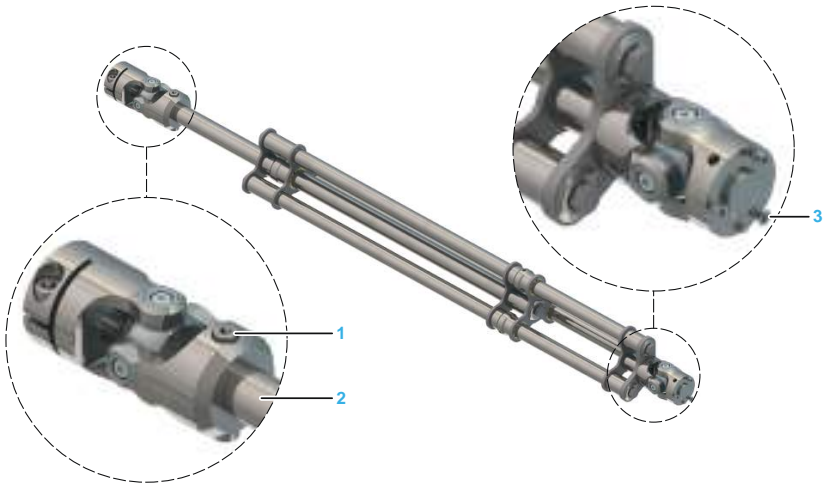
Step	Action
1	Remove the telescopic axis as described in <i>Replacing the Telescopic Axis</i> , page 204.
2	Remove the two mounting screws (1) and remove the universal joint from the upper tube (2). 
3	Attach the new universal joint to the upper tube.
4	Insert and tighten the two screws into the universal joint. Verify that the locating pin in the lower universal joint is in alignment with the screw M6 of the upper universal joint and the larger bore of the upper tube. Use the high strength retaining compound Loctite 648 for this purpose. Tightening torque: <ul style="list-style-type: none"> • For M6: 7 Nm (62 lbf-in) • For M5: 4 Nm (35.4 lbf-in) For further information, refer to <i>Telescopic Axis</i> , page 78. NOTE: Tightening torque when using the Telescopic Axis Double: <ul style="list-style-type: none"> • For M6: 5 Nm (44 lbf-in) • For M5: 3.5 Nm (31 lbf-in) For further information, refer to <i>Detail Drawing of the Telescopic Axis Double</i> , page 153.

Replacing the Lower Universal Joint

Step	Action
1	Remove the telescopic axis as described in <i>Replacing the Telescopic Axis</i> , page 204.
2	Remove the three screws (3) at the top of the lower universal joint and pull off the joint from the footbridge.

Step	Action
3	Attach the new universal joint to the footbridge.
4	<p>Insert and tighten the three screws into the universal joint. Verify that the locating pin in the lower universal joint is in alignment with the screw M6 of the upper universal joint and the larger bore of the upper tube. Use the high strength retaining compound Loctite 648 for this purpose.</p> <p>Tightening torque: 1 Nm (8.9 lbf-in)</p> <p>NOTE: Apply the high strength retaining compound Loctite 648 into the tapped holes as opposed to applying it to the screws.</p> <p>For further information, refer to <i>Telescopic Axis</i>, page 78.</p> <p>NOTE: Tightening torque when using the Telescopic Axis Double: 0.8 Nm (7.1 lbf-in)</p> <p>For further information, refer to <i>Detail Drawing of the Telescopic Axis Double</i>, page 153.</p>



Replacing the Plain Bearings

Procedure Overview

Perform the following procedures to replace the plain bearings:

- Removing the plain bearings, page 206
- Mounting the new plain bearings, page 208

Removing the Plain Bearings

Step	Action
1	Remove the telescopic axis, page 204.
2	Remove the upper and the lower universal joint from the telescopic axis as described in <i>Replacing the Universal Joints</i> , page 205.
3	<p>Remove the four screws and the four lock washers (1) from the axle bolts in each universal joint.</p> 
4	<p>Remove the four axle bolts (2) from each universal joint.</p>  <p>NOTE: If the axle bolts do not drop out, loosen the axle bolts by slightly screwing and moving a M5 screw into the axle bolt.</p>

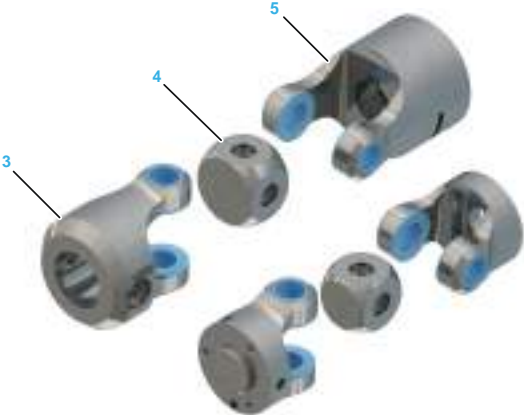
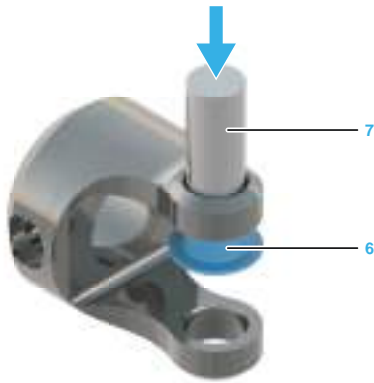
Step	Action
5	<p data-bbox="635 174 1404 230">Pull apart the two forks, (3) and (5), from each universal joint and remove the axis cuboids (4).</p>  <p data-bbox="758 246 1284 660">An exploded view diagram of universal joint components. It shows two large grey fork-like parts, labeled 3 and 5, and four smaller grey axis cuboids, labeled 4. The components are arranged to show their relative positions and how they fit together.</p>
6	<p data-bbox="635 678 1404 734">Press out the plain bearings (6) from the forks by using a cylindrical bolt (7) with a diameter of 11...11.5 mm (0.43...0.45 in).</p>  <p data-bbox="893 750 1268 1131">A close-up diagram showing a grey fork component. A blue cylindrical bolt, labeled 7, is being pushed into a hole in the fork. A blue plain bearing, labeled 6, is being pressed out of the hole. A blue arrow points downwards from the top of the bolt, indicating the direction of force.</p>

Mounting the New Plain Bearings

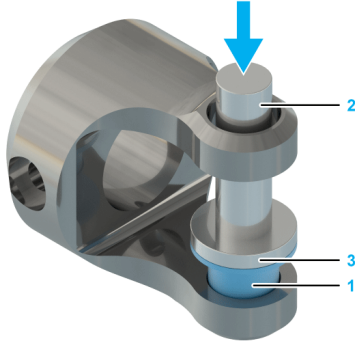
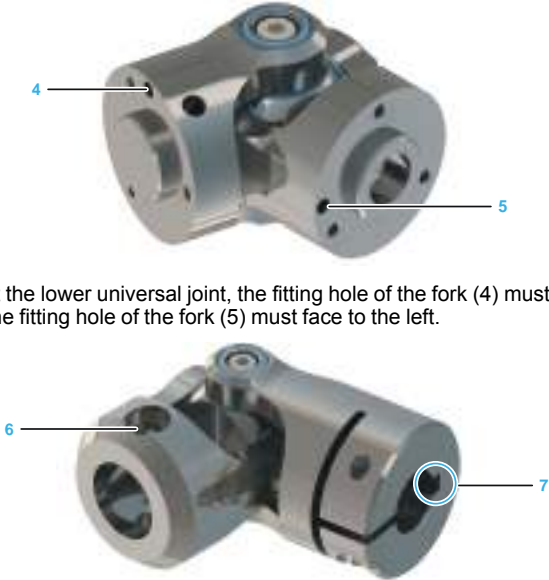
Step	Action
1	<p>Press in the new plain bearings (1) into the forks by using a cylindrical bolt (2) with a maximum diameter of 9.5 mm (0.374 in) and a plane disc (3). Ensure that the plain bearings are fully seated.</p> 
2	<p>Reassemble the universal joints in reverse order and verify that the orientation of the two forks is the same as shown in the figures below.</p> <p>Tightening torque for the screws: 3 Nm (26.6 lbf-in)</p>  <p>NOTE: At the lower universal joint, the fitting hole of the fork (4) must face to the top and the fitting hole of the fork (5) must face to the left.</p> <p>NOTE: At the upper universal joint, the hole for the larger screw M6 of fork (6) must face to the top and the hub of the fitted key of fork (7) must face to the right.</p>
3	<p>Mount the universal joints to the telescopic axis as described in <i>Replacing the Universal Joints</i>, page 205. Verify that the locating pin in the lower universal joint is in alignment with the screw M6 of the upper universal joint or also the larger bore of the upper tube.</p>
4	<p>Mount the telescopic axis as described in <i>Mounting the Telescopic Axis</i>, page 131.</p>
5	<p>Calibrate the telescopic axis depending on the necessary angle precision of the application.</p> <p>For further information, refer to <i>Calibrating the Rotational Axis</i>, page 232.</p>

Replacing the Slide Films

Overview

The following procedures describe the replacement of the slide films at the telescopic axis as an example. The steps for the Telescopic Axis Double are similar. Note the two lower tubes when handling the Telescopic Axis Double.

Procedure Overview

Perform the following procedures to replace the slide films:

- Removing the telescopic axis (refer to *Replacing the Telescopic Axis*, page 204)
- Disassembling the telescopic axis, page 209
- Replacing the slide films, page 210

Disassembling the Telescopic Axis

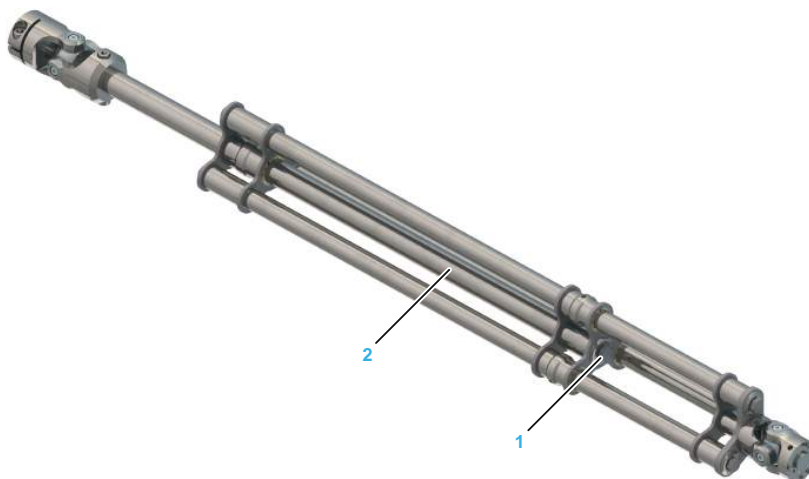

NOTE: When disassembling the telescopic axis, do not loosen or remove the bottom bolt (1) on the upper tube (2). This may allow the upper tube to be freely rotated. This causes the position of the gripper to be no longer in congruence with the previous position after the replacement of the slide film. In addition, this may cause a change in the position of the universal joints relative to one another. Both universal joints must be located exactly at the same position as shown in the detail drawing of the *Telescopic Axis*, page 78.

Step	Action
1	Remove both mounting screws (2) at the upper universal joint (1) in order to be able to separate the upper tube (6) and the universal joints. 
2	Remove the upper universal joint.
3	Remove the clamping on the three lower tubes (8) of the closure bridge (4) and release the self-blocking of the clamping sets by slightly tapping on the three clamping bolts (3).

Step	Action
4	Remove the closure bridge from the tubes.
5	Pull off the upper tube and the slide bridge (7) from the three outer tubes.

NOTICE

UNINTENDED GRIPPER POSITION

- Perform a renewed calibration of the rotational axis if the bottom bolt on the upper tube has been loosened or removed.
- Following the replacement of the slide films, do not join the upper tube and the lower tubes when these are twisted out of position by 180°.

Failure to follow these instructions can result in equipment damage.

Replacing the Slide Films

Step	Action
1	<p>Remove all four slide films (5) from the bearing points of the bridges and clean the bearing points if necessary.</p> 
2	Insert the new slide films into the bearings. Ensure that the index lugs located on the films engage correctly in the corresponding recesses of the bearing points.
3	Verify that the slide films are fully inserted into the bearing bores.
4	<p>Assemble the telescopic axis in reverse order and ensure that the universal joints are orientated correctly in relation to one another. The locating pin in the lower universal joint is in alignment with the larger screw (2) of the upper universal joint or also the larger bore of the upper tube (6).</p> <p>For further information about the necessary torques, refer to <i>Telescopic Axis</i>, page 78.</p> <p>NOTE: When using the Telescopic Axis Double, refer to <i>Detail Drawing of the Telescopic Axis Double</i>, page 153.</p>
5	<p>Mount the telescopic axis and calibrate it depending on the necessary angle precision of the application.</p> <p>For further information, refer to <i>Replacing the Telescopic Axis</i>, page 204 and <i>Calibrating the Robot Mechanics</i>, page 228.</p>

Replacing the Motor or the Gearbox on the Rotational Axis

Overview

The use and application of the information contained herein require expertise in the design and programming of automated control systems. Only you, the user, machine builder or integrator, can be aware of all the conditions and factors present during installation and setup, operation, repair, and maintenance of the machine or process.

You must also consider any applicable standards and/or regulations with respect to grounding of all equipment. Verify compliance with any safety information, different electrical requirements, and normative standards that apply to your machine or process in the use of this equipment.

DANGER

ELECTRIC SHOCK, EXPLOSION, OR ARC FLASH

- Disconnect all power from all equipment including connected devices prior to removing any covers or doors, or installing or removing any accessories, hardware, cables, or wires except under the specific conditions specified in the appropriate hardware guide for this equipment.
- Always use a properly rated voltage sensing device to confirm the power is off where and when indicated.
- Operate electrical components only with a connected protective ground (earth) cable.
- Verify the secure connection of the protective ground (earth) cable to all electrical devices to ensure that connection complies with the connection diagram.
- Do not touch the electrical connection points of the components when the module is energized.
- Provide protection against indirect contact.
- Insulate any unused conductors on both ends of the motor cable.

Failure to follow these instructions will result in death or serious injury.

Procedure Overview

Perform the following procedures to replace the motor or the gearbox on the rotational axis:

- Removing the motor and the gearbox, page 211
- Removing the motor from the gearbox, page 212
- Mounting the new motor and/or the new gearbox, page 213
- Cabling the motor and the gearbox, page 213
- Calibrating the robot and closing the housing, page 214

Removing the Motor and the Gearbox

NOTICE

LOSS OF IP65 DEGREE OF PROTECTION

Replace each sealing gasket every time you remove the media cover.

Failure to follow these instructions can result in equipment damage.

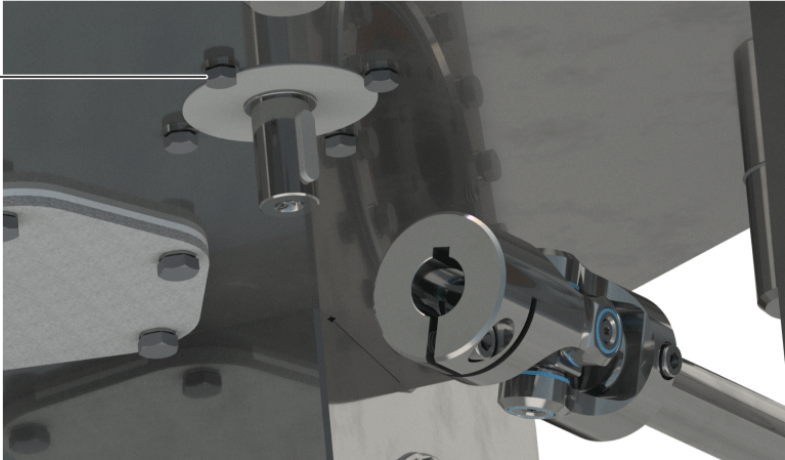
Step	Action
1	Remove the telescopic axis as described in <i>Replacing the Telescopic Axis</i> , page 204.
2	Remove the maintenance cover at the end of motor A. For further information on the position of the motor, refer to the detail drawing of the main body in <i>Mechanical and Electrical Data</i> , page 31.
3	Disconnect the motor supply cable. For further information, observe the respective operating instructions of the motors: <ul style="list-style-type: none"> • VRKP0 / VRKP1: <i>MH3 Servo motor Motor Manual</i> • VRKP2S0 / VRKP4S0 / VRKP5S0 / VRKP6S0: <i>SH3 Servo motor Motor Manual</i> • VRKP2L0 / VRKP4L0 / VRKP5L0 / VRKP6L0: <i>Lexium 62 ILM Hardware Guide</i>
4	Remove the hexagon cap from the ground connection at the motor.
5	Disconnect the ground cable.
6	Remove the four bolts (1) on the underside of the robot housing around the output shaft of the gearbox. 
7	Carefully pull the motor and the gearbox upwards.
8	Remove the motor and the gearbox from the robot housing.

Removing the Motor from the Gearbox

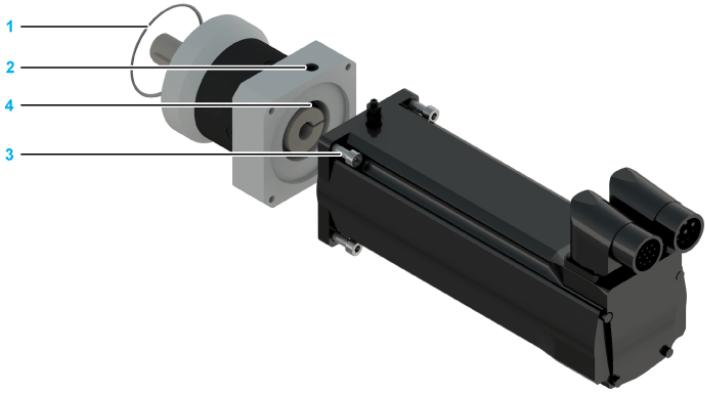
Step	Action
1	Remove the O-ring (1) from the gearbox flange. 
2	Remove the plug screw (2) from the gearbox flange.
3	Remove the four screws (3) at the motor by means of which the motor is attached to the gearbox.
4	Carefully rotate the motor until the screw (4) on the clamping ring appears in the aperture of the plug screw.

Step	Action
5	Loosen this screw.
6	Carefully remove the motor from the gearbox.

Mounting the New Motor and/or the New Gearbox

Step	Action
1	Ensure that the gearbox and the housing are at the same temperature, as otherwise - in the case of a temperature difference - the gearbox may not fit into the aperture provided.
2	Attach the motor to the gearbox according to the specifications of the manufacturer: <ul style="list-style-type: none"> • Tightening torque of the motor: 3.5 Nm (31 lbf-in) • Screw on the clamping ring: 4.5 Nm (40 lbf-in) <p>NOTE: Position the motor and the gearbox vertically during mounting if possible.</p>
3	Insert the plug screw into the gearbox flange.
4	Place a new O-ring to the gearbox.
5	Attach the motor/gearbox combination in the orientation specified to the robot housing. Tightening torque: 3.5 Nm (31 lbf-in) For further information, refer to the detail drawing in <i>Mechanical and Electrical Data</i> , page 31.
6	Use new sealing washers in order to maintain the leak tightness of the housing.

⚠ ⚠ DANGER

ELECTRIC SHOCK CAUSED BY INSUFFICIENT CONDUCTIVITY

Only use the bolts and bolt seals specified in order to maintain electric conductivity.

Failure to follow these instructions will result in death or serious injury.

NOTICE

DAMAGE TO MOTOR AND GEARBOX

Only fasten motor and gearbox with all components at the same ambient temperature.

Failure to follow these instructions can result in equipment damage.

Cabling the Motor and the Gearbox

Step	Action
1	Attach the ground strap to the motor. Tightening torque: 2.5 Nm (22 lbf-in) NOTE: When routing the cables, ensure that the grounding cap remains on the ground connection of the motors. The motor supply cable may become damaged by the thread of the ground strap attachment.
2	Put the hexagon cap on the ground connection at the motor. For further information, observe the respective operating instructions of the motors: <ul style="list-style-type: none"> • VRKP0 / VRKP1: <i>MH3 Servo motor Motor Manual</i> • VRKP2S0 / VRKP4S0 / VRKP5S0 / VRKP6S0: <i>SH3 Servo motor Motor Manual</i> • VRKP2L0 / VRKP4L0 / VRKP5L0 / VRKP6L0: <i>Lexium 62 ILM Hardware Guide</i>
3	Attach the motor supply cables and lock them in position.

Step	Action
4	Mount the telescopic axis as described in <i>Replacing the Telescopic Axis</i> , page 204.
5	Calibrate the robot mechanics, page 228.

⚡⚠ DANGER

ELECTRIC SHOCK DUE TO DAMAGED CABLES

Verify that the grounding cap is placed correctly on the grounding connection of the motor.

Failure to follow these instructions will result in death or serious injury.

Calibrating the Robot and Closing the Housing

NOTICE

LOSS OF IP65 DEGREE OF PROTECTION

Replace each sealing gasket every time you remove the maintenance cover(s).

Failure to follow these instructions can result in equipment damage.

Step	Action
1	Mount the telescopic axis as described in <i>Replacing the Telescopic Axis</i> , page 204.
2	Calibrate the robot mechanics, page 228.
3	Mount the maintenance cover. NOTE: Use a new seal in order to maintain the leak tightness of the housing. For further information, refer to the detail drawing in <i>Mechanical and Electrical Data</i> , page 31.

⚠ WARNING

COLLISION OF COMPONENTS

Calibrate the robot mechanics after the replacement of an upper arm, a motor, or a gearbox.

Failure to follow these instructions can result in death, serious injury, or equipment damage.

Replacing the Lower Arms

Step	Action
1	Grip one lower arm as close as possible to the ball socket and, for removal, pull the lower arm off the ball pin against the force of the spring.
2	Pull off the opposite arm from the ball pin.
3	Repeat the above steps for all lower arms.
4	Mount the new lower arms, page 133.

NOTICE

INOPERABLE EQUIPMENT

- For removing the lower arms, hold tight the parallel plate as this parallel plate may move as a result of the removal of one arm.
- Never grip lower arms in their center as otherwise the arms are bent during extension and must be replaced.

Failure to follow these instructions can result in equipment damage.

Replacing the Ball Sockets

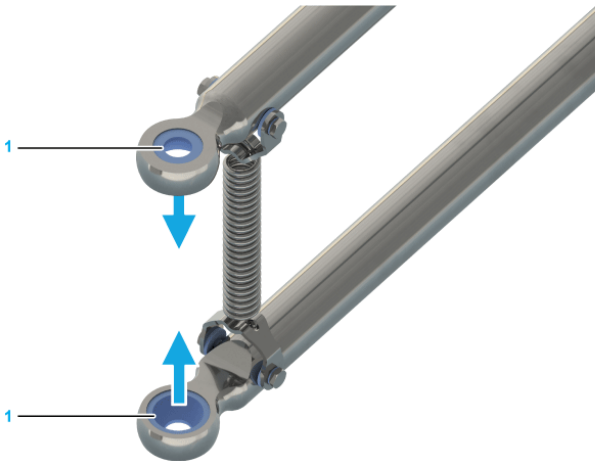
Step	Action
1	Remove the lower arms as described in <i>Replacing the Lower Arms</i> , page 214.
2	Press the ball sockets (1) in the direction of the arrow, and from the rear, out of the lower arm head. <div style="text-align: center; margin-top: 10px;">  </div>
3	Remove any abrasions from the lower arm head and the ball pin.
4	Press in a new ball socket from the front.
5	Replace the ball joints of the parallel plate and the upper arm if these show any damaged sections.
6	Verify after the replacement whether the lower arms are seated on the ball pins without any backlash. <p>NOTE: If there is some backlash on the lower arms, verify that the ball pin is evenly round and does not show any strongly run-in surface areas.</p>
7	<p>NOTE: Springs are also subject to wear.</p> When replacing the ball sockets, replace also the springs and the rolls. For further information on the springs, refer to <i>Maintaining the Springs</i> , page 197 and <i>Replacing the Springs</i> , page 215. For further information on the rolls, refer to <i>Maintaining the Rolls on the Spring Pack of the Lower Arm</i> , page 198.
8	Mount the lower arms, page 133.

Replacing the Springs

Step	Action
1	Remove the lower arms, page 214.
2	Push the springs off the spring brackets until the eyes have been unhooked.
3	Place the lower arms side by side.

Step	Action
4	With the open side of the eye, join the spring to the respective spring bracket.
5	Push the eyes of the springs into the spring brackets to completely embed the springs into the spring brackets.

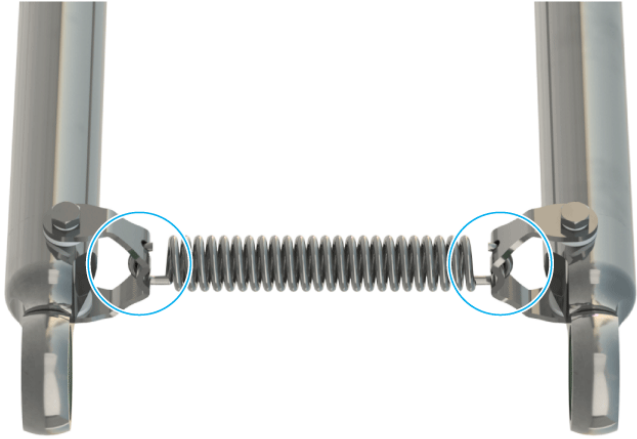

Replacing the Rolls on the Lower Arms

Procedure Overview

Perform the following procedures to replace the rolls on the lower arms:

- Removing the rolls, page 216
- Mounting the new rolls, page 217

Removing the Rolls

Step	Action
1	Remove the lower arms as described in <i>Replacing the Lower Arms</i> , page 214.
2	Unhook each spring (1) by pushing the spring against the direction of tension over a spring bracket (2).
3	Remove the spring brackets, the bolts (3), and the rolls (4). For further information, refer to <i>Replacing the Springs</i> , page 215.

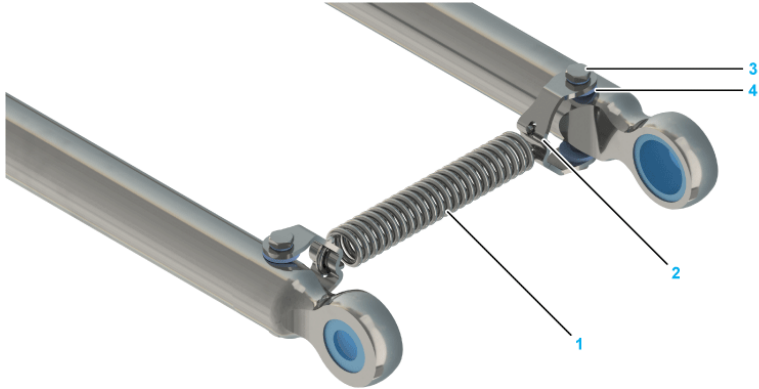

Mounting the New Rolls

NOTICE	
EJECTED PARTS	
Comply with the torques of the bolts so that the arms do not disengage from the robot.	
Failure to follow these instructions can result in equipment damage.	

Step	Action
1	Replace the rolls.
2	Tighten the spring brackets and the bolts. Tightening torque: 1 Nm (8.9 lbf-in)
3	Push the new springs to the spring brackets.
4	Mount the lower arms, page 133.

Replacing the Parallel Plate

Overview

The following figure shows the correct position of the parallel plate with bottom mounting points (1):

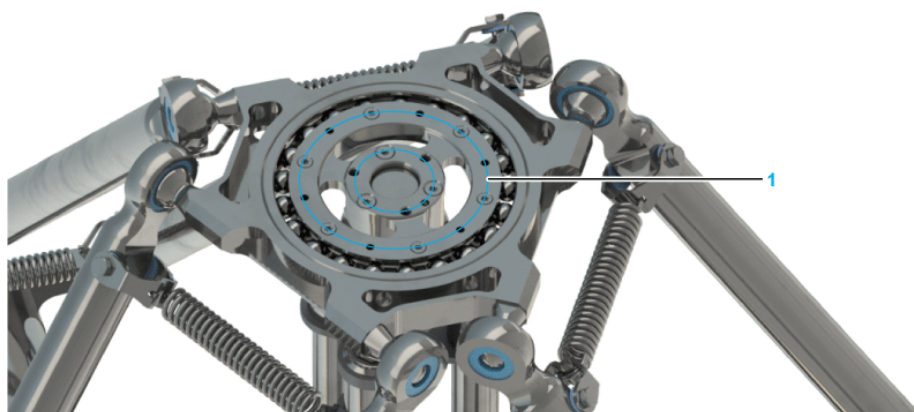

Replacing the Parallel Plate

Step	Action
1	Only for robots with a rotational axis (VRKP•••R): Remove the telescopic axis as described in <i>Replacing the Telescopic Axis</i> , page 204.
2	Remove the lower arms as described in <i>Replacing the Lower Arms</i> , page 214.
3	Hook in the new parallel plate with the lower arms. Ensure that the mounting side for the gripper is located at the underside, as shown in the figure above. NOTE: The mounting can be recognized by its threaded holes.
4	Only for robots with a rotational axis (VRKP•••R): Mount the telescopic axis as described in <i>Replacing the Telescopic Axis</i> , page 204. NOTE: The parallel plate can be rotated by $n \times 120^\circ$. Proceed with particular care in such cases to refit the parallel plate in its original position.
5	Only for robots with a rotational axis (VRKP•••R): Move the parallel plate slowly and verify the position of the gripper.

Replacing the Upper Arms

Procedure Overview

Perform the following procedures to replace an upper arm:

- Replacing the upper arm, page 218
- Calibrating and Reassembling robot, page 219

Replacing the Upper Arm

⚠ WARNING

FALLING HEAVY UPPER ARM

Secure in place the upper arm when loosening and removing the bolts.

Failure to follow these instructions can result in death, serious injury, or equipment damage.

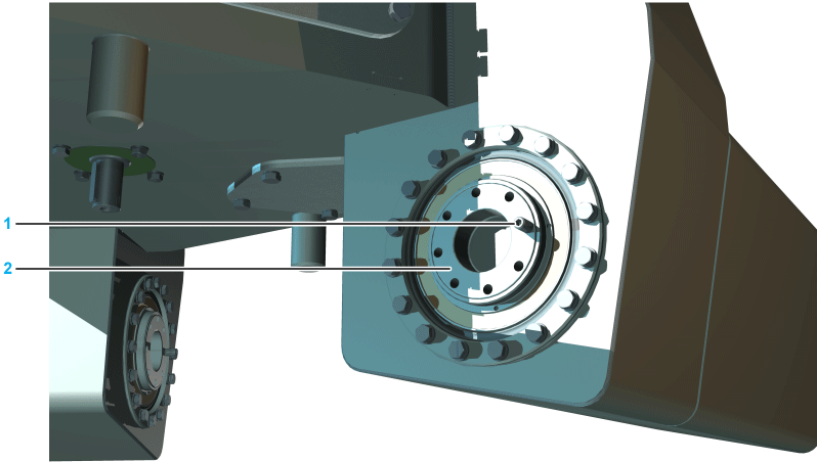
Step	Action
1	Remove the telescopic axis and the lower arms. For further information, refer to <i>Replacing the Telescopic Axis</i> , page 204 and <i>Replacing the Lower Arms</i> , page 214.
2	Remove the bolts at the upper arm.
3	Pull off the upper arm.
4	Verify whether the threaded pin (1) is in the hole of the gearbox. If there is no threaded pin, insert a new threaded pin at the position shown in the figure.  For further information, refer to the detail drawing of the main body in <i>Mechanical and Electrical Data</i> , page 31.
5	Verify whether the flange surfaces of the gearbox (2) and of the upper arm are free from grease and oil. If necessary, remove grease and oil residues from the upper arm.
6	Attach the new upper arm to the gearbox. Tightening torque: <ul style="list-style-type: none"> • For VRKP0 / VRKP1: 5 Nm (44.3 lbf-in) • For VRKP2 / VRKP4 / VRKP5 / VRKP6: 14 Nm (124 lbf-in)

NOTICE

INOPERABILITY OF UPPER ARM

Remove all grease and oil residues from the gearbox flange and the upper arm.

Failure to follow these instructions can result in equipment damage.

▲ WARNING
<p>COLLISION OF COMPONENTS</p> <p>Only use the bolts that are prescribed by Schneider Electric.</p> <p>Failure to follow these instructions can result in death, serious injury, or equipment damage.</p>

For further information on stud torques, bolt locking devices and installation notes, see the dimensional drawing in *Mechanical and Electrical Data*, page 31.

NOTE: To order the appropriate screws, contact your local Schneider Electric service representative.

Calibrating and Reassembling the Robot

Step	Action
1	Calibrate the robot mechanics, page 228.
2	Mount the telescopic axis and the lower arms. For further information, refer to <i>Replacing the Telescopic Axis</i> , page 204 and <i>Replacing the Lower Arms</i> , page 214.

▲ WARNING
<p>COLLISION OF COMPONENTS</p> <p>Calibrate the robot mechanics after the replacement of an upper arm, a motor, or a gearbox.</p> <p>Failure to follow these instructions can result in death, serious injury, or equipment damage.</p>

Replacing the Protector Cap

NOTICE
<p>INSUFFICIENT PART CLEARANCE</p> <p>Ensure that the protector cap does not touch the gearbox output shaft during assembly.</p> <p>Failure to follow these instructions can result in equipment damage.</p>

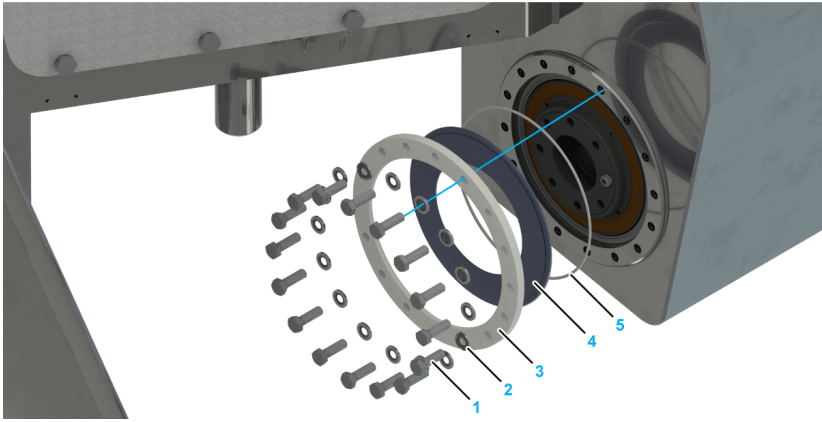
Step	Action
1	Remove the lower arms and the upper arms. For further information, refer to <i>Replacing the Lower Arms</i> , page 204 and <i>Replacing the Upper Arms</i> , page 218.
2	Remove the 16 screws (1) and washers (2) and then remove the supporting ring (3), the protector cap (4), and the O-ring (5) from each of the three housing flanges. 
3	Insert the new O-ring to the intended bevel edge of the new protector cap.
4	Place the protector cap with the O-ring to the new supporting ring.
5	Place the entire unit over the gearbox output shaft on the robot and fasten it with the new screws and the new sealing washers. NOTE: Ensure that the protector cap does not come into contact with the gearbox output shaft before tightening the screws. Tightening torque: 3.5 Nm (31 lbf-in)
6	Mount the upper arms and the lower arms. For further information, refer to <i>Replacing the Upper Arms</i> , page 218 and to <i>Mounting the Lower Arms</i> , page 133.
7	Calibrate the robot, page 228.

Replacing the Motor or the Gearbox on the Main Axis

Overview

The use and application of the information contained herein require expertise in the design and programming of automated control systems. Only you, the user, machine builder or integrator, can be aware of all the conditions and factors present during installation and setup, operation, repair, and maintenance of the machine or process.

You must also consider any applicable standards and/or regulations with respect to grounding of all equipment. Verify compliance with any safety information, different electrical requirements, and normative standards that apply to your machine or process in the use of this equipment.

⚠ ⚠ DANGER**ELECTRIC SHOCK, EXPLOSION, OR ARC FLASH**

- Disconnect all power from all equipment including connected devices prior to removing any covers or doors, or installing or removing any accessories, hardware, cables, or wires except under the specific conditions specified in the appropriate hardware guide for this equipment.
- Always use a properly rated voltage sensing device to confirm the power is off where and when indicated.
- Operate electrical components only with a connected protective ground (earth) cable.
- Verify the secure connection of the protective ground (earth) cable to all electrical devices to ensure that connection complies with the connection diagram.
- Do not touch the electrical connection points of the components when the module is energized.
- Provide protection against indirect contact.
- Insulate any unused conductors on both ends of the motor cable.

Failure to follow these instructions will result in death or serious injury.

Procedure Overview

Perform the following procedures to replace the motor or the gearbox on the main axis:

- Removing the motor and the gearbox, page 221
- Removing the motor from the gearbox, page 223
- Mounting the new motor and/or the new gearbox, page 224
- Cabling the motor and the gearbox, page 224
- Mounting the motor cover, page 226

Removing the Motor and the Gearbox

Certain variants have a protective motor cover in place that must be removed. The motor cover is heavy (approximately 5 kg (11 lb)), and could cause damage or injury if it were to fall during removal.

⚠ WARNING**FALLING HEAVY LOAD**

Support the motor and gearbox while removing.

Failure to follow these instructions can result in death, serious injury, or equipment damage.

⚠ CAUTION**FALLING MOTOR COVER**

Hold the motor cover in place while loosening the screws.

Failure to follow these instructions can result in injury or equipment damage.

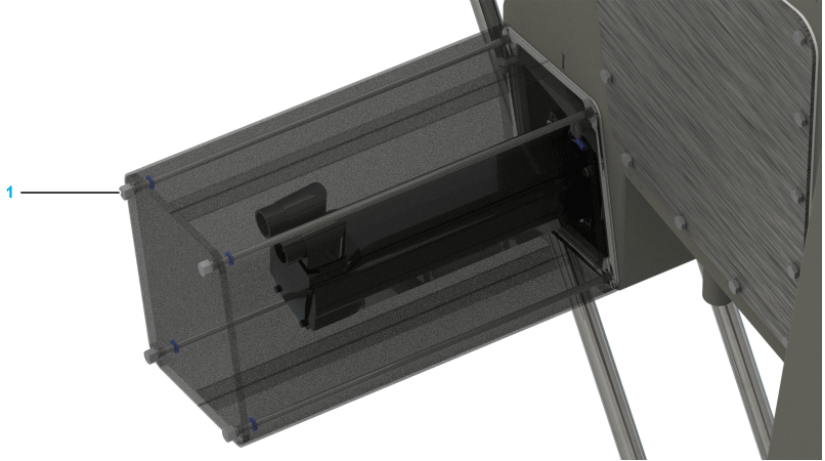
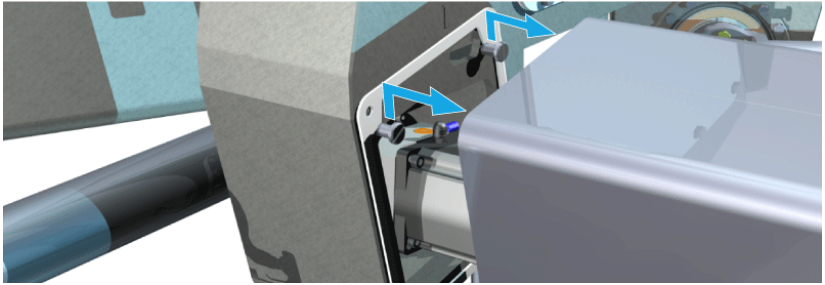
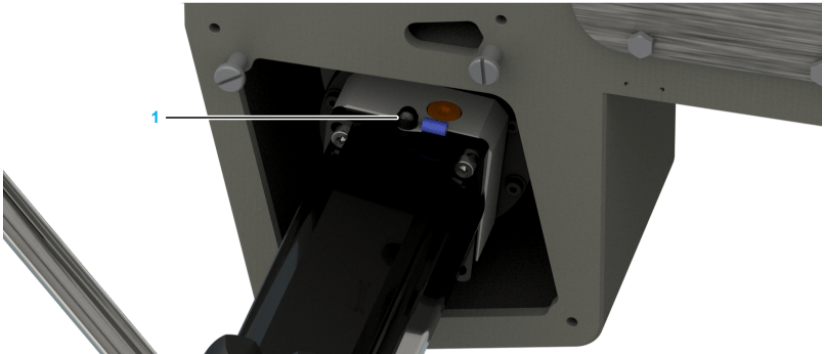
Step	Action
1	Remove the upper arm as described in <i>Replacing the Upper Arms</i> , page 218.
2	<p>Loosen the four threaded rods (1) at the rear end of the motor cover.</p> 
3	<p>Lift the motor cover slightly and remove to the rear.</p> 
4	<ul style="list-style-type: none"> • For robots with an SH3 motor (VRKP•S): Disconnect and remove the two motor supply cables. • For robots with an ILM motor (VRKP•L): Lift up the locking device slightly of the hybrid cable and then remove the cable.
5	<p>Remove the hexagon cap (1) from the ground connection at the motor.</p> 
6	Disconnect and remove the ground cable from the motor.

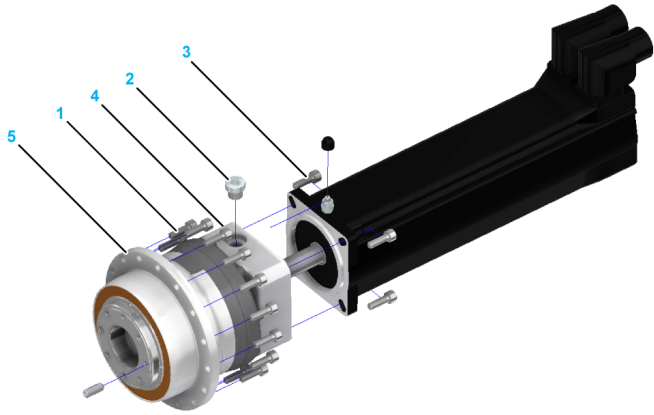
Step	Action
7	Remove the bolts (1) by means of which the gearbox is bolted to the robot housing. 
8	Carefully remove the motor and the gearbox (5) from the housing in rearward direction. NOTE: To prevent a damage of the precision hole in the robot housing, do not tilt the gearbox.

Removing the Motor from the Gearbox

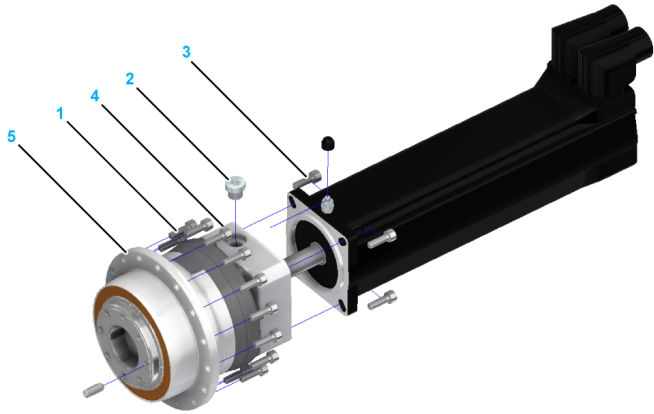
Step	Action
1	Remove the plug screw (2) on the gearbox flange. 
2	Remove the four screws (3) on the motor which connect the motor to the gearbox.
3	Carefully rotate the motor until the screw (4) on the clamping flange appears in the aperture of the plug screw.
4	Loosen this screw.
5	Carefully remove the motor from the gearbox.

Mounting the New Motor and/or the New Gearbox

Step	Action
1	Ensure that the gearbox and the housing are at the same temperature, as otherwise - in the case of a temperature difference - the gearbox may not fit into the aperture provided.
2	Attach the motor to the gearbox according to the specifications of the manufacturer: <ul style="list-style-type: none"> • Tightening torque of the clamping hub: <ul style="list-style-type: none"> ◦ For VRKP0 / VRKP1: 5 Nm (44 lbf-in) ◦ For VRKP2 / VRKP4 / VRKP5 / VRKP6: 9.5 Nm (84 lbf-in) • Tightening torque of the motor screws: 3.5 Nm (31 lbf-in) <p>NOTE: Position the motor and the gearbox vertically during mounting if possible.</p>
3	Insert the plug screw into the gearbox flange.
4	Attach the motor/gearbox combination in the orientation specified to the robot housing. Tightening torque: <ul style="list-style-type: none"> • For VRKP0 / VRKP1: 3 Nm (26 lbf-in) • For VRKP2 / VRKP4 / VRKP5 / VRKP6: 4.7 Nm (42 lbf-in) For further information, refer to the detail drawing in <i>Mechanical and Electrical Data</i> , page 31.

NOTICE

DAMAGE TO MOTOR AND GEARBOX

Only fasten motor and gearbox with all components at the same ambient temperature.

Failure to follow these instructions can result in equipment damage.

Cabling the Motor and the Gearbox

Step	Action
1	Attach the ground strap to the motor. Tightening torque: 2.5 Nm (22 lbf-in) NOTE: When routing the cables, ensure that the grounding cap remains on the ground connection of the motors. The motor supply cable may become damaged by the thread of the ground strap attachment.
2	Put the hexagon cap on the ground connection at the motor. For further information, observe the respective operating instructions of the motors: <ul style="list-style-type: none"> • VRKP2S0 / VRKP4S0 / VRKP5S0 / VRKP6S0: <i>SH3 Servo motor Motor Manual</i> • VRKP2L0 / VRKP4L0 / VRKP5L0 / VRKP6L0: <i>Lexium 62 ILM Hardware Guide</i>
3	Attach the motor supply cables and lock them in position.
4	Attach a new seal (quad ring) on the front between gearbox and housing by exercising light pressure to press the seal between the housing and the gearbox. NOTE: Do not use any sharp-edged tools so as not to damage the seal.

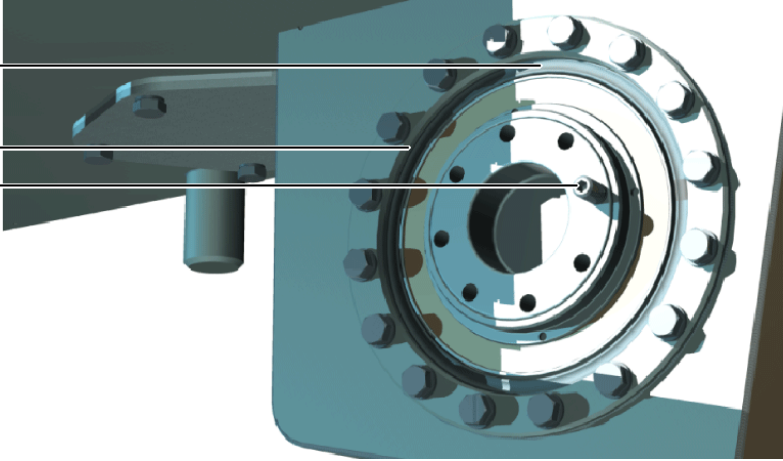
Step	Action
5	<p>Verify that the seal (1) does not stand out over the gearbox or the housing.</p> 
6	<p>When using a new gearbox:</p> <p>Mount the threaded pin (3) as otherwise it may not be possible to mount the upper arm.</p> <p>For further information, refer to the detail drawing in <i>Mechanical and Electrical Data</i>, page 31.</p>
7	<p>Mount the upper arm as described in <i>Replacing the Upper Arms</i>, page 218.</p>
8	<p>Calibrate the robot mechanics, page 228.</p>

⚠️⚠️ DANGER

ELECTRIC SHOCK DUE TO DAMAGED CABLES

Verify that the grounding cap is placed correctly on the grounding connection of the motor.

Failure to follow these instructions will result in death or serious injury.

⚠️ WARNING

COLLISION OF COMPONENTS

Calibrate the robot mechanics after the replacement of an upper arm, a motor, or a gearbox.

Failure to follow these instructions can result in death, serious injury, or equipment damage.

Mounting the Motor Cover

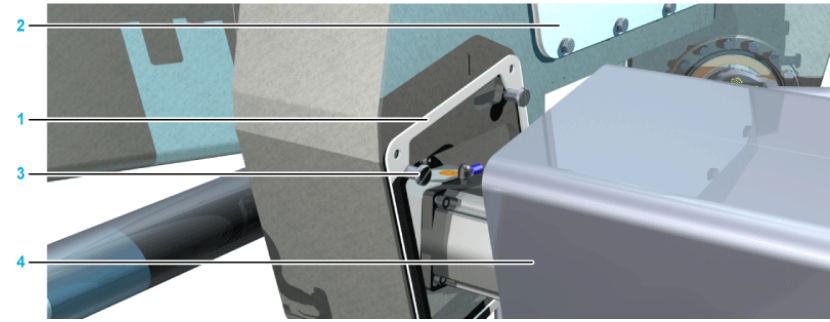
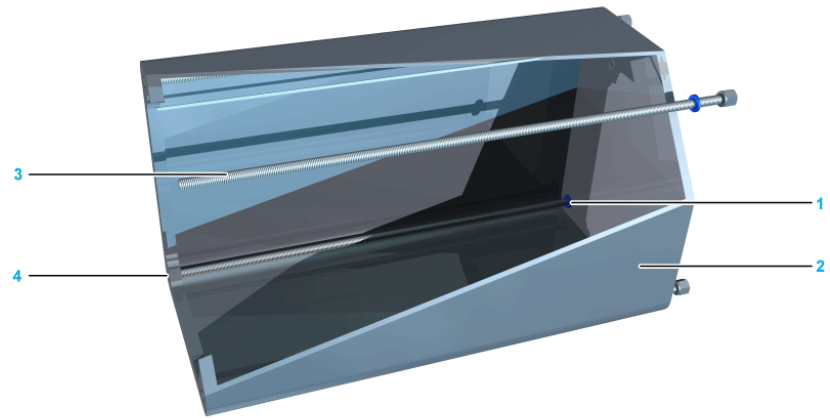
Step	Action
1	<p>Attach a new seal (1) on the capture screws (3) for the motor cover (4), as the old seal may cause leakages to occur between the housing and the motor cover.</p> 
2	<p>Verify the position of the captive washers (1). The captive washers should be located in the rear of the motor cover (2) on the threaded rods (3).</p> <p>NOTE: The captive washers should be placed so that the threaded rods can not drop out from the aperture of the motor cover (4).</p> 
3	Correct the position of the captive washers on the threaded rod if necessary.
4	Verify whether any open cables exist and remove them, if any.
5	<p>Hook the motor cover on the capture screws and tighten the four threaded rods at the motor cover.</p> <p>Tightening torque: 6 Nm (53.1 lbf-in)</p>
6	<p>Mount the telescopic axis and the lower arms.</p> <p>For further information, refer to <i>Replacing the Telescopic Axis</i>, page 204 and <i>Mounting the Lower Arms</i>, page 133.</p>

Replacing the Ball Pins

Step	Action
1	Remove the lower arms as described in <i>Replacing the Lower Arms</i> , page 214.
2	Unscrew the ball pins from the parallel plate and/or the upper arm.
3	Clean the holes.
4	<p>Mount the new ball pins to the parallel plate and/or the upper arm. Use the medium strength threadlocking adhesive Loctite 243 for this purpose.</p> <p>Tightening torque: 8.6 Nm (75 lbf-in).</p>
5	Mount the lower arms as described in <i>Replacing the Lower Arms</i> , page 214.

▲ WARNING**COLLISION OF ROBOT COMPONENTS**

- Verify the flush fitting with the contact surface and the correct use of the bolt locking device.
- Maintain the correct tightening torque.

Failure to follow these instructions can result in death, serious injury, or equipment damage.

Replacing the Fans

Procedure Overview

Perform the following procedures to replace the fans:

- Removing the fans, page 227
- Mounting the new fans, page 227

Removing the Fans

Step	Action
1	Remove the maintenance cover and the motor cover as described in <i>Opening the Robot</i> , page 110.
2	Disconnect the fan wires from the internal strip.
3	Remove the four fastening clips by putting them out from main motor side.
4	Remove the fans from the robot housing.

Mounting the New Fans

Step	Action
1	Insert the fans into the robot housing. For further information about the position of the fans, refer to the detail drawings in <i>Mechanical and Electrical Data</i> , page 31.
2	Fasten the fastening clips to the robot housing.
3	Connect the fan wires to the internal strip. For further information, refer to the cabling definition in <i>Electrical Installation</i> , page 110.
4	Mount the maintenance cover and motor cover as described in <i>Closing the Robot</i> , page 126.

Replacing the Gearbox Leakage Protection (Optional Equipment)

Step	Action
1	Remove the motor/gearbox combination from the robot housing, page 221.
2	Remove the threaded pin from the gearbox flange.
3	Mount the Gearbox Leakage Protection, page 147.
4	Connect the motor as described in <i>Cabling the Motor and the Gearbox</i> , page 224.
5	Mount the upper arm as described in <i>Replacing the Upper Arms</i> , page 218.
6	Calibrate the robot mechanics, page 228.
7	Mount the motor cover, page 226.

⚠ WARNING**COLLISION OF COMPONENTS**

Calibrate the robot mechanics after the replacement of an upper arm, a motor, or a gearbox.

Failure to follow these instructions can result in death, serious injury, or equipment damage.

Replacing the Motorized Module

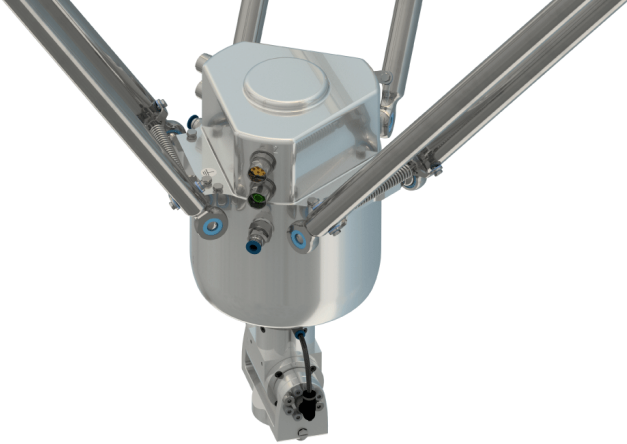
Step	Action
1	Remove the lower arms as described in <i>Replacing the Lower Arms</i> , page 214.
2	<p>Mount the new module with the lower arms. When hooking in the module, ensure that the mounting for the gripper is located on the underside, as shown in the figure below.</p> <p>NOTE: The Rotational Module, the Tilting Module, the Double Rotational Module, and the Rotational Tilting Module can be rotated by $n \times 120^\circ$. Mount the respective module in its original position. See important information below this table.</p> 
3	Move the module slowly and verify the position of the gripper.

Mounting the module in other than the original position will lead to inaccurate positioning.

NOTICE**DAMAGE DUE TO INCORRECT POSITIONING**

Verify that the mounting position of the module is consistent with the original position.

Failure to follow these instructions can result in equipment damage.

Calibration**Calibration of the Robot Mechanics****Overview**

The robot has been calibrated in the factory and the data/positions of the axes can be read from the motor encoders. A further alignment is not necessary. However, in a service case, calibration via the control panel may become necessary in order to restore the intended operation.

Carry Out the Calibration

Carry out the calibration in the following cases:

- Following the replacement of a component (motor, gearbox, upper arm).
- Following deletion or overwriting of the calibration data.

Calibrating the robot mechanics must be carried out by Schneider Electric personnel or qualified personnel only, as this requires an expert level of knowledge of the PacDrive System.

For this purpose, the `SchneiderElectricRobotics` library contains an interface that has the necessary modes and parameters.

⚠ WARNING
<p>UNINTENDED EQUIPMENT OPERATION</p> <ul style="list-style-type: none"> • Calibrating the robot mechanics must be carried out by qualified personnel only. • Conduct the calibration procedures exactly in the manner and in the order described in the present documentation. • Use the <code>SchneiderElectricRobotics</code> library in conjunction with the calibration of robot mechanics. <p>Failure to follow these instructions can result in death, serious injury, or equipment damage.</p>

Calibrating the Main Axes

Preparing the Robot Mechanics for a Calibration Movement

Step	Action
1	Remove the rotational axis (if present), the lower arms, and the parallel plate. For further information, refer to <i>Replacing the Telescopic Axis</i> , page 204, <i>Replacing the Lower Arms</i> , page 214, and <i>Replacing the Parallel Plate</i> , page 217.
2	Do not move the upper arms beyond their vertical downward position (1) in order to prevent the individual robot arms from colliding with one another during their calibration travel (2).

Sequence of the Calibration Process

Calibrate each of the three main axis motors by using the function *HomeOnTorque* for moving the ball pin of the upper arm to the calibration bolts (1).

The following figure shows the upper arm of the robot VRKP1/VRKP2 at the calibration position:

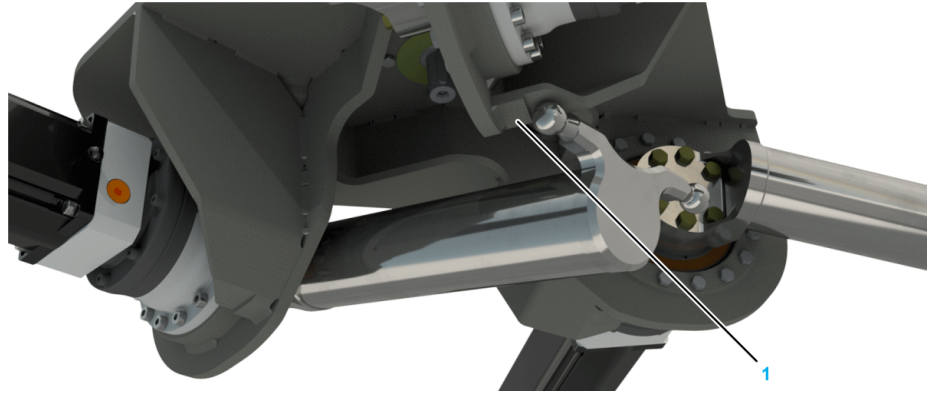

The following figure shows the upper arm of the robot VRKP0/VRKP4/VRKP5/VRKP6 at the calibration position:

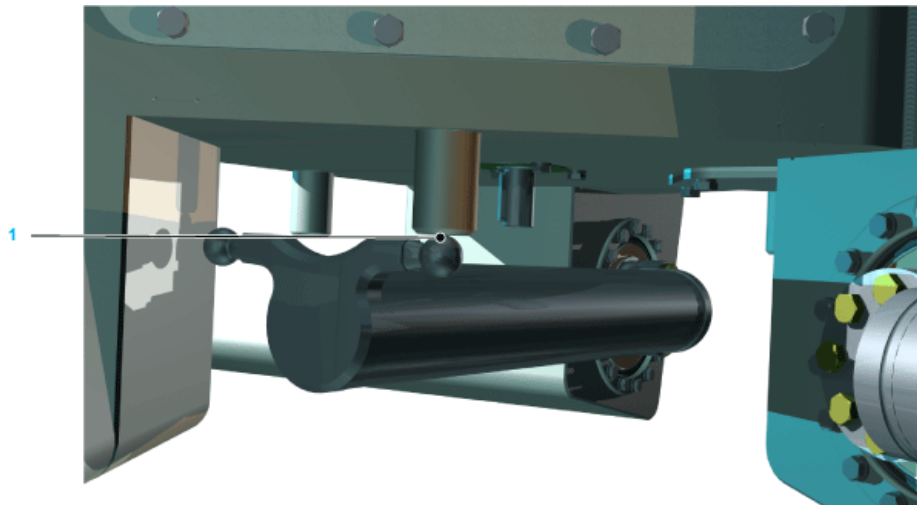

NOTE: Due to the preset offset, the calibration travel ends with the upper arms being in a vertical and downward-oriented position. Here, the ball pin (1) and not the tube of the upper arm are in vertical alignment with the center (2) of the gearbox (see the figure below).

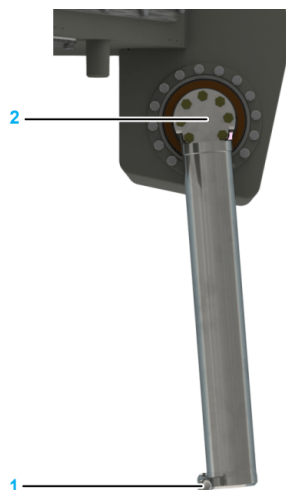

Verifying the Calibration

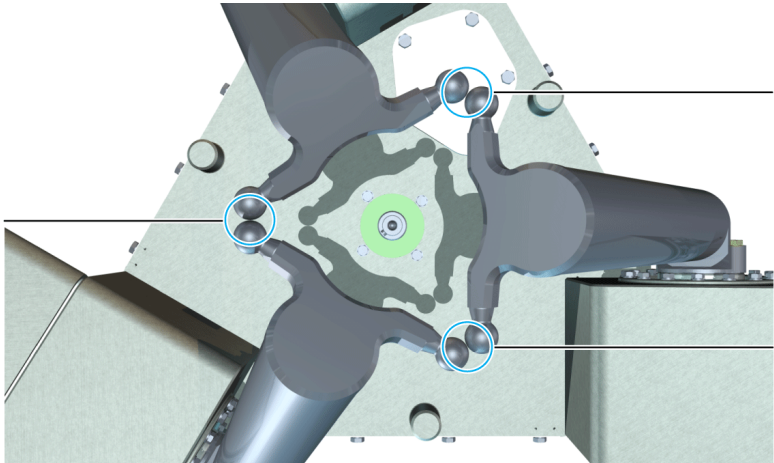
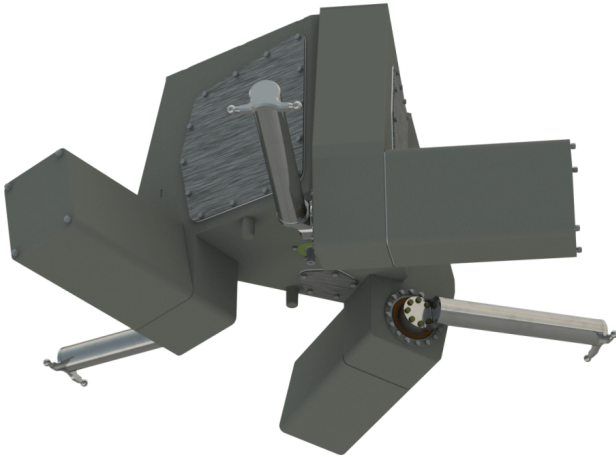
Step	Action
1	<p>Move all three upper arms to the following angle in order to verify the calibration:</p> <ul style="list-style-type: none"> • For VRKP0: -119.57° • For VRKP1: -112.72° • For VRKP2: -113.49° • For VRKP4: -119.76° • For VRKP5: -127.85° • For VRKP6: -123.35°
2	<p>Measure whether the gap between the ball pins (1) of the individual upper arms is larger than 0.6 mm (0.236 in).</p>  <p>If the gap is larger than required or ball pins collide, proceed as follows:</p> <ol style="list-style-type: none"> 1. Verify that all parameters (motor direction of rotation, gearbox factor) are correctly set in the controller configuration and correct these parameters if necessary. 2. Verify that the following components are not damaged and replace any damaged parts if necessary: <ul style="list-style-type: none"> • Upper arms (for example, bent, twisted, dented) • Drives (for example, damaged gearbox, loose clamping hub between gearbox and motor, damaged motor encoder) 3. Repeat the calibration travel.
3	<p>Perform one of the following actions:</p> <ul style="list-style-type: none"> • Move the upper arms - within the permitted angle position - into a basic position (for example, 0°, see the following figure) • Release the brakes and move the arms into the required position.  <p>Result: The robot is now calibrated.</p>
4	<p>Mount the lower arms, the parallel plate, and the telescopic axis if applicable.</p> <p>For further information, refer to <i>Mounting the Lower Arms</i>, page 133, <i>Replacing The Parallel Plate</i>, page 217, and <i>Mounting the Telescopic Axis</i>, page 131.</p>

Calibrating the Rotational Axis

Step	Action
1	Move and align the rotational axis (and robot) in a clearly defined position in the working range of the machine (for example, put a plane surface of the mounted gripping device against an existing edge).
2	<p>Describe the motor of the rotational axis by using the following parameters:</p> <pre> astControlled[ROB_GE_CA_ADDX_1].stHome.etMode := TPD_GE_HOME_RESTOREPOS_FROM_AXISENCODER; astControlled[ROB_GE_CA_ADDX_1].stHome.stHomeWritePos.lrPos := 0.0; astControlled[ROB_GE_CA_ADDX_1].stHome.stHomeWritePos.lrPeriod := 0.0; astControlled[ROB_GE_CA_ADDX_1].stHome.stHomeWritePos.lrAbsEncOffset := 500.0; astControlled[ROB_GE_CA_ADDX_1].stHome.stHomeSetpos.lrPos := 0.0; astControlled[ROB_GE_CA_ADDX_1].stHome.stHomeSetpos.lrEncoderPos := 0.0; astControlled[ROB_GE_CA_ADDX_1].stHome.stHomeSetpos.lrAbsEncOffset := 500.0; astControlled[ROB_GE_CA_ADDX_1].stHome.stHomeSetpos.lrRestoreWindow := 180; astControlled[ROB_GE_CA_ADDX_1].stHome.stHomeSetpos.lrPeriod := 0; </pre> <p>NOTE: This code is an example. The values can vary depending on the application.</p>

Calibrating the Double Rotational Module or the Rotational Tilting Module (Optional Equipment)

Overview

For calibrating the fourth and the fifth axis of the Double Rotational Modules or the Rotational Tilting Modules, use the applied markings. Align the markings to each other as presented in the following figures.

Calibration Markings at the Fourth Axis

For calibrating the fourth axis of the Double Rotational Modules and the Rotational Tilting Modules, use the markings presented in the following figure.

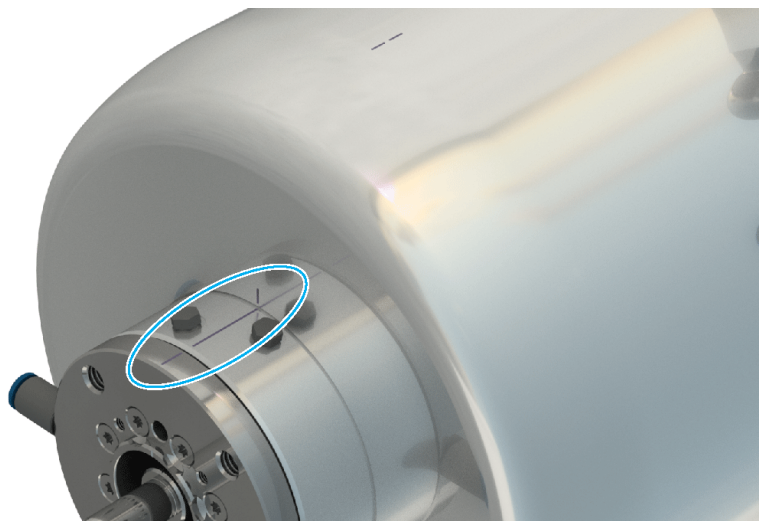

Calibration Markings at the Fifth Axis

For calibrating the fifth axis of the Double Rotational Modules, use the markings presented in the following figure.



For calibrating the fifth axis of the Rotational Tilting Modules, use the markings presented in the following figure.

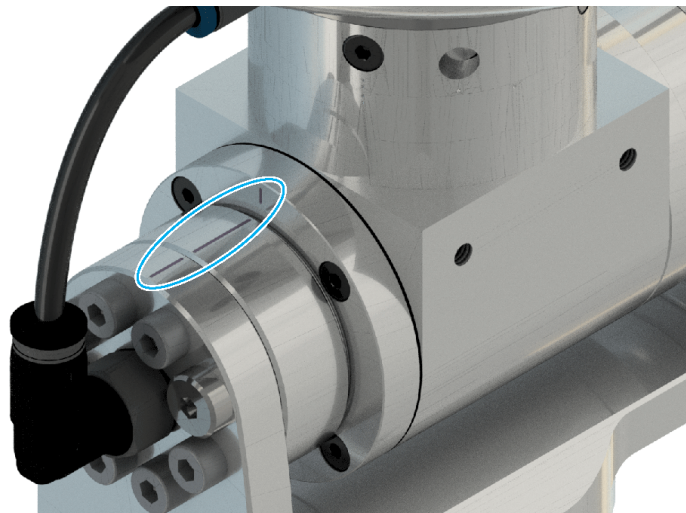

Calibrating the Tilting Module (Optional Equipment)

Adjusting the Rotation Angle of the Tilting Axis

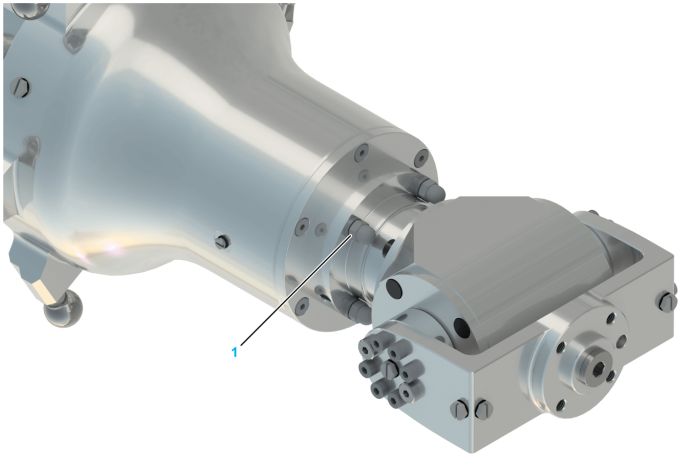
Step	Action
1	Loosen the four nuts (1). 
2	Adjust the required angle by rotating the tilting gearbox. NOTE: The adjustment angle range is 40°.
3	Tighten the four nuts. Tightening torque: 3.5 Nm (31 lbf-in)

Calibration Markings at the Tilting Axis

For calibrating the tilting axis, align the applied markings to each other as presented in the following figure.

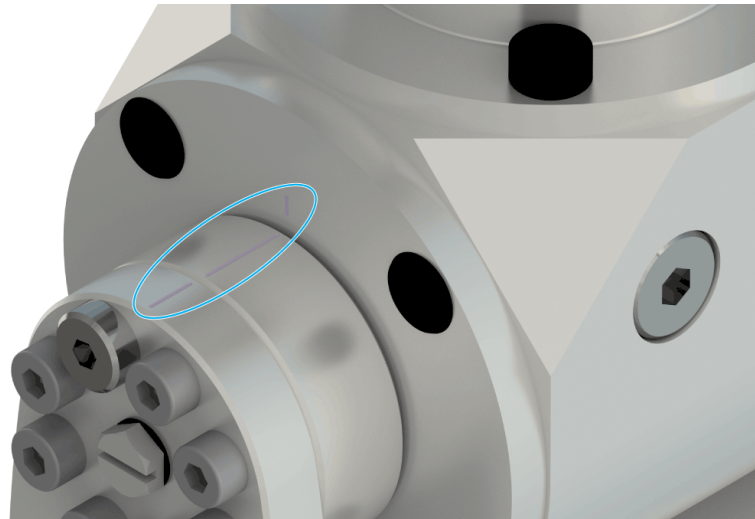

Replacement Equipment and Accessories

What's in This Chapter

Replacement Equipment Inventory 235
 Standard Replacement Equipment 238
 Optional Equipment and Accessories..... 244

Replacement Equipment Inventory

Overview

Keeping a stock of important components helps ensure the availability of your machine. Only exchange devices with identical types to help ensure compatibility.

Indicate the following information on the replacement equipment order, which can be found on the logistic type plate, page 28:

Parameter	Example value	Position on type plate
Item name	Robot P4I-R-NO-15-1200	First line
Item reference (type code)	VRKP4L0RNO00000	ID-No
Hardware revision	S00	HW

Replacement Equipment Stock for Robots without a Rotational Axis

When using the Lexium P robot in a production environment, consider keeping the following replacement equipment packages in stock:

Item reference	Item name	Quantity*								
		VRKP0	VRK-P-0.....-E00	VRKP1	VRK-P-1.....-E00	VRKP2	VRKP4	VRKP5	VRKP6	VRK-P-6.....-E00
VRKP0YYYYY00002	Upper arm	(1)**	(1)**	0	0	0	0	0	0	0
VRKP1YYYYY00002		0	0	(1)**	(1)**	0	0	0	0	0
VRKP2YYYYY00002		0	0	0	0	(1)**	0	0	0	0
VRKP4YYYYY00002		0	0	0	0	0	(1)**	0	0	0
VRKP5YYYYY00002		0	0	0	0	0	0	(1)**	0	0
VRKP6YYYYY00002		0	0	0	0	0	0	0	(1)**	(1)**
VRKP1YYYYY00003	Gearbox main axis	(1)**	(1)**	(1)**	(1)**	0	0	0	0	0
VRKP4YYYYY00003		0	0	0	0	(1)**	(1)**	(1)**	(1)**	(1)**
VRKP4YYYYY00006	Parallel plate with ball pins	(1)**	(1)**	(1)**	(1)**	(1)**	(1)**	(1)**	(1)**	(1)**
VRKP4YYYYY00024	Ball pins - set of 12	(1)**	(1)**	(1)**	(1)**	(1)**	(1)**	(1)**	(1)**	(1)**
VRKP4YYYYY00025	Ball sockets - set of 12	1	1	1	1	1	1	1	1	1
VRKP4YYYYY00028	Fan	0	0	0	0	(1)***	(1)***	(1)***	(1)***	(1)***
VRKP1YYYYY00032	Springs - set of 6	1	1	1	1	0	0	0	0	0
VRKPXYYYYY00032		0	0	0	0	1	1	1	1	1

Item reference	Item name	Quantity*								
		VRKP0	VRK-P-0.....-E00	VRKP1	VRK-P-1.....-E00	VRKP2	VRKP4	VRKP5	VRKP6	VRK-P-6.....-E00
VRKP0YYYYY00037	Lower arm pair	1 (2)**	0	0	0	0	0	0	0	0
VRKP1YYYYY00037		0	1 (2)**	1 (2)**	0	0	0	0	0	0
VRKP2YYYYY00037		0	0	0	1 (2)**	1 (2)**	0	0	0	0
VRKP4YYYYY00037		0	0	0	0	0	1 (2)**	0	0	0
VRKP5YYYYY00037		0	0	0	0	0	0	1 (2)**	0	0
VRKP6YYYYY00037		0	0	0	0	0	0	0	1 (2)**	0
VRKP6YYYYY00E37		0	0	0	0	0	0	0	0	1 (2)**

* When using more than one robot, increase the amount accordingly.

** Only if there are increased requirements on the availability of the machine.

*** Only for robots VRKP2...WD / VRKP4L0•WD / VRKP4L0•NO / VRKP4S0•WF / VRKP5S0•WF / VRKP6S0•WF with increased requirements on the availability of the machine.

Replacement Equipment Stock for Robots with a Rotational Axis

When using the Lexium P robots in a production environment, consider keeping the following replacement equipment packages in stock:

Item reference	Item name	Quantity*								
		VRKP0	VRK-P-0.....-E00	VRKP1	VRK-P-1.....-E00	VRKP2	VRKP4	VRKP5	VRKP6	VRK-P-6.....-E00
VRKP0YYYYY00002	Upper arm	(1)**	(1)**	0	0	0	0	0	0	0
VRKP1YYYYY00002		0	0	(1)**	(1)**	0	0	0	0	0
VRKP2YYYYY00002		0	0	0	0	(1)**	0	0	0	0
VRKP4YYYYY00002		0	0	0	0	0	(1)**	0	0	0
VRKP5YYYYY00002		0	0	0	0	0	0	(1)**	0	0
VRKP6YYYYY00002		0	0	0	0	0	0	0	(1)**	(1)**
VRKP1YYYYY00003	Gearbox main axis	(1)**	(1)**	(1)**	(1)**	0	0	0	0	0
VRKP4YYYYY00003		0	0	0	0	(1)**	(1)**	(1)**	(1)**	(1)**
VRKP4YYYYY00029	Parallel plate with bearing and ball pins	(1)**	(1)**	(1)**	(1)**	(1)**	(1)**	(1)**	(1)**	(1)**
VRKP4YYYYY00012	Slide films - three sets of three	1	1	1	1	1	1	1	1	1
VRKP4YYYYY00024	Ball pins - set of 12	(1)**	(1)**	(1)**	(1)**	(1)**	(1)**	(1)**	(1)**	(1)**
VRKP4YYYYY00025	Ball sockets - set of 12	1	1	1	1	1	1	1	1	1
VRKP4YYYYY00028	Fan	0	0	0	0	(1)***	(1)***	(1)***	(1)***	(1)***
VRKP1YYYYY00032	Springs - set of 6	1	1	1	0	0	0	0	0	0
VRKPXYYYYY00032		0	0	0	1	1	1	1	1	1

Item reference	Item name	Quantity*								
		VRKP0	VRK-P-0.....-E00	VRKP1	VRK-P-1.....-E00	VRKP2	VRKP4	VRKP5	VRKP6	VRK-P-6.....-E00
VRKP0YYYYY00033	Telescopic axis	(1)**	0	0	0	0	0	0	0	0
VRKP0YYYYY00E33		0	(1)**	0	0	0	0	0	0	0
VRKP1YYYYY00033		0	0	(1)**	0	0	0	0	0	0
VRKP1YYYYY00E33		0	0	0	(1)**	0	0	0	0	0
VRKP2YYYYY00033		0	0	0	0	(1)**	0	0	0	0
VRKP4YYYYY00033		0	0	0	0	0	(1)**	0	0	0
VRKP5YYYYY00033		0	0	0	0	0	0	(1)**	0	0
VRKP6YYYYY00033		0	0	0	0	0	0	0	(1)**	0
VRKP6YYYYY00E33		0	0	0	0	0	0	0	0	(1)**
VRKP0YYYYY00037	Lower arm pair	1 (2)**	0	0	0	0	0	0	0	0
VRKP1YYYYY00037		0	1 (2)**	1 (2)**	0	0	0	0	0	0
VRKP2YYYYY00037		0	0	0	1 (2)**	1 (2)**	0	0	0	0
VRKP4YYYYY00037		0	0	0	0	0	1 (2)**	0	0	0
VRKP5YYYYY00037		0	0	0	0	0	0	1 (2)**	0	0
VRKP6YYYYY00037		0	0	0	0	0	0	0	1 (2)**	0
VRKP6YYYYY00E37		0	0	0	0	0	0	0	0	1 (2)**
VRKPXYYYYY00040	Plain bearing	1	1	1	1	1	1	1	1	1
VRKPXYYYYY00043	Upper universal joint	1	1	1	1	1	1	1	1	1
VRKPXYYYYY00044	Lower universal joint	1	1	1	1	1	1	1	1	1

* When using more than one robot, increase the quantity accordingly.

** Only if there are increased requirements on the availability of the machine.

*** Only for robots VRKP4L0•WD / VRKP4L0•NO / VRKP4S0•WF / VRKP5S0•WF / VRKP6S0•WF with increased requirements on the availability of the machine.

Replacement Equipment Stock for Robots with a Motorized Module

When using the Lexium P robots in a production environment, consider keeping the following replacement equipment packages in stock:

Item reference	Item name	Quantity*								
		VRKP0	VRK-P-0.....-E00	VRKP1	VRK-P-1.....-E00	VRKP2	VRKP4	VRKP5	VRKP6	VRK-P-6.....-E00
VRKP0YYYYY00002	Upper arm	(1)**	(1)**	0	0	0	0	0	0	0
VRKP1YYYYY00002		0	0	(1)**	(1)**	0	0	0	0	0
VRKP2YYYYY00002		0	0	0	0	(1)**	0	0	0	0
VRKP4YYYYY00002		0	0	0	0	0	(1)**	0	0	0
VRKP5YYYYY00002		0	0	0	0	0	0	(1)**	0	0
VRKP6YYYYY00002		0	0	0	0	0	0	0	(1)**	(1)**
VRKP1YYYYY00003	Gearbox main axis	(1)**	(1)**	(1)**	(1)**	0	0	0	0	0
VRKP4YYYYY00003		0	0	0	0	(1)**	(1)**	(1)**	(1)**	(1)**
VRKP4YYYYY00024	Ball pins - set of 12	(1)**	(1)**	(1)**	(1)**	(1)**	(1)**	(1)**	(1)**	(1)**
VRKP4YYYYY00025	Ball sockets - set of 12	1	1	1	1	1	1	1	1	1
VRKP4YYYYY00028	Fan	0	0	0	0	(1)**	(1)**	(1)**	(1)**	(1)**
VRKP1YYYYY00032	Springs - set of 6	1	1	1	1	0	0	0	0	0
VRKPXYYYYY00032		0	0	0	0	1	1	1	1	1
VRKP0YYYYY00037	Lower arm pair	1 (2)**	0	0	0	0	0	0	0	0
VRKP1YYYYY00037		0	1 (2)**	1 (2)**	0	0	0	0	0	0
VRKP2YYYYY00037		0	0	0	1 (2)**	1 (2)**	0	0	0	0
VRKP4YYYYY00037		0	0	0	0	0	1 (2)**	0	0	0
VRKP5YYYYY00037		0	0	0	0	0	0	1 (2)**	0	0
VRKP6YYYYY00037		0	0	0	0	0	0	0	1 (2)**	0
VRKP6YYYYY00E37		0	0	0	0	0	0	0	0	1 (2)**
VRKPXYYYYY00045		Rotational Module B	0	0	0	0	0	(1)**	0	0

* When using more than one robot, increase the amount accordingly.



** Only if there are increased requirements on the availability of the machine.





*** Only for robots VRKP2...WD / VRKP4L0...WD / VRKP4L0...NO / VRKP4S0...WF / VRKP5S0...WF / VRKP6S0...WF with increased requirements on the availability of the machine.

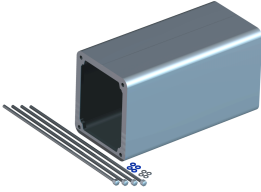
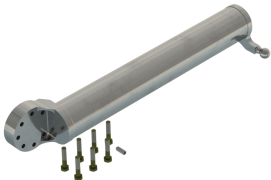
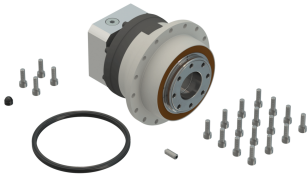
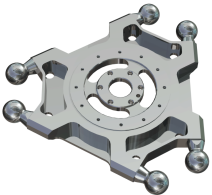

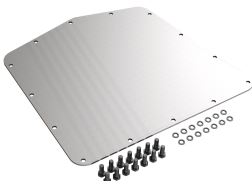

Standard Replacement Equipment

Overview

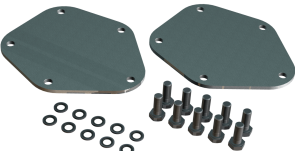
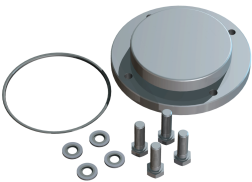
This following table presents the standard replacement equipment for the serial version of the Lexium P robot. For optional equipment, refer to *Optional Equipment and Accessories*, page 244.

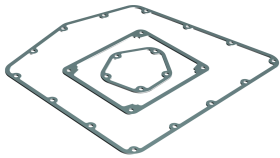



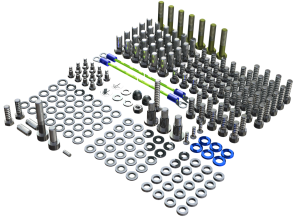
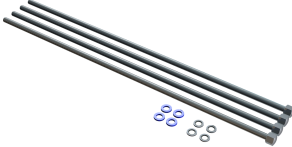
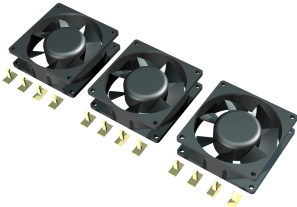
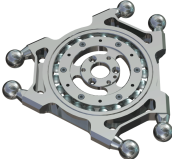

Item description and content	Representation	Item reference	To be used for
<p>Motor cover with fasteners - without sealing:</p> <ul style="list-style-type: none"> • 1x motor cover VRKP4***WD • 4x threaded rod • 4x sealing washer • 4x captive washer 		<p>VRKP4YYYYY00001</p>	<p>VRKP2***WD VRKP4***WD VRKP4***NO VRKP4***CW VRKP4***WF VRKP5***WF VRKP6***WF</p>
<p>Upper arm with ball pins, indexing bolt, and fasteners:</p> <ul style="list-style-type: none"> • 1x upper arm complete • 1x indexing bolt gearbox • 7x titanium screw upper arm 		<p>VRKP0YYYYY00002</p>	<p>VRKP0</p>
		<p>VRKP1YYYYY00002</p>	<p>VRKP1</p>
		<p>VRKP2YYYYY00002</p>	<p>VRKP2</p>
		<p>VRKP4YYYYY00002</p>	<p>VRKP4</p>
		<p>VRKP5YYYYY00002</p>	<p>VRKP5</p>
<p>Gearbox for the main axis with fasteners and indexing bolt:</p> <ul style="list-style-type: none"> • 1x gearbox main axis • 16x screw gearbox to housing • 16x lock washer gearbox to housing • 4x screw motor to gearbox • 1x indexing bolt gearbox • 1x quad ring • 1x grounding cap for motor 		<p>VRKP1YYYYY00003</p>	<p>VRKP0 VRKP1</p>
		<p>VRKP4YYYYY00003</p>	<p>VRKP2 VRKP4 VRKP5 VRKP6</p>
<p>Titanium parallel plate with ball pins:</p> <ul style="list-style-type: none"> • 1x titanium parallel plate complete 		<p>VRKP4YYYYY00006</p>	<p>All Lexium P robots</p>
<p>Guiding tubes for the telescopic axis:</p> <ul style="list-style-type: none"> • 3x lower tube • 1x upper tube 		<p>VRKP0YYYYY00010</p>	<p>VRKP0</p>
		<p>VRKP0YYYYY00E10</p>	<p>VRKP0*****E00</p>
		<p>VRKP1YYYYY00010</p>	<p>VRKP1</p>
		<p>VRKP1YYYYY00E10</p>	<p>VRKP1*****E00</p>
		<p>VRKP2YYYYY00010</p>	<p>VRKP2</p>
		<p>VRKP4YYYYY00010</p>	<p>VRKP4</p>
		<p>VRKP5YYYYY00010</p>	<p>VRKP5</p>
		<p>VRKP6YYYYY00E10</p>	<p>VRKP6*****E00</p>
<p>Miscellaneous fasteners for the telescopic axis:</p> <ul style="list-style-type: none"> • 1x clamping cone large • 1x clamping sleeve large • 1x washer large • 6x washer small • 6x clamping cone small • 6x clamping sleeve small • 1x cover universal joint • 7x screw clamping • 1x screw universal joint large • 1x screw universal joint small • 6x countersunk head screw universal joint • 2x straight pin universal joint 		<p>VRKP4YYYYY00011</p>	<p>All Lexium P robots</p>

Item description and content	Representation	Item reference	To be used for
<p>Standard slide films, three sets:</p> <ul style="list-style-type: none"> • 3x slide film 20 • 9x slide film 16 		VRKP4YYYYY00012	All Lexium P robots
<p>Gearbox for the rotational axis with fasteners and sealings:</p> <ul style="list-style-type: none"> • 1x gearbox rotational axis • 1x O-ring rotational motor • 4x sealing washer rotational motor • 4x screw motor to gearbox • 4x screw gearbox rotational axis to housing 		VRKP4YYYYY00014	All Lexium P robots
<p>Maintenance cover with fasteners:</p> <ul style="list-style-type: none"> • 1x maintenance cover • 14x screws maintenance cover • 14x sealing washer maintenance cover 		VRKP4YYYYY00015	VRKP2...WD VRKP4...WD VRKP4...NO VRKP4...CW
<p>Cable gland with covers and fasteners:</p> <ul style="list-style-type: none"> • 1x cable gland M16 PVDF • 1x counter nut M16 • 1x sealing ring PE M16 • 2x cable gland M50 PVDF • 2x counter nut M50 • 2x sealing ring PE M50 • 1x sealing insert 4x13 • 1x sealing insert 4x7 • 1x lock bolt 13 • 1x lock bolt 7 • 1x media cover 50 • 1x media cover 50/16 • 10x screw media cover • 10x sealing washer for screw media cover 		VRKP4YYYYY00016	VRKP2...WD VRKP4S0•WD / VRKP4S0•NO / VRKP4S0•CW
<p>Motor cover with fasteners - without sealing:</p> <ul style="list-style-type: none"> • 1x motor cover VRKP4...NO • 4x threaded rod • 4x sealing washer for threaded rod • 4x lock washer 		VRKP4YYYYY00017	VRKP4...WD VRKP4...NO VRKP4...CW
<p>Media covers with fasteners - without sealings:</p> <ul style="list-style-type: none"> • 2x media cover blank • 10x screw media cover • 10x sealing washer for screw media cover 		VRKP4YYYYY00018	VRKP2...WD VRKP4...WD VRKP4...NO VRKP4...CW VRKP4...WF
<p>Closing for the rotational axis, cover with fasteners and sealing:</p> <ul style="list-style-type: none"> • 1x cover rotational axis • 1x O-ring central motor • 4x sealing washer central motor • 4x screw cover rotational axis 		VRKP4YYYYY00019	VRKP2...WD VRKP4...WD VRKP4...NO VRKP4...CW VRKP4...WF

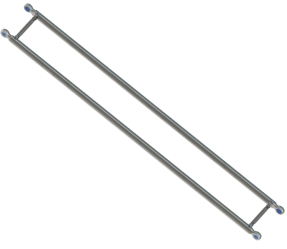
Item description and content	Representation	Item reference	To be used for
Sealing set for the maintenance cover, motor cover, and media cover: <ul style="list-style-type: none"> • 1x sealing gasket maintenance cover • 1x sealing gasket motor cover • 1x sealing gasket media cover 		VRKP4YYYYY00020	VRKP2...WD VRKP4...WD VRKP4...NO VRKP4...CW
Sealings for gearboxes, two sets: <ul style="list-style-type: none"> • 6x quad ring main axis motor • 2x O-ring rotational axis motor 		VRKP4YYYYY00021	VRKP2...WD VRKP4...WD VRKP4...NO VRKP4...CW VRKP4...WF
Screw set for one upper arm: <ul style="list-style-type: none"> • 7x screw upper arm 		VRKP1YYYYY00022	VRKP0 VRKP1
		VRKP4YYYYY00022	VRKP2 VRKP4 VRKP5 VRKP6
Ball pin set for one robot: <ul style="list-style-type: none"> • 12x ball pins 		VRKP4YYYYY00024	All Lexium P robots
Ball socket set for one robot: <ul style="list-style-type: none"> • 12x ball sockets 		VRKP4YYYYY00025	All Lexium P robots

Item description and content	Representation	Item reference	To be used for
<p>Set of small parts (for example, screws, washers, nuts) without expendable parts:</p> <ul style="list-style-type: none"> • 12x bolt lower arm • 2x sticker ground connection • 25x sealing washer for rotational motor / covering housing • 35x sealing washer for maintenance cover / media cover / motor cover • 2x washer for ground connection • 2x bolt for rotational motor • 10x screw for rotational motor to gearbox/ main motor to gearbox / universal joint small • 7x titanium bolt for upper arm • 1x straight pin universal joint • 1x clamping screw universal joint plastic • 2x screw for universal joint large / clamping universal joint titan • 3x countersunk head screw for universal joint • 30x screw for gearbox to housing • 30x lock washer for gearbox to housing • 25x bolt for rotational motor / covering housing • 2x indexing bolt for gearbox • 2x nut for ground connection • 1x spring ring for ground connection • 1x bolt for ground connection • 30x bolt for maintenance cover / media cover / clamping • 3x flat head screw for motor cover • 6x captive washer for motor cover • 2x grounding cap for motor 		VRKP1YYYYY00026	VRKP0 VRKP1
		VRKP4YYYYY00026	VRKP2 VRKP4 VRKP5 VRKP6
<p>Fasteners for the motor cover:</p> <ul style="list-style-type: none"> • 4x threaded rod • 4x sealing washer for threaded rod • 4x lock washer 		VRKP4YYYYY00027	VRKP2...WD VRKP4...WD VRKP4...NO VRKP4...CW VRKP4...WF VRKP5...WF VRKP6...WF
<p>Fans with fastening clips:</p> <ul style="list-style-type: none"> • 12x fastening clips • 3x fan 80x25 24 V • 6x wire ends 		VRKP4YYYYY00028	VRKP2...WD VRKP4...WD VRKP4...NO VRKP4...CW VRKP4...WF VRKP5...WF VRKP6...WF
<p>Titanium parallel plate with bearing and ball pins:</p> <ul style="list-style-type: none"> • 1x titanium parallel plate complete 		VRKP4YYYYY00029	All Lexium P robots





Item description and content	Representation	Item reference	To be used for
PacDrive motor for the rotational axis: <ul style="list-style-type: none"> 1x motor 		MH30701P02F2200	VRKP0S0R VRKP1S0R VRKP4S0RWF VRKP5S0RWF VRKP6S0RWF
		SH30702P02F2000	VRKP2S0R VRKP4S0R VRKP5S0R VRKP6S0R
PacDrive motor for the main axis: <ul style="list-style-type: none"> 1x motor 		SH30553P02F2000	VRKP0 VRKP1
		SH30703P02F2000	VRKP2 VRKP4 VRKP5 VRKP6
PacDrive motor for the main axis, Lexium 62 ILM: <ul style="list-style-type: none"> 1x motor 		ILM0703P02F0000	VRKP2 VRKP4 VRKP5 VRKP6
PacDrive motor for the rotational axis, Lexium 62 ILM: <ul style="list-style-type: none"> 1x motor 		ILM0702P02F0000	VRKP2 VRKP4 VRKP5 VRKP6
Springs, spring brackets, rolls and fasteners. Set for one robot: <ul style="list-style-type: none"> 6x spring 12x spring bracket 24x roll 24x screw 		VRKP1YYYYY00032	VRKP0 VRKP0.....E00 VRKP1
		VRKPXXXXXX00032	VRKP1.....E00 VRKP2 VRKP4 VRKP5 VRKP6
Telescopic axis with universal joints: <ul style="list-style-type: none"> 1x telescopic axis complete 		VRKP0YYYYY00033	VRKP0
		VRKP0YYYYY00E33	VRKP0.....E00
		VRKP1YYYYY00033	VRKP1
		VRKP1YYYYY00E33	VRKP1.....E00
		VRKP2YYYYY00033	VRKP2
		VRKP4YYYYY00033	VRKP4
		VRKP5YYYYY00033	VRKP5
		VRKP6YYYYY00033	VRKP6
VRKP6YYYYY00E33	VRKP6.....E00		



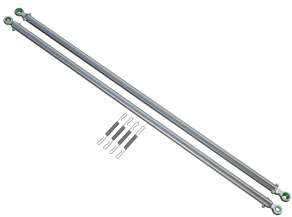
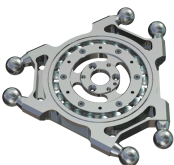
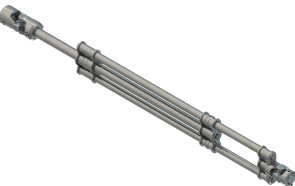

Item description and content	Representation	Item reference	To be used for
Lower arm pair with rolls, sockets, and springs: <ul style="list-style-type: none"> • 2x lower arm complete • 2x single spring 		VRKP0YYYYY00037	VRKP0
		VRKP1YYYYY00037	VRKP0.....E00 VRKP1
		VRKP2YYYYY00037	VRKP1.....E00 VRKP2
		VRKP4YYYYY00037	VRKP4
		VRKP5YYYYY00037	VRKP5
		VRKP6YYYYY00037	VRKP6
		VRKP6YYYYY00E37	VRKP6.....E00
Protector Cap for the main axes with fasteners. Set for one robot: <ul style="list-style-type: none"> • 3x protector cap • 3x supporting ring • 3x O-ring for Protector Cap • 48x screw for Protector Cap • 48x sealing washer 		VRKP1YYYYY00030	VRKP0 VRKP1
		VRKPXYYYYY00030	VRKP2 VRKP4 VRKP5 VRKP6
Plain bearings for the titanium universal joints of the telescopic axis: <ul style="list-style-type: none"> • 10x plain bearing • 1x thrust washer • 8x counter sunk screw M3 • 8x cylinder head screw M4 • 8x lock washer M4 		VRKPXYYYYY00040	All Lexium P robots
Titanium upper universal joint with fasteners: <ul style="list-style-type: none"> • 1x upper universal joint titanium • 1x clamping screw upper universal joint 		VRKPXYYYYY00043	All Lexium P robots
Titanium lower universal joint with fasteners and indexing bolt: <ul style="list-style-type: none"> • 1x lower universal joint titanium • 6x countersunk screw universal joint • 2x straight pin universal joint 		VRKPXYYYYY00044	All Lexium P robots
Sealing set for the maintenance cover, motor cover, and media cover: <ul style="list-style-type: none"> • 7x sealing gasket maintenance cover and motor cover • 1x sealing gasket media cover 		VRKPXYYYYY00051	VRKP4S0•WF VRKP5S0•WF VRKP6S0•WF



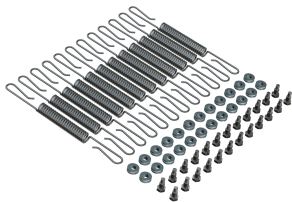
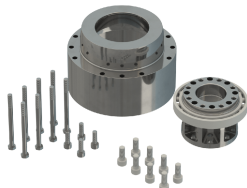

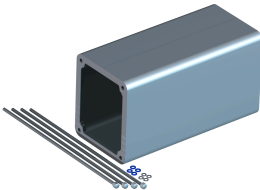

Optional Equipment and Accessories

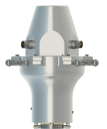
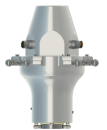
Overview

This section presents the optional equipment and accessories for the Lexium P robot. For the standard replacement equipment, refer to *Standard Replacement Equipment*, page 238.

Item description and content	Representation	Item reference	To be used for
Lower arms pair with rolls, sockets, and springs: <ul style="list-style-type: none"> • 2x lower arm complete • 4x springs 		VRKP2YYYYY00004 VRKP4YYYYY00004 VRKP5YYYYY00004 VRKP6YYYYY00004 VRKP6YYYYY00E04	VRKP2 VRKP4 VRKP5 VRKP6 VRKP6.....E00
Stainless steel parallel plate with bearing and ball pins: <ul style="list-style-type: none"> • 1x stainless steel parallel plate complete 		VRKP4YYYYY00005	All Lexium P robots
Telescopic Axis Double with universal joints: <ul style="list-style-type: none"> • 1x Telescopic Axis Double complete 		VRKP2YYYYY00007 VRKP4YYYYY00007 VRKP5YYYYY00007 VRKP6YYYYY00007 VRKP6YYYYY00E07	VRKP2 VRKP4 VRKP5 VRKP6 VRKP6.....E00
Plastic upper universal joint with fastener: <ul style="list-style-type: none"> • 1x plastic upper universal joint • 1x clamping screw upper universal joint 		VRKP4YYYYY00008	All Lexium P robots
Plastic lower universal joint with fasteners and indexing bolt: <ul style="list-style-type: none"> • 1x plastic lower universal joint • 6x countersunk screw universal joint • 1x straight pin universal joint 		VRKP4YYYYY00009	All Lexium P robots
Food grade slide films, three sets: <ul style="list-style-type: none"> • 3x food grade slide film 20 • 9x food grade slide film 16 		VRKP4YYYYY00013	All Lexium P robots
Springs, rolls, and fasteners. Set for one robot: <ul style="list-style-type: none"> • 12x springs • 24x roll • 24x screw 		VRKP4YYYYY00023	All Lexium P robots
Gearbox Leakage Protection for the main axis with fasteners: <ul style="list-style-type: none"> • 1x protection box for gearbox • 1x output-flange-extension • 8x screw for output-flange-extension • 4x screw for protection box / gearbox • 12x screw for protection box / housing 		VRKPXYYYYY00031	VRKP2 VRKP4 VRKP5 VRKP6

Item description and content	Representation	Item reference	To be used for
<p>Impact Plate for the main axis with fasteners. Set for one robot:</p> <ul style="list-style-type: none"> • 3x Impact Plate • 12x screw for Impact Plate • 48x sealing washer 		VRKP1YYYYY00035	VRKP0 VRKP1
		VRKPXYYYYY00035	VRKP2 VRKP4 VRKP5 VRKP6
<p>Motor cover extended with fasteners - without sealing:</p> <ul style="list-style-type: none"> • 1x motor cover extended • 4x threaded rod • 4x sealing washer • 4x lock washer 		VRKPXYYYYY00036	VRKP2•••WD VRKP4•••WD VRKP4•••NO VRKP4•••CW VRKP4•••WF VRKP5•••WF VRKP6•••WF for robots with Gearbox Leakage Protection
<p>Lexium P Parallel Plate Bearing Protection:</p> <ul style="list-style-type: none"> • 1x cover top side • 1x flange offset ring • 1x cover bottom side • 6x collar nut • 6x screw for cover bottom side • 9x screw for flange offset ring • 1x straight pin flange offset ring 		VRKPXYYYYY00042	VRKP•••R
<p>Lexium P Double Rotational Module:</p> <ul style="list-style-type: none"> • 1x Double Rotational Module 		VRKPXYYYYY00038	All Lexium P robots
<p>Lexium P Rotational Tilting Module:</p> <ul style="list-style-type: none"> • 1x Rotational Tilting Module 		VRKPXYYYYY00039	All Lexium P robots
<p>Lexium P Rotational Tilting Module HD:</p> <ul style="list-style-type: none"> • 1x Rotational Tilting Module HD 		VRKPXYYYYY00041	All Lexium P robots
<p>Lexium P Rotational Module B:</p> <ul style="list-style-type: none"> • 1x Rotational Module B 		VRKPXYYYYY00045	All Lexium P robots
<p>Lexium P Rotational Module HT-B:</p> <ul style="list-style-type: none"> • 1x Rotational Module HT-B 		VRKPXYYYYY00046	All Lexium P robots

Item description and content	Representation	Item reference	To be used for
Lexium P Double Rotational Module HD: <ul style="list-style-type: none"> 1x Double Rotational Module HD 		VRKPXXXXXX00049	All Lexium P robots
Lexium P Rotational Tilting Module HD-B: <ul style="list-style-type: none"> 1x Rotational Tilting Module HD-B 		VRKPXXXXXX00050	All Lexium P robots
Lexium P Tilting Module HT-B-HD: <ul style="list-style-type: none"> 1x Tilting Module HT-B-HD 		VRKPXXXXXX00052	All Lexium P robots
Lexium P Tilting Module B: <ul style="list-style-type: none"> 1x Tilting Module B 		VRKPXXXXXX00053	All Lexium P robots
Encoder extension cable for the optional modules: <ul style="list-style-type: none"> 1x encoder extension cable 		VW3E2100R030	VRKP0 VRKP1 VRKP2 VRKP4
		VW3E2100R043	VRKP5 VRKP6
Power extension cable for the optional modules: <ul style="list-style-type: none"> 1x power extension cable 		VW3E1168R030	VRKP0 VRKP1 VRKP2 VRKP4
		VW3E1168R043	VRKP5 VRKP6

Troubleshooting

What's in This Chapter

Troubleshooting 248

Troubleshooting

Overview

Malfunction	Probable cause	Solution
Trouble with components.	End of component life cycle.	Note the maintenance plan, page 196.
Squeaking.	Ball sockets are contaminated.	Clean the ball sockets dry, page 200.
	Ball sockets are worn out.	Replace the ball sockets, page 215.
	Spring roll is worn out.	Replace the spring roll, page 216.
Rattling noise.	A spring is absent and/or damaged. NOTE: Verify the upper arm regarding mechanical attachment.	Replace the springs, page 215.
Oil beads up at new gearbox.	Initial oozing of new gearboxes.	Clean the gearbox dry, page 200.
Grease at new ball bearing.	Initial oozing of new bearings.	Clean the ball bearing dry, page 200.
Extensive position deviation after motor replacement.	The robot is not calibrated.	Calibrate the robot, page 228.
	Incorrect motor replacement.	Mount the motor correctly, page 220.

Appendices

What's in This Part

Further Information About the Manufacturer	250
Disposal	251
Declaration of Incorporation	252

Further Information About the Manufacturer

What's in This Chapter

Contact Addresses	250
Product Training Courses.....	250

Contact Addresses

Schneider Electric Automation GmbH

Schneiderplatz 1
97828 Marktheidenfeld, Germany
Phone: +49 9391 603 5000
Fax: +49 89 1250 460 3330
Internet: www.se.com

Other Contacts

See the homepage for additional contact addresses:
[Contact Center | Schneider Electric Global \(se.com\)](#)

Product Training Courses

Product Training Courses

Schneider Electric offers a number of product training courses.

The Schneider Electric training instructors will help you take advantage of the extensive possibilities offered by the system.

See the website (www.se.com) for further information and the seminar schedule.

Disposal

What's in This Chapter

Disposal 251

Disposal

Information on the Disposal of Schneider Electric Products

The robot is delivered on a recyclable ISO plastic pallet. Further packaging comprises cartons and films.

NOTE: The components consist of different materials, which can be reused and must be disposed of separately. Do not return the packaging to the manufacturer.

Dispose of the packaging in accordance with the relevant local, regional or national regulations.

Dispose of the packaging at the disposal sites provided for this purpose.

Dispose of robot in accordance with the applicable local, regional or national regulations.

NOTE: The gearbox units contain lubricants whose disposal may be subject to local, regional, or national regulations apart from the packaging.

Declaration of Incorporation

What's in This Chapter

Declaration of Incorporation 253

Declaration of Incorporation

Overview

Declaration of Incorporation

According to EC directive 2006/42/EC on machinery (Annex II B)
Document number / Month.Year: RBA20130824.09 / 11.2021
- Original Language -



We: Schneider Electric Automation GmbH
Subsidiary of Schneider Electric SE (FR 92500 Rueil-Malmaison)
 Schneiderplatz 1
 97828 Marktheidenfeld
 Germany

Hereby declare that this declaration of conformity is issued under our sole responsibility as manufacturer and that the product(s):

Trademark:	Schneider Electric 
Product, Type, Function:	Lexium P Robot
Models:	VRKP – Series, see detailed list of references
Serial Number:	YYZXXXXXXXX <small>(YY: Year+10, e.g. 25 = 2015; Z: Plant Code; XXXXXXX = cont. number)</small>

with the following references

Reference	Description
VRKP0S****00***	P0 with SH3 motor
VRKP0S****02***	P0 with SH3 Motor
VRKP1S****00***	P1 with SH3 motor
VRKP1S****02***	P1 with SH3 Motor
VRKP2S****00***	P2 with SH3 motor
VRKP2I****00***	P2 with iSH motor
VRKP2L****00***	P2 with ILM motor
VRKP2WM***00***	P2 without motors
VRKP4S****00***	P4 with SH3 motor
VRKP4S****02***	P4 with SH3 motor
VRKP4I****00***	P4 with iSH motor
VRKP4L****00***	P4 with ILM motor
VRKP4WM***00***	P4 without motors
VRKP5S****00***	P5 with SH3 motor
VRKP5S****02***	P5 with SH3 motor
VRKP5L****00***	P5 with ILM motor
VRKP5WM***00***	P5 without motors
VRKP6S****00***	P6 with SH3 motor
VRKP6S****02***	P6 with SH3 motor
VRKP6L****00***	P6 with ILM motor
VRKP6WM***00***	P6 without motors

* are any letters or numbers not affecting the conformity of the product

Declaration of Incorporation

According to EC directive 2006/42/EC on machinery (Annex II B)

Document number / Month.Year: RBA20130824.09 / 11.2021

- Original Language -



is complying with all essential requirements of the Machinery Directive 2006/42/EC, as far as the scope of delivery allows. Additional we declare that the relevant technical documentation is compiled in accordance with part B of Annex VII.

Directive	Fulfilled Requirements	Harmonized Standard
DIRECTIVE 2006/42/EC OF THE EUROPEAN PARLIAMENT AND OF THE COUNCIL of 17 May 2006 on machinery, and amending Directive 95/16/EC	1.1.2, 1.1.3, 1.1.5, 1.3.2, 1.3.4, 1.7.2	EN ISO 10218-1:2011 Robots and robotic devices - Safety requirements for industrial robots - Part 1: Robots

We commit to transmit, in response to a reasoned request by the market surveillance authorities, relevant documents on the partly completed machinery by our documentation department. The method of transmission shall be electronic.

Name and address of the person authorised to compile the technical documentation:

Bernhard Kreidler, Schneider Electric Automation GmbH, Breslauer Straße 7, 77933 Lahr/Schwarzwald – Germany

The partly completed machinery must not be put into service until the final machinery into which it is to be incorporated has been declared in conformity with the provisions of Directive 2006/42/EC on Machinery, where appropriate, and until the EC Declaration of Conformity according to Annex II A is issued.

Schneider Electric Automation GmbH
Schneiderplatz 1
97828 Marktheidenfeld
Telefon: 09391 606-0

Issued at: Marktheidenfeld - Germany, 29th November 2021

i.A. Michael Schweizer
Machine Solutions - Manager Product Compliance

Index

A

ambient conditions 30
attachments 19

B

ball pins
 maintenance 199
 replacement 226
ball sockets
 cleaning 201
 maintenance 198
 replacement 215
bearings
 cleaning 201
brake release 15
brake voltage 138

C

cabling 110
calibration 228
 main axes 229
 robot mechanics 228
 verification 128
capture bolts 126
checking the installation 128, 137
cleaning 200
climatic classes 30
closing bridge 208
collisions
 repair 202
commissioning 138
conditions
 installation 14
 operation 30
 storage 30, 104
 transport 30, 104
connection power 79
contact addresses 250
coordinate system
 verification 137
cycle times 81

D

detail drawings 31
dimensional drawing 59
 main body 62, 64, 66, 69, 72
dimensional drawings 31, 59
direction of rotation
 verification 130
disposal 251
domestic appliances 13
Double Rotational Module 173
 cabling 177
 mounting 177
 payload 179, 188
 product overview 173
 technical data 174
 type plate 173

E

electrical connections 79
electrical data 31
electrical installation 110
emergency stop switch 15
emissions 19
encoder connections 79
environment
 radioactive 13
 saline 13

F

fan 122
fan connections 80
fans
 maintenance 200
 replacement 227
floating systems 13
forbidden environments 13
frame 91

G

gearbox
 cleaning 201
 maintenance 200
 replacement on main axis 220
 replacement on rotational axis 211
 technical data 102
Gearbox Leakage Protection 146
 mounting 147
 replacement 227
ripper 140, 151
grounding 110

H

hazardous, explosive atmospheres 13
hazards 14
help 248
homepage 250
hot surfaces 17

I

incompatible environments 13
index pin 131
inspection after collisions 202
installation 12
 conditions 14
 electrical 110
 general information 107
 verification 128, 137
interference contours 92

L

leakiness 19
life support systems 13
load capacity diagram 89
lower arms
 mounting 133
 replacement 214
lubrication
 leakiness 19

M	
maintenance	195
ball pins	199
ball sockets	198
fans	200
gearbox	200
general information	195
motor	200
rolls on spring pack of lower arm	198
slide films	198
springs	197
telescopic axis	197
universal joints	199
maintenance plan	196
manual movement	20
mechanical data	31
misuse	13
mobile systems	13
modifications	19
module	137
monitoring	138
motor	
maintenance	200
replacement on main axis	220
replacement on telescopic axis	211
technical data	102
motor cover seal	126
motor covers	126
motor direction	
verification	128
motor direction of rotation	
verification	130
motorized	137
mounting	137
Gearbox Leakage Protection	147
general information	107
Parallel Plate Ball Bearing Protection	149
payload	140
Telescopic Axis Double	155
moving without drive energy	20
N	
noise protection	18
O	
operating conditions	14, 30
original equipment	13
P	
parallel plate	
replacement	217
Parallel Plate Ball Bearing Protection	148
mounting	149
parametrization	128
partly completed machinery	12
payload	
mounting	140
performance	90
performance data	81
plain bearings	
replacement	206
portable systems	13
problems and solutions	248
product overview	23
proper use	12
protective devices	138
protective measures	12
Q	
qualification of personnel	14
qualified person	14
R	
radioactive environment	13
remaining risks	14
repair	195
repair after collisions	202
replacement	203
ball pins	226
ball sockets	215
fans	227
Gearbox Leakage Protection	227
gearbox on main axis	220
gearbox on rotational axis	211
lower arms	214
motor on main axis	220
motor on rotational axis	211
parallel plate	217
plain bearings	206
rolls on lower arms	216
slide films	208
springs	215
telescopic axis	204
universal joints	205
upper arms	218
residual risks	14
robot	
cabling	110
grounding	110
rolls	
maintenance	198
replacement	216
rotational axis	131
Rotational Module	157
Rotational Tilting Module	184
cabling	177, 188
mounting	188
payload	179, 188
product overview	157, 184–185
technical data	185
run-on path	94
S	
saline environment	13
SchneiderElectricRobotic library	128
seminars	250
service addresses	250
servicing	196
set pin	132, 156
slide bridge	208
slide films	
maintenance	198
replacement	208
software limits	138
solutions	248
springs	
maintenance	197
replacement	215
start-up	138

stop function categories	95
stopping path	94
stopping time	94
storage conditions	30, 104
strain relief	110
system architecture	22
systems	
floating	13
life support	13
mobile	13
portable	13

T

technical data	
robot	31
telescopic axis	131
maintenance	197
Telescopic Axis Double	153
detail drawing	153
mounting	155
third-party devices	13
Tilting Module	165
cabling	168
calibration	234
maximum torque	167
mounting	168
payload	168
technical data	166
Tilting Module B	
flange dimensions	170
Tilting Module HT-B-HD	
flange dimensions	172
Tilting Modules	
type plate	166
tool center point	91
training	14
training courses	250
transport conditions	30, 104
troubleshooting	248

U

underground	13
universal joints	
cleaning	201
maintenance	199
replacement	205
upper arms	
replacement	218

V

verification	
calibration	128
coordinate system	137
installation	128, 137
motor direction	128
motor direction of rotation	130

W

wiring	110
--------------	-----

Schneider Electric
35 rue Joseph Monier
92500 Rueil Malmaison
France

+ 33 (0) 1 41 29 70 00

www.se.com

As standards, specifications, and design change from time to time,
please ask for confirmation of the information given in this publication.

© 2021 – Schneider Electric. All rights reserved.

EIO0000002173.13