

TeSys[®] ULULC15 Advantys STB Communication Module

User's Manual

03/2009



Schneider Electric assumes no responsibility for any errors that may appear in this document. If you have any suggestions for improvements or amendments or have found errors in this publication, please notify us.

No part of this document may be reproduced in any form or by any means, electronic or mechanical, including photocopying, without express written permission of Schneider Electric.

All pertinent state, regional, and local safety regulations must be observed when installing and using this product. For reasons of safety and to help ensure compliance with documented system data, only the manufacturer should perform repairs to components.

When devices are used for applications with technical safety requirements, the relevant instructions must be followed.

Failure to use Schneider Electric software or approved software with our hardware products may result in injury, harm, or improper operating results.

Failure to observe this information can result in injury or equipment damage.

© 2009 Schneider Electric. All rights reserved.

Table of Contents

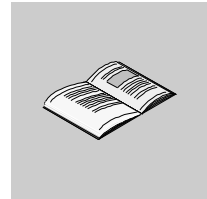

	Safety Information	5
	About the Book	7
Part I	Hardware Implementation	9
Chapter 1	Installation of TeSys U Advantys STB Module (LULC15)	11
	Safety Instructions	12
	Presentation of LULC15 Advantys STB Communication Module	13
	Description and Installation of the Module	15
	Electrical Connection	20
	Architecture and Connections	24
	Island Limitations	26
Chapter 2	Technical Characteristics	29
	Service Conditions and Technical Characteristics	29
Part II	Software Implementation	31
Chapter 3	Communication Module Setup with Advantys STB Configuration Software	33
	Communication Module Setup with Advantys STB Configuration Software	34
	Customizing your Configuration	38
	NIM - LULC15 Communication Data	43
	TeSys U LULC15 Process Images	44
	Using PKW Objects	58
	Overview of the Main Registers for Simplified Management	60
Chapter 4	Managing Faults and Warnings	61
	Displaying Faults	62
	Application Faults	63
	Internal Faults	65
	Warnings - Loss of Communication	66
Chapter 5	Configuration of Reflex Stop Functions	67
	Description of Reflex Stop Functions	68
	Use of Reflex 1 and Reflex 2	70
Index	71

Safety Information

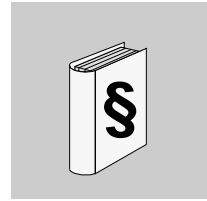

Important Information

NOTICE

Read these instructions carefully, and look at the equipment to become familiar with the device before trying to install, operate, or maintain it. The following special messages may appear throughout this documentation or on the equipment to warn of potential hazards or to call attention to information that clarifies or simplifies a procedure.



The addition of this symbol to a Danger or Warning safety label indicates that an electrical hazard exists, which will result in personal injury if the instructions are not followed.



This is the safety alert symbol. It is used to alert you to potential personal injury hazards. Obey all safety messages that follow this symbol to avoid possible injury or death.

DANGER

DANGER indicates an imminently hazardous situation which, if not avoided, **will result in** death or serious injury.

WARNING

WARNING indicates a potentially hazardous situation which, if not avoided, **can result in** death or serious injury.

CAUTION

CAUTION indicates a potentially hazardous situation which, if not avoided, **can result in** minor or moderate injury.

CAUTION

CAUTION, used without the safety alert symbol, indicates a potentially hazardous situation which, if not avoided, **can result in** equipment damage.

PLEASE NOTE

Electrical equipment should be installed, operated, serviced, and maintained only by qualified personnel. No responsibility is assumed by Schneider Electric for any consequences arising out of the use of this material.

About the Book

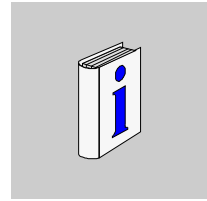

At a Glance

Document Scope

This manual describes the implementation, functionalities and operation of the TeSys U Advantys STB communication module (LULC15).

Field of application: mainly automation systems in industry and building areas.

Validity Note

This manual is valid for LULC15 V1.3 and later versions.

Related Documents

Title of Documentation	Reference Number
LULC15 Advantys STB Module - Instruction Sheet	1639546
TeSys U Communication Variables - User's Manual	1744082
LU•B/LU•S• TeSys U Starters - Instruction Sheet	1629984
LUTM• TeSys U Controller - User's Manual	1743233
LUTM• TeSys U Controller - Instruction Sheet	1743236
LUCM/LUCMT Multifunction Control Units - User's Manual	1743237
LUCM/LUCMT/LUCBT/LUCDT Control Units - Instruction Sheet	AAV40504
LUCA/LUCB/LUCC/LUCD Control Units - Instruction Sheet	AAV40503
Electromagnetic Compatibility - Practical Installation Guidelines	DEG999
Advantys STB System Planning & Installation Guide	890 USE 171 00
Advantys STB Hardware Components Guide (vol 1 and 2)	890 USE 172 00
Advantys STB Profibus DP Network Interface Guide	890 USE 173 00
Advantys STB INTERBUS Network Interface Guide	890 USE 174 00
Advantys STB DeviceNet Network Interface Guide	890 USE 175 00
Advantys STB CANopen Network Interface Guide	890 USE 176 00
Advantys STB Ethernet Network Interface Guide	890 USE 177 00
Advantys STB Modbus Plus Network Interface Guide	890 USE 178 00
Advantys STB Fipio Network Interface Guide	890 USE 179 00
Advantys STB Configuration Software Quick Start Guide	890 USE 180 00

You can download these technical publications and other technical information from our website at www.schneider-electric.com.

User Comments

We welcome your comments about this document. You can reach us by e-mail at techcomm@schneider-electric.com.

Hardware Implementation

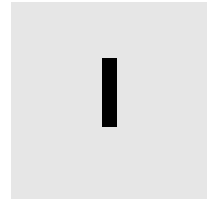

Overview

This part describes the installation and technical characteristics of a TeSys U Advantys STB communication module (LULC15).

What's in this Part?

This part contains the following chapters:

Chapter	Chapter Name	Page
1	Installation of TeSys U Advantys STB Module (LULC15)	11
2	Technical Characteristics	29

Installation of TeSys U Advantys STB Module (LULC15)

1

Overview

This chapter introduces the TeSys U Advantys STB communication module (named LULC15) and describes the different physical installation steps of the product. There are 7 possible configurations, that will be described in this chapter.

What's in this Chapter?

This chapter contains the following topics:

Topic	Page
Safety Instructions	12
Presentation of LULC15 Advantys STB Communication Module	13
Description and Installation of the Module	15
Electrical Connection	20
Architecture and Connections	24
Island Limitations	26

Safety Instructions

General Instructions

CAUTION

HAZARDOUS OPERATION

These devices must be installed, configured and used by qualified staff only.

You must follow all current instructions, standards and regulations.

Check the function settings before starting the motor.

Do not downgrade or modify these devices.

Failure to follow these instructions can result in injury or equipment damage.

CAUTION

IMPROPER COMMUNICATION PORT USAGE

Only use the serial link for transmitting data that is not critical to the application.

There is some delay in the transmission of data relating to motor starter states and load current values. This data must not therefore be used in the actual processing of safety devices and emergency stops.

Data such as Forward and Reverse operation and Stop must not be used in the safety and emergency stop circuits.

Failure to follow these instructions can result in injury or equipment damage.

Presentation of LULC15 Advantys STB Communication Module

Receiving the Product

On opening the box containing the LULC15 Advantys STB communication module, you should find the following items:

- An Instruction Sheet (IS), providing brief pictorial information on the standard installation of the module.
- A LULC15 Advantys STB communication module equipped with connectors.

NOTE: Check that you actually have all the items described above. Make sure that the Instruction Sheet is included, along with the correctly installed connectors.

Functions Offered

The communication module allows you to control remotely, via the Advantys STB, the following bases:

TeSys U starter-controller	LUB** / LU2B**
TeSys U starter	LUS** / LU2S**
TeSys U controller	LUTM**

With the communication module, you can:

- Read the motor starter states,
- Control the motor starter (reversing or non-reversing),
- Adjust the protection functions,
- Read the data processed in the advanced and multifunction control units,
- Read the state of the I/O (controller base).

The TeSys U motor starter can be connected as a preferred device to the End Of Segment module (STB XBE 1100) of an Advantys STB island, with the benefit of getting all the services implemented by Advantys, especially auto-addressing, autobaud, fallback setting, and full software support. TeSys U will be seen as a preferred STB module and will use STB means as a gateway to any upstream fieldbus or communication network.

DANGER

IMPROPER CONTROL VOLTAGE

Use 24VDC from the End of Segment (EOS) module to power the LULC15 communication module. Do not connect voltage in excess of 24VDC.

Failure to follow these instructions will result in death or serious injury.

Data Available with the 7 TeSys U Variants

The available protection and control data depend on the control unit with which the LULC15 Advantys STB communication module is used.

There are 3 types of control units:

- Standard (referenced as LUCA)
- Advanced (referenced as LUCB/C/D, LUCBT/DT)
- Multifunction (referenced as LUCM, LUCMT)

The LULC15 is presented as 7 variants of TeSys U in the Advantys STB environment.

	Short Name	Description
1	TeSys U Sc St - V1.xx	LU•B•/LU•S• + LUCA: TeSys U starter-controller, direct or reverser, with a standard control unit
2	TeSys U Sc Ad - V1.xx	LU•B•/LU•S• + LUCB/C/D: TeSys U starter-controller, direct or reverser, with an advanced control unit
3	TeSys U Sc Mu R - V1.xx	LU•B•/LU•S• + LUCM Remote: TeSys U starter-controller, direct or reverser, with a multifunction control unit
4	TeSys U Sc Mu L - V1.xx	LU•B•/LU•S• + LUCM Local: TeSys U starter-controller, direct or reverser, with a multifunction control unit
5	TeSys U C Ad - V1.xx	LUTM + LUCBT/LUCDT: TeSys U controller with an advanced control unit
6	TeSys U C Mu R - V1.xx	LUTM + LUCMT Remote: TeSys U controller with a multifunction control unit
7	TeSys U C Mu L - V1.xx	LUTM + LUCMT Local: TeSys U controller with a multifunction control unit

The following table describes the data and controls available in each of the 7 TeSys U configuration variants:

Data - Commands	Variants		
	TeSys U Sc St - V1.xx	TeSys U Sc Ad - V1.xx TeSys U C Ad - V1.xx	TeSys U Sc Mu R/L - V1.xx TeSys U C Mu R/L - V1.xx
Start and stop commands	√	√	√
States (ready, running, fault condition)	√	√	√
Warning		√	√
Automatic reset and remote reset via the bus		√	√
Indication of the motor load		√	√
Differentiation of faults		√	√
Remote parameter setting and viewing of all functions			√
"Statistics" function			√
"Monitoring" function			√

Description and Installation of the Module

Front View of the Module

Connectors and LEDs of the LULC15 Advantys STB communication module are described hereafter:

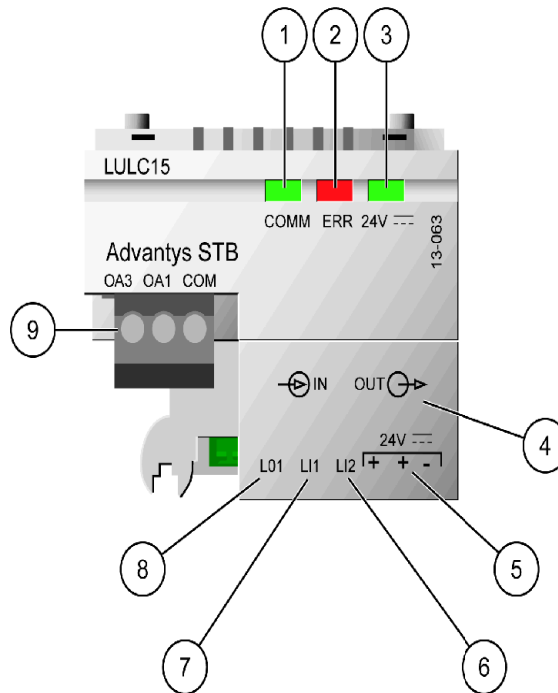

- 1 2-color COMM LED indicating Advantys STB module operational status.
- 2 Red ERR LED indicating Advantys STB module fault.
- 3 Green 24V $\overline{\text{---}}$ LED indicating voltage presence of both internal island power from STB XBE 1100 and 24V $\overline{\text{---}}$ (5).
- 4 Island bus extension cable.
- 5 Connection of the 24V $\overline{\text{---}}$ power supply for outputs OA1, OA3, LO1.
- 6 Logic input 2.
- 7 Logic input 1.
- 8 Logic output 1, assignable depending on configuration reg. 685 (LSB).
- 9 24V $\overline{\text{---}}$ wiring coil connector for the power base:
 - OA1 assignment depends on configuration register 686 (LSB),
 - OA3 assignment depends on configuration register 686 (MSB).

COMM LED Description

Software-controlled **COMM** is a 2-color light-emitting diode (LED), alternating between two states: a Ready state (green color) and an Error state (red color).

COMM LED colors can be flickering, or blinking, or steady, as described hereunder.

2-color COMM LED	Color display mode	Meaning	Action
Off	-	Either the module is not receiving the internal island power from STB XBE 1100, or it has failed.	Check the power.
Flicker Green	The LED repeatedly flickers on for 50ms, then off for 50ms	Auto-addressing is in progress.	Wait for the end of auto-addressing.
Blink Green	The LED repeatedly blinks on for 200ms, then off for 200ms	The module is in a pre-operational mode or is in its fallback state.	No action is required.
Green	Steady	The module has achieved all of the following: - it has power - it has passed the confidence test - it is operational	No action is required. The module is in normal operation.
Flicker Red	The LED repeatedly flickers on for 50ms, then off for 50ms	The 24V  is absent.	Check the power.
Blink Red	The LED blinks on for 200ms, off for 200ms, on again for 200ms, then off for 1s	The island bus is not running.	Check network connections, replace the NIM (network interface module).
Red	Steady	The watchdog timer has timed out.	Cycle the power, restart the communications.
Blink Green+Red	The LED repeatedly blinks green for 200ms, then red for 200ms	A non-fatal field error has been detected.	Cycle the power, restart the communications.

COMM LED Blink Patterns

The following is a representation of the **COMM** LEDs, showing the different colors and flashing rates:

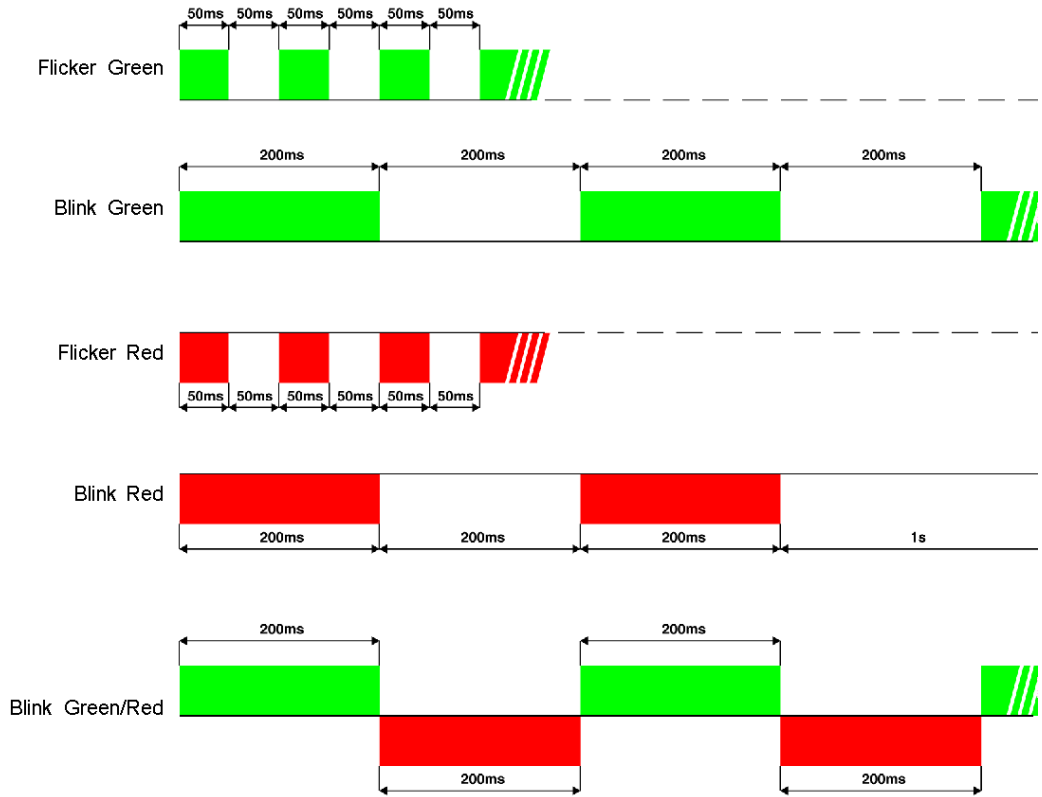

Error (ERR) LED

The red error (**ERR**) LED has 3 different states:

Off	Normal operation
On	Presence of a fault
Blinking	Loss of communication on the Advantys STB network: - between PLC and NIM, or - between Advantys STB bus and LULC15. Fallback strategy is on course. At re-connection, the loss of communication must be acknowledged with Resetwarning bit 703.3. This bit is active on rising edge and must be reset by programming.

24V⁻⁻⁻ LED

The green 24V⁻⁻⁻ LED has 2 different states:

Off	Either internal island power from STB XBE 1100 or 24V ⁻⁻⁻ (that powers outputs OA1, OA3, LO1) is missing.
On	The LULC15 communication module is correctly powered.

Bottom View of the Module

Here is a bottom view of a LULC15 communication module:

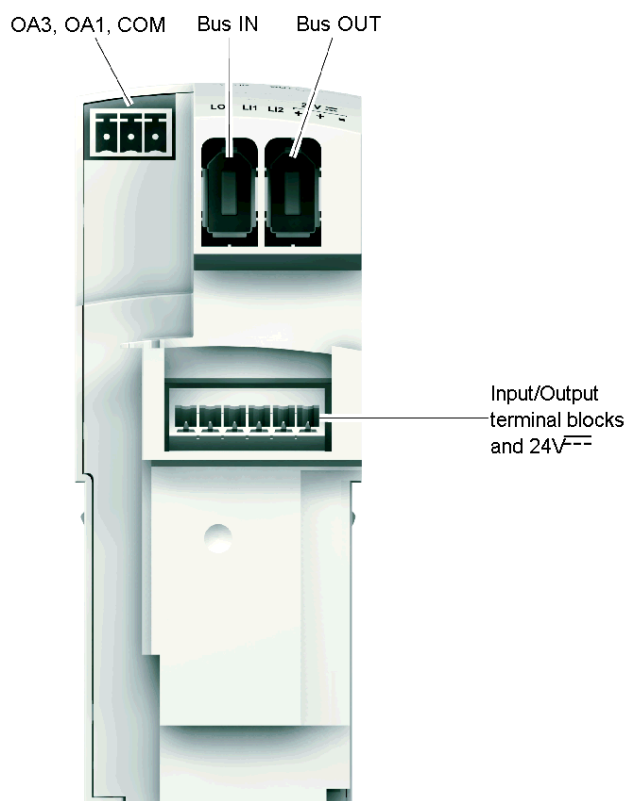

Two island bus extension cable connectors pass the island bus signals (communication signals and address signals) and the internal power distribution for the logic, from one to the other. Both connectors enable daisy-chaining (bus and power distribution for the logic in only one cable).

NOTE: Although identical in shape, IN and OUT buses are not functionally interchangeable. *See Cables and Connections, page 25.*

Communication parameters, including address and baudrate settings, of the LULC15 communication module are automatically defined via the bus connector.

Assembly Order

The LULC15 Advantys STB communication module is installed in a power base or a controller base, beneath the control unit which locks it in position.

To install the module within the power base or the controller base:

Step	Action
1	Choose the prewired coil connection.
2	Insert the LULC15 Advantys STB communication module.
3	Insert the control unit that locks the module.

The illustration below details the steps. Numbers correspond both to the components assembly order and to their positions.

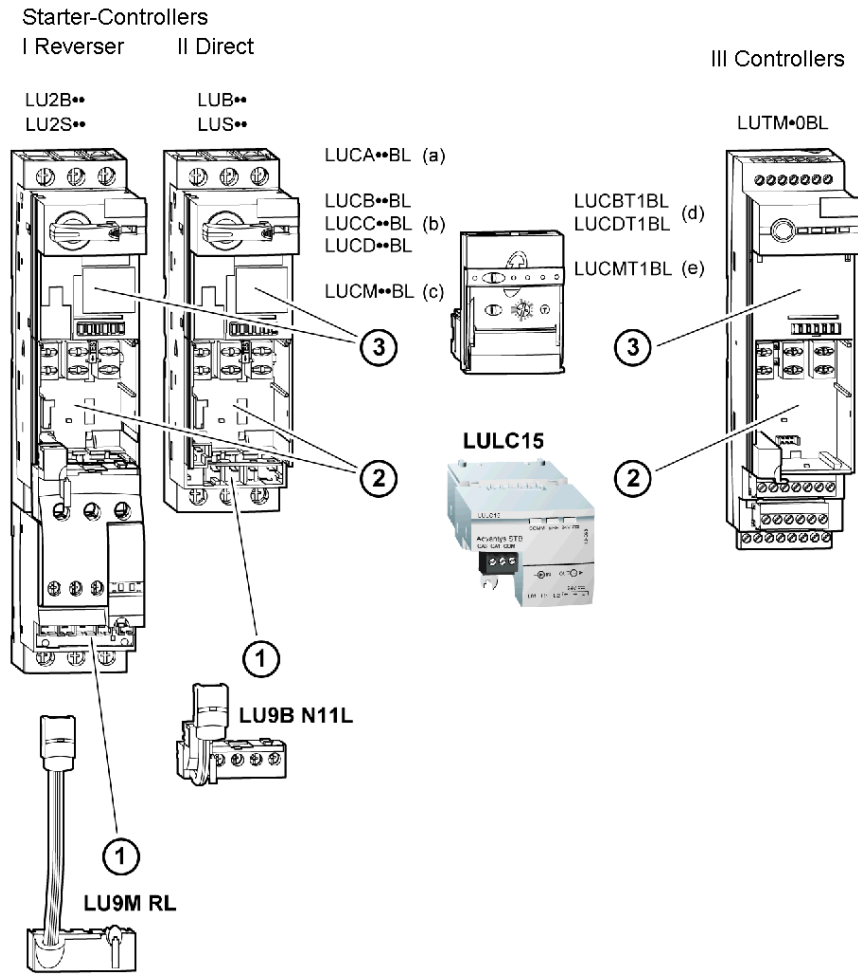

The items associated with each of the 7 TeSys U possible configurations are:

	Short Name	Items	Description
1	TeSys U Sc St - V1.xx	I or II + (a)	Starter or starter-controller, direct or reverser, with a standard control unit
2	TeSys U Sc Ad - V1.xx	I or II + (b)	Starter or starter-controller, direct or reverser, with an advanced control unit
3	TeSys U Sc Mu R - V1.xx	I or II + (c)	Starter or starter-controller, direct or reverser, with a multifunction control unit
4	TeSys U Sc Mu L - V1.xx		
5	TeSys U C Ad - V1.xx	III + (d)	Controller with an advanced control unit
6	TeSys U C Mu R - V1.xx	III + (e)	Controller with a multifunction control unit
7	TeSys U C Mu L - V1.xx		

NOTE: To get details about the 7 variants, refer to *Data Available with the 7 TeSys U Variants, page 14.*

Electrical Connection

24V $\overline{\text{---}}$ and Internal Power Supplies

Schematic of the 24V $\overline{\text{---}}$ (24VDC) and internal power supplies:

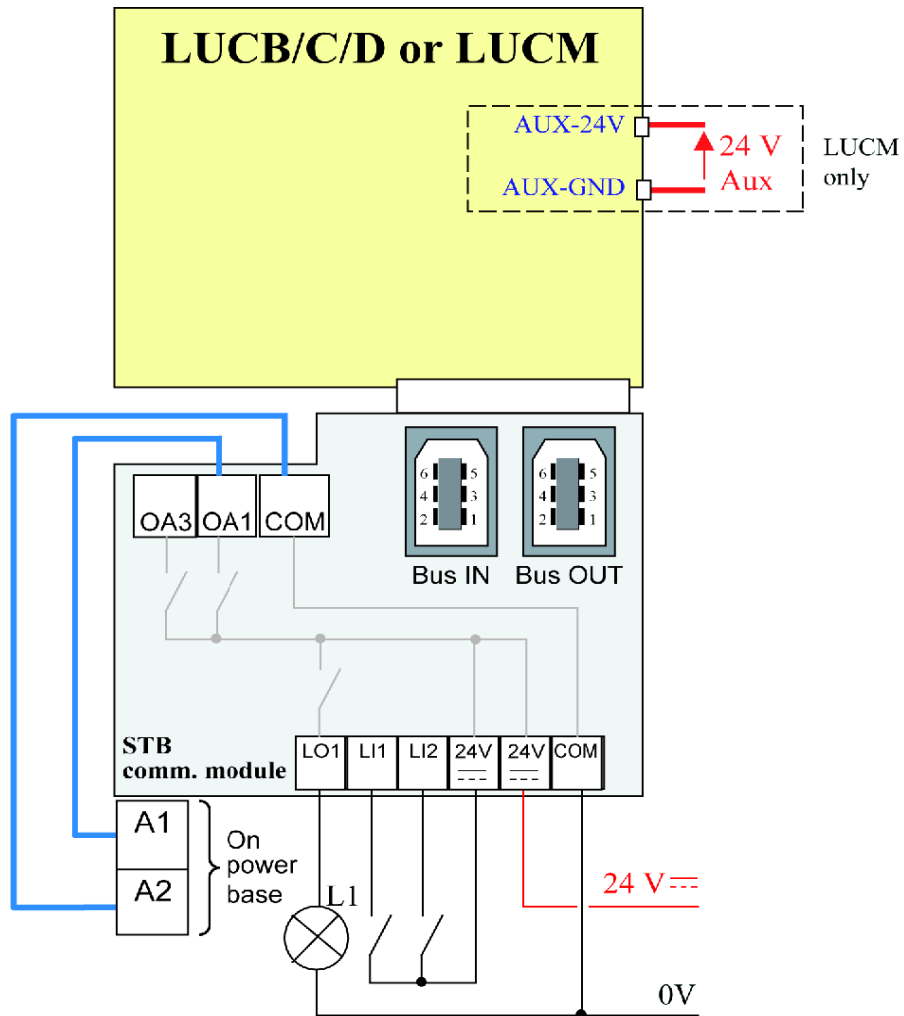

TeSys U Behavior at Power-up with an LUCM/LUCMT

Here is a description of the system behavior at power-up of:

- a power base (LUB/LUS) with an LULC15 communication module and LUCM control unit,
- a controller base (LUTM) with an LULC15 communication module and LUCMT control unit.

LULC15 Internal Power Supply	LUCM 24V Aux	A1/A2 Local Control	Comment
√	√		When LULC15 communication module and LUCM multifunction control unit are powered-up simultaneously (recommended), the system is ready.
√			LULC15 is waiting for LUCM identification. The motor starter is not seen by the Advantys STB island. The ERR LED is on (steady red).
	√ or	√	LUCM is waiting for LULC15, which provokes an M15 fault that must be acknowledged via the LUCM keypad or via the bus, once LULC15 has been powered-up.

LULC15 Internal Power Supply	LUCMT	Comment
√	√	When LULC15 communication module and LUCMT multifunction control unit are powered-up simultaneously (recommended), the system is ready.
√		LULC15 is waiting for LUCMT identification. The motor starter is not seen by the Advantys STB island. The ERR LED is on (steady red).
	√	LUCMT is waiting for LULC15, which provokes an M15 fault that must be acknowledged via the LUCMT keypad, via the bus, or via the LUTM push-button, once LULC15 has been powered-up.

Power Supply for the LULC15 and Outputs OA1, OA3 and LO1

In order to operate, the LULC15 Advantys STB communication module must be powered by a 24V $\overline{\text{---}}$ internal island power from STB XBE 1100.

Power Supply for LUB $\bullet\bullet$ / LUS $\bullet\bullet$ / LU2B $\bullet\bullet$ / LU2S $\bullet\bullet$ Power bases

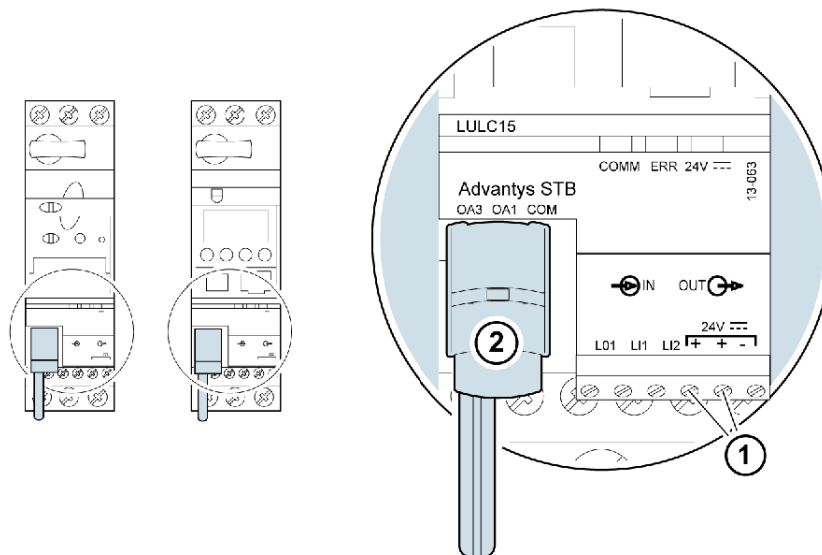

- 1 24 V $\overline{\text{---}}$: power-supply terminal for outputs OA1, OA3 and LO1.
- 2 Prewired link for connecting outputs OA1 and OA3 to terminals A1/A3/A2 on the starter.

Power Supply for LUTM Controller bases

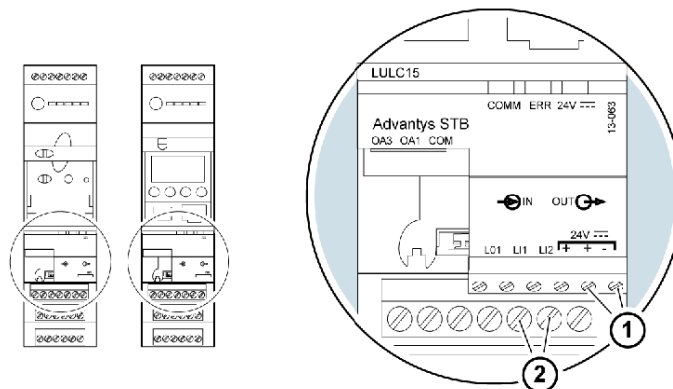

- 1 24 V ==: power-supply terminal for outputs OA1, OA3 and LO1 (if required).
- 2 24 VDC power-supply terminals for LUTM

Power base: Terminal Power Supply

You have 2 options for connecting the power base terminals:

- Power supply via the LULC15 Advantys STB communication module with a prewired link,
- Direct power supply with a wire-to-wire link.

Prewired link

References of the two prewired coils:

Description	with a Power Base	Reference
Prewired Coil Connection	LUB•• / LUS••	LU9B N11L
	LU2B•• / LU2S••	LU9M RL

Illustration for both types of power base:

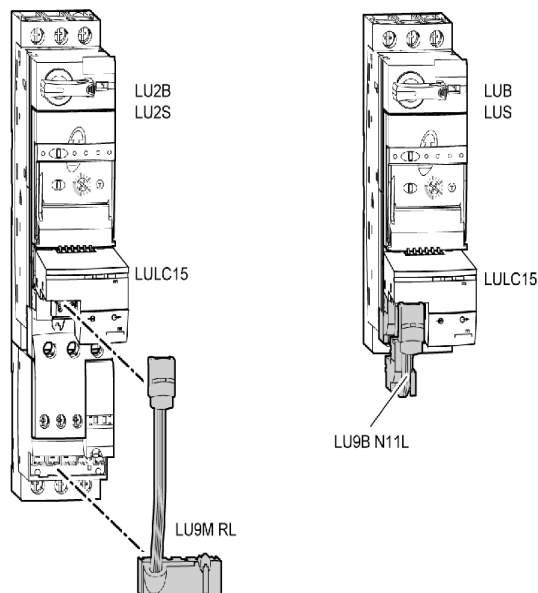

Wire-to-wire link (supplying power to outputs OA1, OA3 and LO1)

This type of link is compulsory in the case of a reversing starter-controller created from a separate **LU6M** reverser block.

The wire-to-wire link is also used to insert, for example, a local control or an external stop control.

LULC15 Conductor Cross-Sections

The following table shows the wire cross-sections that may be used on LULC15 terminals:

Conductor	Wire type	Cross-section (min. to max.)	
1 wire per terminal	<ul style="list-style-type: none"> ● Solid wire ● Stranded wire 	<ul style="list-style-type: none"> ● 0.14 ... 1 mm² ● 0.14 ... 1 mm² 	<ul style="list-style-type: none"> ● AWG 26 ... AWG 18 ● AWG 26 ... AWG 18
	Stranded wire with cable end: <ul style="list-style-type: none"> ● non-insulated ● insulated 	<ul style="list-style-type: none"> ● 0.25 ... 1 mm² ● 0.25 ... 0.5 mm² 	<ul style="list-style-type: none"> ● AWG 24 ... AWG 18 ● AWG 24 ... AWG 20
2 wires (same cross-section) per terminal	<ul style="list-style-type: none"> ● 2 solid wires ● 2 stranded wires 	<ul style="list-style-type: none"> ● 0.14 ... 0.5 mm² ● 0.14 ... 0.75 mm² 	<ul style="list-style-type: none"> ● AWG 26 ... AWG 20 ● AWG 26 ... AWG 20
	2 stranded wires with cable end: <ul style="list-style-type: none"> ● non-insulated ● insulated 	<ul style="list-style-type: none"> ● 0.25 ... 0.34 mm² ● 0.75 mm² 	<ul style="list-style-type: none"> ● AWG 24 ... AWG 22 ● AWG 20

Connectors	3 and 6 pins	
Pitch	3.81 mm	0.15 in.
Tightening torque	0.2 / 0.25 N.m.	1.77/2.213 lb-in.
Flat screwdriver	2.5 mm	0.10 in.

Architecture and Connections

General Architecture

Advantys STB provides TeSys U with additional I/Os and is used as a gateway to any upstream fieldbus or communication network interfaced by Advantys STB.

Here is an example of an architecture:

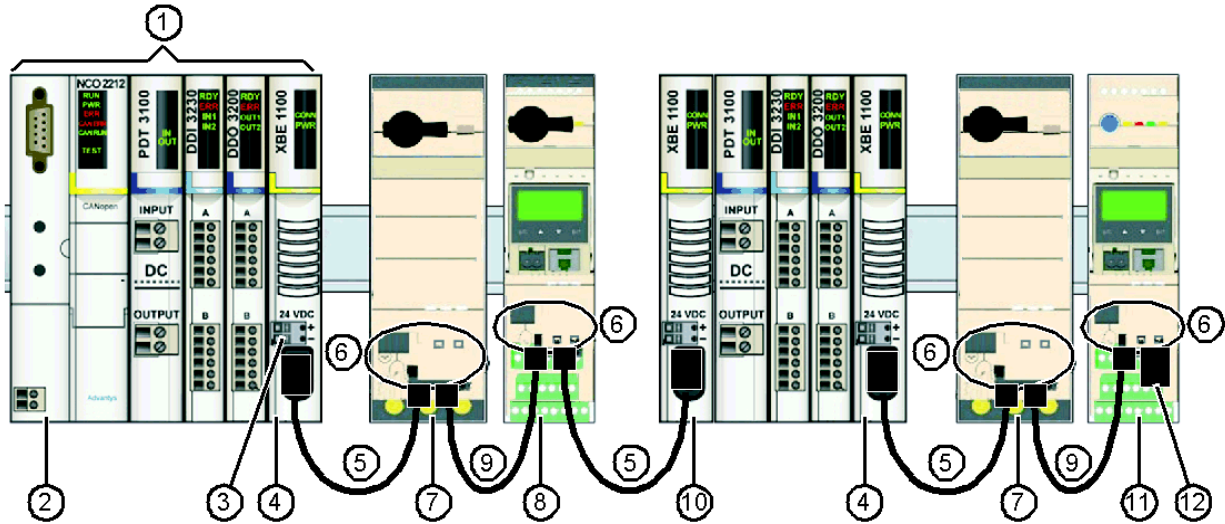

- 1 Advantys STB I/Os
- 2 Network Interface Module (NIM)
- 3 24 VDC power supply for LULC15
- 4 End Of Segment (EOS) STB XBE 1100 used to attach preferred TeSys U modules
- 5 Bend-straight cable with one island bus extension cable connector at each end, providing bus signals and internal power supply (LU9RCD••)
- 6 Advantys STB LULC15 communication modules
- 7 TeSys U Starter-Controller (LUB••) with an advanced control unit (LUCB/C/D)
- 8 TeSys U Starter-Controller (LUB••) with a multifunction control unit (LUCM)
- 9 Bend-straight cable with one island bus extension cable connector at each end, providing bus signals and internal power supply (LU9RDD••)
- 10 Beginning Of Segment (BOS) STB XBE 1300
- 11 TeSys U Controller (LUTM) with a multifunction control unit (LUCMT)
- 12 TeSys U line terminator LU9RFL15

Cables and Connections

Possible island bus extension cables are:

- from an Advantys STB End Of Segment (EOS) to the IN bus of an LULC15 communication module
- from the OUT bus of an LULC15 communication module to an Advantys STB Beginning Of Segment (BOS)

Corresponding cable references are:

Reference	Length
LU9RCD03	0.3m (0.98ft)
LU9RCD10	1.0m (3.28ft)
LU9RCD30	3.0m (9.80ft)
LU9RCD50	5.0m (16.4ft)

- Another possibility is from the OUT bus of an LULC15 communication module to the IN bus of another communication module

Corresponding cable references are:

Reference	Length
LU9RCD03	0.3m (0.98ft)
LU9RCD10	1.0m (3.28ft)
LU9RCD30	3.0m (9.80ft)

Island Limitations

Architecture Example

The example below shows an Advantys STB island architecture including 7 segments:

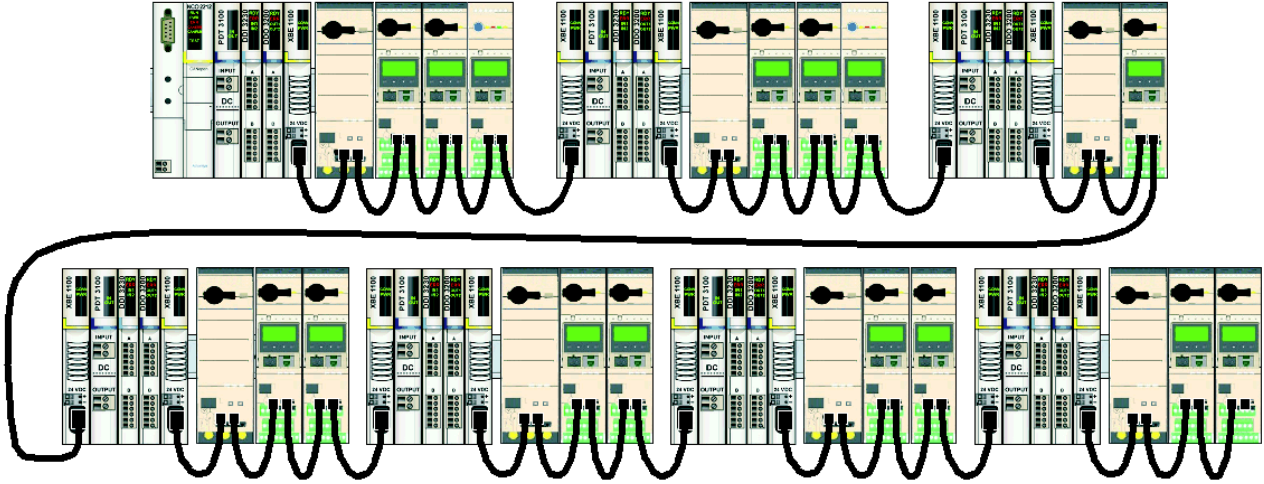

An Advantys STB island architecture has the following limitations:

Maximum number of modules supported by the NIM	Basic NIM: 12 Standard NIM: 31
Number of TeSys U supported by the NIM	Depends on the fieldbus I/O image size limitation: from 1 for Interbus to 32 for Ethernet (See <i>I/O Words Exchanges</i> , page 26.)
Maximum number of segments	Basic NIM: 1 (no extension) Standard NIM: 7
Maximum number of TeSys U on one segment	16 given current consumption (and if fieldbus I/O image size limitation allows it)
Maximum length of the architecture	See Advantys STB System Planning and Installation Guide.

The maximum number of I/O words that can be exchanged through the fieldbus may limit the number of TeSys U supported by the NIM.

I/O Words Exchanges

The table below shows the number of I/O words exchanged by each TeSys U variant:

TeSys U	Input words	Output words
Sc St Starter Controller with Standard Control Unit	6	7
Sc Ad Starter Controller with Advanced Control Unit	7	7
Sc Mu R/L Starter Controller with Advanced Control Unit	8	7
C Ad C Mu R/L Starter Controller with Advanced or Multifunction Control Unit	8	7

Supported TeSys U Associations

The table below shows the maximum number of TeSys U variants supported for each type of NIM:

Fieldbus	Range	NIM limitations	TeSys U Variants			
			Sc St	Sc Ad	Sc Mu	C Ad - C Mu
Ethernet	Standard	32 modules maximum 4096 words In maximum + 4096 words Out maximum	31	31	31	31
CANopen	Standard	32 modules maximum 120 words In maximum +120 words Out maximum	17	17	15	15
Profibus DP	Standard	32 modules maximum 120 words In/Out maximum	9	8	8	8
DeviceNet	Standard	32 modules maximum 128 words In maximum +128 words Out maximum	18	18	16	16
FIPIO	Standard	32 modules maximum 32 words In maximum + 32 words Out maximum	4	4	4	4
Modbus Plus	Standard	32 modules maximum 125 words In maximum +125 words Out maximum	17	17	15	15
Interbus	Standard	32 modules maximum 16 words In maximum +16 words Out maximum	2	2	1	1

TeSys U Mix

The following is an example of Advantys STB island containing different TeSys U variants. The total number of I/O words must be calculated and compared against the NIM capabilities.

TeSys U Variant	Input Words 1 TeSys U	Output Words 1 TeSys U	Number of TeSys U	Total Input Words	Total Output Words
Sc St	6	7	3	18	21
Sc Ad	7	7	5	35	35
Sc Mu R/L	8	7	4	32	28
C Ad	8	7	2	16	14
Sc Mu R/L	8	7	1	8	7
			15	109	105

NOTE: This configuration is only compatible with the following standard NIMs: Ethernet, CANopen, DeviceNet and Modbus Plus.

Technical Characteristics

2

Service Conditions and Technical Characteristics

The LULC15 Advantys STB communication module characteristics include:

- Service conditions
- 24V $\overline{\text{---}}$ and 24V internal power supply circuit characteristics
- Logic outputs (OA1, OA3 and LO1) and logic inputs (LI1 and LI2) characteristics.

Communication characteristics (module port) are also described.

Service Conditions

The LULC15 Advantys STB communication module service conditions are:

Certification	UL, CSA		
Conformity to standards	IEC 62026-1 Overvoltage category III Degree of pollution: 3		
European Community Directives	CE marking. In conformity with the essential requirements of low voltage (LV) equipment and electromagnetic compatibility (EMC) directives.		
Ambient air temperature around the device	Storage	°C	- 40 ... + 85
	Operation	°C	- 25 ... + 55

Product Dimensions

The dimensions of an LULC15 Advantys STB communication module are:

	LULC15
HxLxD	46 x 49 x 113 mm (1.18 x 1.93 x 4.45 in.)
Weight	0.108 kg (0.238 lb.)

For information about dimensions of TeSys U products, see "*Motor starters - open version TeSys U*" *Catalogue*.

24V $\overline{\text{---}}$ Power Supply Circuit

Technical characteristics of 24V $\overline{\text{---}}$ power supply circuit, for a LULC15 Advantys STB communication module, include:

Supply voltage	U_{nominal}	V	24V $\overline{\text{---}}$
	Operating range	V	20 ... 28
Maximum current drawn		A	1.5 at +55 °C
Holdup time		ms	tbd
Protection	against overvoltage		Yes
	against reverse polarity		Yes

24V Internal Power Supply Circuit

Technical characteristics of 24V --- power supply circuit, for a LULC15 Advantys STB communication module, include:

Supply voltage	U _{nominal}	V	24V ---
	Operating range	V	20 ... 28
Maximum current drawn		mA	70
Holdup time		ms	60
Protection	against overvoltage		Yes
	against reverse polarity		- Guaranteed by EOS STB XBE 1100 - Implemented for protection against STB XBE 1000

OA1, OA3 and LO1 Logic Outputs

Output characteristics of an LULC15 Advantys STB communication module include:

Nominal output values	Voltage	V	24V ---
	Current	mA	500
Output limit values	Voltage	V	20 ... 28
	Current	mA	500
Coincidence factor of the 3 outputs		%	100
Output response time (register 704) (Time duration between the request start bit and the change in the output state)		ms	<10 (OA1, OA3, LO1)
Protection	Against short-circuits and overloads		Electronic circuit-breaker with automatic reset
Number of operating cycles	In millions		15
Maximum rate	In operating cycles per hour		3600

LI1 and LI2 Logic Inputs

Input characteristics of an LULC15 Advantys STB communication module include:

Nominal input values	Voltage	V	24V --- (positive logic)	
	Maximum voltage	mA	28V ---	
	Current	mA	7	
Input limit values	State 1	Voltage	V	16
		Current	mA	6
	State 0	Voltage	V	5
		Current	mA	2
Hardware response time	To state 1	ms	10 +/- 30%	
	To state 0	ms	10 +/- 30%	
Input type			Resistive	
Protection	gl fuse	A	1	

Software Implementation



Overview

The hardware implementation of an LULC15 Advantys STB communication module is followed by its software implementation with the Advantys STB configuration software

Software implementation takes place in 3 steps:

1. Selection and implementation of the various STB modules.
(NIM, I/O modules, TeSys U motor starter, etc.) in conformance with application needs. See *Advantys STB System Planning and Installation Guide (890 USE 171)* for more information.
2. Configuration, if necessary, of each individual module.
3. Control and monitoring of the STB modules through the NIM Process images.

What's in this Part?

This part contains the following chapters:

Chapter	Chapter Name	Page
3	Communication Module Setup with Advantys STB Configuration Software	33
4	Managing Faults and Warnings	61
5	Configuration of Reflex Stop Functions	67

Communication Module Setup with Advantys STB Configuration Software

3

Introduction to Advantys STB Configuration Software

A TeSys U motor starter equipped with the LULC15 communication module may be set up via Advantys STB Configuration Software.

It enables you to plan, model, customize and test an island bus design, and download a custom configuration to a physical island. An island is an assembly of distributed I/Os, power distribution, communication and extension modules.

This chapter explains how to logically attach your own TeSys U motor starter.

It provides details on how to set up parameters on the 7 TeSys U variants and how to control and monitor the motor starters through the NIM Process Images.

What's in this Chapter?

This chapter contains the following topics:

Topic	Page
Communication Module Setup with Advantys STB Configuration Software	34
Customizing your Configuration	38
NIM - LULC15 Communication Data	43
TeSys U LULC15 Process Images	44
Using PKW Objects	58
Overview of the Main Registers for Simplified Management	60

Communication Module Setup with Advantys STB Configuration Software

TeSys U Possible Configurations

When in Advantys STB Configuration Software, use the Catalog Browser to associate a TeSys U configuration to an STB island. Within Preferred group, you can choose between 7 different configurations:

TeSys U Sc St - V1.xx
TeSys U Sc Ad - V1.xx
TeSys U Sc Mu R - V1.xx
TeSys U Sc Mu L - V1.xx
TeSys U C Ad - V1.xx
TeSys U C Mu R - V1.xx
TeSys U C Mu L - V1.xx

- The letters **Sc** and **C** stand for **Starter-Controller** and **Controller**, respectively.
- The letters **St**, **Ad** or **Mu** stand for **Standard**, **Advanced** and **Multifunction** control unit, respectively.
- The letters **R** and **L** stand for **Remote** and **Local** configuration.

Selection Criteria of a TeSys U Configuration

Choose TeSys U configuration...	When you need...
TeSys U Sc St - V1.xx	a starter or a starter-controller up to 15kW, for a 3-phase motor class 10, 0-12 or 0-32A rating, with a standard control unit that protects against overloads, short-circuits, phase imbalance, and insulation breaks, and offers a manual reset.
TeSys U Sc Ad - V1.xx	a starter or a starter-controller up to 15kW, for a 3-phase motor class 10 or 20 or a 1-phase motor class 10, 0-12 or 0-32A rating, with an advanced control unit that protects against overloads, short-circuits, phase imbalance, and insulation breaks, and offers a manual or remote/automatic reset.
TeSys U Sc Mu R - V1.xx or TeSys U Sc Mu L - V1.xx	a starter-controller up to 15kW, for a 1 phase or a 3-phase motor class 5-30, 0-12 or 0-32A rating, with a multifunction control unit that protects against overloads and short-circuits, against phase imbalance and insulation breaks, has function warnings, log and monitoring functions, fault differentiation, overtorque and no-load running monitoring, and offers a manual/automatic reset.
TeSys U C Ad - V1.xx	a controller up to 450kW, for a 3-phase motor class 10-20, with an advanced control unit that protects against overloads and short-circuits, against phase imbalance and insulation breaks, and offers a manual or remote/automatic reset.
TeSys U C Mu R - V1.xx or TeSys U C Mu L - V1.xx	a controller up to 450kW, for a 3-phase motor class 5-30, with a multifunction control unit that protects against overloads and short-circuits, against phase imbalance and insulation breaks, has function warnings, log and monitoring functions, fault differentiation, overtorque and no-load running monitoring, and offers a manual/automatic reset.

Local (L) / Remote (R) configuration modes refer to Configuration register 601 (read/write with motor off).

If in a local configuration mode...	It means that 601.7 = 1. This mode preserves the local configuration made with the embedded HMI of the multifunction control unit. It forbids any configuration managed by PLC application through the network, thus preserving your local configuration.
If in a remote configuration mode...	It means that 601.7 = 0. This mode enables the PLC application to remotely configure the TeSys U device. Warning: The parameters overwritten by the PLC application will be lost. This mode is useful in case of faulty device replacement.

By default, the TeSys U device equipped with a multifunction control unit $\geq V3.x$ is in Remote configuration mode.

Example of a TeSys U Configuration

When your TeSys U catalog selection has been configured in an Advantys STB island, you get a graphic representation of your system in the island editor window:

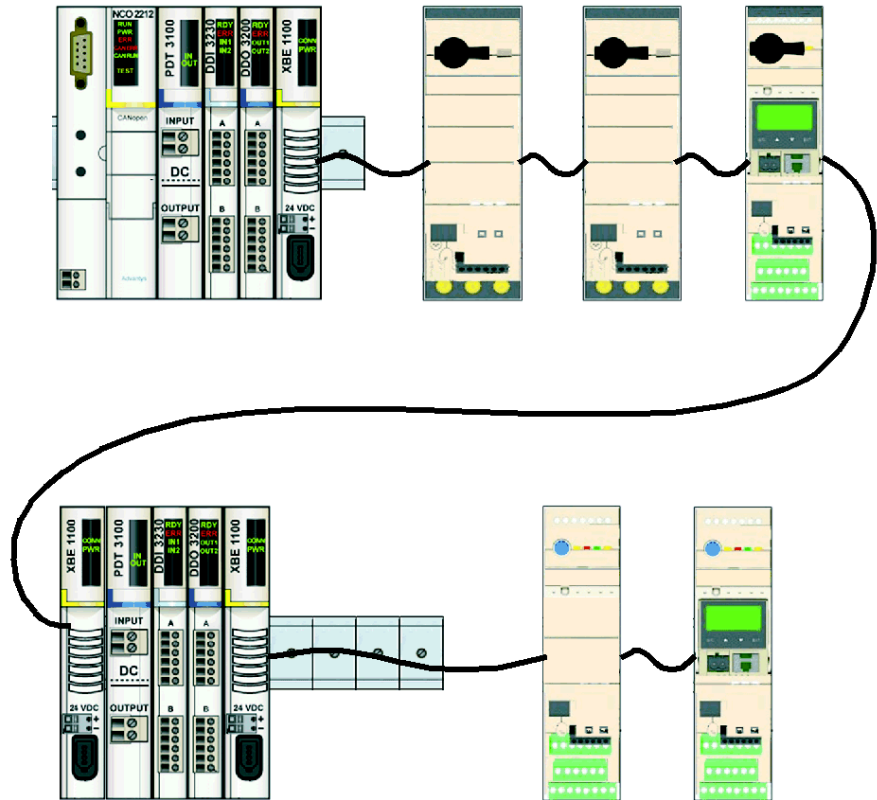

The maximum number of TeSys U configurations attached to an Advantys STB island is defined in *Island Limitations, page 26*. The TeSys U can be placed in any order.

Setting TeSys U Parameters

Depending on the TeSys U variant, parameter settings can be managed through different channels:

	Configuration managed by Advantys software and NIM	Configuration managed through network by PLC application	Configuration locally by embedded HMI of multifunction control unit
TeSys U Sc St V1.xx	Y	Y	
TeSys U Sc Ad V1.xx	Y	Y	
TeSys U Sc Mu R V1.xx		Y	*
TeSys U Sc Mu L V1.xx			Y
TeSys U C Ad V1.xx	Y	Y	
TeSys U C Mu R V1.xx		Y	*
TeSys U C Mu L V1.xx			Y

* The parameters can be set locally by embedded HMI of multifunction control unit on "TeSys U Sc Mu R V1.xx" and "TeSys U C Mu R V1.xx" variants if PLC application doesn't modify any parameters through the network.

TeSys U Parameter Settings with Advantys Software

If you double-click a TeSys U module image in the island editor window, a module editor window opens. Parameter settings with Advantys software is possible on the following 3 TeSys U variants:

- TeSys U Sc St V1.xx
- TeSys U Sc Ad V1.xx
- TeSys U C Ad V1.xx

By default, it opens the Parameters tab:

Data Item Name	Configured Value	User Defined Label
<input type="checkbox"/> Configuration		
● Control Configuration Register (602)	Thermal Fault: Manual Reset	
<input type="checkbox"/> Setting		
● Fallback Strategy (682)	Forced Stop	
● Local/Remote Control (683)	Remote Mode (via the bus)	
<input type="checkbox"/> Inversion of Output Configuration (684)	0	
● Invert Output OA1	0 - Direct	
● Invert Output OA3	0 - Direct	
● Invert Output LO1	0 - Direct	
● Output LO1 Configuration (685)	2	
● Recovery Mode (688)	Disable	
<input type="checkbox"/> Output Configuration		
● OA1 Configuration (686.0-7)	12	
● OA3 Configuration (686.8-15)	13	
● 13 output configuration (687.0-7)	12	
● 23 output configuration (687.8-15)	13	

- **Data item name:** Parameter name. Some parameter entries with +/- sign in front can be expanded and/or collapsed.
- **Value:** Display of parameter values. You can enter them either in a decimal or an hexadecimal format. Default display format is decimal (Hexadecimal box unchecked). Either use pull-down menus or direct keyboard entries.
- **Module help:** Opens on a help window describing parameters.

The following is a list of parameters corresponding to each of the 7 possible TeSys U configurations:

TeSys U Sc St

Parameters for TeSys U Sc St - V1.xx:

Parameter	Description
682	Communication loss fallback strategy
684	Inversion of output configuration
685	Output LO1 configuration
686	Outputs OA1 and OA3 configuration
688	Recovery mode

TeSys U Sc Ad

Parameters for TeSys U Sc Ad - V1.xx:

Parameter	Description
602	Control configuration
682	Communication loss fallback strategy
684	Inversion of output configuration
685	Output LO1 configuration
686	Outputs OA1 and OA3 configuration
688	Recovery mode

TeSys U C Ad**Parameters for TeSys U C Ad - V1.xx:**

Parameter	Description
602	Control configuration
682	Communication loss fallback strategy
683	Controller Local/Remote control mode
684	Inversion of output configuration
685	Output LO1 configuration
686	Outputs OA1 and OA3 configuration
687	Outputs 13 and 23 configuration
688	Recovery mode

Default Settings

Factory default values are:

Parameter	Description	Default Value	Meaning
602.0	Reset mode after thermal overload fault	1	Manual mode
682	Fallback mode of control outputs on communication loss	2	Forced stop Power base: OA1 and OA3 to 0 Controller base: 13 and 23 to 0
683	Controller Local/Remote control mode	0	Control mode = remote (via the bus)
684	Inversion of output configuration	0	Outputs status reflects control bits
685 LSB	Output LO1 configuration	2	LO1 reflects control bit 700.0
686 LSB	Outputs OA1 configuration	12	OA1 reflects control bit 704.0
686 MSB	Outputs OA3 configuration	13	OA3 reflects control bit 704.1
687 LSB	Outputs 13 configuration	12	13 reflects control bit 704.0
687 MSB	Outputs 23 configuration	13	23 reflects control bit 704.1
688	Recovery mode	0	The outputs recover the status they had before power-off

Customizing your Configuration

Introduction

You can either use the default settings or customize your configuration.

Reset Mode After Thermal Overload (Reg 602)

Bits 0, 1 and 2 of register 602 are used to configure the reset mode after thermal overload fault.

Only one of these bit must be set to 1 to select the reset mode.

Reg•	Comment
602.0	If set to 1: Reset is manual (default value).
602.1	If set to 1: Reset is remote by the bus (bit 704.3) or control unit HMI
602.2	If set to 1: Reset is automatic.

Fallback Mode (Reg 682)

Register 682 (read/write access) is used to adjust the fallback mode in case of a communication loss with the PLC.

Register 682 Value	Fallback Mode
0	Ignored
1	Freeze outputs
2	Stop
3	Signal comm loss warning
4	Force run forward
5	Force run reverse

WARNING

AUTOMATIC RESTART OF THE MOTOR

If communication is stopped, the outputs OA1-OA3 take the status corresponding to the selected fallback mode (register 682), but the control bits 704.0 and 704.1 are not modified.

When a loss of communication warning is acknowledged (register 703 or pushbutton on the controller), the motor will automatically restart if the control bits 704.0 or 704.1 were not previously overwritten to zero by the PLC application.

Failure to follow these instructions can result in death, serious injury, or equipment damage.

Description of the different fallback modes:

Fallback Mode	Loss of Communication	Communication Recover	Loss of Communication Acknowledgement
Ignored (reg 682 = 0)	No detection of the loss of communication	No detection of the loss of communication	No acknowledgement of the loss of communication
	OA1 and OA3 keep their status	OA1 and OA3 keep their status	
Freeze outputs (reg 682 = 1)	OA1 and OA3 keep their status	OA1 and OA3 keep their status	On rising edge by bit 703.3 (do not leave set to 1)
	ERR LED blinking on the front face	ERR LED blinking on the front face	Once the acknowledgement is done, the last command stored in register 704 is enabled
		Every new On/Off command is stored but with no impact on OA1 and OA3	ERR LED switches off
Stop (reg 682 = 2)	OA1 and OA3 are forced to 0	OA1 and OA3 are forced to 0	On rising edge by bit 703.3 (do not leave set to 1)
	ERR LED blinking on the front face	ERR LED blinking on the front face	Once the acknowledgement is done, the last command stored in register 704 is enabled
		Every new On/Off command is stored but with no impact on OA1 and OA3	ERR LED switches off
Signal comm loss warning (reg 682 = 3)	OA1 and OA3 keep their status	OA1 and OA3 keep their status	On rising edge by bit 703.3 (do not leave set to 1)
	ERR LED blinking on the front face	ERR LED blinking on the front face	ERR LED switches off
		Every new On/Off command is considered and has an impact on OA1 and OA3	
Force run forward (reg 682 = 4)	OA1 is forced to 1 OA3 is forced to 0	OA1 is forced to 1 OA3 is forced to 0	On rising edge by bit 703.3 (do not leave set to 1)
	ERR LED blinking on the front face	ERR LED blinking on the front face	Once the acknowledgement is done, the last command stored in register 704 is enabled
		Every new On/Off command is stored but with no impact on OA1 and OA3	ERR LED switches off
Force run reverse (reg 682 = 5)	OA1 is forced to 0 OA3 is forced to 1	OA1 is forced to 0 OA3 is forced to 1	On rising edge by bit 703.3 (do not leave set to 1)
	ERR LED blinking on the front face	ERR LED blinking on the front face	Once the acknowledgement is done, the last command stored in register 704 is enabled
		Every new On/Off command is stored but with no impact on OA1 and OA3	ERR LED switches off

NOTE: Red DEL **ERR** flashes to indicate a communication loss (timeout fault).

Control Mode (local/bus) with an LUTM Controller (Reg 683)

Controlling LUTM outputs 13 and 23 depends on the operating mode selected in register 683.

Control Mode	Value		Comment
Remote	0		Outputs 13 and 23 are controlled only by the bus (default value). The state of inputs I.1 and I.2 does not impact outputs 13 and 23.
Local	1		Outputs 13 and 23 are only controlled by inputs I.1 and I.2. Commands via the bus are not taken into account.
Mixed Input	2	If I.10 = 1: Local mode	Outputs 13 and 23 are only controlled by inputs I.1 and I.2.
		If I.10 = 0: Remote mode	Outputs 13 and 23 are only controlled by the bus. The state of inputs I.1 and I.2 does not affect outputs 13 and 23.

Inversion of Outputs Configuration (Reg 684)

Depending on your needs (signalling, run, stop, etc.), you can assign a NO or NC status to outputs OA1, OA3 and LO1, by configuring register 684.

Bit	Value	Comment
648.0	0	No inversion of output OA1 (default value)
		Inversion of output OA1
648.1	1	No inversion of output OA3 (default value)
		Inversion of output OA3
648.2	2	No inversion of output LO1 (default value)
		Inversion of output LO1

Output LO1 Configuration (Reg 685 LSB)

To change the assignment (default setting), select another value (0 to 45), as described in *Assignment of outputs LO1, OA1, OA3, 13 and 23, page 42*.

Assignment/control (default setting) of LULC15 output LO1 is:

Register	Value	Default setting	Comment
685 - 0 to 7	0 to 45	2	Output LO1 = image of register 700.0 (control of output LO1)

To change the assignment, select another value as described in *Assignment of outputs LO1, OA1, OA3, 13 and 23, page 42*.

Output OA1 Configuration (Reg 686 LSB)

Assignment/control (default setting) of LULC15 output OA1 is:

Register	Value	Default setting	Comment
686 - 0 to 7	0 to 45	12	Output OA1 = image of register 704.0 (control of output OA1)

To change the assignment, select another value as described in *Assignment of outputs LO1, OA1, OA3, 13 and 23, page 42*.

Output OA3 Configuration (Reg 686 MSB)

Assignment/control (default setting) of LULC15 output OA3 is:

Register	Value	Default setting	Comment
686 - 8 to 15	0 to 45	13	Output OA3 = image of register 704.1 (control of output OA3)

To change the assignment, select another value as described in *Assignment of outputs LO1, OA1, OA3, 13 and 23, page 42*.

Output 13 Configuration (Reg 687 LSB)

Assignment/control (default setting) of LUTM output 13 is:

Register	Value	Default setting	Comment
687 - 0 to 7	0 to 45	12	Output 13 = image of register 704.0 (control of output 13)

To change the assignment, select another value as described in *Assignment of outputs LO1, OA1, OA3, 13 and 23, page 42*.

Output 23 Configuration (Reg 687 MSB)

Assignment/control (default setting) of LUTM output 23 is:

Register	Value	Default setting	Comment
687 - 8 to 15	0 to 45	13	Output 23 = image of register 704.1 (control of output 23)

To change the assignment, select another value as described in *Assignment of outputs LO1, OA1, OA3, 13 and 23, page 42*.

Recovery Mode After Stopping (Reg 688)

If you use register 704 to control outputs OA1-OA3, writing value 1 to register 688 locks the motor and prevents it from restarting after the occurrence of certain events:

- Loss followed by restoration of 24 VDC (outputs OA1-OA3).
- Change in position of rotary knob on power base followed by return to Ready position.

When one of these events occurs, the control bits 704.0 and 704.1 (outputs OA1-OA3) are forced to 0 automatically. Once these conditions have disappeared, control of the motor can be restored by sending a new run command.

WARNING

AUTOMATIC RESTART OF THE MOTOR

In the case of cyclic writing to register 704 (e.g., an LUFPP gateway in its predefined configuration), this monitoring function must be used with caution. The application program must take this state into account and request that bits 704.0 or 704.1 are written to 0. Otherwise, when this event disappears, the motor will restart automatically.

Failure to follow these instructions can result in death, serious injury, or equipment damage.

Assignment of outputs LO1, OA1, OA3, 13 and 23

Register 685 (for output LO1), register 686 (for outputs OA1 and OA3), and register 687 (for outputs 13 and 23) assign values. An output copies the state of a register bit.

Value	Description of assigned value	Sc St	Sc Ad C Ad
0	The corresponding output is forced to 0 (0V)	√	√
1	The corresponding output is forced to 1 (24V)	√	√
2	State of register 700, bits 0-2: - 700.0 --> LO1 - 700.1 --> OA1 - 700.2 --> OA3	√	√
3	452.3 (Thermal overload fault)		√
4	461.3 (Thermal overload warning)		√
5	457.0 (System ready)	√	√
6	457.1	√	√
7	State of bit 457.2	√	√
8	The corresponding output copies the result of "Reflex stop 1: forward"	√	√
9	The corresponding output copies the result of "Reflex stop 1: reverse"	√	√
10	The corresponding output copies the result of "Reflex stop 2: forward"	√	√
11	The corresponding output copies the result of "Reflex stop 2: reverse"	√	√
12	The corresponding output copies the result of "Forward direction" (default OA1 value)	√	√
13	The corresponding output copies the result of "Reverse direction" (default OA3 value)	√	√
14	452.0 (Short-circuit fault)		√
15	452.1 (Overcurrent fault)		√
16	452.2 (Ground fault)		
17	452.3 (Thermal overload fault)		√
18	452.4 (Long start fault)		
19	452.5 (Mechanical locking (jam) fault)		
20	452.6 (Phase imbalance fault)		
21	452.7 (Underload fault)		
22	452.8 (Shunt trip)		
23	452.9 (Test trip)		
24	452.10 (Communication loss fault on LUCM Modbus port)		
25	452.11 (Control unit internal fault)		√
26	452.12 (Module identification or internal communication fault)		
27	452.13 (Module internal fault)	√	√
28-31	<i>(Reserved)</i>		
32	461.2 (Ground fault warning)		
33	461.3 (Thermal overload warning)		√
34	461.4 (Long start warning)		
35	461.5 (Mechanical locking (jam) warning)		
36	461.6 (Phase imbalance warning)		
37	461.7 (Under-current warning)		
38-39	<i>(Reserved)</i>		
40	461.10 (Communication loss on LUCM Modbus port)		
41	461.11 (Internal temperature warning)		
42	461.12 (Module identification or internal communication warning)		
43-44	<i>(Reserved)</i>		
45	461.15 (Module warning)	√	√

NIM - LULC15 Communication Data

Introduction

Here are general details about output data (from the NIM to the LULC15 communication module), and input data (from the LULC15 communication module to the NIM).

Output Data (from the NIM)

Output data is written to the NIM by the fieldbus master or by an HMI panel connected to the NIM's CFG port.

The NIM keeps a record of output data in the output process image. Each output module on the island bus is represented by 1 data block. Its specific position in the process image is based on the module's physical location on the island bus.

The NIM transparently sends each data block to the associated output module. The LULC15 Communication Module uses 6 contiguous registers in its associated output data block.

The mapping is independent of the control unit type.

Input Data (from LULC15)

The LULC15 communication module sends a representation of the operating state of its input channels to the island's NIM. The NIM stores the information in registers. This information can be read by the fieldbus master or by an HMI panel connected to the NIM's CFG port.

The input data process image is part of a block of registers reserved in the NIM's memory.

The module is represented by contiguous registers in this block. The number of registers depends on the control unit type (standard, advanced or multifunction).

Their positions in the process image are based on the module's physical location on the island bus.

TeSys U LULC15 Process Images

Output and Input Process Image

There are 4 different Process Images for the 7 TeSys U variants:

- TeSys U Sc St - V1.xx
- TeSys U Sc Ad - V1.xx
- TeSys U Sc Mu R - V1.xx and TeSys U Sc Mu L - V1.xx
- TeSys U C Ad - V1.xx, TeSys U C Mu R - V1.xx and TeSys U C Mu L - V1.xx.

The Output Process Image (from NIM to LULC15) is related to the commands.

The Input Process Image (from LULC15 to NIM) is related to the status.

Outputs/Inputs for the different TeSys U variants are described below.

WARNING

AUTOMATIC RESTART OF THE MOTOR

The motor will automatically restart if the control bits 704.0 or 704.1 were not previously overwritten to zero by the PLC application, in case of a cyclic writing to register 704 and on the occurrence of one of the following events:

- Loss followed by restoration of the outputs power supply 24 VDC.
- Change in position of rotary knob on power base followed by return to Ready position.
- Communication break followed by restoration.

Failure to follow these instructions can result in death, serious injury, or equipment damage.

TeSys U Sc St Output Data Map**Starter Controller with Standard Control Unit**

Output Data Map = 7 words		
Word	Register	Description
1	704	Control register
2	703	Control of communication module
3	700	Output control
4	PKW1	PKW request object
5	PKW2	
6	PKW3	PKW request data
7	PKW4	

Word 1	Register 704 - Control register
Bit 0	Run forward
Bit 1	Run reverse
Bit 2	Reserved
Bit 3	Fault reset: if register 451=102 or 104, fault acknowledgment causes a return to communication module factory settings. This bit is active on the rising edge and must be reset to 0 by programming.
Bit 4 to bit 15	Reserved

Word 2	Register 703 - Control of communication module
Bit 0 to bit 12	Reserved
Bit 3	Reset warning: communication loss This bit is active on the rising edge and must be reset to 0 by programming.
Bit 4 to bit 15	Reserved

Word 3	Register 700 - Output control
Bit 0	Control of output LO1 (if Reg 685=2)
Bit 1	Control of output OA1 (if Reg 686 LSB=2)
Bit 2	Control of output OA3 (if Reg 686 MSB=2)
Bit 3 to bit 15	Reserved

Word 4 and 5	PKW Service
	PKW Request object

Word 6 and 7	PKW Service
	PKW Request data

TeSys U Sc St Input Data Map

Starter Controller with Standard Control Unit

Input Data Map = 6 words		
Word	Register	Description
1	455	Status register
2	458	I/O status register
3	PKW1	PKW request object
4	PKW2	
5	PKW3	PKW request data
6	PKW4	

Word 1	Register 455 - Status register
Bit 0	Ready: LUB**/2B** = the rotary handle is turned to 'On' position and there is no fault. LUS**/2S** = the push-button is pressed and there is no fault.
Bit 1	Pole status = closed
Bit 2	All fault
Bit 3	All warning
Bit 4	Tripped: LUB**/2B** = the rotary handle is turned to "Trip" position. LUS**/2S** = the push-button is depressed.
Bit 5 to bit 15	Reserved

Word 2	Register 458 - I/O Status
Bit 0	OA1 status
Bit 1	OA3 status
Bit 2	LO1 status
Bit 3 to bit 7	Reserved
Bit 8	LI1 status
Bit 9	LI2 status
Bit 10 to bit 15	Reserved

Word 3 and 4	PKW Service
	PKW Request object

Word 5 and 6	PKW Service
	PKW Request data

TeSys U Sc Ad Output Data Map**Starter Controller with Advanced Control Unit**

Output Data Map = 7 words		
Word	Register	Description
1	704	Control register
2	703	Control of communication module
3	700	Output control
4	PKW1	PKW request object
5	PKW2	
6	PKW3	PKW request data
7	PKW4	

Word 1	Register 704 - Control register
Bit 0	Run forward
Bit 1	Run reverse
Bit 2	Reserved
Bit 3	Fault reset: if register 451=102 or 104, fault acknowledgment causes a return to communication module factory settings. This bit is active on the rising edge and must be reset to 0 by programming.
Bit 4 to bit 15	Reserved

Word 2	Register 703 - Control of communication module
Bit 0 to bit 12	Reserved
Bit 3	Reset warning: communication loss This bit is active on the rising edge and must be reset to 0 by programming.
Bit 4 to bit 15	Reserved

Word 3	Register 700 - Output control
Bit 0	Control of output LO1 (if Reg 685=2)
Bit 1	Control of output OA1 (if Reg 686 LSB=2)
Bit 2	Control of output OA3 (if Reg 686 MSB=2)
Bit 3 to bit 15	Reserved

Word 4 and 5	PKW Service
	PKW Request object

Word 6 and 7	PKW Service
	PKW Request data

TeSys U Sc Ad Input Data Map

Starter Controller with Advanced Control Unit

Input Data Map = 6 words		
Word	Register	Description
1	455	Status register
2	458	I/O status register
3	461	Warning register
4	PKW1	PKW request object
5	PKW2	
6	PKW3	PKW request data
7	PKW4	

Word 1	Register 455 - Status register
Bit 0	Ready: LUB••/2B•• = the rotary handle is turned to 'On' position and there is no fault. LUS••/2S•• = the push-button is pressed and there is no fault.
Bit 1	Pole status = closed
Bit 2	All fault
Bit 3	All warning
Bit 4	Tripped: LUB••/2B•• = the rotary handle is turned to "Trip" position. LUS••/2S•• = the push-button is depressed.
Bit 5	Fault reset authorized
Bit 6	Reserved
Bit 7	Motor running with detection of current, if greater than 10% FLA
Bit 8 to bit 13	Average motor current in % of FLA. 32 = 100%, 63 = 200%
Bit 14	Reserved
Bit 15	Motor start in progress 1 = ascending current is greater than 10% FLA 0 = descending current is lower than 150% FLA

Word 2	Register 458 - I/O Status
Bit 0	OA1 status
Bit 1	OA3 status
Bit 2	LO1 status
Bit 3 to bit 7	Reserved
Bit 8	LI1 status
Bit 9	LI2 status
Bit 10 to bit 15	Reserved

Word 3	Register 461 - Warning register
Bit 0 to bit 2	Reserved
Bit 3	Thermal warning
Bit 4 to bit 14	Reserved
Bit 15	Module warning

Word 4 and 5	PKW Service
	PKW Request object

Word 6 and 7	PKW Service
	PKW Request data

TeSys U Sc Mu L and TeSys U Sc Mu R Output Data Map**Starter Controller with Multifunction Control Unit Local and Remote**

Output Data Map = 7 words		
Word	Register	Description
1	704	Control register
2	703	Control of communication module
3	700	Output control
4	PKW1	PKW request object
5	PKW2	
6	PKW3	PKW request data
7	PKW4	

Word 1	Register 704 - Control register
Bit 0	Run forward
Bit 1	Run reverse
Bit 2	Reserved
Bit 3	Fault reset: if register 451=102 or 104, fault acknowledgment causes a return to communication module factory settings. This bit is active on the rising edge and must be reset to 0 by programming.
Bit 4	Reserved
Bit 5	Launch automatic thermal overload fault test
Bit 6 to bit 11	Reserved
Bit 12	Reserved
Bit 13 to bit 15	Reserved

Word 2	Register 703 - Control of communication module
Bit 0 to bit 12	Reserved
Bit 3	Reset warning: communication loss This bit is active on the rising edge and must be reset to 0 by programming.
Bit 4 to bit 15	Reserved

Word 3	Register 700 - Output control
Bit 0	Control of output LO1 (if Reg 685=2)
Bit 1	Control of output OA1 (if Reg 686 LSB=2)
Bit 2	Control of output OA3 (if Reg 686 MSB=2)
Bit 3 to bit 15	Reserved

Word 4 and 5	PKW Service
	PKW Request object

Word 6 and 7	PKW Service
	PKW Request data

TeSys U Sc Mu L and TeSys U Sc Mu R Input Data Map

Starter Controller with Multifunction Control Unit Local and Remote

Input Data Map = 8 words		
Word	Register	Description
1	455	Status register
2	458	I/O status register
3	461	Warning register
4	457	Mechanical and power supply status register
5	PKW1	PKW request object
6	PKW2	
7	PKW3	PKW request data
8	PKW4	

Word 1	Register 455 - Status register
Bit 0	Ready: LUB**/2B** = the rotary handle is turned to 'On' position and there is no fault. LUS**/2S** = the push-button is pressed and there is no fault.
Bit 1	Pole status = closed
Bit 2	All fault
Bit 3	All warning
Bit 4	Tripped: LUB**/2B** = the rotary handle is turned to "Trip" position. LUS**/2S** = the push-button is depressed.
Bit 5	Fault reset authorized
Bit 6	A1-A2 terminals powered up
Bit 7	Motor running with detection of current, if greater than 10% FLA
Bit 8 to bit 13	Average motor current in % of FLA. 32 = 100%, 63 = 200%
Bit 14	Reserved
Bit 15	Motor start in progress 1 = ascending current is greater than 10% FLA 0 = descending current is lower than 150% FLA

Word 2	Register 458 - I/O Status
Bit 0	OA1 status
Bit 1	OA3 status
Bit 2	LO1 status
Bit 3 to bit 7	Reserved
Bit 8	LI1 status
Bit 9	LI2 status
Bit 10 to bit 15	Reserved

Word 3	Register 461 - Warning register
Bit 0 to bit 1	Reserved
Bit 2	Ground fault warning
Bit 3	Thermal warning
Bit 4	Long start warning
Bit 5	Jam warning
Bit 6	Phase imbalance warning
Bit 7	Under-current warning
Bit 8 to bit 9	Reserved
Bit 10	Communication port on LUCM Modbus port
Bit 11	Internal temperature warning
Bit 12	Module identification or internal communication warning
Bit 13 to bit 14	Reserved
Bit 15	Module warning

Word 4	Register 457 - Mechanical and power supply status register
Bit 0	Button position "On"
Bit 1	Button position "Trip"
Bit 2	Contactator state "On"
Bit 3	24V DC power supply present on outputs
Bit 4 to bit 15	Reserved

Word 5 and 6	PKW Service
	PKW Request object

Word 7 and 8	PKW Service
	PKW Request data

TeSys U C Ad Output Data MapController with **Advanced Control Unit**

Output Data Map = 7 words		
Word	Register	Description
1	704	Control register
2	703	Control of communication module
3	700	Output control
4	PKW1	PKW request object
5	PKW2	
6	PKW3	PKW request data
7	PKW4	

Word 1	Register 704 - Control register
Bit 0	Run forward
Bit 1	Run reverse
Bit 2	Reserved
Bit 3	Fault reset: if register 451=102 or 104, fault acknowledgment causes a return to communication module factory settings. This bit is active on the rising edge and must be reset to 0 by programming.
Bit 4 to bit 15	Reserved

Word 2	Register 703 - Control of communication module
Bit 0 to bit 12	Reserved
Bit 3	Reset warning: communication loss This bit is active on the rising edge and must be reset to 0 by programming.
Bit 4 to bit 15	Reserved

Word 3	Register 700 - Output control
Bit 0	Control of output LO1 (if Reg 685=2)
Bit 1	Control of output OA1 (if Reg 686 LSB=2)
Bit 2	Control of output OA3 (if Reg 686 MSB=2)
Bit 3	Control of output 13 (if Reg 687 MSB=2)
Bit 4	Control of output 23 (if Reg 687 MSB=2)
Bit 5 to bit 15	Reserved

Word 4 and 5	PKW Service
	PKW Request object

Word 6 and 7	PKW Service
	PKW Request data

TeSys U C Ad Input Data Map**Controller with Advanced Control Unit**

Input Data Map = 8 words		
Word	Register	Description
1	455	Status register
2	458	I/O status register
3	461	Warning register
4	459	I/O status on controller base
5	PKW1	PKW request object
6	PKW2	
7	PKW3	PKW request data
8	PKW4	

Word 1	Register 455 - Status register
Bit 0	Ready: LUB**/2B** = the rotary handle is turned to 'On' position and there is no fault. LUS**/2S** = the push-button is pressed and there is no fault.
Bit 1	Input I.3 or I.4 powered-on
Bit 2	All fault
Bit 3	All warning
Bit 4	Tripped: LUB**/2B** = the rotary handle is turned to "Trip" position. LUS**/2S** = the push-button is depressed.
Bit 5	Fault reset authorized
Bit 6	Input I.1 or I.2 powered-on
Bit 7	Motor running with detection of current, if greater than 10% FLA
Bit 8 to bit 13	Average motor current in % of FLA. 32 = 100%, 63 = 200%
Bit 14	In local control
Bit 15	Motor start in progress 1 = ascending current is greater than 10% FLA 0 = descending current is lower than 150% FLA

Word 2	Register 458 - I/O Status
Bit 0	OA1 status
Bit 1	OA3 status
Bit 2	LO1 status
Bit 3 to bit 7	Reserved
Bit 8	LI1 status
Bit 9	LI2 status
Bit 10 to bit 15	Reserved

Word 3	Register 461 - Warning register
Bit 0 to bit 2	Reserved
Bit 3	Thermal warning
Bit 4 to bit 14	Reserved
Bit 15	Module warning

Word 4	Register 459 - I/O status on controller base
Bit 0	I.1 = local control of output 13
Bit 1	I.2 = local control of output 23
Bit 2	I.3 = contactor status on output 13
Bit 3	I.4 = contactor status on output 23
Bit 4	I.5 = input status (reset)
Bit 5	I.6 = input status (external fault)
Bit 6	I.7 = input status (system ready)
Bit 7	I.8 = input status (free)
Bit 8	I.9 = input status (free)
Bit 9	I.10 = input status in local/remote mixed mode if 683 = 2, otherwise free
Bit 10 to bit 11	Reserved
Bit 12	Output 13 status (1 = OA1 closed)
Bit 13	Output 23 status (1 = OA2 closed)
Bit 14	Output 95-96 and 97-98 status (1 = 95-96 closed and 97-98 opened)
Bit 15	Output 05-06 status (1 = 05-06 closed)

Word 5 and 6	PKW Service
	PKW Request object

Word 7 and 8	PKW Service
	PKW Request data

TeSys U C Mu L and TeSys U C Mu R Output Data MapController with **Multifunction Control Unit Local and Remote**

Output Data Map = 7 words		
Word	Register	Description
1	704	Control register
2	703	Control of communication module
3	700	Output control
4	PKW1	PKW request object
5	PKW2	
6	PKW3	PKW request data
7	PKW4	

Word 1	Register 704 - Control register
Bit 0	Run forward
Bit 1	Run reverse
Bit 2	Reserved
Bit 3	Fault reset: if register 451=102 or 104, fault acknowledgment causes a return to communication module factory settings. This bit is active on the rising edge and must be reset to 0 by programming.
Bit 4	Reserved
Bit 5	Launch automatic thermal overload fault test
Bit 6 to bit 11	Reserved
Bit 12	Reserved
Bit 13 to bit 15	Reserved

Word 2	Register 703 - Control of communication module
Bit 0 to bit 12	Reserved
Bit 3	Reset warning: communication loss This bit is active on the rising edge and must be reset to 0 by programming.
Bit 4 to bit 15	Reserved

Word 3	Register 700 - Output control
Bit 0	Control of output LO1 (if Reg 685=2)
Bit 1	Control of output OA1 (if Reg 686 LSB=2)
Bit 2	Control of output OA3 (if Reg 686 MSB=2)
Bit 3	Control of output 13 (if Reg 687 LSB=2)
Bit 4	Control of output 23 (if Reg 687 MSB=2)
Bit 5 to bit 15	Reserved

Word 4 and 5	PKW Service
	PKW Request object

Word 6 and 7	PKW Service
	PKW Request data

TeSys U C Mu L and TeSys U C Mu R Input Data Map

Controller with Multifunction Control Unit Local and Remote

Input Data Map = 8 words		
Word	Register	Description
1	455	Status register
2	458	I/O status register
3	461	Warning register
4	457	Mechanical and power supply status register
5	PKW1	PKW request object
6	PKW2	
7	PKW3	PKW request data
8	PKW4	

Word 1	Register 455 - Status register
Bit 0	Ready: LUB**/2B** = the rotary handle is turned to 'On' position and there is no fault. LUS**/2S** = the push-button is pressed and there is no fault.
Bit 1	Input I.3 or I.4 powered-on
Bit 2	All fault
Bit 3	All warning
Bit 4	Tripped: LUB**/2B** = the rotary handle is turned to "Trip" position. LUS**/2S** = the push-button is depressed.
Bit 5	Fault reset authorized
Bit 6	Input I.1 or I.2 powered-on
Bit 7	Motor running with detection of current, if greater than 10% FLA
Bit 8 to bit 13	Average motor current in % of FLA. 32 = 100%, 63 = 200%
Bit 14	In local control
Bit 15	Motor start in progress 1 = ascending current is greater than 10% FLA 0 = descending current is lower than 150% FLA

Word 2	Register 458 - I/O Status
Bit 0	OA1 status
Bit 1	OA3 status
Bit 2	LO1 status
Bit 3 to bit 7	Reserved
Bit 8	LI1 status
Bit 9	LI2 status
Bit 10 to bit 15	Reserved

Word 3	Register 461 - Warning register
Bit 0 to bit 1	Reserved
Bit 2	Ground fault warning
Bit 3	Thermal warning
Bit 4	Long start warning
Bit 5	Jam warning
Bit 6	Phase imbalance warning
Bit 7	Under-current warning
Bit 8 to bit 9	Reserved
Bit 10	Communication port on LUCM Modbus port
Bit 11	Internal temperature warning
Bit 12	Module identification or internal communication warning
Bit 13 to bit 14	Reserved
Bit 15	Module warning

Word 4	Register 459 - I/O status on controller base
Bit 0	I.1 = local control of output 13
Bit 1	I.2 = local control of output 23
Bit 2	I.3 = contactor status on output 13
Bit 3	I.4 = contactor status on output 23
Bit 4	I.5 = input status (reset)
Bit 5	I.6 = input status (external fault)
Bit 6	I.7 = input status (system ready)
Bit 7	I.8 = input status (free)
Bit 8	I.9 = input status (free)
Bit 9	I.10 = input status in local/remote mixed mode if 683 = 2, otherwise free
Bit 10 to bit 11	Reserved
Bit 12	Output 13 status (1 = OA1 closed)
Bit 13	Output 23 status (1 = OA2 closed)
Bit 14	Output 95-96 and 97-98 status (1 = 95-96 closed and 97-98 opened)
Bit 15	Output 05-06 status (1 = 05-06 closed)

Word 5 and 6	PKW Service
	PKW Request object

Word 7 and 8	PKW Service
	PKW Request data

Using PKW Objects

Introduction

PKW stands for **P**eriodically **K**ept in **A**cyclic **W**ords. PKW objects are added to the process data images to allow to acyclically read or write any register.

4 words are reserved in the output process image to activate a request telegram.

4 words are reserved in the input process image to provide a response telegram.

Using PKW, the PLC application can read or write any register of TeSys U in remote mode. In local mode, the PLC application can only read registers.

PKW OUT Data

The following table describes the Request OUT Data:

		MSB		LSB
PKW Request Object	PKW OUT Word 1	address		
	PKW OUT Word 2	Toggle bit (bit 7)	Function code (bits 6 to 0)	0x00
PKW Request Data	PKW OUT Word 3	Value to write: 1st word = Most Significant Word		
	PKW OUT Word 4	Value to write: 2nd word = Least Significant Word		

Any changes in the PKW OUT Data area will trigger the handling of the request, except if function code = 0x00).

The toggle bit must change for each consecutive request.

This mechanism allows the request initiator to know when a response is ready by polling bit 7 of function code. When this bit in the OUT data equals the request's emitted toggle bit in the IN data in the PKW Response Object, then the response is ready.

Function code allows the selection of read or write access to single or double words:

Access Type	Data Size	Function Code (bits 6 to 0)	
Read	Single Word	R_MB_16	0x25
	Double Word	R_MB_32	0x26
Write	Single Word	W_MB_16	0x2A
	Double Word	W_MB_32	0x2B

PKW IN Data

The following table describes the Request IN Data:

		MSB		LSB
PKW Response Object	PKW IN Word 1	Same as request: address		
	PKW IN Word 2	Toggle bit (bit 7)	Function code (bits 6 to 0)	0x00
PKW Response Data	PKW IN Word 3	Read data: 1st word = Most Significant Word or Error code		
	PKW IN Word 4	Read data: 2nd word = Least Significant Word or Error code		

If the initiator tries to write a TeSys U object/register to an illegal value, or tries to access an unreachable register, an error code is answered (Function code = toggle bit + 0x4E).

The exact error code can be found in PKW IN Word 3. The request is not accepted and the object/register remains at the old value. This also happens if an access is requested with an incorrect data type (example: R_MB_16 for reading a 32 bits TeSys U register).

If you want to repeat exactly the same command, it would require you to reset the function code to 0x00, wait for the response frame with the function code equal to 0x00 and then to set it again to its previous value (useful for limited master like HMI).

Another way of repeating exactly the same command is to invert the "toggle bit" in the function code byte. The response is valid when the toggle bit of the response is equal to the toggle bit written in the answer (this is a more efficient method, but it requires higher programming capabilities).

PKW Error Codes

The following table provides a list of possible errors:

Error Code	Description
0x0601 0000	Unsupported access to an object.
0x0601 0002	Attempt to write a read only object.
0x0602 0000	Object does not exist in the object dictionary.
0x0609 0030	Value range of parameter is exceeded (only for write access)
0x0609 0031	Value of parameter written is too high.
0x0609 0032	Value of parameter written is too low.
0x0609 0036	Maximum value is less than the minimum value

Overview of the Main Registers for Simplified Management

Introduction

Before commissioning a motor starter, it is useful to know which registers to access, and in which order.

Illustration of Registers Used

The following illustration provides basic information about commissioning through registers: configuration, control and monitoring (state of the system, measurements, faults and warnings, acknowledgment). Starting from the predefined factory configuration, you will be able to visualize, and even anticipate the behavior of your system.

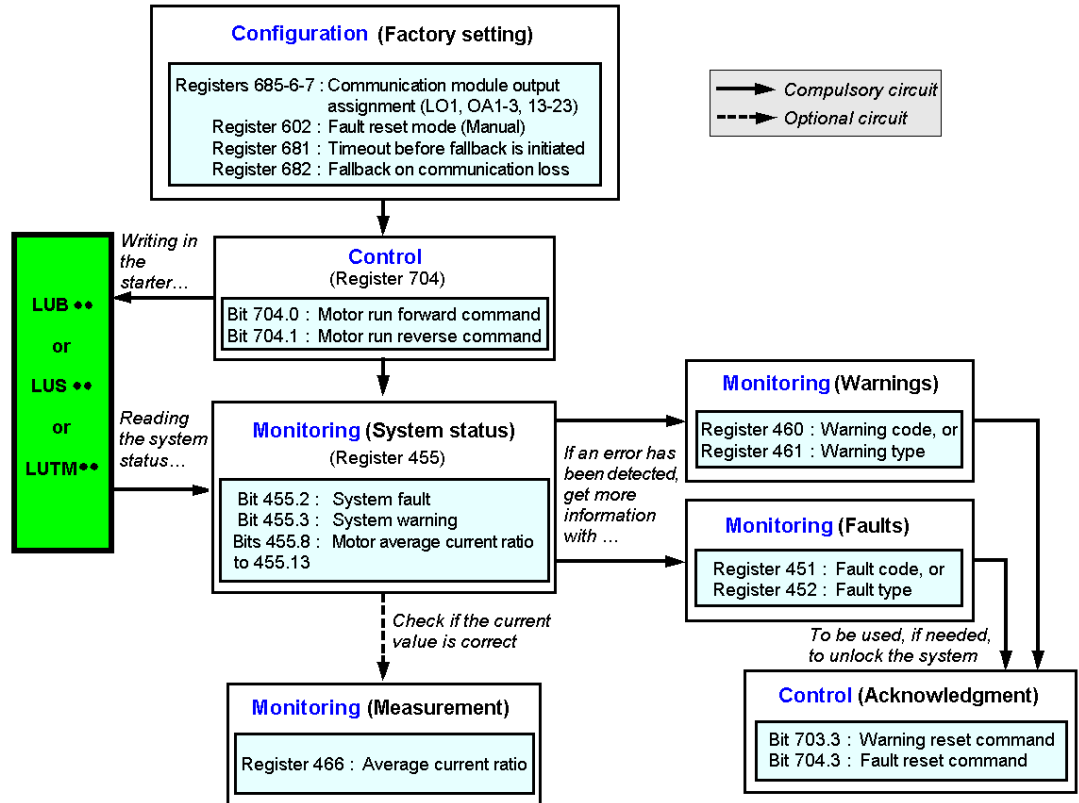

Managing Faults and Warnings

4

What's in this Chapter?

This chapter contains the following topics:

Topic	Page
Displaying Faults	62
Application Faults	63
Internal Faults	65
Warnings - Loss of Communication	66

Displaying Faults

Fault Indicators

The presence of a fault is signalled by different indicators:

- State of the LULC15 communication module's LEDs

With a power base:

- State of the power base rotary knob (0 or "trip"),
- State of the PKW request (PKW response)
- State of the output relays

With a controller base:

- State of the LEDs on the controller base
- State of the output relays

With a standard or advanced control unit:

- Internal signals sent to the LULC15 communication module

With a multifunction control unit:



- Warning
- Message(s) displayed on screen
- Internal communication with the LULC15 communication module



NOTE: Warnings and faults are taken into account in the relevant registers. For more information, see *Communication Variables User's Manual*: monitoring of faults (450 to 452) and monitoring of warnings (460 to 461).

Application Faults

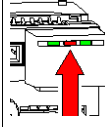
Acknowledgment of Application Faults

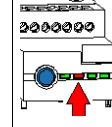
Possible application faults are listed below. Their reset (or acknowledgement): method can be manual/automatic/ remote.

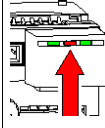
Application faults	Registers		LULC15	LUCM•	LUTM	Fault acknowledgement
	451 Fault number	452 Fault bit	 "ERR"	 (line 2)	 "FAULT"	
Short-circuit fault	1	_.0 = 1	off	Sc	-	Manual reset
Over-current fault	2	_.1 = 1		I>>	-	
Thermal overload fault	4	_.3 = 1		overload	-	Depending on reset mode set in register 602
LUCM• multifunction control unit application fault	3 and 5 set to 12		See LUCM••BL - LUCMT1BL Multifunction Control Unit User's Manual			

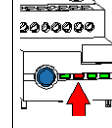
Warnings	Registers		LULC15	LUCM•	LUTM	Warning acknowledgement
	460 Fault number	461 Fault bit	 "ERR"	 (line2)	 "FAULT"	
LUTM external warning indicated by I.6 changing to 0	201	_.15 = 1	-	M201	See LUTM Controller User's Manual	Automatic with I.6 returning to 1

Overload Fault with LU•B•/LU•S• Power Base

Following a thermal overload fault, either the rotary knob or the blue pushbutton on the front panel can be used, irrespective of which reset mode has been configured..

Configuration register	Reset (acknowledgment)	Method
602.0 = 1	direct "manual"	With the rotary knob on LU•B• With the blue pushbutton on LU•S•
	remote "manual"	With the LU9 AP•• kit on LU•B• With the LU9 •• kit on LU•S•
602.1 = 1	"remote"	Acknowledgement by bit 704.3. This bit is active on rising edge and must be reset to 0 by programming.
602.2 = 1	"automatic"	Managed by the control unit

Overload Fault with LUTM Controller Base



Following a thermal overload fault, either the blue pushbutton on the front panel or input I.5 can be used, irrespective of which reset mode has been configured.

Configuration register	Acknowledgment (reset)	Means
602.0 = 1	direct "manual"	With the blue push-button on the front panel
	remote "manual"	With the reset button on front of the rack or control panel (via input I.5)
602.1 = 1	"remote"	Acknowledgement by bit 704.3. This bit is active on rising edge and must be reset to 0 by programming.
602.2 = 1	"automatic"	Managed by the control unit

Internal Faults

Acknowledgement of Internal Faults

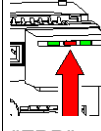
List of possible internal faults:

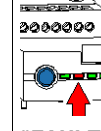
Internal faults	Registers		LULC15	LUCM•	LUTM	Fault acknowledgement
	451 Fault number	452 Fault bit	 "ERR"	 (line 2)	 "FAULT"	
Fault in the LULC15 STB communication module	14	-	Off	M14	-	Power down and then power up the LULC15 and LUCM•
LULC15 STB communication module not installed or not supplied with power, or loss of communication with the module	15	-		M15	-	
Internal fault in the LUC•• control unit	54	_.11 = 1		M54	-	
Internal fault in the LUCM• multifunction control unit	51 to 53, 55 to 63	<i>See LUCM - LUCMT Multifunction Control Unit User's Manual</i>				
Write-to-EEPROM fault	100	_.13 = 1	On	M100	-	LULC15 power off then on
Communication fault with the LUCM• multifunction control unit	101	_.12 = 1	On	M101	Flashing	LULC15 power off then on
Checksum fault in EEPROM	102	_.13 = 1	On	M102		Rising edge on 704.3=1
EEPROM configuration fault	104	_.13 = 1	On	M104		Rising edge on 704.3=1
Communication fault with LUTM controller base	105	_.13 = 1	On	M105		Power down and then power up the LULC15
Communication fault with LULC15 module	205	_.13 = 1	On	-	See LUTM User's Manual	Power down and then power up the LULC15
No control unit	206					Power down and then power up the LULC15

Warnings - Loss of Communication

Acknowledgment of Warnings

List of possible warnings.

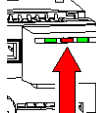
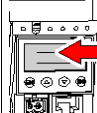
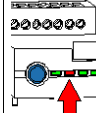
Warnings	Registers		LULC15	LUCM•	LUTM	warning acknowledgment
	460 warning number	461 warning bit	 "ERR"	 (line 1)	 "FAULT"	
Thermal overload warning	4	_.3 = 1	-	Wrng overload	-	Automatic when the overload is less than 85%
Loss of communication with the master warning	109	_.15 = 1	Flashing	Comm loss	-	Acknowledgement by bit 703.3. This bit is active on rising edge and must be reset to 0 by programming.
LUCM•/LUTM• multifunction control unit warning	2 and 4 to 13	<i>See LUCM - LUCMT Multifunction Control Unit User's Manual</i>				

Recovery after Communication Loss

After acknowledgment by setting bit 703.3 to 1, recovery occurs according to the states of control bits 704.0 and 704.1.

Configuration of Reflex Stop Functions

5

What's in this Chapter?

This chapter contains the following topics:

Topic	Page
Description of Reflex Stop Functions	68
Use of Reflex 1 and Reflex 2	70

Description of Reflex Stop Functions

Introduction

The reflex stop ensures accurate repeated position control, unhindered by the bus and PLC scan times.

There are 2 types of reflex stop functions:

- Reflex1: "Reflex stop 1" function
- Reflex2: "Reflex stop 2" function.

Description of Reflex1

Sensor 1 (logic input LI1) directly controls motor stopping.

After a new run command (stop command then run command), the motor restarts even if something is still detected (LI1=1).

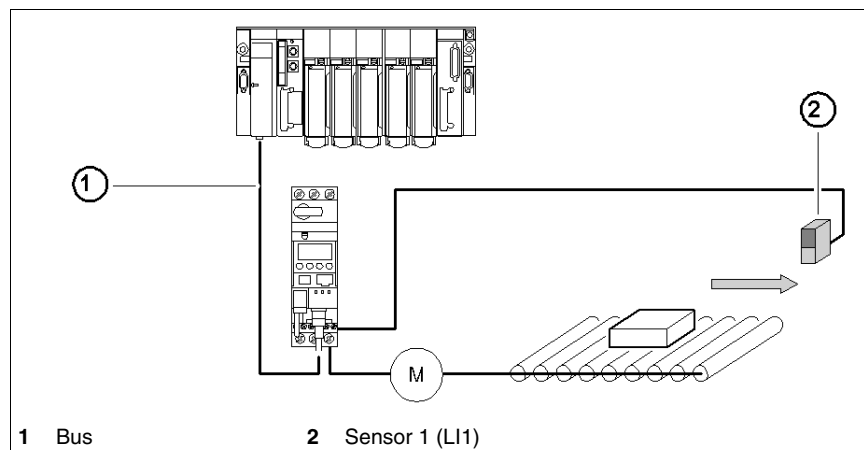

NOTE: In the case of a reversing starter, the reflex stop works in both directions.

Data sequence:

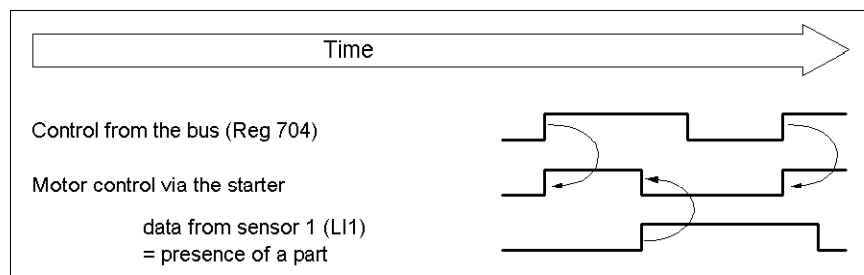

Description of Reflex2

Sensor no. 1 (logic input LI1) controls motor stopping in forward mode.

Sensor no. 2 (logic input LI2) controls motor stopping in reverse mode.

After a new run command (stop command then run command), the motor restarts even if something is still detected (LI1 or LI2 = 1).

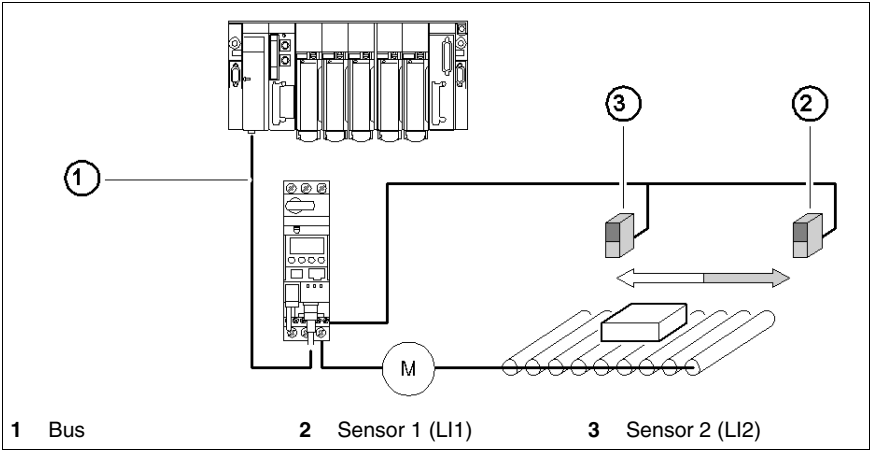

NOTE: Sensor no. 2 (LI2) does not affect forward mode, and sensor no.1 (LI1) does not affect reverse mode.

Use of Reflex 1 and Reflex 2

Introduction

In order to use a "reflex stop" function, it must be selected in the register of the output to be monitored.

Reflex function	Motor spinning direction	Value of Reg*	LUB**/S** - LU2B**/2S** base		LUTM** base
			Output LO1	Outputs OA1 and OA3	Outputs 13 and 23
Reflex1	Reflex1.Fw = Forward	8	Reg685 (LSB)	Reg686 (LSB) (MSB)	Reg687 (LSB) (MSB)
	Reflex1.Rev = Reverse	9			
Reflex2	Reflex2.Fw = Forward	10			
	Reflex2.Rev = Reverse	11			

NOTE: Before using the "reflex stop" functions, outputs OA1/OA3 must first be assigned to the forward/reverse directions. This selection is made in register 686. By default, OA1 is assigned to forward and OA3 to reverse.

Reflex1.Fw

This function is active on a rising edge, and not on the level.

.Fw	LI1 = 1 stops the motor, irrespective of the chosen direction of operation. After a new run command (stop command followed by a run command), even if logic input LI1 = 1, the motor restarts in the chosen direction.
-----	---

NOTE: Logic input LI2 is not used.

Reflex1.Rev

This function is active on a rising edge, and not on the level.

.Rev	LI1 = 1 stops the motor, irrespective of the chosen direction of operation. After a new run command (stop command followed by a run command), even if logic input LI1 = 1, the motor restarts in the chosen direction.
------	---

NOTE: Logic input LI2 is not used.

Reflex2.Fw

This function is active on a rising edge, and not on the level

.Fw	LI1 = 1 stops the motor in forward mode. LI2 = 1 stops the motor in reverse mode. After a new run command (stop command followed by a run command), even if logic input LI1 = 1, the motor restarts in the chosen direction.
-----	--

NOTE: Logic input LI2 doesn't affect forward mode and logic input LI1 doesn't affect reverse mode.

Reflex2.Rev

This function is active on a rising edge, and not on the level.

.Rev	LI1 = 1 stops the motor in forward mode. LI2 = 1 stops the motor in reverse mode. After a new run command (stop command followed by a run command), even if logic input LI1 = 1, the motor restarts in the chosen direction.
------	--

NOTE: Logic input LI2 doesn't affect forward mode and logic input LI1 doesn't affect reverse mode.

Index

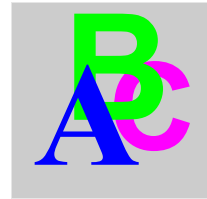

A

Acknowledgement
 application fault, 63
 internal fault, 65
 warning, 66
Application faults, 63
Architecture, 24
architecture limitations, 26
Assembly Order, 19

C

Communication loss, 38, 66
Configuration
 Inversion of Output , 40
 output, 40
Connection, 25
Connectors, 15
Control mode, 40
Control units (LUC...), 14
Controller base, 19

E

Electrical connection, 20

F

Fallback mode, 38
Faults, 62
Functions Offered, 13

I

I/O words exchanges, 26
Input (on illustration), 15
Inputs, 30
Internal faults, 65
Island bus extension cable, 15

L

LED, 15, 16
Link
 prewired, 22
 wire-to-wire, 22
LUCA, 14
LUCB/C/D, 14
LUCM, 14, 21

M

Modbus
 Reflex1, 68
 Reflex2, 69
Module
 bottom view, 18
 front view, 15

O

Output
 Configuration, 40
Output (on illustration), 15
Outputs, 30

P

Power base, 19
Power supply, 20, 21, 22, 29
Power-up, 21
Product dimensions, 29

R

Receiving the product, 13
Reflex stop functions, 68
reset mode, 38

T

TeSys U mix, 27
TeSys U per NIM, 27

W

Warning, 66
wire, 23

