

# SH3

## Servo Motor

## Motor Manual

01/2017

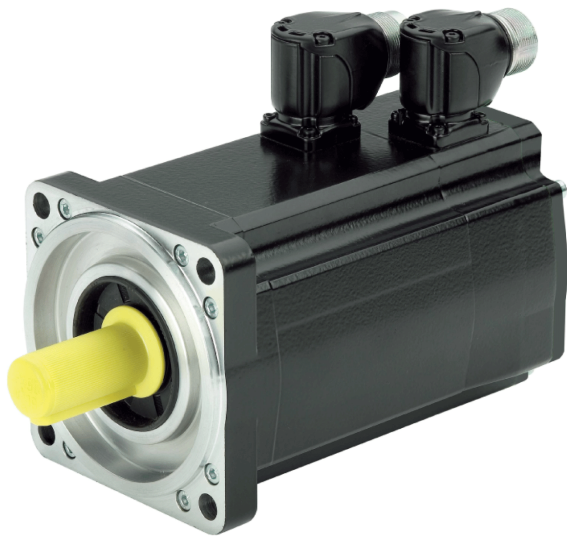

---

The information provided in this documentation contains general descriptions and/or technical characteristics of the performance of the products contained herein. This documentation is not intended as a substitute for and is not to be used for determining suitability or reliability of these products for specific user applications. It is the duty of any such user or integrator to perform the appropriate and complete risk analysis, evaluation and testing of the products with respect to the relevant specific application or use thereof. Neither Schneider Electric nor any of its affiliates or subsidiaries shall be responsible or liable for misuse of the information contained herein. If you have any suggestions for improvements or amendments or have found errors in this publication, please notify us.

No part of this document may be reproduced in any form or by any means, electronic or mechanical, including photocopying, without express written permission of Schneider Electric.

All pertinent state, regional, and local safety regulations must be observed when installing and using this product. For reasons of safety and to help ensure compliance with documented system data, only the manufacturer should perform repairs to components.

When devices are used for applications with technical safety requirements, the relevant instructions must be followed.

Failure to use Schneider Electric software or approved software with our hardware products may result in injury, harm, or improper operating results.

Failure to observe this information can result in injury or equipment damage.

© 2017 Schneider Electric. All Rights Reserved.

---

# Table of Contents

---



	<b>Safety Information</b> .....	5
	<b>About the Book</b> .....	7
<b>Chapter 1</b>	<b>Introduction</b> .....	11
	Motor Family .....	12
	Options and Accessories .....	12
	Nameplate .....	13
	Type Code .....	15
<b>Chapter 2</b>	<b>Technical Data</b> .....	17
	General Characteristics .....	18
	Environmental Conditions .....	20
	Approved Drives .....	22
	Dimensions .....	23
	Shaft-Specific Data .....	33
	Motor-Specific Data .....	36
	Encoder .....	47
	Holding Brake .....	49
	Certifications .....	50
	Conditions for UL 1004-1, UL 1004-6 and CSA 22.2 No. 100 .....	50
<b>Chapter 3</b>	<b>Installation</b> .....	51
3.1	Electromagnetic Compatibility (EMC) .....	53
	Electromagnetic Compatibility (EMC) .....	53
3.2	Mechanical Installation .....	55
	Before Mounting .....	56
	Cable Specifications .....	58
	Mounting The Motor .....	61
	Compressed Air Connection .....	63
3.3	Electrical Installation .....	64
	Connectors and Connector Assignments .....	65
	Power and Encoder Connection .....	68
	Holding Brake Connection .....	70
<b>Chapter 4</b>	<b>Commissioning</b> .....	71
	Commissioning .....	71
<b>Chapter 5</b>	<b>Diagnostics and Troubleshooting</b> .....	73
	Mechanical Issues .....	74
	Electrical Issues .....	74
<b>Chapter 6</b>	<b>Accessories and Spare Parts</b> .....	75
	IP67 Kit .....	76
	Motor Cables .....	77
	Encoder Cables .....	80
<b>Chapter 7</b>	<b>Service, Maintenance, and Disposal</b> .....	81
	Service Addresses .....	82
	Maintenance .....	82
	Replacing the Motor .....	84
	Shipping, Storage, Disposal .....	85
<b>Glossary</b>	.....	87
<b>Index</b>	.....	89

---



## Important Information

### NOTICE

Read these instructions carefully, and look at the equipment to become familiar with the device before trying to install, operate, service, or maintain it. The following special messages may appear throughout this documentation or on the equipment to warn of potential hazards or to call attention to information that clarifies or simplifies a procedure.



The addition of this symbol to a “Danger” or “Warning” safety label indicates that an electrical hazard exists which will result in personal injury if the instructions are not followed.



This is the safety alert symbol. It is used to alert you to potential personal injury hazards. Obey all safety messages that follow this symbol to avoid possible injury or death.

### **DANGER**

**DANGER** indicates a hazardous situation which, if not avoided, **will result in** death or serious injury.

### **WARNING**

**WARNING** indicates a hazardous situation which, if not avoided, **could result in** death or serious injury.

### **CAUTION**

**CAUTION** indicates a hazardous situation which, if not avoided, **could result in** minor or moderate injury.

### **NOTICE**

**NOTICE** is used to address practices not related to physical injury.

### PLEASE NOTE

Electrical equipment should be installed, operated, serviced, and maintained only by qualified personnel. No responsibility is assumed by Schneider Electric for any consequences arising out of the use of this material.

A qualified person is one who has skills and knowledge related to the construction and operation of electrical equipment and its installation, and has received safety training to recognize and avoid the hazards involved.

---

---

# About the Book



## At a Glance

### Document Scope

This manual describes technical characteristics, installation, commissioning, and maintenance of the servo motors SH3.

### Validity Note

This manual is valid for the standard products listed in the chapter Type Code.

For product compliance and environmental information (RoHS, REACH, PEP, EOLI, etc.), go to [www.schneider-electric.com/green-premium](http://www.schneider-electric.com/green-premium).

The technical characteristics of the devices described in this document also appear online. To access this information online:

Step	Action
1	Go to the Schneider Electric home page <a href="http://www.schneider-electric.com">www.schneider-electric.com</a> .
2	In the <b>Search</b> box type the reference of a product or the name of a product range. <ul style="list-style-type: none"><li>• Do not include blank spaces in the reference or product range.</li><li>• To get information on grouping similar modules, use asterisks (*).</li></ul>
3	If you entered a reference, go to the <b>Product Datasheets</b> search results and click on the reference that interests you. If you entered the name of a product range, go to the <b>Product Ranges</b> search results and click on the product range that interests you.
4	If more than one reference appears in the <b>Products</b> search results, click on the reference that interests you.
5	Depending on the size of your screen, you may need to scroll down to see the data sheet.
6	To save or print a data sheet as a .pdf file, click <b>Download XXX product datasheet</b> .

The characteristics that are presented in this manual should be the same as those characteristics that appear online. In line with our policy of constant improvement, we may revise content over time to improve clarity and accuracy. If you see a difference between the manual and online information, use the online information as your reference.

### Product Related Information

The use and application of the information contained herein require expertise in the design and programming of automated control systems.

Only you, the user, machine builder or integrator, can be aware of all the conditions and factors present during installation and setup, operation, repair and maintenance of the machine or process.

You must also consider any applicable standards and/or regulations with respect to grounding of all equipment. Verify compliance with any safety information, different electrical requirements, and normative standards that apply to your machine or process in the use of this equipment.

Many components of the equipment, including the printed circuit board, operate with mains voltage, or present transformed high currents, and/or high voltages.

The motor itself generates voltage when the motor shaft is rotated.

## DANGER

### ELECTRIC SHOCK, EXPLOSION, OR ARC FLASH

- Disconnect all power from all equipment including connected devices prior to removing any covers or doors, or installing or removing any accessories, hardware, cables, or wires.
- Place a "Do Not Turn On" or equivalent hazard label on all power switches and lock them in the non-energized position.
- Wait 15 minutes to allow the residual energy of the DC bus capacitors to discharge.
- Measure the voltage on the DC bus with a properly rated voltage sensing device and verify that the voltage is less than 42.4 Vdc.
- Do not assume that the DC bus is voltage-free when the DC bus LED is off.
- Block the motor shaft to prevent rotation prior to performing any type of work on the drive system.
- Do not create a short-circuit across the DC bus terminals or the DC bus capacitors.
- Replace and secure all covers, accessories, hardware, cables, and wires and confirm that a proper ground connection exists before applying power to the unit.
- Use only the specified voltage when operating this equipment and any associated products.

**Failure to follow these instructions will result in death or serious injury.**

This equipment has been designed to operate outside of any hazardous location. Only install this equipment in zones known to be free of a hazardous atmosphere.

## DANGER

### POTENTIAL FOR EXPLOSION

Install and use this equipment in non-hazardous locations only.

**Failure to follow these instructions will result in death or serious injury.**

If the power stage is disabled unintentionally, for example as a result of a power outage, errors or functions, the motor is no longer decelerated in a controlled way. Overload, errors or incorrect use may cause the holding brake to no longer operate properly and may result in premature wear.

## WARNING

### UNINTENDED EQUIPMENT OPERATION

- Verify that movements without braking effect cannot cause injuries or equipment damage.
- Verify the function of the holding brake at regular intervals.
- Do not use the holding brake as a service brake.
- Do not use the holding brake for safety-related purposes.

**Failure to follow these instructions can result in death, serious injury, or equipment damage.**



## WARNING

### LOSS OF CONTROL

- The designer of any control scheme must consider the potential failure modes of control paths and, for certain critical control functions, provide a means to achieve a safe state during and after a path failure. Examples of critical control functions are emergency stop and overtravel stop, power outage and restart.
- Separate or redundant control paths must be provided for critical control functions.
- System control paths may include communication links. Consideration must be given to the implications of unanticipated transmission delays or failures of the link.
- Observe all accident prevention regulations and local safety guidelines.<sup>1</sup>
- Each implementation of this equipment must be individually and thoroughly tested for proper operation before being placed into service.

**Failure to follow these instructions can result in death, serious injury, or equipment damage.**

<sup>1</sup> For additional information, refer to NEMA ICS 1.1 (latest edition), "Safety Guidelines for the Application, Installation, and Maintenance of Solid State Control" and to NEMA ICS 7.1 (latest edition), "Safety Standards for Construction and Guide for Selection, Installation and Operation of Adjustable-Speed Drive Systems" or their equivalent governing your particular location.

### Terminology Derived from Standards

The technical terms, terminology, symbols and the corresponding descriptions in this manual, or that appear in or on the products themselves, are generally derived from the terms or definitions of international standards.

In the area of functional safety systems, drives and general automation, this may include, but is not limited to, terms such as *safety*, *safety function*, *safe state*, *fault*, *fault reset*, *malfunction*, *failure*, *error*, *error message*, *dangerous*, etc.

Among others, these standards include:

Standard	Description
EN 61131-2:2007	Programmable controllers, part 2: Equipment requirements and tests.
ISO 13849-1:2008	Safety of machinery: Safety related parts of control systems. General principles for design.
EN 61496-1:2013	Safety of machinery: Electro-sensitive protective equipment. Part 1: General requirements and tests.
ISO 12100:2010	Safety of machinery - General principles for design - Risk assessment and risk reduction
EN 60204-1:2006	Safety of machinery - Electrical equipment of machines - Part 1: General requirements
EN 1088:2008 ISO 14119:2013	Safety of machinery - Interlocking devices associated with guards - Principles for design and selection
ISO 13850:2006	Safety of machinery - Emergency stop - Principles for design
EN/IEC 62061:2005	Safety of machinery - Functional safety of safety-related electrical, electronic, and electronic programmable control systems
IEC 61508-1:2010	Functional safety of electrical/electronic/programmable electronic safety-related systems: General requirements.
IEC 61508-2:2010	Functional safety of electrical/electronic/programmable electronic safety-related systems: Requirements for electrical/electronic/programmable electronic safety-related systems.
IEC 61508-3:2010	Functional safety of electrical/electronic/programmable electronic safety-related systems: Software requirements.
IEC 61784-3:2008	Digital data communication for measurement and control: Functional safety field buses.
2006/42/EC	Machinery Directive
2014/30/EU	Electromagnetic Compatibility Directive
2014/35/EU	Low Voltage Directive

---

In addition, terms used in the present document may tangentially be used as they are derived from other standards such as:

Standard	Description
IEC 60034 series	Rotating electrical machines
IEC 61800 series	Adjustable speed electrical power drive systems
IEC 61158 series	Digital data communications for measurement and control – Fieldbus for use in industrial control systems

Finally, the term *zone of operation* may be used in conjunction with the description of specific hazards, and is defined as it is for a *hazard zone* or *danger zone* in the *Machinery Directive (2006/42/EC)* and *ISO 12100:2010*.

**NOTE:** The aforementioned standards may or may not apply to the specific products cited in the present documentation. For more information concerning the individual standards applicable to the products described herein, see the characteristics tables for those product references.

---

# Chapter 1

## Introduction

---

### What Is in This Chapter?

This chapter contains the following topics:

Topic	Page
Motor Family	12
Options and Accessories	12
Nameplate	13
Type Code	15

## Motor Family

The series SH3 motors are low-inertia AC synchronous servo motors designed for highly dynamic positioning tasks.

A drive system consists of the servo motor and the appropriate drive (*see page 22*). Maximum performance requires the motor and drive to be adapted to each other.

## Characteristics

The motors have the following features:

- Overload protection by integrated temperature sensor (external evaluation required)
- Low moment of inertia
- High power density
- Excellent dynamics
- High overload capability
- Broad torque range
- Special winding for low phase currents
- Motor connection via circular connectors
- Easy commissioning via electronic nameplate in SinCos encoder
- Low maintenance

## Options and Accessories

### Options

The motors are available with various options such as:

- Various encoder systems
- Holding brake
- Various shaft versions
- Various degrees of protection
- Various lengths
- Various sizes
- Various winding versions
- Various connection versions

### Accessories

Refer to the chapter Accessories and Spare Parts (*see page 75*).

## Nameplate

## SH3040

The nameplate contains the following data:

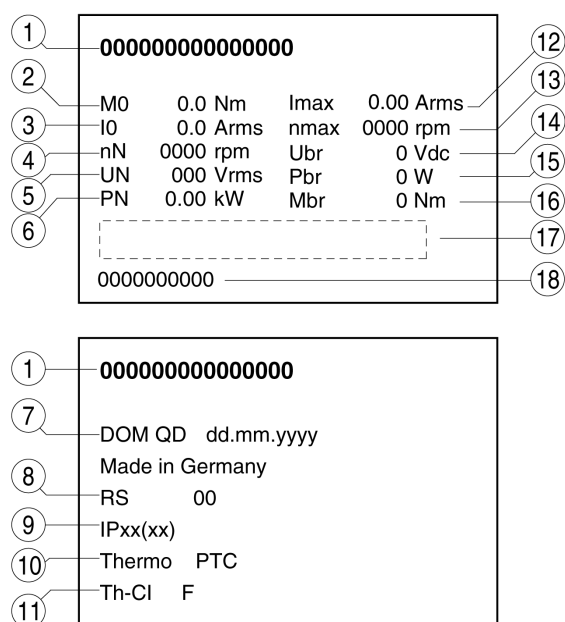

- 1 Motor type, see Type Code (*see page 15*)
- 2 Continuous stall torque
- 3 Continuous stall current
- 4 Nominal speed of rotation
- 5 Maximum nominal value of supply voltage
- 6 Nominal power
- 7 Date of manufacture
- 8 Hardware version
- 9 Degree of protection (housing without shaft bushing)
- 10 Temperature sensor
- 11 Thermal class
- 12 Maximum current
- 13 Maximum speed of rotation
- 14 Nominal voltage holding brake
- 15 Nominal power (electrical pull-in power) holding brake
- 16 Holding torque holding brake
- 17 Barcode
- 18 Serial number

## SH3055 ... SH3205

The nameplate contains the following data:

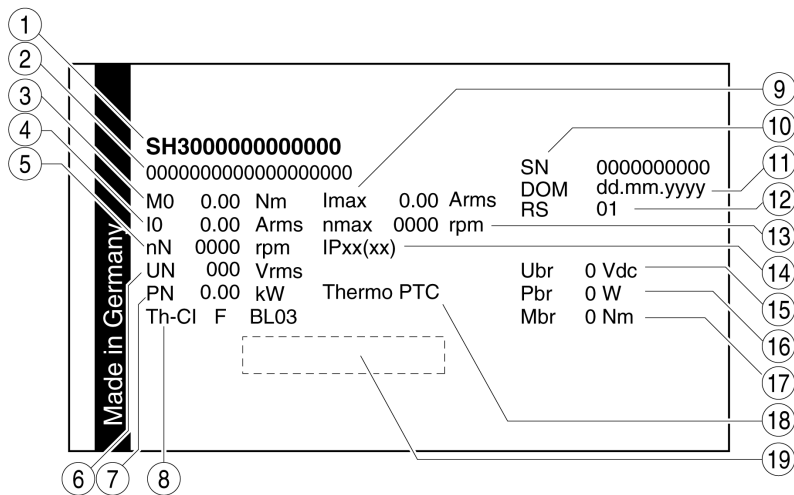

- 1 Motor type, see Type Code (*see page 15*)
- 2 Identification number
- 3 Continuous stall torque
- 4 Continuous stall current
- 5 Nominal speed of rotation
- 6 Maximum nominal value of supply voltage
- 7 Nominal power
- 8 Thermal class
- 9 Maximum Current
- 10 Serial number
- 11 Date of manufacture
- 12 Hardware version
- 13 Maximum speed of rotation
- 14 Degree of protection (housing without shaft bushing)
- 15 Nominal voltage holding brake
- 16 Nominal power (electrical pull-in power) holding brake
- 17 Holding torque holding brake
- 18 Temperature sensor
- 19 Barcode

## Type Code

### Type Code

Item	1	2	3	4	5	6	7	8	9	10	11	12	13	14	15
Type code (example)	S	H	3	0	7	0	1	P	0	1	A	1	0	0	0

Item	Meaning
1 ... 3	<b>Product family</b> SH3 = Synchronous motor - low moment of inertia
4 ... 6	<b>Size (housing)</b> 040 = 40 mm flange 055 = 55 mm flange 070 = 70 mm flange 100 = 100 mm flange 140 = 140 mm flange 205 = 205 mm flange
7	<b>Length</b> 1 = 1 stack 2 = 2 stacks 3 = 3 stacks 4 = 4 stacks
8	<b>Winding</b> M = Optimized in terms of high torque P = Optimized in terms of torque and speed of rotation S = Customized version
9	<b>Shaft</b> 0 = Smooth shaft 1 = Parallel key
10	<b>Encoder system</b> 1 = Absolute singleturn 128 Sin/Cos periods per revolution (SKS36) 2 = Absolute multiturn 128 Sin/Cos periods per revolution (SKM36) 6 = Absolute singleturn 16 Sin/Cos periods per revolution (SEK37) 7 = Absolute multiturn 16 Sin/Cos periods per revolution (SEL37)
11	<b>Holding brake</b> A = Without holding brake F = With holding brake
12	<b>Connection version</b> 1 = Straight connector 2 = Angular connector 90°, can be rotated
13	<b>Degree of protection shaft and housing - type of cooling<sup>1)</sup></b> 0 = Shaft IP54 without shaft sealing ring, housing IP65, convection 1 = Shaft IP65 with shaft sealing ring, housing IP65, convection 2 = Shaft IP65 with shaft sealing ring, housing IP67, convection
14 ... 15	<b>Versions</b> 00 = Standard
<b>1)</b> In the case of mounting position IM V3 (drive shaft vertical, shaft end upward), the motor has a degree of protection of IP 50.	

If you have questions concerning the type code, contact your Schneider Electric sales office.

### Designation Customized Version

In the case of a customized version, position 8 of the type code is an "S". The subsequent number defines the customized version. Example: SH30551S01A00

Contact your machine vendor if you have questions concerning customized versions.





---

# Chapter 2

## Technical Data

---

### What Is in This Chapter?

This chapter contains the following topics:

Topic	Page
General Characteristics	18
Environmental Conditions	20
Approved Drives	22
Dimensions	23
Shaft-Specific Data	33
Motor-Specific Data	36
Encoder	47
Holding Brake	49
Certifications	50
Conditions for UL 1004-1, UL 1004-6 and CSA 22.2 No. 100	50

## General Characteristics

Characteristic	Value	Standard
Motor type	AC synchronous servo motor	-
Thermal class	F (155 °C)	As per IEC 60034-1
Vibration grade	A	As per IEC 60034-14
Test voltage	> 2400 Vac	As per IEC 60034-1
Perpendicularity	normal class	As per IEC 60072-1, DIN 42955
Housing color	Black RAL 9005	-
Overvoltage category	III	As per IEC 61800-5-1
Protection class <sup>1)</sup>	I	As per IEC 61140, EN 50178
1) The signals of the holding brake and the temperature sensor at CN1 and the signals at CN2 meet the PELV requirements.		

## Service Life

Bearing service life	Unit	Value
Nominal bearing service life $L_{10h}^{1)}$	h	20000
1) Operating hours at a probability of failure of 10%		

The service life of the motors when operated correctly is limited primarily by the service life of the rolling bearing.

The following operating conditions significantly reduce the service life:

- Installation altitude >1000 m (3281 ft) above mean sea level
- Rotary movements exclusively within a fixed angle of <100°
- Operation under vibration load >20 m/s<sup>2</sup>
- Allowing sealing rings to run dry
- Contact of the seals with aggressive substances

## Compressed Air Connection

The compressed air generates a permanent overpressure inside the motor. This overpressure inside the motor is used to obtain degree of protection IP67.

Compressed air must also be available when the system is switched off, for example to maintain the required degree of protection during cleaning work. When the compressed air is switched off, the degree of protection is decreased to IP65. The degree of protection only relates to the motor itself, not to mounted components such as, for example, a gearbox.

Special compressed air must be used:

Characteristic	Unit	Value
Nominal pressure	bar (psi)	0.1 ... 0.3 (1.45 ... 4.35)
Maximum air pressure	bar (psi)	0.4 (5.8)
Permissible humidity	%	20 ... 30
Other properties of the compressed air		Free from dust, free from oil

**Tightening Torque and Property Class of Screws**

<b>Screw</b>	<b>Unit</b>	<b>Value</b>
Tightening torque of housing screws M3	Nm (lb•in)	1 (8.85)
Tightening torque of housing screws M4	Nm (lb•in)	1.5 (13.28)
Tightening torque of housing screws M5	Nm (lb•in)	5 (44.3)
Tightening torque protective ground conductor M3 (SH3040)	Nm (lb•in)	0.9 (7.97)
Tightening torque protective ground conductor M4 (SH3055, SH3070, SH3100)	Nm (lb•in)	2.9 (25.7)
Tightening torque protective ground conductor M6 (SH3140, SH3205)	Nm (lb•in)	9.9 (87.3)
Property class of the screws	-	8.8

## Environmental Conditions

### Conditions for Operation

Characteristic	Unit	Value
Class as per IEC 60721-3-3	-	3K3, 3Z12, 3Z2, 3B2, 3C1, 3M6
Ambient temperature <sup>1)</sup> (no icing, non-condensing)	°C (°F)	-20 ... 40 (-4 ... 104)
Ambient temperature with current derating of 1% per °C (per 1.8 °F) <sup>1)</sup>	°C (°F)	40 ... 60 (104 ... 140)
Relative humidity (non-condensing)	%	5 ... 85
Installation altitude <sup>2)</sup>	m (ft)	<1000 (<3281)
Installation altitude with current reduction of 1% per 100 m (328 ft) at altitudes of more than 1000 m (3281 ft) <sup>2)3)</sup>	m (ft)	1000 ... 3000 (3281 ... 9843)
<p>1) Limit values with flanged motor (steel plate, height and width = 2.5 * motor flange, 10 mm (0.39 in) thickness, centered hole).</p> <p>2) The installation altitude is defined in terms of altitude above mean sea level.</p> <p>3) For the correct functioning of the SH3040 motors, you must apply a separate surge protection device when operating between 2000 and 3000 m.</p>		

### Conditions for Transportation and Storage

The environment during transportation and storage must be dry and free from dust.

The storage time is primarily limited by the service life of the lubricants in the bearings. Do not store the product for more than 36 months and periodically operate the motor.

If the holding brake is not used for an extended period of time, parts of the holding brake may corrode. Corrosion reduces the holding torque. See chapter Inspecting/Breaking In the Holding Brake (*see page 83*).

Characteristic	Unit	Value
Temperature	°C (°F)	-40 ... 70 (-40 ... 158)
Relative humidity (non-condensing)	%	≤75
Set of class combinations as per IEC 60721-3-2		IE 21

### Vibration and Shock

For SH3040 ... SH3140

Characteristic	Value
Vibration, sinusoidal	Type test with 10 runs as per IEC 60068-2-6 0.15 mm (10 ... 60 Hz) 20 m/s <sup>2</sup> (60 ... 500 Hz)
Shock, semi-sinusoidal	Type test with 3 shocks in each direction as per IEC 60068-2-27 150 m/s <sup>2</sup> (11 ms)

For SH3205

Characteristic	Value
Vibration, sinusoidal	Type test with 10 runs as per IEC 60068-2-6 0.35 mm (10 ... 60 Hz) 50 m/s <sup>2</sup> (60 ... 150 Hz)
Continuous shock	Type test with 3 shocks in each direction as per IEC 60068-2-27 200 m/s <sup>2</sup> (6 ms)

### Compatibility with Foreign Substances

The motor has been tested for compatibility with many known substances and with the latest available knowledge. Nonetheless, you must perform a compatibility test prior to using a foreign substance.

### Degree of Protection

Characteristic	Unit	Value
Degree of protection motor housing	IP65	As per IEC 60034-5
Degree of protection shaft bushing without shaft sealing ring	IP54 <sup>1)</sup>	As per IEC 60034-5
Degree of protection shaft bushing with shaft sealing ring	IP65 <sup>1)</sup>	As per IEC 60034-5
With hardware version ≥RS03 Degree of protection version SH3••••••••1 without connected compressed air	Shaft IP65 Housing IP65	As per IEC 60034-5
With hardware version <RS03 Degree of protection version SH3••••••••2 without connected compressed air	Shaft IP65 Housing IP65	As per IEC 60034-5
With hardware version ≥RS03 Degree of protection version SH3••••~••••1 with connected compressed air	Shaft IP67 Housing IP67	As per IEC 60034-5
With hardware version <RS03 Degree of protection version SH3••~••••••••2 with connected compressed air	Shaft IP67 Housing IP67	As per IEC 60034-5
<b>1)</b> In the case of mounting position IM V3 (drive shaft vertical, shaft end up), the motor only has degree of protection IP50. The degree of protection only relates to the motor itself, not to mounted components such as, for example, a gearbox.		

The motors can be equipped with an optional shaft sealing ring. With a shaft sealing ring, they have degree of protection IP65. The shaft sealing ring limits the maximum speed of rotation to 6000 rpm.

Note the following:

- The shaft sealing ring is factory-pre-lubricated.
- If the seals run dry, this increases friction and greatly reduces the service life of the sealing rings.

## Approved Drives

Drive systems may perform unintended movements if unapproved combinations of drive and motor are used. Even if motors are similar, different adjustment of the encoder system may be a source of hazards. Even if the connectors for motor connection and encoder connection match mechanically, this does not imply that the motor is approved for use.

 <b>WARNING</b>
--

<b>UNINTENDED MOVEMENT</b>
----------------------------

Only use approved combinations of drive and motor.
--

<b>Failure to follow these instructions can result in death, serious injury, or equipment damage.</b>
---

The motor may be operated with the following drives:

- LXM52
- LXM62

When selecting, refer to the drive type and the level of mains voltage to select an appropriate drive product.

In accordance with our continual introduction of new product, consult your local representative for additional compatible drive products as they become available.

## Dimensions

### Dimensions SH3040

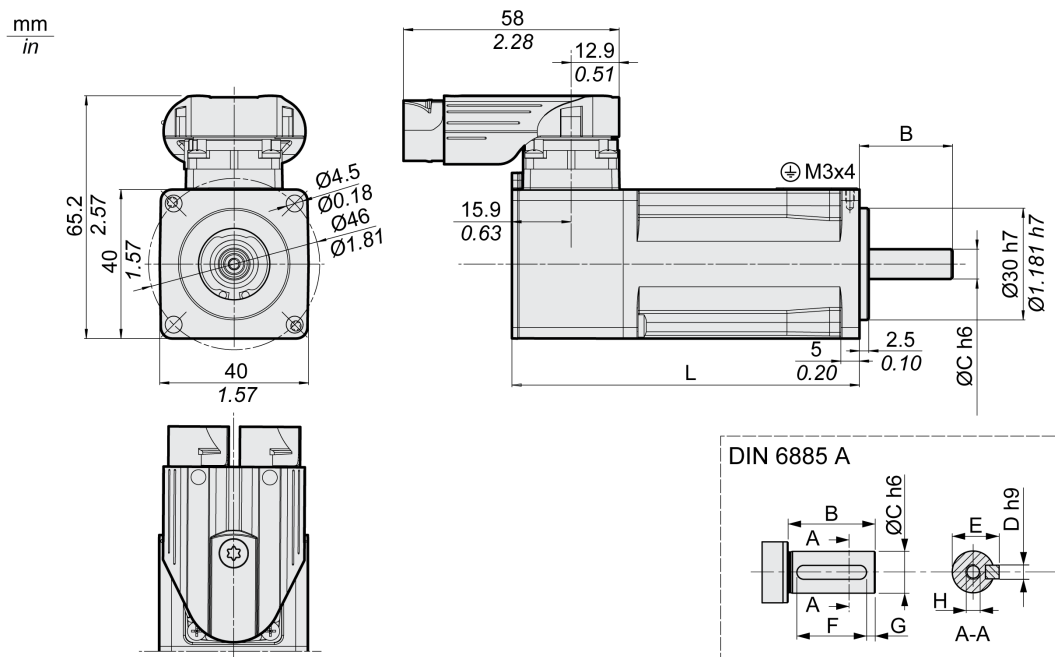

SH3...		0401	0402
L	Length without holding brake	mm (in) 73.4 (2.89)	93.4 (3.68)
L	Length with holding brake	mm (in) 99.4 (3.91)	119.4 (4.7)
B	Shaft length	mm (in) 25 (0.98)	25 (0.98)
C	Shaft diameter	mm (in) 8 (0.31)	8 (0.31)
D	Width of parallel key	mm (in) 3 (0.12)	3 (0.12)
E	Shaft width with parallel key	mm (in) 9.2 (0.36)	9.2 (0.36)
F	Length of parallel key	mm (in) 12 (0.47)	12 (0.47)
G	Distance parallel key to shaft end	mm (in) 4 (0.16)	4 (0.16)
H	Female thread of shaft	DIN 332 DS M3 x 9	DIN 332 DS M3 x 9
	Parallel key	DIN 6885-A3x3x12	DIN 6885-A3x3x12

Dimensions SH3055

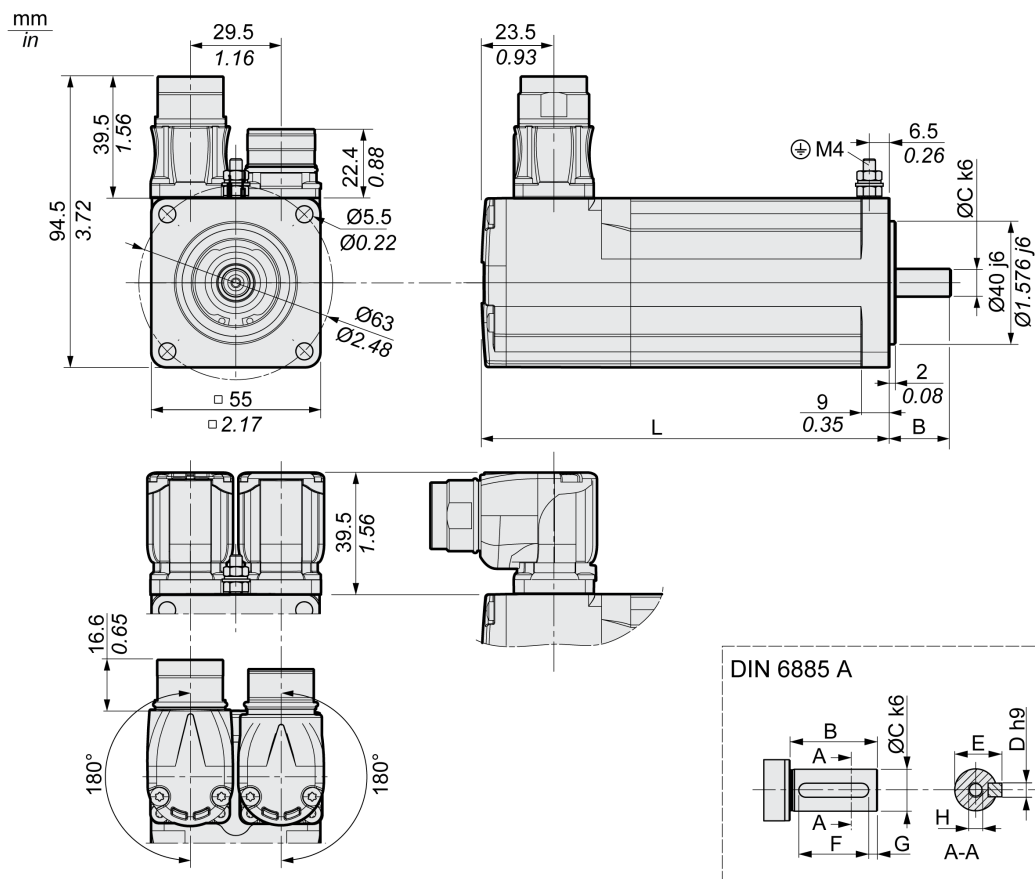

SH3...			0551	0552	0553
L	Length without holding brake	mm (in)	132.5 (5.22)	154.4 (6.08)	176.5 (6.95)
L	Length with holding brake	mm (in)	159 (6.26)	181 (7.13)	203 (7.99)
B	Shaft length	mm (in)	20 (0.79)	20 (0.79)	20 (0.79)
C	Shaft diameter	mm (in)	9 (0.35)	9 (0.35)	9 (0.35)
D	Width of parallel key	mm (in)	3 (0.12)	3 (0.12)	3 (0.12)
E	Shaft width with parallel key	mm (in)	10.2 (0.4)	10.2 (0.4)	10.2 (0.4)
F	Length of parallel key	mm (in)	12 (0.47)	12 (0.47)	12 (0.47)
G	Distance parallel key to shaft end	mm (in)	4 (0.16)	4 (0.16)	4 (0.16)
H	Female thread of shaft		DIN 332-D M3	DIN 332-D M3	DIN 332-D M3
	Parallel key		DIN 6885-A3x3x12	DIN 6885-A3x3x12	DIN 6885-A3x3x12



Dimensions SH3070

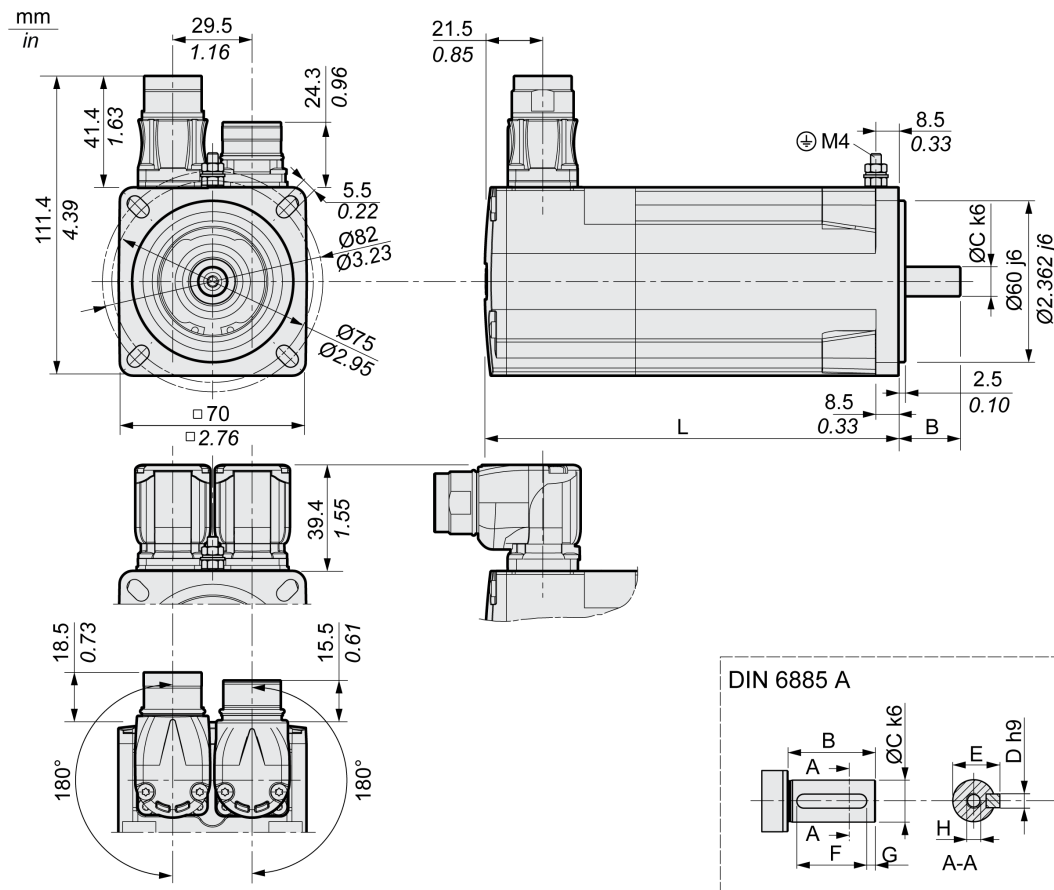

SH3...			0701	0702	0703
L	Length without holding brake	mm (in)	154 (6.06)	187 (7.36)	220 (8.66)
L	Length with holding brake	mm (in)	180 (7.09)	213 (8.39)	254 (10)
B	Shaft length	mm (in)	23 (0.91)	23 (0.91)	30 (1.18)
C	Shaft diameter	mm (in)	11 (0.43)	11 (0.43)	14 (0.55)
D	Width of parallel key	mm (in)	4 (0.16)	4 (0.16)	5 (0.2)
E	Shaft width with parallel key	mm (in)	12.5 (0.49)	12.5 (0.49)	16 (0.63)
F	Length of parallel key	mm (in)	18 (0.71)	18 (0.71)	20 (0.79)
G	Distance parallel key to shaft end	mm (in)	2.5 (0.1)	2.5 (0.1)	5 (0.2)
H	Female thread of shaft		DIN 332-D M4	DIN 332-D M4	DIN 332-D M5
	Parallel key		DIN 6885-A4x4x18	DIN 6885-A4x4x18	DIN 6885-A4x4x20

Dimensions SH3100

Hardware version ≥RS02:

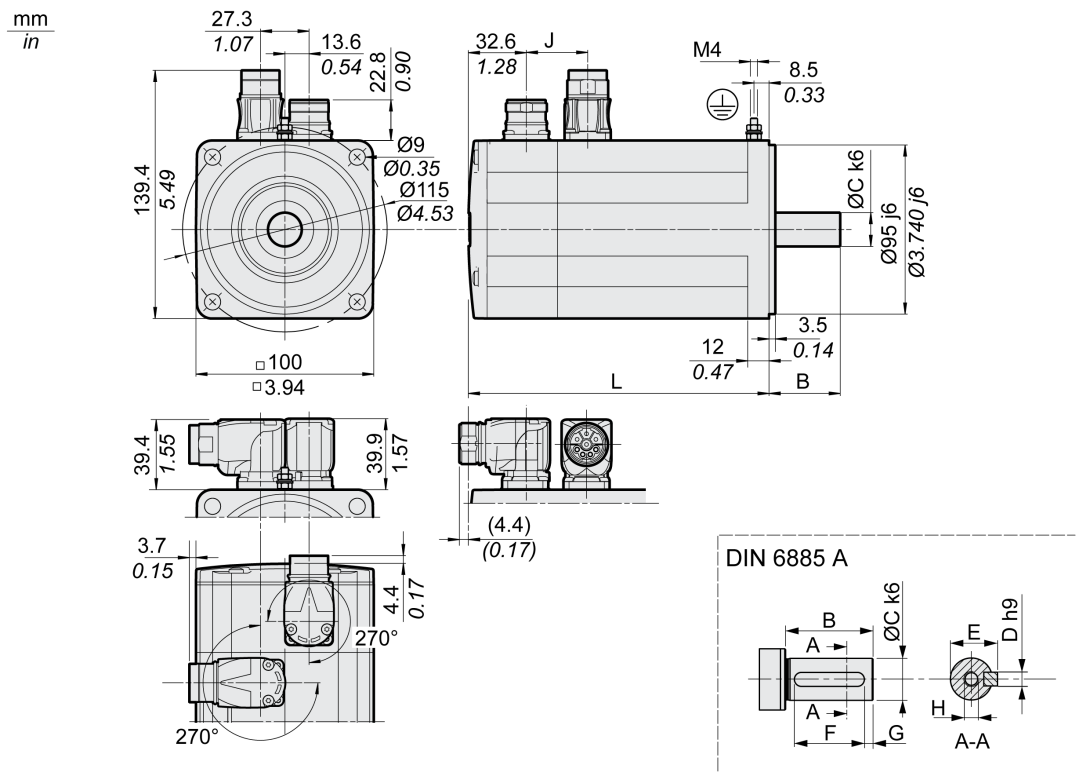

SH3...			1001	1002	1003	1004
L	Length without holding brake	mm (in)	168.5 (6.63)	204.5 (8.05)	240.5 (9.47)	276.5 (10.89)
L	Length with holding brake	mm (in)	199.5 (7.85)	235.5 (9.27)	271.5 (10.69)	307.5 (12.11)
B	Shaft length	mm (in)	40 (1.57)	40 (1.57)	40 (1.57)	50 (1.97)
C	Shaft diameter	mm (in)	19 (0.75)	19 (0.75)	19 (0.75)	24 (0.94)
D	Width of parallel key	mm (in)	6 (0.24)	6 (0.24)	6 (0.24)	8 (0.31)
E	Shaft width with parallel key	mm (in)	21.5 (0.85)	21.5 (0.85)	21.5 (0.85)	27 (1.06)
F	Length of parallel key	mm (in)	30 (1.18)	30 (1.18)	30 (1.18)	40 (1.57)
G	Distance parallel key to shaft end	mm (in)	5 (0.2)	5 (0.2)	5 (0.2)	5 (0.2)
H	Female thread of shaft		DIN 332-D M6	DIN 332-D M6	DIN 332-D M6	DIN 332-D M8
J	Connector distance without holding brake	mm (in)	34.5 (1.36)	34.5 (1.36)	34.5 (1.36)	34.5 (1.36)
J	Connector distance with holding brake	mm (in)	29.8 (1.17)	29.8 (1.17)	29.8 (1.17)	29.8 (1.17)
	Parallel key		DIN 6885-A6x6x30	DIN 6885-A6x6x30	DIN 6885-A6x6x30	DIN 6885-A8x7x40

Dimensions SH3100

Hardware version <RS02:

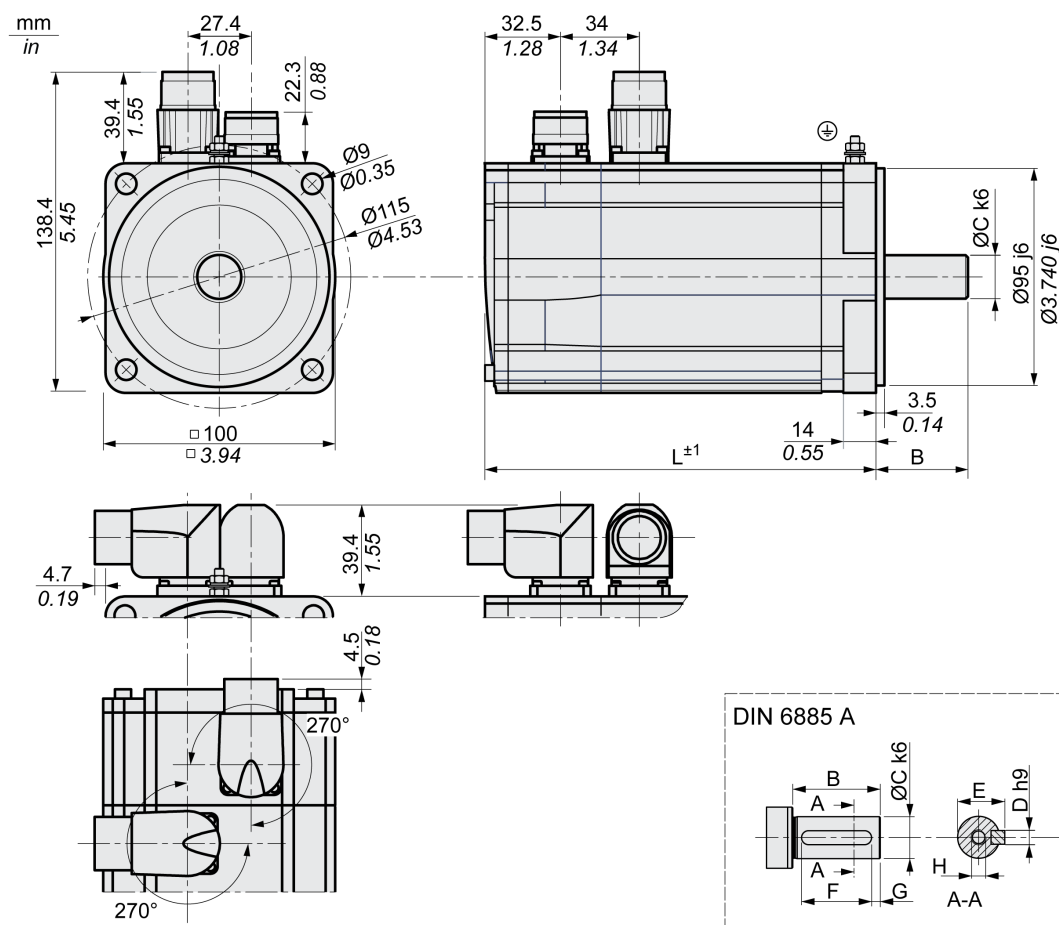

SH3...			1001	1002	1003	1004
L	Length without holding brake	mm (in)	168.5 (6.63)	204.5 (8.05)	240.5 (9.47)	276.5 (10.89)
L	Length with holding brake	mm (in)	199.5 (7.85)	235.5 (9.27)	271.5 (10.69)	307.5 (12.11)
B	Shaft length	mm (in)	40 (1.57)	40 (1.57)	40 (1.57)	50 (1.97)
C	Shaft diameter	mm (in)	19 (0.75)	19 (0.75)	19 (0.75)	24 (0.94)
D	Width of parallel key	mm (in)	6 (0.24)	6 (0.24)	6 (0.24)	8 (0.31)
E	Shaft width with parallel key	mm (in)	21.5 (0.85)	21.5 (0.85)	21.5 (0.85)	27 (1.06)
F	Length of parallel key	mm (in)	30 (1.18)	30 (1.18)	30 (1.18)	40 (1.57)
G	Distance parallel key to shaft end	mm (in)	5 (0.2)	5 (0.2)	5 (0.2)	5 (0.2)
H	Female thread of shaft		DIN 332-D M6	DIN 332-D M6	DIN 332-D M6	DIN 332-D M8
	Parallel key		DIN 6885-A6x6x30	DIN 6885-A6x6x30	DIN 6885-A6x6x30	DIN 6885-A8x7x40

Dimensions SH3140

Hardware version ≥RS02:

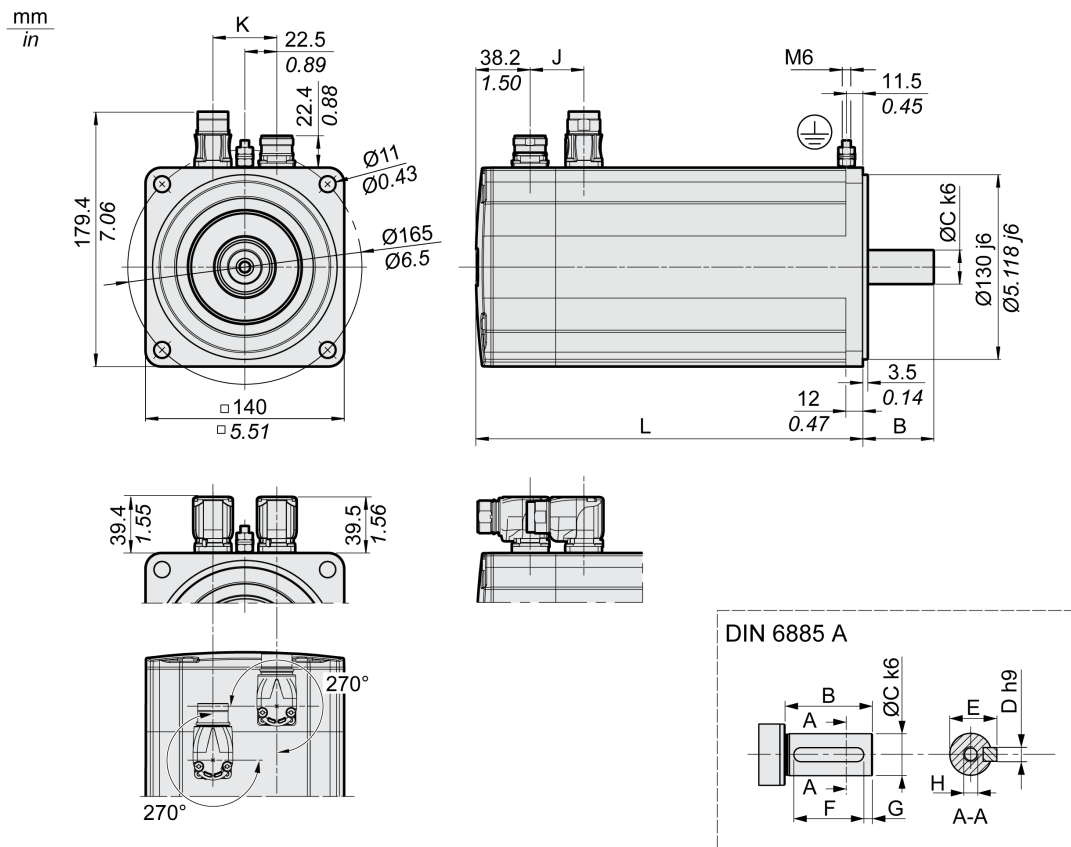

SH3...			1401	1402
L	Length without holding brake	mm (in)	217.5 (8.56)	272.5 (10.73)
L	Length with holding brake	mm (in)	255.5 (10.06)	310.5 (12.22)
B	Shaft length	mm (in)	50 (1.97)	50 (1.97)
C	Shaft diameter	mm (in)	24 (0.94)	24 (0.94)
D	Width of parallel key	mm (in)	8 (0.31)	8 (0.31)
E	Shaft width with parallel key	mm (in)	28 (1.1)	28 (1.1)
F	Length of parallel key	mm (in)	40 (1.57)	40 (1.57)
G	Distance parallel key to shaft end	mm (in)	5 (0.2)	5 (0.2)
H	Female thread of shaft		DIN 332-D M8	DIN 332-D M8
J	Connector distance 1 without holding brake	mm (in)	38 (1.5)	38 (1.5)
J	Connector distance 1 with holding brake	mm (in)	35 (1.38)	35 (1.38)
K	Connector distance 2 without holding brake	mm (in)	45 (1.77)	45 (1.77)
K	Connector distance 2 with holding brake	mm (in)	38 (1.5)	38 (1.5)
	Parallel key		DIN 6885-A8x7x40	DIN 6885-A8x7x40

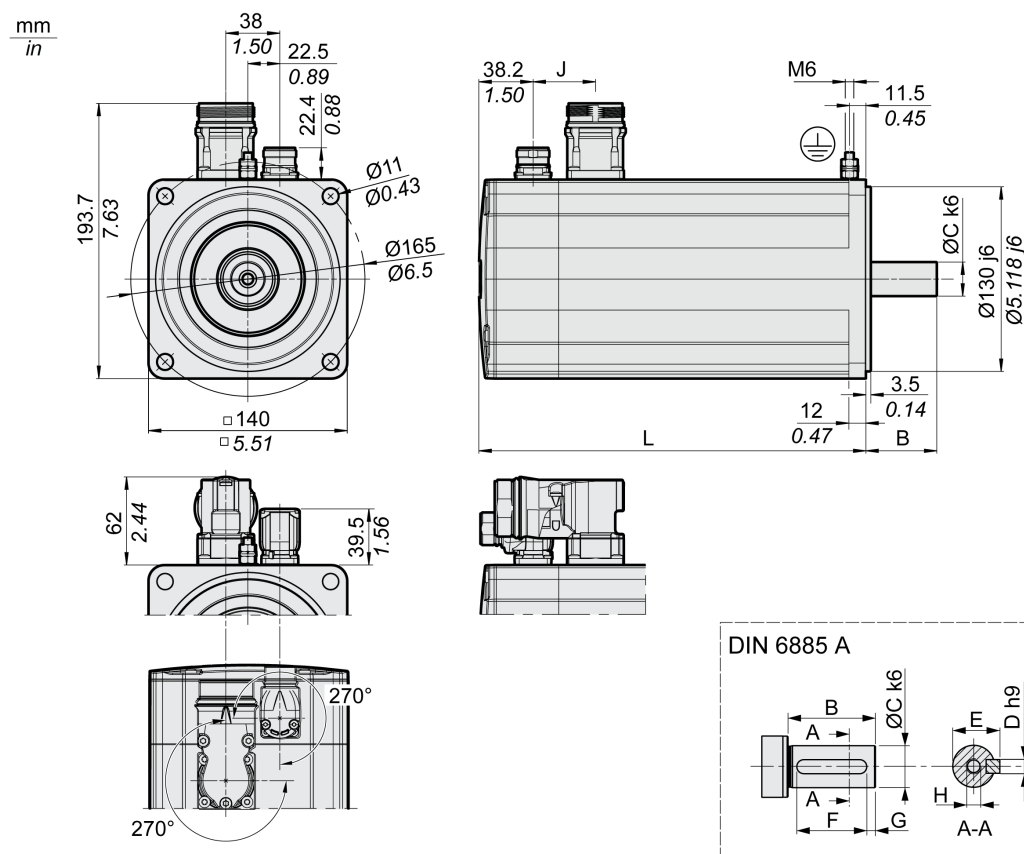

SH3...			1403	1404
L	Length without holding brake	mm (in)	327.5 (12.89)	382.5 (15.06)
L	Length with holding brake	mm (in)	365.5 (14.39)	420.5 (16.56)
B	Shaft length	mm (in)	50 (1.97)	50 (1.97)
C	Shaft diameter	mm (in)	24 (0.94)	24 (0.94)
D	Width of parallel key	mm (in)	8 (0.31)	8 (0.31)
E	Shaft width with parallel key	mm (in)	28 (1.1)	28 (1.1)
F	Length of parallel key	mm (in)	40 (1.57)	40 (1.57)
G	Distance parallel key to shaft end	mm (in)	5 (0.2)	5 (0.2)
H	Female thread of shaft		DIN 332-D M8	DIN 332-D M8
J	Connector distance without holding brake	mm (in)	44 (1.73)	44 (1.73)
J	Connector distance with holding brake	mm (in)	35 (1.38)	35 (1.38)
	Parallel key		DIN 6885-A8x7x40	DIN 6885-A8x7x40

Dimensions SH3140

Hardware version <RS02:

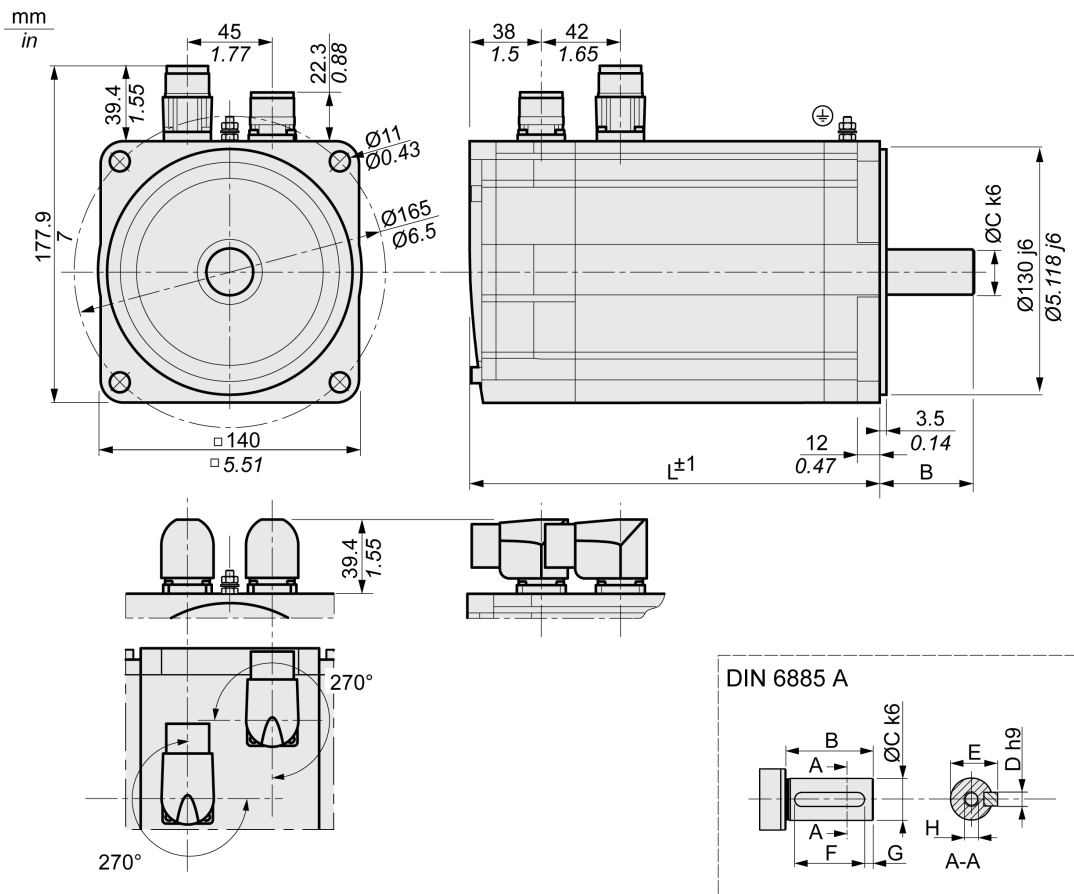

SH3...			1401	1402
L	Length without holding brake	mm (in)	217.5 (8.56)	272.5 (10.73)
L	Length with holding brake	mm (in)	255.5 (10.06)	310.5 (12.22)
B	Shaft length	mm (in)	50 (1.97)	50 (1.97)
C	Shaft diameter	mm (in)	24 (0.94)	24 (0.94)
D	Width of parallel key	mm (in)	8 (0.31)	8 (0.31)
E	Shaft width with parallel key	mm (in)	28 (1.1)	28 (1.1)
F	Length of parallel key	mm (in)	40 (1.57)	40 (1.57)
G	Distance parallel key to shaft end	mm (in)	5 (0.2)	5 (0.2)
H	Female thread of shaft		DIN 332-D M8	DIN 332-D M8
	Parallel key		DIN 6885-A8x7x40	DIN 6885-A8x7x40

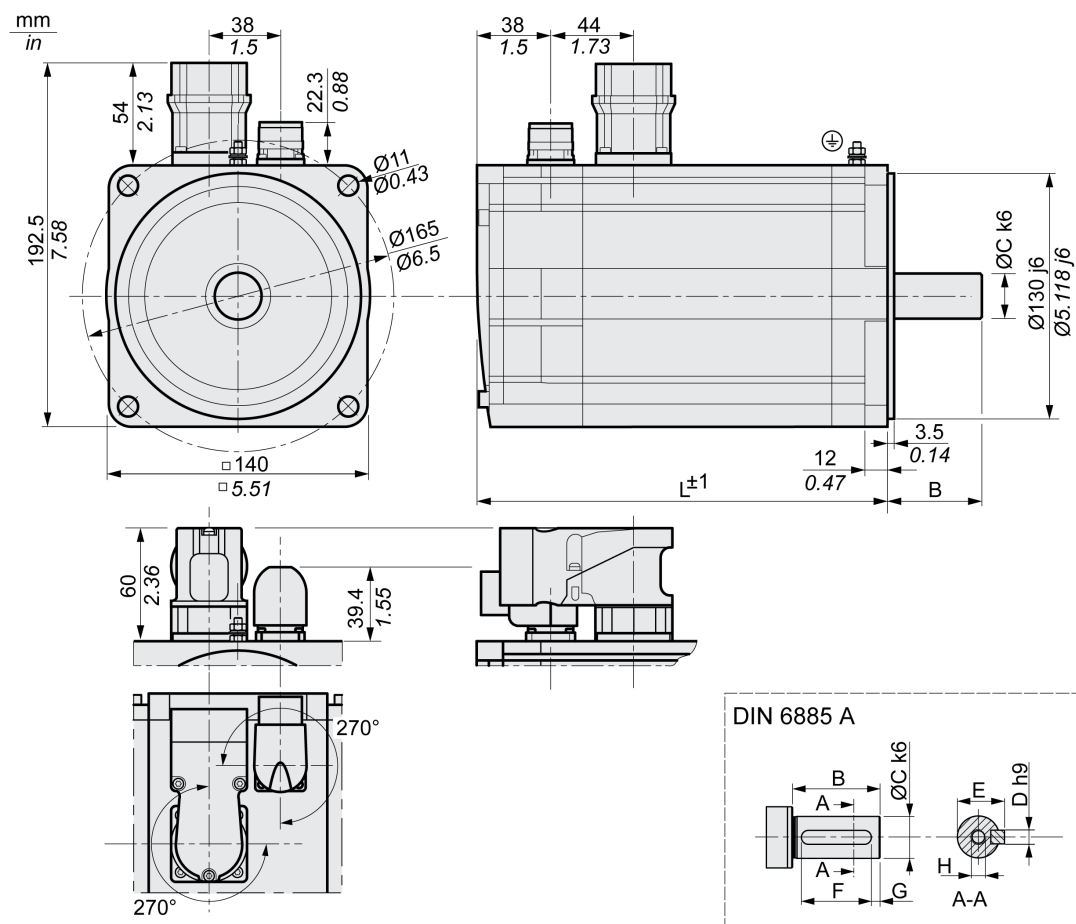

SH3...			1403	1404
L	Length without holding brake	mm (in)	327.5 (12.89)	382.5 (15.06)
L	Length with holding brake	mm (in)	365.5 (14.39)	420.5 (16.56)
B	Shaft length	mm (in)	50 (1.97)	50 (1.97)
C	Shaft diameter	mm (in)	24 (0.94)	24 (0.94)
D	Width of parallel key	mm (in)	8 (0.31)	8 (0.31)
E	Shaft width with parallel key	mm (in)	28 (1.1)	28 (1.1)
F	Length of parallel key	mm (in)	40 (1.57)	40 (1.57)
G	Distance parallel key to shaft end	mm (in)	5 (0.2)	5 (0.2)
H	Female thread of shaft		DIN 332-D M8	DIN 332-D M8
	Parallel key		DIN 6885-A8x7x40	DIN 6885-A8x7x40

Dimensions SH3205

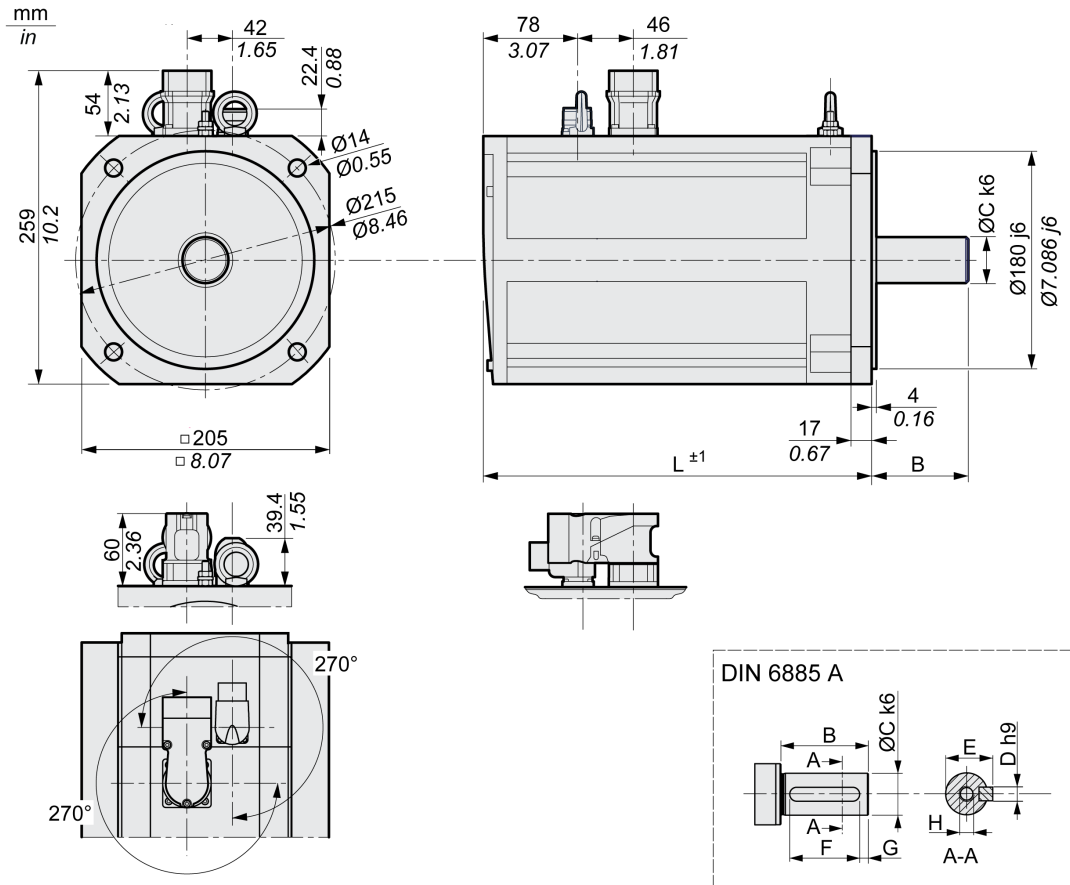

SH3...			2051	2052	2053
L	Length without holding brake	mm (in)	321 (12.64)	405 (15.94)	489 (19.25)
L	Length with holding brake	mm (in)	370.5 (14.59)	454.5 (17.89)	538.5 (21.2)
B	Shaft length	mm (in)	80 (3.15)	80 (3.15)	80 (3.15)
C	Shaft diameter	mm (in)	38 (1.5)	38 (1.5)	38 (1.5)
D	Width of parallel key	mm (in)	10 (0.39)	10 (0.39)	10 (0.39)
E	Shaft width with parallel key	mm (in)	43 (1.69)	43 (1.69)	43 (1.69)
F	Length of parallel key	mm (in)	70 (2.76)	70 (2.76)	70 (2.76)
G	Distance parallel key to shaft end	mm (in)	5 (0.2)	5 (0.2)	5 (0.2)
H	Female thread of shaft		DIN 332-D M12	DIN 332-D M12	DIN 332-D M12
	Parallel key		DIN 6885-A10x8x70	DIN 6885-A10x8x70	DIN 6885-A10x8x70



## Shaft-Specific Data

If the maximum permissible forces at the motor shaft are exceeded, this will result in premature wear of the bearing or shaft breakage.

<b>⚠ WARNING</b>
<b>UNINTENDED EQUIPMENT OPERATION DUE TO MECHANICAL DAMAGE TO THE MOTOR</b>
<ul style="list-style-type: none"> <li>• Do not exceed the maximum permissible axial and radial forces at the motor shaft.</li> <li>• Protect the motor shaft from impact.</li> <li>• Do not exceed the maximum permissible axial force when pressing components onto the motor shaft.</li> </ul>
<b>Failure to follow these instructions can result in death, serious injury, or equipment damage.</b>

### Force for Pressing On

The force applied during pressing on must not exceed the maximum permissible axial force. Applying assembly paste to the shaft and the component to be mounted reduces friction and mechanical impact on the surfaces.

If the shaft has a thread, use it to press on the component to be mounted. This way there is no axial force acting on the rolling bearing.

It is also possible to shrink-fit, clamp or glue the component to be mounted.

The following table shows the maximum permissible axial force  $F_A$  at standstill.

SH3...		040	055	070	100	140	205
Maximum axial force $F_A$ at standstill	N (lbf)	20 (4.5)	40 (9)	80 (18)	160 (36)	300 (65)	740 (165)

### Shaft Load

The following conditions apply:

- The permissible force applied during pressing on must not be exceeded
- Radial and axial limit loads must not be applied simultaneously
- Nominal bearing service life in operating hours at a probability of failure of 10% ( $L_{10h} = 20000$  hours)
- Mean speed of rotation  $n = 4000$  rpm
- Ambient temperature = 40 °C (104 °F)
- Peak torque = Duty types S3 - S8, 10% duty cycle
- Nominal torque = Duty type S1, 100% duty cycle

Shaft load

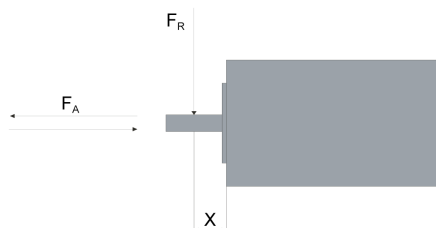

The point of application of the forces depends on the motor size:

SH3...		040	055	0701, 0702	0703	1001, 1002, 1003	1004, 140	205
Value for X	mm (in)	12.5 (0.49)	10 (0.39)	11.5 (0.45)	15 (0.59)	20 (0.76)	25 (0.98)	40 (1.57)

The following tables show the maximum radial shaft load  $F_R$ :

SH3...		0401	0402	0551	0552	0553	0701	0702	0703	1001	1002
1000 rpm	N (lbf)	130 (29)	145 (32)	340 (76)	370 (83)	390 (88)	660 (148)	710 (160)	730 (164)	900 (202)	990 (223)
2000 rpm	N (lbf)	105 (24)	115 (26)	270 (61)	290 (65)	310 (70)	520 (117)	560 (126)	580 (130)	720 (162)	790 (178)
3000 rpm	N (lbf)	90 (20)	100 (22)	240 (54)	260 (58)	270 (61)	460 (103)	490 (110)	510 (115)	630 (142)	690 (155)
4000 rpm	N (lbf)	85 (19)	90 (20)	220 (49)	230 (52)	240 (54)	410 (92)	450 (101)	460 (103)	570 (128)	620 (139)
5000 rpm	N (lbf)	76 (17)	85 (19)	200 (45)	220 (49)	230 (52)	380 (85)	410 (92)	430 (97)	530 (119)	-
6000 rpm	N (lbf)	72 (16)	80 (80)	190 (43)	200 (45)	210 (47)	360 (81)	390 (88)	400 (90)	-	-
7000 rpm	N (lbf)	68 (15)	76 (17)	180 (40)	190 (43)	200 (45)	-	-	-	-	-
8000 rpm	N (lbf)	65 (15)	72 (16)	170 (38)	190 (43)	190 (43)	-	-	-	-	-
9000 rpm	N (lbf)	63 (14)	70 (16)	-	-	-	-	-	-	-	-
10000 rpm	N (lbf)	60 (13)	67 (15)	-	-	-	-	-	-	-	-

SH3...		1003	1004	1401	1402	1403	1404	2051	2052	2053
1000 rpm	N (lbf)	1050 (236)	1070 (241)	1930 (434)	2240 (504)	2420 (544)	2660 (598)	3730 (839)	4200 (944)	4500 (1012)
2000 rpm	N (lbf)	830 (187)	850 (191)	1530 (344)	1780 (400)	1920 (432)	2110 (474)	2960 (665)	3330 (749)	3570 (803)
3000 rpm	N (lbf)	730 (164)	740 (166)	1340 (301)	1550 (348)	1670 (375)	1840 (414)	2580 (580)	2910 (654)	3120 (701)
4000 rpm	N (lbf)	660 (148)	-	-	-	-	-	-	-	-

The following tables show the maximum axial shaft load  $F_A$ :

SH3...		0401	0402	0551	0552	0553	0701	0702	0703	1001	1002
1000 rpm	N (lbf)	26 (6)	29 (7)	68 (15)	74 (17)	78 (18)	132 (30)	142 (32)	146 (33)	180 (40)	198 (45)
2000 rpm	N (lbf)	21 (5)	23 (5)	54 (12)	58 (13)	62 (14)	104 (23)	112 (25)	116 (26)	144 (32)	158 (36)
3000 rpm	N (lbf)	18 (4)	20 (4)	48 (11)	52 (12)	54 (12)	92 (21)	98 (22)	102 (23)	126 (28)	138 (31)
4000 rpm	N (lbf)	17 (4)	18 (4)	44 (10)	46 (10)	48 (11)	82 (18)	90 (20)	92 (21)	114 (26)	124 (28)
5000 rpm	N (lbf)	16 (4)	17 (4)	40 (9)	44 (10)	46 (10)	76 (17)	82 (18)	86 (19)	106 (24)	-
6000 rpm	N (lbf)	15 (3)	16 (4)	38 (9)	40 (9)	42 (9)	72 (16)	78 (18)	80 (18)	-	-
7000 rpm	N (lbf)	14 (3)	15 (3)	36 (8)	38 (9)	40 (9)	-	-	-	-	-
8000 rpm	N (lbf)	13 (3)	14 (3)	34 (8)	38 (9)	38 (9)	-	-	-	-	-
9000 rpm	N (lbf)	12 (3)	13 (3)	-	-	-	-	-	-	-	-
10000 rpm	N (lbf)	11 (2)	12 (3)	-	-	-	-	-	-	-	-

SH3...		1003	1004	1401	1402	1403	1404	2051	2052	2053
1000 rpm	N (lbf)	210 (47)	214 (48)	386 (87)	448 (101)	484 (109)	532 (120)	746 (168)	840 (189)	900 (202)
2000 rpm	N (lbf)	166 (37)	170 (38)	306 (69)	356 (80)	384 (86)	422 (95)	592 (133)	666 (150)	714 (161)
3000 rpm	N (lbf)	146 (33)	148 (33)	268 (60)	310 (70)	334 (75)	368 (83)	516 (116)	582 (131)	624 (140)
4000 rpm	N (lbf)	132 (30)	-	-	-	-	-	-	-	-

Motor-Specific Data

SH3040

SH3...		0401	0402
Winding		P	P
<b>Technical data - general<sup>1)</sup></b>			
Continuous stall torque $M_0^{2)}$	Nm	0.21	0.39
Peak torque $M_{max}$	Nm	0.75	1.50
Number of pole pairs		5	
<b>With supply voltage <math>U_n = 115</math> Vac</b>			
Nominal speed of rotation $n_N$	rpm	2000	2000
Nominal torque $M_N$	Nm	0.20	0.38
Nominal current $I_N$	$A_{rms}$	1.03	1.45
Nominal power $P_N$	kW	0.042	0.078
<b>With supply voltage <math>U_n = 230</math> Vac</b>			
Nominal speed of rotation $n_N$	rpm	4000	4000
Nominal torque $M_N$	Nm	0.19	0.37
Nominal current $I_N$	$A_{rms}$	1.01	1.42
Nominal power $P_N$	kW	0.080	0.152
<b>With supply voltage <math>U_n = 400</math> Vac</b>			
Nominal speed of rotation $n_N$	rpm	9000	9000
Nominal torque $M_N$	Nm	0.18	0.31
Nominal current $I_N$	$A_{rms}$	1.02	1.27
Nominal power $P_N$	kW	0.170	0.292
<b>With supply voltage <math>U_n = 480</math> Vac</b>			
Nominal speed of rotation $n_N$	rpm	9000	9000
Nominal torque $M_N$	Nm	0.175	0.290
Nominal current $I_N$	$A_{rms}$	1.04	1.26
Nominal power $P_N$	kW	0.165	0.275
<p>1) Conditions for performance data: Mounted to aluminum plate 185 mm (7.28 in) x 185 mm (7.28 in) x 8 mm (0.31 in).</p> <p>2) <math>M_0</math> = Continuous stall torque at 20 rpm and 100% duty cycle; at speeds of rotation less than 20 rpm the continuous stall torque is reduced to 87%.</p>			

SH3...		0401	0402
Winding		P	P
<b>Technical data - electrical</b>			
Maximum winding voltage $U_{max}$	Vac	480	480
Maximum winding voltage $U_{max}$	Vdc	680	680
Maximum voltage to ground	Vac	280	280
Maximum current $I_{max}$	$A_{rms}$	4.5	7.2
Continuous stall current $I_0$	$A_{rms}$	1.12	1.50
Voltage constant $k_E U-v^{1)}$	$V_{rms}$	13.6	18.0
Torque constant $k_t$	Nm/A	0.190	0.260
1) RMS value at 1000 rpm and 20°C (68 °F).			

SH3...		0401	0402
Winding		P	P
Winding resistance $R_{20U-V}$	$\Omega$	17.2	11.6
Winding inductance $L_{qU-V}$	mH	14.6	12.8
Winding inductance $L_{dU-V}$	mH	13.2	11.6
Technical data - mechanical			
Maximum permissible speed of rotation $n_{max}$	rpm	10000	
Rotor inertia without holding brake $J_M$	kgcm <sup>2</sup>	0.0232	0.0419
Rotor inertia with holding brake $J_M$	kgcm <sup>2</sup>	0.0400	0.0588
Mass without holding brake m	kg	0.43	0.57
Mass with holding brake m	kg	0.58	0.72
Technical data - thermal			
Thermal time constant $t_{th}$	min	8	10
1) RMS value at 1000 rpm and 20°C (68 °F).			

## SH3055

SH3...		0551	0552	0553
Winding		P	P	P
Technical data - general <sup>1)</sup>				
Continuous stall torque $M_0^{2)}$	Nm	0.5	0.8	1.2
Peak torque $M_{max}$	Nm	1.5	2.5	3.5
Number of pole pairs		3		
With supply voltage $U_n = 115$ Vac				
Nominal speed of rotation $n_N$	rpm	2000	2000	2000
Nominal torque $M_N$	Nm	0.50	0.77	1.13
Nominal current $I_N$	$A_{rms}$	0.70	1.18	1.60
Nominal power $P_N$	kW	0.10	0.16	0.24
With supply voltage $U_n = 230$ Vac				
Nominal speed of rotation $n_N$	rpm	8000	4000	4000
Nominal torque $M_N$	Nm	0.50	0.75	1.10
Nominal current $I_N$	$A_{rms}$	0.68	1.15	1.52
Nominal power $P_N$	kW	0.21	0.31	0.46
With supply voltage $U_n = 400$ Vac				
Nominal speed of rotation $n_N$	rpm	8000	8000	8000
Nominal torque $M_N$	Nm	0.48	0.72	1.05
Nominal current $I_N$	$A_{rms}$	0.62	1.10	1.35
Nominal power $P_N$	kW	0.40	0.60	0.88
With supply voltage $U_n = 480$ Vac				
Nominal speed of rotation $n_N$	rpm	9000	9000	9000
Nominal torque $M_N$	Nm	0.47	0.71	1.03
Nominal current $I_N$	$A_{rms}$	0.60	1.09	1.31
Nominal power $P_N$	kW	0.44	0.67	0.97
1) Conditions for performance data: Mounted to steel plate 175 mm (6.89 in) x 175 mm (6.89 in) x 10 mm (0.39 in).				
2) $M_0$ = Continuous stall torque at 20 rpm and 100% duty cycle; at speeds of rotation less than 20 rpm the continuous stall torque is reduced to 87%.				

SH3...		0551	0552	0553
Winding		P	P	P
<b>Technical data - electrical</b>				
Maximum winding voltage $U_{\max}$	Vac	480	480	480
Maximum winding voltage $U_{\max}$	Vdc	680	680	680
Maximum voltage to ground	Vac	280	280	280
Maximum current $I_{\max}$	$A_{\text{rms}}$	2.90	4.80	6.50
Continuous stall current $I_0$	$A_{\text{rms}}$	0.73	1.20	1.70
Voltage constant $k_E u \cdot v^{1)}$	$V_{\text{rms}}$	40.00	40.00	41.00
Torque constant $k_t$	Nm/A	0.68	0.70	0.70
Winding resistance $R_{20} u \cdot v$	$\Omega$	41.80	17.40	10.40
Winding inductance $L_q u \cdot v$	mH	74.3	36.40	26.00
Winding inductance $L_d u \cdot v$	mH	68.84	34.28	23.96
<b>Technical data - mechanical - with hardware version <math>\geq</math>RS02</b>				
Maximum permissible speed of rotation $n_{\max}$	rpm	9000		
Rotor inertia without holding brake $J_M$	$\text{kgcm}^2$	0.057	0.093	0.130
Rotor inertia with holding brake $J_M$	$\text{kgcm}^2$	0.079	0.115	0.152
Mass without holding brake m	kg	1.20	1.50	1.70
Mass with holding brake m	kg	1.30	1.60	1.80
<b>Technical data - mechanical - with hardware version <math>&lt;</math>RS02</b>				
Maximum permissible speed of rotation $n_{\max}$	rpm	9000		
Rotor inertia without holding brake $J_M$	$\text{kgcm}^2$	0.057	0.093	0.130
Rotor inertia with holding brake $J_M$	$\text{kgcm}^2$	0.080	0.117	0.115
Mass without holding brake m	kg	1.20	1.30	1.80
Mass with holding brake m	kg	1.30	1.60	2.10
<b>Technical data - thermal</b>				
Thermal time constant $t_{th}$	min	21	26	33
Response threshold temperature sensor (PTC) $T_{TK}$	$^{\circ}\text{C}$ $(^{\circ}\text{F})$	130 (266)		
1) RMS value at 1000 rpm and 20°C (68 °F).				

## SH3070

SH3...		0701	0702		0703	
Winding		P	M	P	M	P
<b>Technical data - general<sup>1)</sup></b>						
Continuous stall torque $M_0^{2)}$	Nm	1.4	2.2		3.1	
Peak torque $M_{max}$	Nm	3.5	7.6		11.3	
Number of pole pairs		3				
<b>With supply voltage <math>U_n = 115</math> Vac</b>						
Nominal speed of rotation $n_N$	rpm	1500	750	1500	750	1500
Nominal torque $M_N$	Nm	1.40	2.20	2.15	3.05	2.95
Nominal current $I_N$	$A_{rms}$	1.76	1.50	2.90	2.10	3.90
Nominal power $P_N$	kW	0.22	0.17	0.34	0.24	0.46
<b>With supply voltage <math>U_n = 230</math> Vac</b>						
Nominal speed of rotation $n_N$	rpm	3000	1500	3000	1500	3000
Nominal torque $M_N$	Nm	1.40	2.15	2.10	2.95	2.80
Nominal current $I_N$	$A_{rms}$	1.72	1.50	2.80	2.00	3.70
Nominal power $P_N$	kW	0.44	0.34	0.66	0.46	0.88
<b>With supply voltage <math>U_n = 400</math> Vac</b>						
Nominal speed of rotation $n_N$	rpm	6000	3000	6000	3000	6000
Nominal torque $M_N$	Nm	1.30	2.10	1.90	2.80	2.30
Nominal current $I_N$	$A_{rms}$	1.60	1.50	2.60	1.90	3.00
Nominal power $P_N$	kW	0.82	0.66	1.19	0.88	1.45
<b>With supply voltage <math>U_n = 480</math> Vac</b>						
Nominal speed of rotation $n_N$	rpm	7200	3600	7200	3600	7200
Nominal torque $M_N$	Nm	1.26	2.07	1.80	2.72	2.05
Nominal current $I_N$	$A_{rms}$	1.54	1.50	2.50	1.85	2.65
Nominal power $P_N$	kW	0.95	0.78	1.36	1.03	1.55
1) Conditions for performance data: Mounted to steel plate (2.5 x flange dimension) <sup>2</sup> area, 10 mm (0.39 in) thickness, centered hole. 2) $M_0$ = Continuous stall torque at 20 rpm and 100% duty cycle; at speeds of rotation less than 20 rpm the continuous stall torque is reduced to 87%.						

SH3...		0701	0702		0703	
Winding		P	M	P	M	P
<b>Technical data - electrical</b>						
Maximum winding voltage $U_{max}$	Vac	480	480	480	480	480
Maximum winding voltage $U_{max}$	Vdc	680	680	680	680	680
Maximum voltage to ground	Vac	280	280	280	280	280
Maximum current $I_{max}$	$A_{rms}$	5.70	6.00	11.80	8.70	17.00
Continuous stall current $I_0$	$A_{rms}$	1.80	1.50	2.90	2.10	4.10
Voltage constant $k_E u-v^{1)}$	$V_{rms}$	46.00	95.90	48.00	95.00	49.00
Torque constant $k_t$	Nm/A	0.80	1.47	0.77	1.48	0.78
Winding resistance $R_{20} u-v$	$\Omega$	10.40	16.40	4.20	10.70	2.70
Winding inductance $L_q u-v$	mH	42.60	83.10	21.30	55.30	14.60
Winding inductance $L_d u-v$	mH	35.30	65.20	16.70	43.10	11.40
1) RMS value at 1000 rpm and 20 °C (68 °F).						

SH3...		0701		0702		0703	
Winding		P	M	P	M	P	
<b>Technical data - mechanical - with hardware version ≥RS02</b>							
Maximum permissible speed of rotation $n_{max}$	rpm	8000					
Rotor inertia without holding brake $J_M$	kgcm <sup>2</sup>	0.205	0.351		0.503		
Rotor inertia with holding brake $J_M$	kgcm <sup>2</sup>	0.318	0.464		0.616		
Mass without holding brake m	kg	1.90	2.80		3.40		
Mass with holding brake m	kg	2.10	3.00		3.50		
<b>Technical data - mechanical - with hardware version &lt;RS02</b>							
Maximum permissible speed of rotation $n_{max}$	rpm	8000					
Rotor inertia without holding brake $J_M$	kgcm <sup>2</sup>	0.205	0.351		0.503		
Rotor inertia with holding brake $J_M$	kgcm <sup>2</sup>	0.322	0.482		0.807		
Mass without holding brake m	kg	2.20	2.90		3.50		
Mass with holding brake m	kg	2.40	3.00		3.50		
<b>Technical data - thermal</b>							
Thermal time constant $t_{th}$	min	35	38		51		
Response threshold temperature sensor (PTC) $T_{TK}$	°C (°F)	130 (266)					
1) RMS value at 1000 rpm and 20 °C (68 °F).							

**SH3100**

SH3...		1001		1002	
Winding		M	P	M	P
<b>Technical data - general<sup>1)</sup></b>					
Continuous stall torque $M_0^{2)}$	Nm	3.3		5.8	
Peak torque $M_{max}$	Nm	9.6		18.3	
Number of pole pairs		4			
<b>With supply voltage <math>U_n = 115</math> Vac</b>					
Nominal speed of rotation $n_N$	rpm	625	1250	500	1000
Nominal torque $M_N$	Nm	3.20	3.15	5.70	5.50
Nominal current $I_N$	$A_{rms}$	1.75	3.50	2.45	4.55
Nominal power $P_N$	kW	0.21	0.41	0.30	0.58
<b>With supply voltage <math>U_n = 230</math> Vac</b>					
Nominal speed of rotation $n_N$	rpm	1250	2500	1000	2000
Nominal torque $M_N$	Nm	3.15	3.00	5.50	5.20
Nominal current $I_N$	$A_{rms}$	1.70	3.20	2.40	4.30
Nominal power $P_N$	kW	0.41	0.79	0.58	1.09
<b>With supply voltage <math>U_n = 400</math> Vac</b>					
Nominal speed of rotation $n_N$	rpm	2500	5000	2000	4000
Nominal torque $M_N$	Nm	3.00	2.70	5.20	4.60
Nominal current $I_N$	$A_{rms}$	1.60	2.80	2.30	3.80
Nominal power $P_N$	kW	0.79	1.41	1.09	1.93
1) Conditions for performance data: Mounted to steel plate (2.5 x flange dimension) <sup>2)</sup> area, 10 mm (0.39 in) thickness, centered hole.					
2) $M_0$ = Continuous stall torque at 20 rpm and 100% duty cycle; at speeds of rotation less than 20 rpm the continuous stall torque is reduced to 87%.					



SH3...	1001		1002		
Winding	M	P	M	P	
<b>Technical data - general<sup>1)</sup></b>					
<b>With supply voltage <math>U_n = 480</math> Vac</b>					
Nominal speed of rotation $n_N$	rpm	3000	6000	2400	4800
Nominal torque $M_N$	Nm	2.95	2.60	5.10	4.40
Nominal current $I_N$	$A_{rms}$	1.60	2.60	2.25	3.60
Nominal power $P_N$	kW	0.93	1.63	1.28	2.21
1) Conditions for performance data: Mounted to steel plate (2.5 x flange dimension) <sup>2</sup> area, 10 mm (0.39 in) thickness, centered hole. 2) $M_0$ = Continuous stall torque at 20 rpm and 100% duty cycle; at speeds of rotation less than 20 rpm the continuous stall torque is reduced to 87%.					

SH3...	1001		1002		
Winding	M	P	M	P	
<b>Technical data - electrical</b>					
Maximum winding voltage $U_{max}$	Vac	480	480	480	480
Maximum winding voltage $U_{max}$	Vdc	680	680	680	680
Maximum voltage to ground	Vac	280	280	280	280
Maximum current $I_{max}$	$A_{rms}$	6.30	12.00	9.00	17.10
Continuous stall current $I_0$	$A_{rms}$	1.80	3.50	2.50	4.80
Voltage constant $k_{E-u-v^{1)}$	$V_{rms}$	115.00	60.00	146.00	77.00
Torque constant $k_t$	Nm/A	1.83	0.89	2.32	1.21
Winding resistance $R_{20u-v}$	$\Omega$	13.90	3.80	8.60	2.40
Winding inductance $L_{q-u-v}$	mH	69.40	19.00	48.60	13.50
Winding inductance $L_{d-u-v}$	mH	59.50	16.30	43.20	12.00
<b>Technical data - mechanical - with hardware version <math>\geq</math>RS02</b>					
Maximum permissible speed of rotation $n_{max}$	rpm	6000			
Rotor inertia without holding brake $J_M$	kgcm <sup>2</sup>	1.100		1.909	
Rotor inertia with holding brake $J_M$	kgcm <sup>2</sup>	1.613		2.422	
Mass without holding brake m	kg	4.40		6.00	
Mass with holding brake m	kg	4.90		6.50	
<b>Technical data - mechanical - with hardware version <math>&lt;</math>RS02</b>					
Maximum permissible speed of rotation $n_{max}$	rpm	6000			
Rotor inertia without holding brake $J_M$	kgcm <sup>2</sup>	1.100		1.909	
Rotor inertia with holding brake $J_M$	kgcm <sup>2</sup>	2.018		2.928	
Mass without holding brake m	kg	4.30		5.90	
Mass with holding brake m	kg	5.00		6.60	
<b>Technical data - thermal</b>					
Thermal time constant $t_{th}$	min	44		48	
Response threshold temperature sensor (PTC) $T_{TK}$	$^{\circ}C$ ( $^{\circ}F$ )	130 (266)			
1) RMS value at 1000 rpm and 20 $^{\circ}C$ (68 $^{\circ}F$ ).					

SH3...	1003			1004
Winding	M	P	-	P
<b>Technical data - general<sup>1)</sup></b>				
Continuous stall torque $M_0^{2)}$	Nm	8		10
Peak torque $M_{max}$	Nm	28.3		40.5
Number of pole pairs		4		
<b>With supply voltage <math>U_n = 115</math> Vac</b>				
Nominal speed of rotation $n_N$	rpm	500	1000	- 750
Nominal torque $M_N$	Nm	7.80	7.50	- 9.90
Nominal current $I_N$	$A_{rms}$	3.34	6.30	- 6.25
Nominal power $P_N$	kW	0.41	0.79	- 0.78
<b>With supply voltage <math>U_n = 230</math> Vac</b>				
Nominal speed of rotation $n_N$	rpm	1000	2000	- 1500
Nominal torque $M_N$	Nm	7.50	7.00	- 9.50
Nominal current $I_N$	$A_{rms}$	3.27	5.90	- 6.10
Nominal power $P_N$	kW	0.79	1.47	- 1.49
<b>With supply voltage <math>U_n = 400</math> Vac</b>				
Nominal speed of rotation $n_N$	rpm	2000	4000	- 3000
Nominal torque $M_N$	Nm	7.00	5.70	- 7.90
Nominal current $I_N$	$A_{rms}$	3.10	4.90	- 5.30
Nominal power $P_N$	kW	1.47	2.39	- 2.48
<b>With supply voltage <math>U_n = 480</math> Vac</b>				
Nominal speed of rotation $n_N$	rpm	2400	4800	- 3600
Nominal torque $M_N$	Nm	6.76	5.10	- 6.90
Nominal current $I_N$	$A_{rms}$	3.00	4.40	- 4.80
Nominal power $P_N$	kW	1.70	2.56	- 2.60
1) Conditions for performance data: Mounted to steel plate (2.5 x flange dimension) <sup>2)</sup> area, 10 mm (0.39 in) thickness, centered hole. 2) $M_0$ = Continuous stall torque at 20 rpm and 100% duty cycle; at speeds of rotation less than 20 rpm the continuous stall torque is reduced to 87%.				

SH3...	1003			1004
Winding	M	P	P	
<b>Technical data - electrical</b>				
Maximum winding voltage $U_{max}$	Vac	480	480	480
Maximum winding voltage $U_{max}$	Vdc	680	680	680
Maximum voltage to ground	Vac	280	280	280
Maximum current $I_{max}$	$A_{rms}$	14.70	28.30	32.30
Continuous stall current $I_0$	$A_{rms}$	3.40	6.60	6.20
Voltage constant $k_E u-v^{1)}$	$V_{rms}$	148.00	77.00	103.00
Torque constant $k_t$	Nm/A	2.35	1.22	1.62
Winding resistance $R_{20u-v}$	$\Omega$	5.30	1.43	1.81
Winding inductance $L_{qu-v}$	mH	34.80	9.40	13.00
Winding inductance $L_{du-v}$	mH	30.00	8.10	10.70
1) RMS value at 1000 rpm and 20 °C (68 °F).				

SH3...	1003		1004
Winding	M	P	P
<b>Technical data - mechanical - with hardware version ≥RS02</b>			
Maximum permissible speed of rotation $n_{max}$	rpm	6000	
Rotor inertia without holding brake $J_M$	kgcm <sup>2</sup>	2.718	3.613
Rotor inertia with holding brake $J_M$	kgcm <sup>2</sup>	3.521	4.416
Mass without holding brake m	kg	7.70	9.40
Mass with holding brake m	kg	8.40	10.30
<b>Technical data - mechanical - with hardware version &lt;RS02</b>			
Maximum permissible speed of rotation $n_{max}$	rpm	6000	
Rotor inertia without holding brake $J_M$	kgcm <sup>2</sup>	2.718	3.613
Rotor inertia with holding brake $J_M$	kgcm <sup>2</sup>	3.838	5.245
Mass without holding brake m	kg	7.50	9.10
Mass with holding brake m	kg	8.20	9.80
<b>Technical data - thermal</b>			
Thermal time constant $t_{th}$	min	56	58
Response threshold temperature sensor (PTC) $T_{TK}$	°C (°F)	130 (266)	
1) RMS value at 1000 rpm and 20 °C (68 °F).			

**SH3140**

SH3...	1401		1402	1403	1404
Winding	M	P	P	P	P
<b>Technical data - general<sup>1)</sup></b>					
Continuous stall torque $M_0^{2)}$	Nm	11.1	19.5	27.8	33.4
Peak torque $M_{max}$	Nm	27	60.1	90.2	131.9
Number of pole pairs		5			
<b>With supply voltage <math>U_n = 115</math> Vac</b>					
Nominal speed of rotation $n_N$	rpm	375	750	750	750
Nominal torque $M_N$	Nm	11.00	10.95	18.60	24.70
Nominal current $I_N$	A <sub>rms</sub>	4.00	7.80	12.80	15.90
Nominal power $P_N$	kW	0.43	0.86	1.46	2.37
<b>With supply voltage <math>U_n = 230</math> Vac</b>					
Nominal speed of rotation $n_N$	rpm	750	1500	1500	1500
Nominal torque $M_N$	Nm	10.95	10.60	17.10	21.20
Nominal current $I_N$	A <sub>rms</sub>	4.00	7.60	12.00	13.90
Nominal power $P_N$	kW	0.86	1.67	2.69	3.33
<b>With supply voltage <math>U_n = 400</math> Vac</b>					
Nominal speed of rotation $n_N$	rpm	1500	3000	3000	3000
Nominal torque $M_N$	Nm	10.60	9.20	12.30	12.90
Nominal current $I_N$	A <sub>rms</sub>	4.00	6.80	8.90	8.70
Nominal power $P_N$	kW	1.67	2.89	3.86	4.05
1) Conditions for performance data: Mounted to steel plate (2.5 x flange dimension) <sup>2)</sup> area, 10 mm (0.39 in) thickness, centered hole.					
2) $M_0$ = Continuous stall torque at 20 rpm and 100% duty cycle; at speeds of rotation less than 20 rpm the continuous stall torque is reduced to 87%.					

SH3...	1401		1402	1403	1404	
Winding	M	P	P	P	P	
<b>Technical data - general<sup>1)</sup></b>						
<b>With supply voltage <math>U_n = 480</math> Vac</b>						
Nominal speed of rotation $n_N$	rpm	1800	3600	3600	3600	
Nominal torque $M_N$	Nm	10.40	8.40	9.70	9.10	11.10
Nominal current $I_N$	$A_{rms}$	4.00	6.30	7.10	6.20	7.70
Nominal power $P_N$	kW	1.96	3.17	3.66	3.43	4.19
1) Conditions for performance data: Mounted to steel plate (2.5 x flange dimension) <sup>2</sup> area, 10 mm (0.39 in) thickness, centered hole. 2) $M_0$ = Continuous stall torque at 20 rpm and 100% duty cycle; at speeds of rotation less than 20 rpm the continuous stall torque is reduced to 87%.						

SH3...	1401		1402	1403	1404	
Winding	M	P	P	P	P	
<b>Technical data - electrical</b>						
Maximum winding voltage $U_{max}$	Vac	480	480	480	480	
Maximum winding voltage $U_{max}$	Vdc	680	680	680	680	
Maximum voltage to ground	Vac	280	280	280	280	
Maximum current $I_{max}$	$A_{rms}$	10.80	20.80	44.10	61.00	95.60
Continuous stall current $I_0$	$A_{rms}$	4.00	7.80	13.20	17.60	21.30
Voltage constant $k_E u-v^1)$	$V_{rms}$	193.00	100.00	101.00	105.00	104.00
Torque constant $k_t$	Nm/A	2.78	1.43	1.47	1.58	1.57
Winding resistance $R_{20u-v}$	$\Omega$	5.30	1.41	0.60	0.40	0.28
Winding inductance $L_{qu-v}$	mH	60.90	16.30	7.70	5.30	4.10
Winding inductance $L_{d-u-v}$	mH	55.30	14.84	7.05	4.84	3.69
<b>Technical data - mechanical - with hardware version <math>\geq</math>RS02</b>						
Maximum permissible speed of rotation $n_{max}$	rpm	4000				
Rotor inertia without holding brake $J_M$	kgcm <sup>2</sup>	6.941		12.162	17.383	22.604
Rotor inertia with holding brake $J_M$	kgcm <sup>2</sup>	8.542		14.824	21.559	26.794
Mass without holding brake m	kg	11.50		16.50	21.90	27.00
Mass with holding brake m	kg	12.90		18.10	24.00	29.30
<b>Technical data - mechanical - with hardware version <math>&lt;</math>RS02</b>						
Maximum permissible speed of rotation $n_{max}$	rpm	4000				
Rotor inertia without holding brake $J_M$	kgcm <sup>2</sup>	6.941		12.162	17.94	23.70
Rotor inertia with holding brake $J_M$	kgcm <sup>2</sup>	9.210		14.480	21.559	26.794
Mass without holding brake m	kg	11.20		16.10	21.30	26.30
Mass with holding brake m	kg	12.60		17.40	23.20	28.40
<b>Technical data - thermal</b>						
Thermal time constant $t_{th}$	min	64		74	79	83
Response threshold temperature sensor (PTC) $T_{TK}$	$^{\circ}C$ $(^{\circ}F)$	130 (266)				
1) RMS value at 1000 rpm and 20 $^{\circ}C$ (68 $^{\circ}F$ ).						

## SH3205

SH3...		2051	2052	2053
<b>Winding</b>		<b>P</b>	<b>P</b>	<b>P</b>
<b>Technical data - general<sup>1)</sup></b>				
Continuous stall torque $M_0^{2)}$	Nm	36.90	64.90	94.40
Peak torque $M_{max}$	Nm	110	220	330
Number of pole pairs		5		
<b>With supply voltage <math>U_n = 115</math> Vac</b>				
Nominal speed of rotation $n_N$	rpm	750	500	500
Nominal torque $M_N$	Nm	31.90	61.60	84.90
Nominal current $I_N$	$A_{rms}$	18.80	25.40	30.80
Nominal power $P_N$	kW	2.51	3.23	4.45
<b>With supply voltage <math>U_n = 230</math> Vac</b>				
Nominal speed of rotation $n_N$	rpm	1500	1000	1000
Nominal torque $M_N$	Nm	27.00	56.00	74.40
Nominal current $I_N$	$A_{rms}$	16.50	24.00	27.90
Nominal power $P_N$	kW	4.24	5.86	7.79
<b>With supply voltage <math>U_n = 400</math> Vac</b>				
Nominal speed of rotation $n_N$	rpm	3000	2000	2000
Nominal torque $M_N$	Nm	17.50	38.10	50.70
Nominal current $I_N$	$A_{rms}$	11.50	17.80	20.40
Nominal power $P_N$	kW	5.50	7.98	10.62
<b>With supply voltage <math>U_n = 480</math> Vac</b>				
Nominal speed of rotation $n_N$	rpm	3600	2400	2400
Nominal torque $M_N$	Nm	13.80	28.40	40.20
Nominal current $I_N$	$A_{rms}$	9.40	13.80	16.70
Nominal power $P_N$	kW	5.20	7.14	10.10
<p>1) Conditions for performance data: Mounted to steel plate (2.5 x flange dimension)<sup>2</sup> area, 10 mm (0.39 in) thickness, centered hole.</p> <p>2) <math>M_0</math> = Continuous stall torque at 20 rpm and 100% duty cycle; at speeds of rotation less than 20 rpm the continuous stall torque is reduced to 87%.</p>				

SH3...		2051	2052	2053
<b>Winding</b>		<b>P</b>	<b>P</b>	<b>P</b>
<b>Technical data - electrical</b>				
Maximum winding voltage $U_{max}$	Vac	480	480	480
Maximum winding voltage $U_{max}$	Vdc	680	680	680
Maximum voltage to ground	Vac	280	280	280
Maximum current $I_{max}$	$A_{rms}$	87.20	96.80	136.10
Continuous stall current $I_0$	$A_{rms}$	21.00	25.70	33.20
Voltage constant $k_E u-v^1)$	$V_{rms}$	104.00	161.00	172.00
Torque constant $k_t$	Nm/A	1.60	2.58	2.76
Winding resistance $R_{20} u-v$	$\Omega$	0.30	0.30	0.20
Winding inductance $L_q u-v$	mH	5.90	5.60	4.30
Winding inductance $L_d u-v$	mH	5.60	5.20	4.00
1) RMS value at 1000 rpm and 20 °C (68 °F).				

SH3...		2051	2052	2053
<b>Winding</b>		<b>P</b>	<b>P</b>	<b>P</b>
<b>Technical data - mechanical</b> - with hardware version <RS02				
Maximum permissible speed of rotation $n_{max}$	rpm	3800		
Rotor inertia without holding brake $J_M$	kgcm <sup>2</sup>	71.40	129	190
Rotor inertia with holding brake $J_M$	kgcm <sup>2</sup>	87.40	145	206
Mass without holding brake m	kg	35.00	50.00	67.00
Mass with holding brake m	kg	38.60	53.60	70.60
<b>Technical data - thermal</b>				
Thermal time constant $n_{max}$	min	73	88	101
Response threshold temperature sensor (PTC) $J_M$	°C (°F)	130 (266)		
<b>1) RMS value at 1000 rpm and 20 °C (68 °F).</b>				

## Encoder

The motors are equipped with a SinCos encoder. The drive can access the electronic nameplate via the Hiperface interface for commissioning.

The signals meet the PELV requirements.

### SKS36 Singleturn

This motor encoder measures an absolute value within one revolution at start-up and continues to count incrementally from this point.

Characteristic	Value
Resolution in increments	Depending on evaluation
Resolution per revolution	128 sin/cos periods
Measuring range absolute	1 revolution
Accuracy of the digital absolute value <sup>1)</sup>	±0.0889°
Accuracy of the incremental position	±0.0222°
Signal shape	Sinusoidal
Supply voltage	7 ... 12 Vdc
Maximum supply current	60 mA (without load)
Maximum angular acceleration	200000 rad/s <sup>2</sup>
<b>1)</b> Depending on the evaluation through the drive, the accuracy may be increased by including the incremental position in the calculation of the absolute value. In this case, the accuracy corresponds to the incremental position.	

### SKM36 Multiturn

This motor encoder measures an absolute value within 4096 revolutions at start-up and continues to count incrementally from this point.

Characteristic	Value
Resolution in increments	Depending on evaluation
Resolution per revolution	128 sin/cos periods
Measuring range absolute	4096 revolutions
Accuracy of the digital absolute value <sup>1)</sup>	±0.0889°
Accuracy of the incremental position	±0.0222°
Signal shape	Sinusoidal
Supply voltage	7 ... 12 Vdc
Maximum supply current	60 mA (without load)
Maximum angular acceleration	200000 rad/s <sup>2</sup>
<b>1)</b> Depending on the evaluation through the drive, the accuracy may be increased by including the incremental position in the calculation of the absolute value. In this case, the accuracy corresponds to the incremental position.	

### SEK37 Singleturn

This motor encoder measures an absolute value within one revolution at start-up and continues to count incrementally from this point.

Characteristic	Value
Resolution in increments	Depending on evaluation
Resolution per revolution	16 sin/cos periods
Measuring range absolute	1 revolution
Accuracy of position	$\pm 0.08^\circ$
Signal shape	Sinusoidal
Supply voltage	7 ... 12 Vdc
Maximum supply current	50 mA (without load)

### SEL37 Multiturn

This motor encoder measures an absolute value within 4096 revolutions at start-up and continues to count incrementally from this point.

Characteristic	Value
Resolution in increments	Depending on evaluation
Resolution per revolution	16 sin/cos periods
Measuring range absolute	4096 revolutions
Accuracy of position	$\pm 0.08^\circ$
Signal shape	Sinusoidal
Supply voltage	7 ... 12 Vdc
Maximum supply current	50 mA (without load)



## Holding Brake

 Hardware version  $\geq$ RS02:

SH3...		040	055	070	1001, 1002	1003, 1004	1401	1402	1403, 1404	205
Holding torque <sup>1)</sup>	Nm (lb•in)	0.4 (3.54)	0.8 (7.08)	3.0 (26.6)	5.5 (48.7)	10 (88.5)	18 (159)	23 (204)	33 (292)	80 (708)
Opening time	ms	24	12	80	70	90	100	100	200	200
Coupling time	ms	13	6	17	30	25	50	40	60	50
Nominal voltage	Vdc	24 +15% -15%	24 +6% -10%	24 +5% -15%	24 +5% -15%	24 +5% -15%	24 +5% -15%	24 +5% -15%	24 +5% -15%	24 +6% -10%
Nominal power (electrical pull-in power)	W	5.8	10	7	12	18	18	19	22.5	40
Maximum speed of rotation during braking of moving loads	rpm	3000	3000	3000	3000	3000	3000	3000	3000	3000
Maximum number of decelerations during braking of moving loads and 3000 rpm		500	500	500	500	500	500	500	500	500
Maximum number of decelerations during braking of moving loads per hour (at even distribution)		20	20	20	20	20	20	20	20	20
Maximum kinetic energy that can be transformed into heat per deceleration during braking of moving loads	J	10	120	130	150	150	550	550	850	21000
<b>1)</b> The holding brake is broken-in at the factory. If the holding brake is not used for an extended period of time, parts of the holding brake may corrode. Corrosion reduces the holding torque.										

Hardware version &lt;RS02:

SH3...		055	0701, 0702	0703	1001, 1002, 1003	1004	1401, 1402	1403, 1404	205	
Holding torque <sup>1)</sup>	Nm (lb•in)	0.8 (7.08)	2 (17.7)	3 (26.6)	9 (79.7)	12 (106)	23 (204)	36 (319)	80 (708)	
Opening time	ms	12	12	35	40	45	50	100	200	
Coupling time	ms	6	6	15	20	20	40	45	50	
Nominal voltage	Vdc	24 +6% -10%	24 +6% -10%	24 +6% -10%	24 +6% -10%	24 +6% -10%	24 +6% -10%	24 +6% -10%	24 +6% -10%	
Nominal power (electrical pull-in power)	W	10	10	12	18	17	24	26	40	
<b>1)</b> The holding brake is broken-in at the factory. If the holding brake is not used for an extended period of time, parts of the holding brake may corrode. Corrosion reduces the holding torque.										

## Certifications

### Product Certifications

Certified by	Assigned number
UL	File E208613

### Conditions for UL 1004-1, UL 1004-6 and CSA 22.2 No. 100

#### PELV Power Supply

Use only power supply units that are approved for overvoltage category III.

#### Wiring

Use at least 60/75 °C (140/167 °F) copper conductors.

---

## Chapter 3

### Installation

---

#### DANGER

##### ELECTRIC SHOCK CAUSED BY INSUFFICIENT GROUNDING

- Verify compliance with all local and national electrical code requirements as well as all other applicable regulations with respect to grounding of the entire drive system.
- Ground the drive system before applying voltage.
- Do not use conduits as protective ground conductors; use a protective ground conductor inside the conduit.
- The cross section of the protective ground conductor must comply with the applicable standards.
- Do not consider cable shields to be protective ground conductors.

**Failure to follow these instructions will result in death or serious injury.**

#### DANGER

##### ELECTRIC SHOCK OR UNINTENDED EQUIPMENT OPERATION

- Keep foreign objects (such as chips, screws or wire clippings) from getting into the product.
- Verify the correct seating of seals and cable entries in order to avoid contamination such as deposits and humidity.

**Failure to follow these instructions will result in death or serious injury.**

This equipment has been designed to operate outside of any hazardous location. Only install this equipment in zones known to be free of a hazardous atmosphere.

#### DANGER

##### POTENTIAL FOR EXPLOSION

Install and use this equipment in non-hazardous locations only.

**Failure to follow these instructions will result in death or serious injury.**

Motors are very heavy relative to their size. The great mass of the motor can cause injuries and damage. The motor may move, tip and fall as a result of incorrect or insufficient mounting.

#### WARNING

##### HEAVY AND/OR FALLING PARTS

- Use a suitable crane or other suitable lifting gear for mounting the motor if this is required by the weight of the motor.
- Use the necessary personal protective equipment (for example, protective shoes, protective glasses and protective gloves).
- Mount the motor so that it cannot come loose (use of securing screws with appropriate tightening torque), especially in cases of fast acceleration or continuous vibration.

**Failure to follow these instructions can result in death, serious injury, or equipment damage.**

Motors can generate strong local electrical and magnetic fields. This can cause interference in electromagnetically sensitive devices.

<b>⚠ WARNING</b>
<b>ELECTROMAGNETIC FIELDS</b> <ul style="list-style-type: none"><li>• Keep persons with electronic medical implants, such as pacemakers, away from the motor.</li><li>• Do not place electromagnetically sensitive devices in the vicinity of the motor.</li></ul> <b>Failure to follow these instructions can result in death, serious injury, or equipment damage.</b>

The metal surfaces of the product may exceed 70 °C (158 °F) during operation.

<b>⚠ WARNING</b>
<b>HOT SURFACES</b> <ul style="list-style-type: none"><li>• Avoid unprotected contact with hot surfaces.</li><li>• Do not allow flammable or heat-sensitive parts in the immediate vicinity of hot surfaces.</li><li>• Verify that the heat dissipation is sufficient by performing a test run under maximum load conditions.</li></ul> <b>Failure to follow these instructions can result in death, serious injury, or equipment damage.</b>

<b>⚠ WARNING</b>
<b>IMPROPER APPLICATION OF FORCES</b> <ul style="list-style-type: none"><li>• Do not use the motor as a step to climb into or onto the machine.</li><li>• Do not use the motor as a load-bearing part.</li><li>• Use hazard labels and guards on your machine to help prevent the improper application of forces on the motor.</li></ul> <b>Failure to follow these instructions can result in death, serious injury, or equipment damage.</b>

**What Is in This Chapter?**

This chapter contains the following sections:

Section	Topic	Page
3.1	Electromagnetic Compatibility (EMC)	53
3.2	Mechanical Installation	55
3.3	Electrical Installation	64

## Section 3.1

### Electromagnetic Compatibility (EMC)

#### Electromagnetic Compatibility (EMC)

The measures for electromagnetic compatibility (EMC) are intended to minimize electromagnetic interference of the device and interference caused by the device that affects the environment. Such measures include measures to reduce interference and emission as well as to increase immunity.

Electromagnetic compatibility hinges to a great extent on the individual components used in the system. The EMC measures described in this manual may help to comply with the requirements of IEC 61800-3. You must comply with all EMC regulations of the country in which the product is operated. Also, respect any special EMC regulations that may apply at the installation site (for example, residential environments or airports).

Signal interference can cause unexpected responses of the drive system and of other equipment in the vicinity of the drive system.

#### WARNING

##### SIGNAL AND EQUIPMENT INTERFERENCE

- Install the wiring in accordance with the EMC requirements described in the present document.
- Verify compliance with the EMC requirements described in the present document.
- Verify compliance with all EMC regulations and requirements applicable in the country in which the product is to be operated and with all EMC regulations and requirements applicable at the installation site.

**Failure to follow these instructions can result in death, serious injury, or equipment damage.**

#### Motor and Encoder Cables

In terms of EMC, motor cables are especially critical since they are particularly prone to causing interference.

When planning the wiring, take into account the fact that the motor cable must be routed separately. The motor cable must be separate from mains cables or signal cables (for example, limit switches). Use only pre-assembled cables or cables that comply with the specifications and implement the EMC measures described below.

EMC measures	Effect
Keep cables as short as possible. Do not install unnecessary cable loops. Use short cables from the central grounding point in the control cabinet to the external ground connection.	Reduces capacitive and inductive interference.
Ensure that there is a ground connection between the motor flange and the mounting surface on the machine (no paint, oil and grease or any insulating material between the motor flange and the mounting surface on the machine).	Reduces emissions, increases immunity.
Connect large surface areas of cable shields, use cable clamps and ground straps.	Reduces emissions.
Do not install switching elements in motor cables or encoder cables.	Reduces interference.
Route the motor cable separately from mains cables and signal cables (for example, for limit switches), for example by using shielding plates or by keeping the cables apart from each other at a distance of at least 20 cm (5.08 in).	Reduces mutual interference.
Route the motor cable and encoder cable without cutting them. <sup>(1)</sup>	Reduces emission.
<b>(1)</b> If a cable is cut for the installation, take appropriate measures for uninterrupted shielding (such as a metal housing) at the point of the cut. Connect a large area of the cable shield to the metal housing at both ends of the cut.	

### Pre-Assembled Connection Cables (Accessories)

Using pre-assembled cables helps to reduce the possibility of wiring errors. See chapter Accessories and Spare Parts (*see page 75*).

### Equipotential Bonding Conductors

Potential differences can result in excessive currents on the cable shields. Use equipotential bonding conductors to reduce currents on the cable shields.

 <b>WARNING</b>
--

<b>UNINTENDED EQUIPMENT OPERATION</b>
---------------------------------------

- |   |
|---|
| <ul style="list-style-type: none"><li>● Use shielded cables for all fast I/O, analog I/O and communication signals.</li><li>● Ground cable shields for all analog I/O, fast I/O and communication signals at a single point<sup>1</sup>.</li><li>● Route communication and I/O cables separately from power cables.</li></ul> |
|---|

<b>Failure to follow these instructions can result in death, serious injury, or equipment damage.</b>
---

<sup>1</sup>Multipoint grounding is permissible if connections are made to an equipotential ground plane dimensioned to help avoid cable shield damage in the event of power system short-circuit currents.

---

## Section 3.2

### Mechanical Installation

---

#### What Is in This Section?

This section contains the following topics:

Topic	Page
Before Mounting	56
Cable Specifications	58
Mounting The Motor	61
Compressed Air Connection	63

## Before Mounting

### Inspecting The Product

- Verify the product version by means of the type code on the nameplate. See chapter Nameplate (*see page 13*) and chapter Type Code (*see page 15*).
- Prior to mounting, inspect the product for visible damage.

Damaged products may cause electric shock or unintended equipment operation.

 <b>DANGER</b>
<b>ELECTRIC SHOCK OR UNINTENDED EQUIPMENT OPERATION</b>
<ul style="list-style-type: none"><li>• Do not use damaged products.</li><li>• Keep foreign objects (such as chips, screws or wire clippings) from getting into the product.</li></ul>
<b>Failure to follow these instructions will result in death or serious injury.</b>

Contact your local Schneider Electric sales office if you detect any damage whatsoever to the products.

### Inspecting the Holding Brake (Option)

See chapter Inspecting/Breaking In the Holding Brake (*see page 56*).

### Cleaning the Shaft

The shaft extensions are factory-treated with an anti-corrosive. If output components are glued to the shaft, the anti-corrosive must be removed and the shaft cleaned. If required, use a grease removal agent as specified by the glue manufacturer. If the glue manufacturer does not provide information on grease removal, acetone may be used.

- Remove the anti-corrosive. Avoid direct contact of the skin and the sealing parts with the anti-corrosive or the cleaning agent.

### Mounting Surface for Flange

The mounting surface must be stable, clean, deburred and low-vibration. Ensure that the mounting surface is itself grounded, and that a potential exists between the motor flange and the mounting surface.

 <b>DANGER</b>
<b>ELECTRIC SHOCK CAUSED BY INSUFFICIENT GROUNDING</b>
<ul style="list-style-type: none"><li>• Verify compliance with all local and national electrical code requirements as well as all other applicable regulations with respect to grounding of the entire drive system.</li><li>• Ground the drive system before applying voltage.</li><li>• Do not use conduits as protective ground conductors; use a protective ground conductor inside the conduit.</li><li>• The cross section of the protective ground conductor must comply with the applicable standards.</li><li>• Do not consider cable shields to be protective ground conductors.</li></ul>
<b>Failure to follow these instructions will result in death or serious injury.</b>

Verify that the mounting surface meets the requirements in terms of dimensions and tolerances in this document.



### Conductor Cross Sections According to Method of Installation

The following sections describe the conductor cross sections for two methods of installation:

- Method of installation B2:  
Cables in conduits or cable trunking systems
- Method of installation E:  
Cables on open cable trays

Cross section in mm <sup>2</sup> (AWG)	Current-carrying capacity with method of installation B2 in A <sup>1)</sup>	Current carrying capacity with method of installation E in A <sup>1)</sup>
0.75 (18)	8.5	10.4
1 (16)	10.1	12.4
1.5 (14)	13.1	16.1
2.5 (12)	17.4	22
4 (10)	23	30
6 (8)	30	37
10 (6)	40	52
16 (4)	54	70
25 (2)	70	88
<b>1)</b> Values as per IEC 60204-1 for continuous operation, copper conductors and ambient air temperature 40°C (104 °F); see IEC 60204-1 for additional information.		

Note the derating factors for grouping of cables and correction factors for other ambient conditions (IEC 60204-1).

The conductors must have a sufficiently large cross section so that the upstream fuse can trip.

In the case of longer cables, it may be necessary to use a greater conductor cross section to reduce the energy losses.

## Cable Specifications

Using pre-assembled cables helps to reduce the possibility of wiring errors. See chapter Accessories and Spare Parts (*see page 75*).

The genuine accessories have the following properties:

### Motor Cable With Connectors

VW3...		M5100R...	E1143R...	E1144R...	E1145R...	E1153R...	E1154R...
Cable jacket, insulation		PUR orange (RAL 2003), TPM	PUR matte green (similar to RAL 6018)				
Capacitance power wires	pF/m	80	120	-	-	-	-
Wire/wire	pF/m	145	208				
Wire/shield							
Capacitance signal wires	pF/m	80	170	-	-	-	-
Wire/wire	pF/m	145	335				
Wire/shield							
Number of contacts (shielded)		(4 x 1 mm <sup>2</sup> + 2 x (2 x 0.75 mm <sup>2</sup> ))	(4 x 1.5 mm <sup>2</sup> + 2 x (2 x 0.75 mm <sup>2</sup> ))	(4 x 2.5 mm <sup>2</sup> + 2 x (2 x 1 mm <sup>2</sup> ))	(4 x 2.5 mm <sup>2</sup> + 2 x (2 x 1 mm <sup>2</sup> ))	(4 x 4 mm <sup>2</sup> + (2 x 1 mm <sup>2</sup> ) + (2 x 1.5 mm <sup>2</sup> ))	(4 x 10 mm <sup>2</sup> + (2 x 1 mm <sup>2</sup> ) + (2 x 1.5 mm <sup>2</sup> ))
Connector motor side		8-pin circular Y-TEC	8-pin circular M23		8-pin circular M40		
Connector drive side		Open					
Cable diameter	mm (in)	11 ± 0.3 (0.43 ± 0.01)	12.4 ± 0.4 (0.49 ± 0.1)	14.4 ± 0.3 (0.57 ± 0.1)	14.7 ± 0.3 (0.58 ± 0.1)	18.4 ± 0.3 (0.72 ± 0.1)	22.7 ± 0.3 (0.89 ± 0.1)
Minimum bend radius with permanently installed connection		10 times the cable diameter	5 times the cable diameter				
Minimum bend radius with flexible installation		10 times the cable diameter	12 times the cable diameter				
Nominal voltage	V						
Power wires		1000	1000				
Signal wires		1000	300				
Maximum orderable length	m (ft)	25 (82)	50 (164)			75 (246)	
Permissible temperature range during operation with permanently installed connection	°C (°F)	-40 ... 80 (-40 ... 176)	-40 ... 80 (-40 ... 176)	-50 ... 80 (-58 ... 176)	-50 ... 80 (-58 ... 176)	-40 ... 80 (-40 ... 176)	-50 ... 80 (-58 ... 176)
Permissible temperature range during operation with flexible installation	°C (°F)	-20 ... 60 (-4 ... 140)	-30 ... 80 (-22 ... 176)	-40 ... 80 (-40 ... 176)	-40 ... 80 (-40 ... 176)	-30 ... 80 (-22 ... 176)	-40 ... 80 (-40 ... 176)
Certifications / declaration of conformity		CE, DESINA	CE				

### Encoder Cable With Connectors

VW3...		M8100R...	E2094R...
Cable jacket, insulation		PUR green (RAL 6018), polypropylene (PP)	PUR matte green (similar to RAL 6018)
Number of contacts (shielded)		(3 x 2 x 0.14 mm <sup>2</sup> + 2 x 0.34 mm <sup>2</sup> )	
Connector motor side		12-pin circular Y-TEC	12-pin circular M23
Connector drive side		10-pin RJ45	10-pin RJ45
Cable diameter	mm (in)	6.8 ± 0.2 (0.27 ± 0.1)	
Minimum bend radius with permanently installed connection		10 times the cable diameter	5 times the cable diameter
Minimum bend radius with flexible installation		10 times the cable diameter	
Nominal voltage	V	300	
Maximum orderable length	m (ft)	25 (82)	50 (164)
Permissible temperature range during operation with permanently installed connection	°C (°F)	-40 ... 80 (-40 ... 176)	
Permissible temperature range during operation with flexible installation	°C (°F)	-20 ... 80 (-4 ... 176)	-40 ... 80 (-40 ... 176)
Certifications / declaration of conformity		DESINA	

### Clearance For Connectors

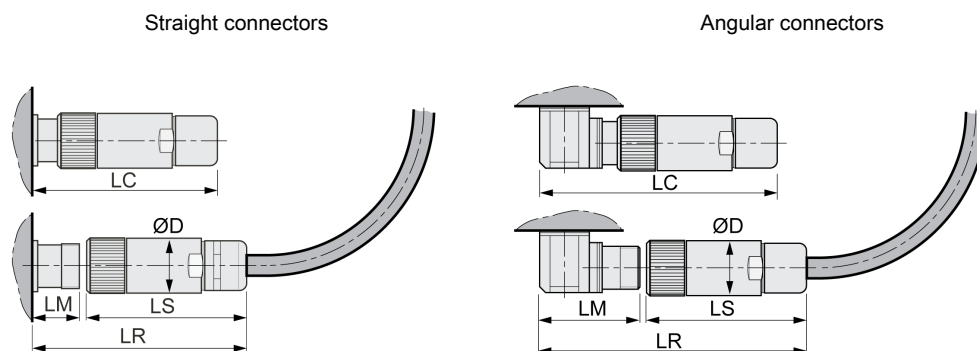

Dimensions		Motor connectors straight		Encoder connector straight
		M23	M40	M23
D	mm (in)	28 (1.1)	46 (1.81)	26 (1.02)
LS	mm (in)	76 (2.99)	100 (3.94)	51 (2.01)
LR	mm (in)	117 (4.61)	155 (6.1)	76 (2.99)
LC	mm (in)	100 (3.94)	145 (5.71)	60 (2.36)
LM	mm (in)	40 (1.57)	54 (2.13)	23 (0.91)

Dimensions		Motor connectors angular			Encoder connector angular	
		Y-TEC	M23	M40	Y-TEC	M23
D	mm (in)	18.7 (0.74)	28 (1.1)	46 (1.81)	18.7 (0.74)	26 (1.02)
LS	mm (in)	42 (1.65)	76 (2.99)	100 (3.94)	42 (1.65)	51 (2.01)
LR	mm (in)	100 (3.94)	132 (5.2)	191 (7.52)	100 (3.94)	105 (4.13)
LC	mm (in)	89 (3.50)	114 (4.49)	170 (6.69)	89 (3.50)	89 (3.5)
LM	mm (in)	58 (2.28)	55 (2.17)	91 (3.58)	58 (2.28)	52 (2.05)

## Mounting The Motor

Electrostatic discharge to the shaft may cause incorrect operation of the encoder system and result in unanticipated motor movements and damage to the bearing.

### **⚠ WARNING**

#### **UNINTENDED MOVEMENT CAUSED BY ELECTROSTATIC DISCHARGE**

Use conductive components such as antistatic belts or other suitable measures to avoid static charge by motion.

**Failure to follow these instructions can result in death, serious injury, or equipment damage.**

If the permissible environmental conditions are not respected, external substances from the environment may penetrate the product and cause unintended movement or equipment damage.

### **⚠ WARNING**

#### **UNINTENDED MOVEMENT**

- Verify that the environmental conditions are respected.
- Do not allow seals to run dry.
- Keep liquids from getting to the shaft bushing
- Do not expose the shaft sealing rings and cable entries of the motor to the direct spray of a pressure washer.

**Failure to follow these instructions can result in death, serious injury, or equipment damage.**

The metal surfaces of the product may exceed 70 °C (158 °F) during operation.

### **⚠ WARNING**

#### **HOT SURFACES**

- Avoid unprotected contact with hot surfaces.
- Do not allow flammable or heat-sensitive parts in the immediate vicinity of hot surfaces.
- Verify that the heat dissipation is sufficient by performing a test run under maximum load conditions.

**Failure to follow these instructions can result in death, serious injury, or equipment damage.**

## Mounting Position

The following mounting positions are defined and permissible as per IEC 60034-7:

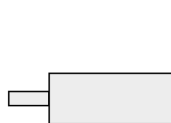

IM B5



IM V1



IM V3

## Mounting

When the motor is mounted to the mounting surface, it must be accurately aligned axially and radially and make even contact with the mounting surface. All mounting screws must be tightened with the specified tightening torque. No uneven mechanical load must be applied when the mounting screws are tightened. See chapter Technical Data ([see page 17](#)) for data, dimensions and degrees of protection (IP).

### Mounting Output Components

Output components such as pulleys and couplings must be mounted with suitable equipment and tools. Motor and output component must be accurately aligned both axially and radially. If the motor and the output component are not accurately aligned, this will cause runout and premature wear.

The maximum axial and radial forces acting on the shaft must not exceed the maximum shaft load values specified, see chapter Shaft-specific Data (*see page 33*).

If the maximum permissible forces at the motor shaft are exceeded, this will result in premature wear of the bearing or shaft breakage.

 <b>WARNING</b>
<b>UNINTENDED EQUIPMENT OPERATION DUE TO MECHANICAL DAMAGE TO THE MOTOR</b>
<ul style="list-style-type: none"><li>● Do not exceed the maximum permissible axial and radial forces at the motor shaft.</li><li>● Protect the motor shaft from impact.</li><li>● Do not exceed the maximum permissible axial force when pressing components onto the motor shaft.</li></ul>
<b>Failure to follow these instructions can result in death, serious injury, or equipment damage.</b>

## Compressed Air Connection

The compressed air generates a permanent overpressure inside the motor. This overpressure inside the motor is used to obtain degree of protection IP67.

The connection for compressed air is only suitable to reach the degree of protection IP67 in conjunction with the shaft sealing ring (IP65).

The L-shaped push-in fitting is designed for compressed air hoses made of standard plastic with a nominal diameter of 4 mm.

### Compressed Air Connection With Hardware Version $\geq$ RS03

For installation, the existing screw plug is replaced by an L-shaped push-in fitting. See chapter IP67 Kit (*see page 76*) for sources of supply of the L-shaped push-in fitting.

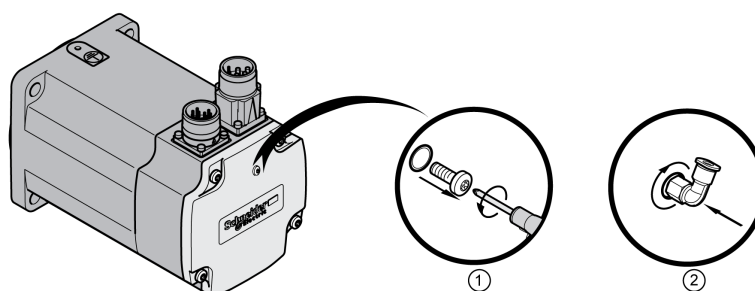

Step	Action
1	Remove the screw plug.
2	Screw the L-shaped push-in fitting into the thread. Verify proper seat of the L-shaped push-in fitting. Verify the tightening torque of the L-shaped push-in fitting: <ul style="list-style-type: none"> <li>• Tightening torque L-shaped push-in fitting: 0.6 Nm (5.31 lb•in)</li> </ul>

### Compressed Air Connection With Hardware Version $<$ RS03

The compressed air connection is only available with the option SH3••••••••2.

### Compressed Air Monitoring

Use a compressed air monitoring system.

## Section 3.3

### Electrical Installation

---

#### What Is in This Section?

This section contains the following topics:

Topic	Page
Connectors and Connector Assignments	65
Power and Encoder Connection	68
Holding Brake Connection	70



## Connectors and Connector Assignments

### Connection Overview

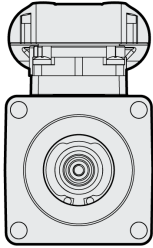
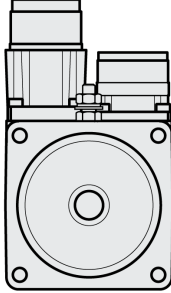
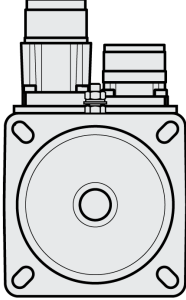
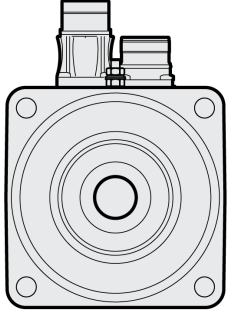
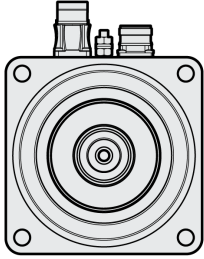
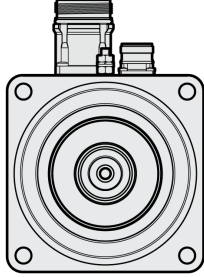
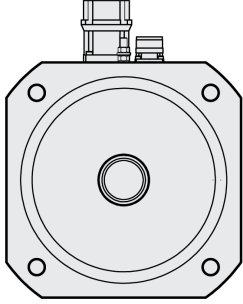
Overview of the connections			
SH3040	SH3055	SH3070	SH3100
CN1 Y-TEC 	CN1 M23 CN2 M23 	CN1 M23 CN2 M23 	CN1 M23 CN2 M23 
SH31401, SH31402	SH31403, SH31404	SH3205	
CN1 M23 CN2 M23 	CN1 M40 CN2 M23 	CN1 M40 CN2 M23 	
CN1 Motor connection CN2 Encoder connection			

### CN1 Motor Connection

Motor connector for connection of the motor phases and the holding brake.

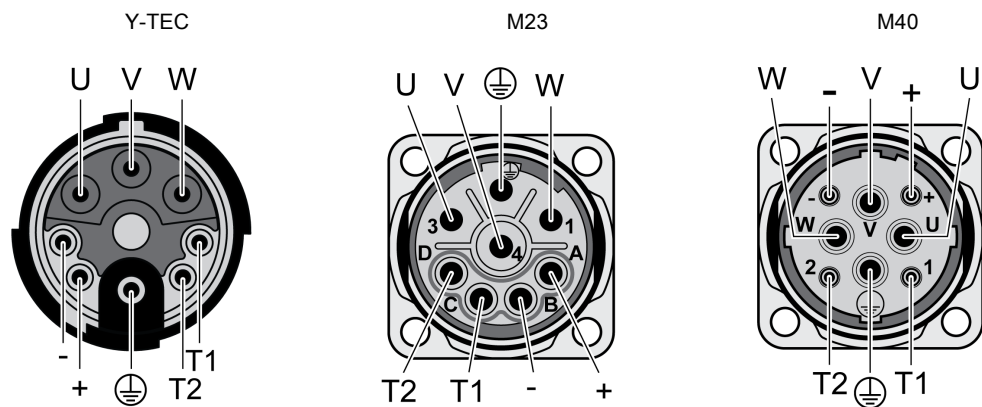

See chapter Connectors for suitable mating connectors.

The signals of the holding brake and the temperature sensor meet the PELV requirements.

Pin	Meaning	Accessory cable Wire color and wire number
U	Motor phase U	BK L1 or BK 1
V	Motor phase V	BK L2 or BK 2
W	Motor phase W	BK L3 or BK 3
PE	Protective ground conductor	GN/YE
+	Supply voltage holding brake 24 Vdc	WH or BK 8
-	Reference potential holding brake 0 Vdc	GY or BK 7
T1	Temperature sensor +	BK 6
T2	Temperature sensor -	BK 5
SHLD	Shield (to connector housing)	

**CN2 Encoder Connection Y-TEC**

Encoder connector for connection of the SinCos encoder (singleturn and multiturn)

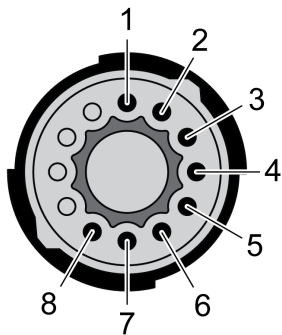

See chapter Connectors for suitable mating connectors.

The signals meet the PELV requirements.

Pin	Signal	Meaning	Pair <sup>1)</sup>	Accessory cable Wire color
1	COS_OUT	Cosine signal	2	GN
2	REFCOS_OUT	Reference for cosine signal, 2.5V	2	YE
3	SIN_OUT	Sine signal	1	WH
4	REFSIN_OUT	Reference for sine signal, 2.5 V	1	BN
5	DATA+	Receive data, transmit data	3	GY
6	DATA-	Receive data and transmit data, inverted	3	PK
7	ENC+10V	7 ... 12 V supply voltage	4	RD
8	ENC_0V	Reference potential <sup>2)</sup>	4	BL
	SHLD	Shield (to connector housing)		

1) Signal pairs must be twisted  
 2) The ENC\_0V connection of the supply voltage has no connection to the encoder housing.

### CN2 Encoder Connection M23

Encoder connector for connection of the SinCos encoder (singleturn and multiturn)

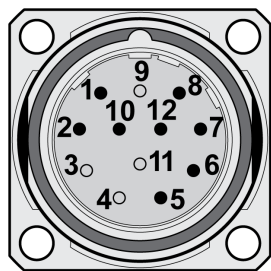

See chapter Connectors for suitable mating connectors.

The signals meet the PELV requirements.

Pin	Signal	Meaning	Accessory cable Wire color
1	REFCOS_OUT	Reference for cosine signal, 2.5V	YE
2	DATA+	Receive data, transmit data	GY
5	SIN_OUT	Sine signal	WH
6	REFSIN_OUT	Reference for sine signal, 2.5 V	BN
7	DATA-	Receive data and transmit data, inverted	PK
8	COS_OUT	Cosine signal	GN
10	ENC_0V	Reference potential <sup>1)</sup>	BL
12	ENC+10V	7 ... 12 V supply voltage	RD
	SHLD	Shield (to connector housing)	
1) The ENC_0V connection of the supply voltage has no connection to the encoder housing.			

## Power and Encoder Connection

High voltages may be present at the motor connection. The motor itself generates voltage when the motor shaft is rotated. AC voltage can couple voltage to unused conductors in the motor cable.

**⚠ DANGER**

**ELECTRIC SHOCK**

- Verify that no voltage is present prior to performing any type of work on the drive system.
- Block the motor shaft to prevent rotation prior to performing any type of work on the drive system.
- Insulate both ends of unused conductors of the motor cable.
- Only touch the motor shaft or the mounted output components if all power has been disconnected.
- Verify compliance with all local and national electrical code requirements as well as all other applicable regulations with respect to grounding of all equipment.

**Failure to follow these instructions will result in death or serious injury.**

The motor is designed for operation via a drive. Connecting the motor directly to AC voltage will damage the motor and can cause fires and initiate an explosion.

**⚠ DANGER**

**POTENTIAL FOR EXPLOSION**

Only connect the motor to a matching, approved drive in the way described in the present documentation.

**Failure to follow these instructions will result in death or serious injury.**

Drive systems may perform unintended movements if unapproved combinations of drive and motor are used. Even if motors are similar, different adjustment of the encoder system may be a source of hazards. Even if the connectors for motor connection and encoder connection match mechanically, this does not imply that the motor is approved for use.

**⚠ WARNING**

**UNINTENDED MOVEMENT**

Only use approved combinations of drive and motor.

**Failure to follow these instructions can result in death, serious injury, or equipment damage.**

See chapter Approved Drives ([see page 22](#)) for approved drives.

## Protective Ground Conductor Connection

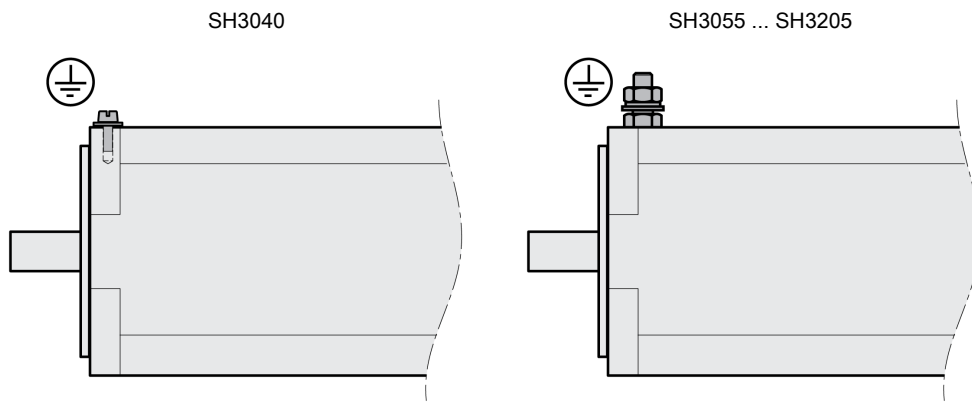

Ground the motor via a grounding screw if grounding via the flange and the protective ground conductor of the motor cable is not sufficient. Use parts with suitable corrosion protection. Note the required tightening torque and the property class of the grounding screw, see chapter Tightening Torque and Property Class Of Screws Used ([see page 19](#)).

## Assembling Cables

Insulate unused wires individually.

- Note the EMC requirements for motor cables and encoder cables, see chapter Electromagnetic Compatibility (EMC) (*see page 53*).
- Use equipotential bonding conductors for equipotential bonding.

## Connecting the Cables

Incorrect installation of the cable may damage the insulation. Broken conductors in the cable or improperly connected connectors may promote arcing within the cable.

### DANGER

#### ELECTRIC SHOCK, ARC FLASH AND FIRE

- Disconnect all power before plugging in or unplugging the connectors.
- Verify correct pin assignment of the connectors according to the specifications in this chapter before connecting the cables.
- Verify that the connectors are properly inserted and locked before applying power.
- Avoid forces or movements of the cable at the cable entries.

**Failure to follow these instructions will result in death or serious injury.**

- Place the female connector of the motor cable onto the motor connector and tighten the union nut. Proceed in the same manner with the connection cable of the encoder system. Keep the connection cables from being twisted when tightening the union nut.
- Connect the motor cable and the encoder cable to the drive according to the wiring diagram of the drive.
- Ground the shield to a large surface area. See the product manual of the drive for information on connecting the shield.

## Holding Brake Connection

Applying the holding brake while the motor is running will cause excessive wear and loss of the braking force.

<b>⚠ WARNING</b>
<b>LOSS OF BRAKING FORCE DUE TO WEAR OR HIGH TEMPERATURE</b>
<ul style="list-style-type: none"><li>• Do not use the holding brake as a service brake.</li><li>• Do not exceed the maximum number of brake applications and the kinetic energy during braking of moving loads.</li></ul>
<b>Failure to follow these instructions can result in death, serious injury, or equipment damage.</b>

See chapter Holding Brake (*see page 49*) for technical data on braking while the load moves.

Releasing the holding brake can cause an unintended movement, for example, lowering of the load in the case of vertical axes.

<b>⚠ WARNING</b>
<b>UNINTENDED MOVEMENT</b>
<ul style="list-style-type: none"><li>• Verify that there are no persons or obstacles in the zone of operation when performing a test of the holding brake.</li><li>• Take appropriate measures to avoid damage caused by falling or lowering loads or other unintended movements.</li></ul>
<b>Failure to follow these instructions can result in death, serious injury, or equipment damage.</b>

If the voltage is incorrect, the holding brake cannot be released which causes wear. If the voltage is higher than the specified voltage, the holding brake may be re-applied. If the voltage polarity is incorrect, the holding brake cannot be released.

<b>⚠ WARNING</b>
<b>MISOPERATION OF THE HOLDING BRAKE CAUSED BY INCORRECT VOLTAGE</b>
<ul style="list-style-type: none"><li>• Verify that the specified voltage is available at the holding brake connection.</li><li>• Use a properly rated voltage-sensing device for measuring.</li></ul>
<b>Failure to follow these instructions can result in death, serious injury, or equipment damage.</b>

A motor with a holding brake requires a suitable holding brake controller which releases the brake when the power stage is enabled and locks the motor shaft when the power stage is disabled.

---

## Chapter 4

### Commissioning

---

#### Commissioning

#### DANGER

##### ELECTRIC SHOCK OR UNINTENDED EQUIPMENT OPERATION

- Keep foreign objects (such as chips, screws or wire clippings) from getting into the product.
- Verify the correct seating of seals and cable entries in order to avoid contamination such as deposits and humidity.

**Failure to follow these instructions will result in death or serious injury.**

Drive systems may perform unanticipated movements because of incorrect connection or other errors.

#### WARNING

##### UNINTENDED MOVEMENT

- Verify proper wiring.
- Only start the system if there are no persons or obstructions in the zone of operation.
- Perform the first test runs without coupled loads.
- Only touch the motor shaft or the mounted output components if all power has been disconnected.

**Failure to follow these instructions can result in death, serious injury, or equipment damage.**

Drive systems may perform unintended movements if unapproved combinations of drive and motor are used. Even if motors are similar, different adjustment of the encoder system may be a source of hazards. Even if the connectors for motor connection and encoder connection match mechanically, this does not imply that the motor is approved for use.

#### WARNING

##### UNINTENDED MOVEMENT

Only use approved combinations of drive and motor.

**Failure to follow these instructions can result in death, serious injury, or equipment damage.**

See chapter Approved Drives ([see page 22](#)) for a list of approved drives.

Rotating parts may cause injuries and may catch clothing or hair. Loose parts or parts that are out of balance may be ejected.

#### WARNING

##### MOVING, UNGUARDED EQUIPMENT

Verify that rotating parts cannot cause injuries or equipment damage.

**Failure to follow these instructions can result in death, serious injury, or equipment damage.**

The metal surfaces of the product may exceed 70 °C (158 °F) during operation.

<b> WARNING</b>
<p><b>HOT SURFACES</b></p> <ul style="list-style-type: none"> <li>● Avoid unprotected contact with hot surfaces.</li> <li>● Do not allow flammable or heat-sensitive parts in the immediate vicinity of hot surfaces.</li> <li>● Verify that the heat dissipation is sufficient by performing a test run under maximum load conditions.</li> </ul> <p><b>Failure to follow these instructions can result in death, serious injury, or equipment damage.</b></p>

Motors can generate strong local electrical and magnetic fields. This can cause interference in electromagnetically sensitive devices.

<b> WARNING</b>
<p><b>ELECTROMAGNETIC FIELDS</b></p> <ul style="list-style-type: none"> <li>● Keep persons with electronic medical implants, such as pacemakers, away from the motor.</li> <li>● Do not place electromagnetically sensitive devices in the vicinity of the motor.</li> </ul> <p><b>Failure to follow these instructions can result in death, serious injury, or equipment damage.</b></p>

<b> WARNING</b>
<p><b>IMPROPER APPLICATION OF FORCES</b></p> <ul style="list-style-type: none"> <li>● Do not use the motor as a step to climb into or onto the machine.</li> <li>● Do not use the motor as a load-bearing part.</li> <li>● Use hazard labels and guards on your machine to help prevent the improper application of forces on the motor.</li> </ul> <p><b>Failure to follow these instructions can result in death, serious injury, or equipment damage.</b></p>

Prior to commissioning, verify correct installation.

Step	Action
1	Verify proper mechanical installation.
2	Verify proper electrical installation. <ul style="list-style-type: none"> <li>● Did you connect all protective ground conductors?</li> <li>● Did you properly connect and install all cables and connectors?</li> <li>● Did you tighten the cable glands properly?</li> </ul>
3	Verify that the ambient conditions are met. <ul style="list-style-type: none"> <li>● Does the installation meet the ambient conditions specified?</li> </ul>
4	Verify the output components. <ul style="list-style-type: none"> <li>● Have the installed output components been balanced and accurately aligned?</li> </ul>
5	Verify the parallel key at the shaft end of the motor. <ul style="list-style-type: none"> <li>● If you have a motor with a parallel key groove and parallel key, the parallel key must not be inserted during commissioning without output component or it must be appropriately secured.</li> </ul>
6	Verify the function of the holding brake. <ul style="list-style-type: none"> <li>● Is the holding brake able to hold the maximum load?</li> <li>● Is the holding brake released prior to the start of a movement?</li> </ul>

**NOTE:** Observe the information on commissioning in the product manual of the drive.



---

# Chapter 5

## Diagnostics and Troubleshooting

---

### What Is in This Chapter?

This chapter contains the following topics:

Topic	Page
Mechanical Issues	74
Electrical Issues	74

## Mechanical Issues

Issue	Cause	Troubleshooting
Excessive heat	Overload	Reduce load
	Holding brake not released	Verify that the holding brake controller operates properly
	Heavy pollution	Clean the motor
Whistling or knocking noise	Rolling bearings	Contact your sales office
Grinding noise	Rotating output component grinds	Align output component
Radial oscillation	Poor alignment of output component	Align output component
	Output component out of balance	Balance output component
	Shaft bent	Contact your sales office
	Resonance with machine bed	Suppress resonance
Axial oscillation	Poor alignment of output component	Align output component
	Damage to the output component	Repair/replace output component
	Resonance with machine bed	Suppress resonance

## Electrical Issues

Issue	Cause	Solution
Motor does not start or has difficulty starting	Overload	Reduce load.
	Unsuitable settings for the drive	Correct drive settings.
	Cable damaged	Replace damaged cables.
Excessive heat	Overload	Reduce power.
Heat at the terminals or connectors	Poor contact	Tighten the terminals / connectors with the specified tightening torque.

---

# Chapter 6

## Accessories and Spare Parts

---

### What Is in This Chapter?

This chapter contains the following topics:

Topic	Page
IP67 Kit	76
Motor Cables	77
Encoder Cables	80

## IP67 Kit

Degree of protection IP65 (shaft sealing ring) is a prerequisite for the use of the IP67 kit.

Description	Reference
L-shaped push-in fitting, to be acquired from Festo	QSML-B-M3-4-20

## Motor Cables

### Motor Cables 1.0 mm<sup>2</sup>

Description	Reference
Motor cable 3 m (9.84 ft), (4 x 1.0 mm <sup>2</sup> + 2 x (2 x 0.75 mm <sup>2</sup> )) shielded; motor end 8-pin circular connector Y-TEC, other cable end open	VW3M5100R30
Motor cable 5 m (16.4 ft), (4 x 1.0 mm <sup>2</sup> + 2 x (2 x 0.75 mm <sup>2</sup> )) shielded; motor end 8-pin circular connector Y-TEC, other cable end open	VW3M5100R50
Motor cable 10 m (32.8 ft), (4 x 1.0 mm <sup>2</sup> + 2 x (2 x 0.75 mm <sup>2</sup> )) shielded; motor end 8-pin circular connector Y-TEC, other cable end open	VW3M5100R100
Motor cable 15 m (49.2 ft), (4 x 1.0 mm <sup>2</sup> + 2 x (2 x 0.75 mm <sup>2</sup> )) shielded; motor end 8-pin circular connector Y-TEC, other cable end open	VW3M5100R150
Motor cable 25 m (82 ft), (4 x 1.0 mm <sup>2</sup> + 2 x (2 x 0.75 mm <sup>2</sup> )) shielded; motor end 8-pin circular connector Y-TEC, other cable end open	VW3M5100R250

### Motor Cables 1.5 mm<sup>2</sup>

Description	Reference
Motor cable 5 m (16.4 ft), (4 x 1.5 mm <sup>2</sup> + 2 x (2 x 0.75 mm <sup>2</sup> )) shielded; motor end 8-pin circular connector M23, other cable end open	VW3E1143R050
Motor cable 10 m (32.8 ft), (4 x 1.5 mm <sup>2</sup> + 2 x (2 x 0.75 mm <sup>2</sup> )) shielded; motor end 8-pin circular connector M23, other cable end open	VW3E1143R100
Motor cable 15 m (49.2 ft), (4 x 1.5 mm <sup>2</sup> + 2 x (2 x 0.75 mm <sup>2</sup> )) shielded; motor end 8-pin circular connector M23, other cable end open	VW3E1143R150
Motor cable 20 m (65.6 ft), (4 x 1.5 mm <sup>2</sup> + 2 x (2 x 0.75 mm <sup>2</sup> )) shielded; motor end 8-pin circular connector M23, other cable end open	VW3E1143R200
Motor cable 25 m (82 ft), (4 x 1.5 mm <sup>2</sup> + 2 x (2 x 0.75 mm <sup>2</sup> )) shielded; motor end 8-pin circular connector M23, other cable end open	VW3E1143R250
Motor cable 30 m (98.4 ft), (4 x 1.5 mm <sup>2</sup> + 2 x (2 x 0.75 mm <sup>2</sup> )) shielded; motor end 8-pin circular connector M23, other cable end open	VW3E1143R300
Motor cable 40 m (131 ft), (4 x 1.5 mm <sup>2</sup> + 2 x (2 x 0.75 mm <sup>2</sup> )) shielded; motor end 8-pin circular connector M23, other cable end open	VW3E1143R400
Motor cable 50 m (164 ft), (4 x 1.5 mm <sup>2</sup> + 2 x (2 x 0.75 mm <sup>2</sup> )) shielded; motor end 8-pin circular connector M23, other cable end open	VW3E1143R500

### Motor Cables 2.5 mm<sup>2</sup>

Circular connector M23:

Description	Reference
Motor cable 5 m (16.4 ft), (4 x 2.5 mm <sup>2</sup> + 2 x (2 x 1 mm <sup>2</sup> )) shielded; motor end 8-pin circular connector M23, other cable end open	VW3E1144R050
Motor cable 10 m (32.8 ft), (4 x 2.5 mm <sup>2</sup> + 2 x (2 x 1 mm <sup>2</sup> )) shielded; motor end 8-pin circular connector M23, other cable end open	VW3E1144R100
Motor cable 15 m (49.2 ft), (4 x 2.5 mm <sup>2</sup> + 2 x (2 x 1 mm <sup>2</sup> )) shielded; motor end 8-pin circular connector M23, other cable end open	VW3E1144R150
Motor cable 20 m (65.6 ft), (4 x 2.5 mm <sup>2</sup> + 2 x (2 x 1 mm <sup>2</sup> )) shielded; motor end 8-pin circular connector M23, other cable end open	VW3E1144R200
Motor cable 25 m (82 ft), (4 x 2.5 mm <sup>2</sup> + 2 x (2 x 1 mm <sup>2</sup> )) shielded; motor end 8-pin circular connector M23, other cable end open	VW3E1144R250

Description	Reference
Motor cable 30 m (98.4 ft), (4 x 2.5 mm <sup>2</sup> + 2 x (2 x 1 mm <sup>2</sup> )) shielded; motor end 8-pin circular connector M23, other cable end open	VW3E1144R300
Motor cable 40 m (131 ft), (4 x 2.5 mm <sup>2</sup> + 2 x (2 x 1 mm <sup>2</sup> )) shielded; motor end 8-pin circular connector M23, other cable end open	VW3E1144R400
Motor cable 50 m (164 ft), (4 x 2.5 mm <sup>2</sup> + 2 x (2 x 1 mm <sup>2</sup> )) shielded; motor end 8-pin circular connector M23, other cable end open	VW3E1144R500

Circular connector M40:

Description	Reference
Motor cable 5 m (16.4 ft), (4 x 2.5 mm <sup>2</sup> + 2 x (2 x 1 mm <sup>2</sup> )) shielded; motor end 8-pin circular connector M40, other cable end open	VW3E1145R050
Motor cable 10 m (32.8 ft), (4 x 2.5 mm <sup>2</sup> + 2 x (2 x 1 mm <sup>2</sup> )) shielded; motor end 8-pin circular connector M40, other cable end open	VW3E1145R100
Motor cable 15 m (49.2 ft), (4 x 2.5 mm <sup>2</sup> + 2 x (2 x 1 mm <sup>2</sup> )) shielded; motor end 8-pin circular connector M40, other cable end open	VW3E1145R150
Motor cable 20 m (65.6 ft), (4 x 2.5 mm <sup>2</sup> + 2 x (2 x 1 mm <sup>2</sup> )) shielded; motor end 8-pin circular connector M40, other cable end open	VW3E1145R200
Motor cable 25 m (82 ft), (4 x 2.5 mm <sup>2</sup> + 2 x (2 x 1 mm <sup>2</sup> )) shielded; motor end 8-pin circular connector M40, other cable end open	VW3E1145R250
Motor cable 30 m (98.4 ft), (4 x 2.5 mm <sup>2</sup> + 2 x (2 x 1 mm <sup>2</sup> )) shielded; motor end 8-pin circular connector M40, other cable end open	VW3E1145R300
Motor cable 40 m (131 ft), (4 x 2.5 mm <sup>2</sup> + 2 x (2 x 1 mm <sup>2</sup> )) shielded; motor end 8-pin circular connector M40, other cable end open	VW3E1145R400
Motor cable 50 m (164 ft), (4 x 2.5 mm <sup>2</sup> + 2 x (2 x 1 mm <sup>2</sup> )) shielded; motor end 8-pin circular connector M40, other cable end open	VW3E1145R500

**Motor Cables 4 mm<sup>2</sup>**

Description	Reference
Motor cable 5 m (16.4 ft), (4 x 4 mm <sup>2</sup> + (2 x 1 mm <sup>2</sup> ) + (2 x 1.5 mm <sup>2</sup> )) shielded; motor end 8-pin circular connector M40, other cable end open	VW3E1153R050
Motor cable 10 m (32.8 ft), (4 x 4 mm <sup>2</sup> + (2 x 1 mm <sup>2</sup> ) + (2 x 1.5 mm <sup>2</sup> )) shielded; motor end 8-pin circular connector M40, other cable end open	VW3E1153R100
Motor cable 15 m (49.2 ft), (4 x 4 mm <sup>2</sup> + (2 x 1 mm <sup>2</sup> ) + (2 x 1.5 mm <sup>2</sup> )) shielded; motor end 8-pin circular connector M40, other cable end open	VW3E1153R150
Motor cable 20 m (65.6 ft), (4 x 4 mm <sup>2</sup> + (2 x 1 mm <sup>2</sup> ) + (2 x 1.5 mm <sup>2</sup> )) shielded; motor end 8-pin circular connector M40, other cable end open	VW3E1153R200
Motor cable 25 m (82 ft), (4 x 4 mm <sup>2</sup> + (2 x 1 mm <sup>2</sup> ) + (2 x 1.5 mm <sup>2</sup> )) shielded; motor end 8-pin circular connector M40, other cable end open	VW3E1153R250
Motor cable 30 m (98.4 ft), (4 x 4 mm <sup>2</sup> + (2 x 1 mm <sup>2</sup> ) + (2 x 1.5 mm <sup>2</sup> )) shielded; motor end 8-pin circular connector M40, other cable end open	VW3E1153R300
Motor cable 40 m (131 ft), (4 x 4 mm <sup>2</sup> + (2 x 1 mm <sup>2</sup> ) + (2 x 1.5 mm <sup>2</sup> )) shielded; motor end 8-pin circular connector M40, other cable end open	VW3E1153R400
Motor cable 50 m (164 ft), (4 x 4 mm <sup>2</sup> + (2 x 1 mm <sup>2</sup> ) + (2 x 1.5 mm <sup>2</sup> )) shielded; motor end 8-pin circular connector M40, other cable end open	VW3E1153R500
Motor cable 75 m (246 ft), (4 x 4 mm <sup>2</sup> + (2 x 1 mm <sup>2</sup> ) + (2 x 1.5 mm <sup>2</sup> )) shielded; motor end 8-pin circular connector M40, other cable end open	VW3E1153R750

## Motor Cables 10 mm<sup>2</sup>

Description	Reference
Motor cable 5 m (16.4 ft), (4 x 10 mm <sup>2</sup> + (2 x 1 mm <sup>2</sup> ) + (2 x 1.5 mm <sup>2</sup> )) shielded; motor end 8-pin circular connector M40, other cable end open	VW3E1154R050
Motor cable 10 m (32.8 ft), (4 x 10 mm <sup>2</sup> + (2 x 1 mm <sup>2</sup> ) + (2 x 1.5 mm <sup>2</sup> )) shielded; motor end 8-pin circular connector M40, other cable end open	VW3E1154R100
Motor cable 15 m (49.2 ft), (4 x 10 mm <sup>2</sup> + (2 x 1 mm <sup>2</sup> ) + (2 x 1.5 mm <sup>2</sup> )) shielded; motor end 8-pin circular connector M40, other cable end open	VW3E1154R150
Motor cable 20 m (65.6 ft), (4 x 10 mm <sup>2</sup> + (2 x 1 mm <sup>2</sup> ) + (2 x 1.5 mm <sup>2</sup> )) shielded; motor end 8-pin circular connector M40, other cable end open	VW3E1154R200
Motor cable 25 m (82 ft), (4 x 10 mm <sup>2</sup> + (2 x 1 mm <sup>2</sup> ) + (2 x 1.5 mm <sup>2</sup> )) shielded; motor end 8-pin circular connector M40, other cable end open	VW3E1154R250
Motor cable 30 m (98.4 ft), (4 x 10 mm <sup>2</sup> + (2 x 1 mm <sup>2</sup> ) + (2 x 1.5 mm <sup>2</sup> )) shielded; motor end 8-pin circular connector M40, other cable end open	VW3E1154R300
Motor cable 40 m (131 ft), (4 x 10 mm <sup>2</sup> + (2 x 1 mm <sup>2</sup> ) + (2 x 1.5 mm <sup>2</sup> )) shielded; motor end 8-pin circular connector M40, other cable end open	VW3E1154R400
Motor cable 50 m (164 ft), (4 x 10 mm <sup>2</sup> + (2 x 1 mm <sup>2</sup> ) + (2 x 1.5 mm <sup>2</sup> )) shielded; motor end 8-pin circular connector M40, other cable end open	VW3E1154R500
Motor cable 75 m (246 ft), (4 x 10 mm <sup>2</sup> + (2 x 1 mm <sup>2</sup> ) + (2 x 1.5 mm <sup>2</sup> )) shielded; motor end 8-pin circular connector M40, other cable end open	VW3E1154R750

## Encoder Cables

Description	Reference
Encoder cable 3 m (9.84 ft), (3 x 2 x 0.14 mm <sup>2</sup> + 2 x 0.34 mm <sup>2</sup> ) shielded; motor end 12-pin circular connector Y-TEC, device end 10-pin connector RJ45	VW3M8100R30
Encoder cable 5 m (16.4 ft), (3 x 2 x 0.14 mm <sup>2</sup> + 2 x 0.34 mm <sup>2</sup> ) shielded; motor end 12-pin circular connector Y-TEC, device end 10-pin connector RJ45	VW3M8100R50
Encoder cable 10 m (32.8 ft), (3 x 2 x 0.14 mm <sup>2</sup> + 2 x 0.34 mm <sup>2</sup> ) shielded; motor end 12-pin circular connector Y-TEC, device end 10-pin connector RJ45	VW3M8100R100
Encoder cable 15 m (49.2 ft), (3 x 2 x 0.14 mm <sup>2</sup> + 2 x 0.34 mm <sup>2</sup> ) shielded; motor end 12-pin circular connector Y-TEC, device end 10-pin connector RJ45	VW3M8100R150
Encoder cable 25 m (82 ft), (3 x 2 x 0.14 mm <sup>2</sup> + 2 x 0.34 mm <sup>2</sup> ) shielded; motor end 12-pin circular connector Y-TEC, device end 10-pin connector RJ45	VW3M8100R250
Encoder cable 5 m (16.4 ft), (3 x 2 x 0.14 mm <sup>2</sup> + 2 x 0.34 mm <sup>2</sup> ) shielded; motor end 12-pin circular connector M23, device end 10-pin connector RJ45	VW3E2094R050
Encoder cable 10 m (32.8 ft), (3 x 2 x 0.14 mm <sup>2</sup> + 2 x 0.34 mm <sup>2</sup> ) shielded; motor end 12-pin circular connector M23, device end 10-pin connector RJ45	VW3E2094R100
Encoder cable 15 m (49.2 ft), (3 x 2 x 0.14 mm <sup>2</sup> + 2 x 0.34 mm <sup>2</sup> ) shielded; motor end 12-pin circular connector M23, device end 10-pin connector RJ45	VW3E2094R150
Encoder cable 20 m (65.6 ft), (3 x 2 x 0.14 mm <sup>2</sup> + 2 x 0.34 mm <sup>2</sup> ) shielded; motor end 12-pin circular connector M23, device end 10-pin connector RJ45	VW3E2094R200
Encoder cable 25 m (82 ft), (3 x 2 x 0.14 mm <sup>2</sup> + 2 x 0.34 mm <sup>2</sup> ) shielded; motor end 12-pin circular connector M23, device end 10-pin connector RJ45	VW3E2094R250
Encoder cable 30 m (98.4 ft), (3 x 2 x 0.14 mm <sup>2</sup> + 2 x 0.34 mm <sup>2</sup> ) shielded; motor end 12-pin circular connector M23, device end 10-pin connector RJ45	VW3E2094R300
Encoder cable 40 m (131 ft), (3 x 2 x 0.14 mm <sup>2</sup> + 2 x 0.34 mm <sup>2</sup> ) shielded; motor end 12-pin circular connector M23, device end 10-pin connector RJ45	VW3E2094R400
Encoder cable 50 m (164 ft), (3 x 2 x 0.14 mm <sup>2</sup> + 2 x 0.34 mm <sup>2</sup> ) shielded; motor end 12-pin circular connector M23, device end 10-pin connector RJ45	VW3E2094R500



---

# Chapter 7

## Service, Maintenance, and Disposal

---

### What Is in This Chapter?

This chapter contains the following topics:

Topic	Page
Service Addresses	82
Maintenance	82
Replacing the Motor	84
Shipping, Storage, Disposal	85

## Service Addresses

### Schneider Electric Automation GmbH

Schneiderplatz 1  
97828 Marktheidenfeld, Germany  
Phone: +49 (0) 9391 / 606 - 0  
Fax: +49 (0) 9391 / 606 - 4000  
Email: info-marktheidenfeld@schneider-electric.com  
Internet: <http://www.schneider-electric.com>

### Machine Solutions Service

Schneiderplatz 1  
97828 Marktheidenfeld, Germany  
Phone: +49 (0) 9391 / 606 - 3265  
Fax: +49 (0) 9391 / 606 - 3340  
Email: automation.support.de@schneider-electric.com  
Internet: <http://www.schneider-electric.com>

### Additional Contact Addresses

See the homepage for additional contact addresses:  
<http://www.schneider-electric.com>

## Maintenance

### Maintenance Plan

There are no user-serviceable parts within the motor.  
Either replace the complete motor, or contact Schneider Electric.  
The product may only be repaired by a Schneider Electric customer service center.

 <b>WARNING</b>
--

<b>UNINTENDED EQUIPMENT OPERATION</b>
---------------------------------------

- |   |
|---|
| <ul style="list-style-type: none"><li>● Only use software and hardware components approved by Schneider Electric for use with this equipment.</li><li>● Do not attempt to service this equipment outside of authorized Schneider Electric service centers.</li><li>● Update your application program every time you change the physical hardware configuration.</li></ul> |
|---|

<b>Failure to follow these instructions can result in death, serious injury, or equipment damage.</b>
---

Use only the accessories and mounting parts specified in the documentation and no third-party devices or components that have not been expressly approved by Schneider Electric. Do not modify the equipment. Include the following points in the maintenance plan of your machine.

### Connections and Fastening

- Inspect all connection cables and connectors regularly for damage. Replace damaged cables immediately.
- Verify regularly that all output elements are firmly seated.
- Verify regularly that all mechanical and electrical threaded connections are tightened to the specified torque.

### Lubricating the Shaft Sealing Ring

In the case of motors with shaft sealing ring, lubricant must be applied to the space between the sealing lip of the shaft sealing ring and the shaft with a suitable non-metallic tool. If the shaft sealing rings are allowed to run dry, the service life of the shaft sealing rings will be significantly reduced.

## Cleaning

If the permissible environmental conditions are not respected, external substances from the environment may penetrate the product and cause unintended movement or equipment damage.

### **⚠ WARNING**

#### **UNINTENDED MOVEMENT**

- Verify that the environmental conditions are respected.
- Do not allow seals to run dry.
- Keep liquids from getting to the shaft bushing (for example, in mounting position IM V3).
- Do not expose the shaft sealing rings and cable entries of the motor to the direct spray of a pressure washer.

**Failure to follow these instructions can result in death, serious injury, or equipment damage.**

Clean dust and dirt off the product at regular intervals. Insufficient heat dissipation to the ambient air may excessively increase the temperature.

Motors are not suitable for cleaning with a pressure washer. The high pressure may force water into the motor.

Care must be taken with cleaning products as some active agents may have deleterious effects on plastics and welds. When using solvents or cleaning agents, verify that the cables, cable entry seals, O-rings and motor paint are not damaged.

### ***NOTICE***

#### **CORROSION CAUSED BY CLEANING AGENTS**

- Before using a cleaning agent, carry out a compatibility test in relation to the cleaning agent and the component affected.
- Do not use alkaline cleaning agents.
- Do not use cleaning agents containing chloride.
- Do not use cleaning agents containing sulfuric acid.

**Failure to follow these instructions can result in equipment damage.**

## Inspecting/Breaking In the Holding Brake

The holding brake is broken-in at the factory. If the holding brake is not used for an extended period of time, parts of the holding brake may corrode. Corrosion reduces the holding torque.

If the holding brake does not have the holding torque indicated in the technical data, it must be broken in again.

- If the motor is mounted, dismount the motor.
- Measure the holding torque of the holding brake using a torque wrench.
- If the holding torque of the holding brake considerably differs from the specified values, manually rotate the motor shaft by 25 rotations in both directions. See chapter Holding Brake (*see page 49*) for the values.
- Repeat the process up to 3 times, until you can restore the original holding torque.  
Contact your Schneider Electric sales office if the original holding torque is not restored.

## Replacing the Rolling Bearing

When the rolling bearing is replaced, the motor is partially demagnetized and loses power.

### ***NOTICE***

#### **INOPERABLE EQUIPMENT**

Do not replace the rolling bearing.

**Failure to follow these instructions can result in equipment damage.**

For all service matters, contact your Schneider Electric representative.

## Replacing the Motor

If you replace the motor, the absolute position of the encoder is no longer valid.

### **WARNING**

#### **UNINTENDED MOVEMENT DUE TO INCORRECT ABSOLUTE POSITION**

Set the new absolute position of the encoder after having replaced the motor.

**Failure to follow these instructions can result in death, serious injury, or equipment damage.**

Step	Action
1	Power off all supply voltages. Verify that no voltages are present.
2	Label all connections and uninstall the product.
3	Note the identification number and the serial number shown on the product nameplate for later identification.
4	Install the new product as per chapter Installation ( <i>see page 51</i> ).
5	Commission the product as per chapter Commissioning ( <i>see page 71</i> ).

## Shipping, Storage, Disposal

### Shipping

The product must be protected against shocks during transportation. If possible, use the original packaging for shipping.

### Storage

The product may only be stored in spaces where the specified permissible ambient conditions are met. Protect the product from dust and dirt.

### Disposal

The product consists of various materials that can be recycled. Dispose of the product in accordance with local regulations.

Visit <http://www.schneider-electric.com/green-premium> for information and documents on environmental protection as per ISO 14025 such as:

- EoLi (Product End-of-Life Instructions)
- PEP (Product Environmental Profile)





## A

### Axial forces

Tension or compression forces acting longitudinally on the shaft

## C

### Centering collar

Centering device at the motor flange that allows for accurate motor mounting.

## D

### Degree of protection

The degree of protection is a standardized specification for electrical equipment that describes the protection against the ingress of foreign objects and water (for example: IP 20).

### DOM

Date of manufacturing: The nameplate of the product shows the date of manufacture in the format DD.MM.YY or in the format DD.MM.YYYY. For example:

31.12.11 corresponds to December 31, 2011

31.12.2011 corresponds to December 31, 2011

### Drive system

System consisting of controller, drive and motor.

## E

### EMC

Electromagnetic compatibility

## L

### Length

In the type code, the length is defined in terms of the number of stacks.

## P

### PELV

Protective Extra Low Voltage, low voltage with isolation. For more information: IEC 60364-4-41

## R

### Radial forces

Forces that act radially on the shaft

## S

### Size

In the type code, the size is defined in terms of the flange size.







## A

Approved drives, *22*

## C

cable specifications, *58*

## D

disposal, *85, 85*

## E

EMC, *53*

    Motor cable and encoder cable, *53*

Encoder, *47*

Encoder cable

    EMC requirements, *53*

Equipotential bonding conductors, *54*

## F

force for pressing on, *33*

## G

general characteristics, *18*

## H

holding brake, *49*

holding brake connection, *70*

## I

Installation, *51*

## M

maintenance, *82*

Motor cable

    EMC requirements, *53*

mounting position, *61*

## N

nameplate, *13*

## R

Replacing the motor, *84*

## S

SEK37 Singleturn, *48*

SEL37 Multiturn, *48*

service addresses, *82*

shaft load, *33*

shaft-specific data, *33*

shipping, *85*

SKM36 Multiturn, *47*

SKS36 Singleturn, *47*

storage, *85*

## T

type code, *15*

