

INSTALLATION INSTRUCTIONS T-PMPI-268-PC

©Panduit Corp. 2005

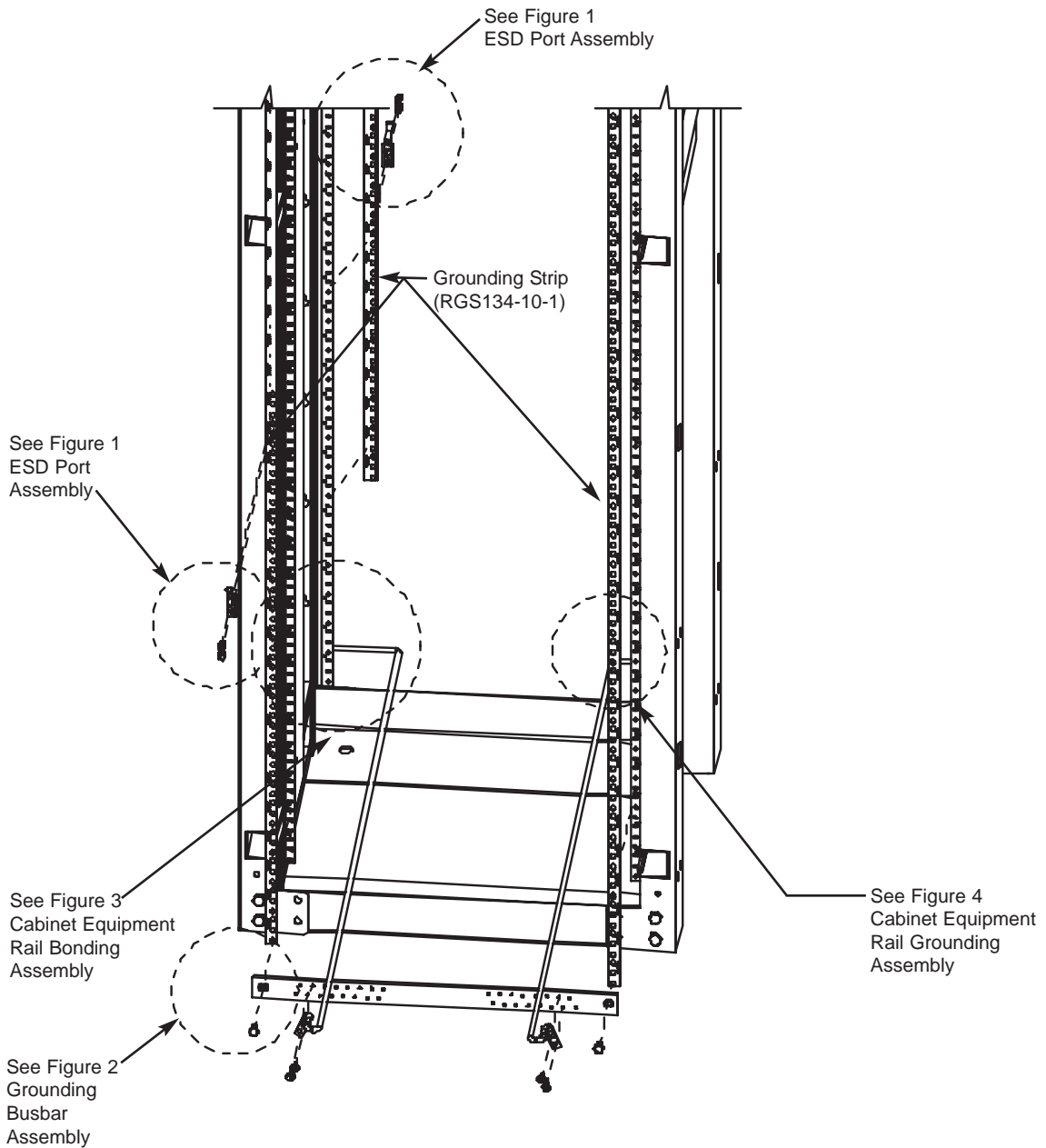

General Assembly Notes

1. Clean all mating surfaces prior to installation using the provided cleaning pad.
2. Apply a very thin layer of anti-oxidizing paste (provided) to all mating surfaces prior to installation.
3. All M6 Thread Forming Screws are to be fastened using a 7mm socket wrench and an installation torque of 35 in-lbs.
4. All 1/4-20 Bolts are to be fastened using a 7/16" socket wrench and an installation torque of 7 ft-lbs.

INSTALLATION INSTRUCTIONS T-PMPI-268-PC

©Panduit Corp. 2005

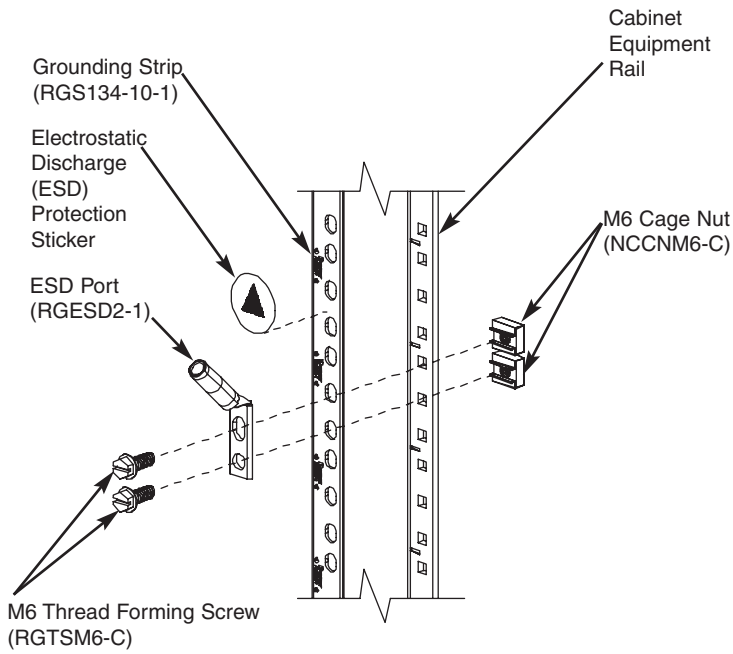

Figure 1. ESD Port Assembly

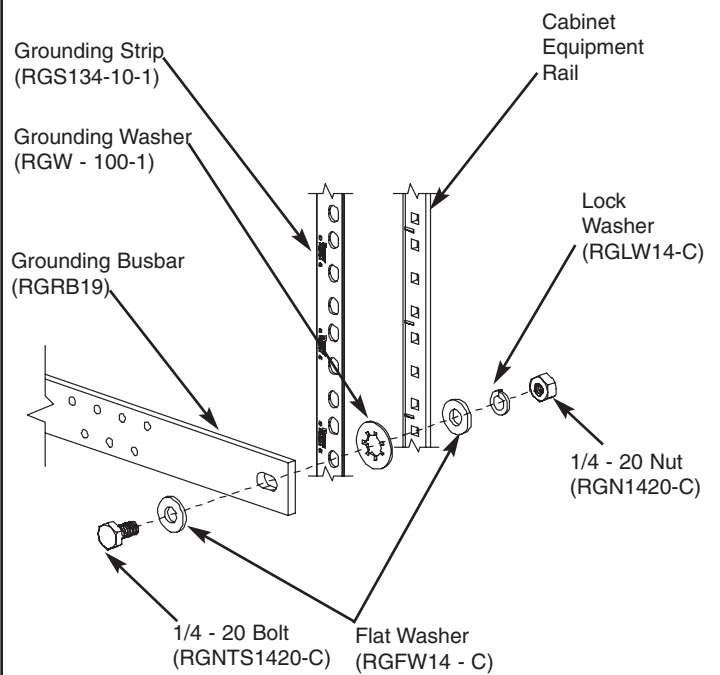

Figure 2. Grounding Busbar Assembly

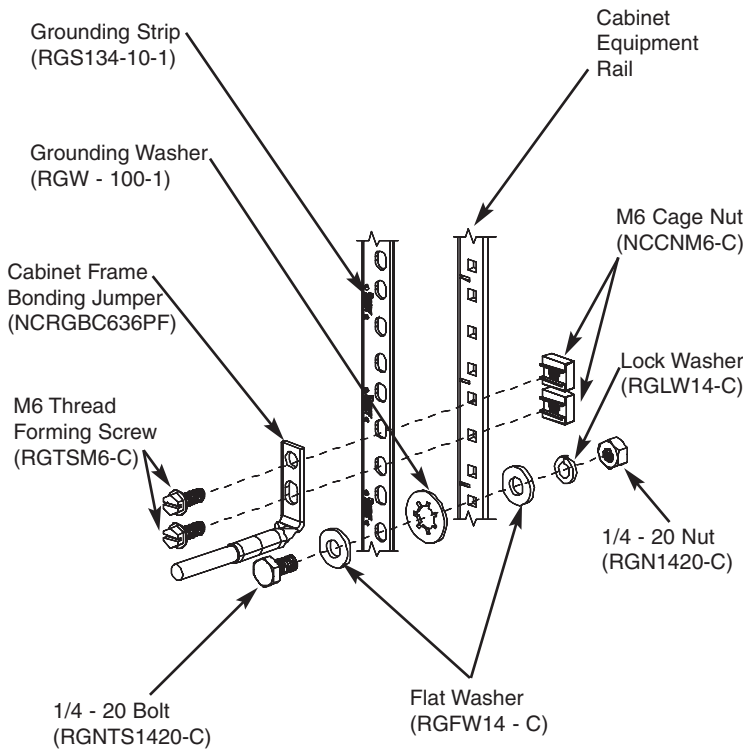

Figure 3. Cabinet Equipment Rail Bonding Assembly

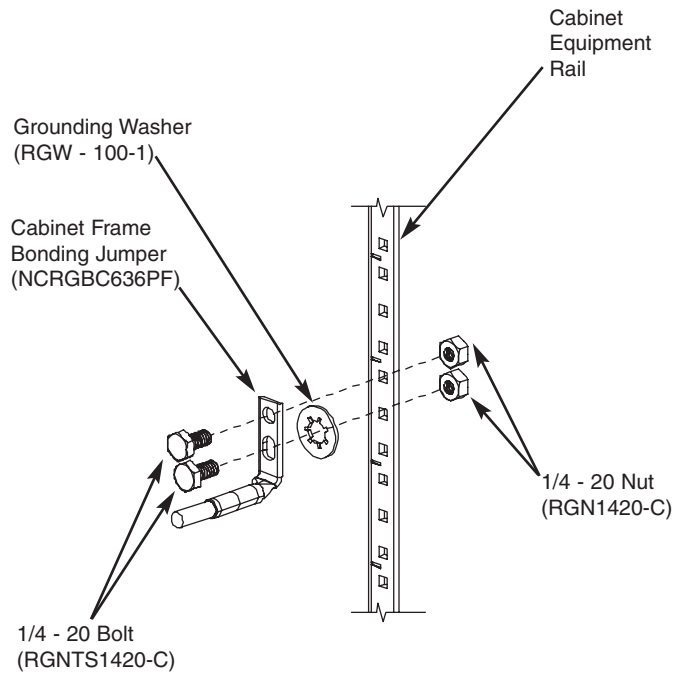

Figure 4. Cabinet Equipment Rail Grounding Assembly

For Instructions in Local Languages
and Technical Support:

http://www.panduit.com/resources/install_maintain.asp



www.panduit.com

E-mail:
cs@panduit.com

Fax:
(815)485-5839