

THIS COPY IS PROVIDED ON A RESTRICTED BASIS AND IS NOT TO BE USED IN ANY WAY DETRIMENTAL TO THE INTERESTS OF PANDUIT CORP.

PANDUIT PART NUMBER	WEIGHT lbs. / 100 Pcs. [g / 100 Pcs.]	CABLE TIE CROSS SECTION COMPATABILITY
ABMM-AV	0.113 [51.3]	MINIATURE INTERMEDIATE



NOTES:

- SEE www.panduit.com FOR CURRENT PART NUMBER SUFFIX DESIGNATION AND FOR PACKAGE SIZE AND PART COLOR.
- MOUNTS ARE SUPPLIED IN STRIPS OF TWO.
- MOUNT HAS A CONTINUOUS OPERATING TEMPERATURE OF 158°F (70°C).
- DIMENSIONS IN BRACKETS ARE METRIC [mm]
- NO WARRANTY, EXPRESSED OR IMPLIED, IS MADE BY PANDUIT WITH RESPECT TO ADHESIVE BOND PERFORMANCE. AMONG OTHER THINGS, THE CONDITIONS UNDER WHICH THESE MOUNTS MAY BE APPLIED ARE BEYOND PANDUIT'S CONTROL.
- ALL MATERIALS AND COMPONENTS USED MEET THE MATERIAL RESTRICTIONS OF RoHS (EUROPEAN DIRECTIVE 2011/65/EU ON THE RESTRICTION OF HAZARDOUS SUBSTANCES) AS PROPOSED BY THE RoHS TECHNICAL ADAPTATION COMMITTEE.
- UNLESS OTHERWISE SPECIFIED DIMENSIONAL TOLERANCES ARE: ±0.030 [0.76]

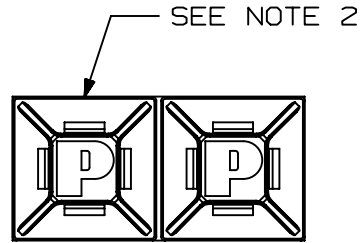
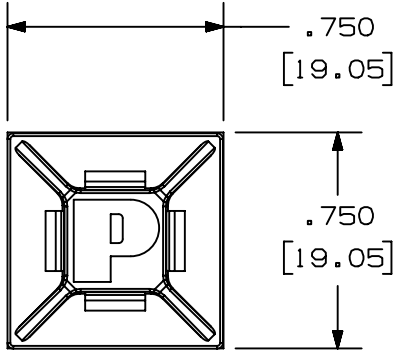

A TO APPLY MOUNTS:

PRELIMINARY: CLEAN SURFACE WITH A CLEAN CLOTH AND ISOPROPYL ALCOHOL. ALLOW SURFACE TO AIR DRY.
 STEP 1: SCORE WITH UTILITY KNIFE BETWEEN MOUNT PAIRS TO BREAK WELD BACK.
 STEP 2: REMOVE MOUNT FROM PROTECTIVE LINER.
 STEP 3: PLACE IN DESIRED LOCATION.
 STEP 4: APPLY PRESSURE TO TOP SURFACE OF MOUNT.
 (IT IS RECOMMENDED THAT HIGH BOND ADHESIVE MOUNTS DWELL FOR 8 HOURS AFTER INSTALLATION, PRIOR TO LOADING)

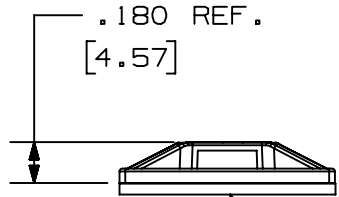
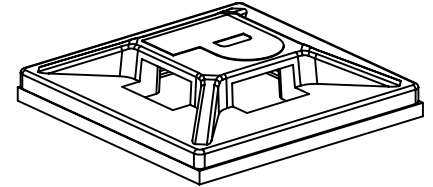

B ADHESIVE BACKING:
C PRESSURE SENSITIVE FOAM TAPE 0.025 [0.6mm] THICK WITH PROTECTIVE LINER. MOUNT IS DESIGNED TO SUPPORT 0.56 lbs. [254 g] MAX. WEIGHT ON A CLEAN, DRY, SMOOTH, GREASE-FREE SURFACE.

PART NUMBER		ABMM-AV		
TITLE		VHB ADHESIVE BACKED MOUNTS		
CUSTOMER DRAWING				
ITEM REVISION NAME		00202BBB/00		
DATASET FILE NAME		00202BBB_DC_ABMM-AV/00C		
MATERIAL		ABS		
DRAWING NUMBER		00202BBB-DC		
DRAWN BY	DATE	CHK	SCALE	SIZE
BDK	10.09.20	DAEI	NTS	A
SHEET 1 OF 1				

00C	05.06.21	BDK	MRJS	JADE	F: TEMPERATURE WAS 185°F (85°C)	101264
00B	03.15.21	BDK	MRJS	JADE	A: REVISED APPLICATION STEPS B: CHANGED DIMENSION ORIGIN C: CORRECTED SUPPORT WEIGHT; TAPE THICKNESS WAS 0.027 [0.69] D: TEMPERATURE WAS 120°F (49°C) E: MINIATURE WAS MEDIUM	098736
00	10.09.20	BDK	DAEI	MBVE	RELEASED TO PRODUCTION	GAECN081503
REV	DATE	BY	CHK	APR	DESCRIPTION	ECN

A-SIZE CUSTOMER