

# CC PrimeLine NFC/LEDSet



## PRIMELINE NFC/LEDSET S-MD

**186875, 186876, 186877, 186878**

### Typical Applications

Built-in in compact luminaires

- Street lighting
- Industrial lighting



### PrimeLine NFC/LEDSet S-MD

- **SELECTABLE OUTPUT CURRENT VIA NFC OR LEDSET**
- **DIMMABLE: DALI (ED. 2)**
- **MULTI DIM FUNCTION**
- **MIDNIGHT FUNCTION**
- **VERY LOW RIPPLE CURRENT: < 5%**
- **SURGE PROTECTION: UP TO 10 KV**
- **LONG SERVICE LIFE: UP TO 100,000 HRS.**
- **PRODUCT GUARANTEE: 5 YEARS**



## PrimeLine NFC/LEDSet S-MD

### Product features

- Compact casing shape

### Functions

- Selectable current output by secondary side LEDSet terminal or NFC
- Programmable via NFC interface (contactless)
  - Line Switch (power reduction via control phase)
  - MidNight function
  - Mains Voltage Dimming (dimming over mains voltage amplitude)
  - Constant Lumen Output (CLO)

### Electrical features

- Mains voltage: 220–240 V ±10%
- Mains frequency: 50–60 Hz
- DC operation: 176–276 V, 0 Hz
- Push-in terminals: 0.2–1.5 mm<sup>2</sup>
- Power factor at full load: > 0.95
- Open circuit voltage (U<sub>max.</sub>): 60 V (186875, 186876) or 120 V (186877)
- Max. working voltage (U<sub>OUT</sub>): 250 V (186878)
- Secondary side switching of LED modules is not allowed.

### Dimming

- Multi-Dim: DALI2, Line Switch (power reduction via control phase), MidNight function, Mains Voltage Dimming (dimming over mains voltage amplitude)
- Dimming range: 10 to 100%
- If no dimming interface is connected, brightness will stay at 100%.

### Safety features

- Protection against transient main peaks up to 6 kV (between L and N) and up to 10 kV (between L/N and PE)
- Electronic short-circuit protection
- Overtemperature protection
- Protection against "no load" operation
- Degree of protection: IP20
- Protection class II
- SELV (except 186878)

### Packaging units

Ref. No.	Packaging unit		Weight g
	Pieces per box	Boxes per pallet	
186875	20	64	210
186876	20	64	210
186877	20	32	300
186878	10	64	780

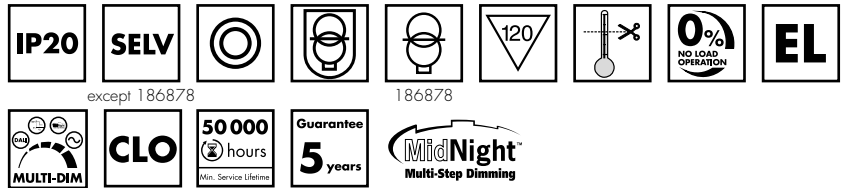

### Applied standards

- EN 61000-3-2
- EN 61347-1
- EN 61347-2-13
- EN 61547
- EN 62384
- EN 62386-101 DALI Ed. 2, Part101,102,207
- EN 55015

### Dimensions

Ref. No.	Casing	Length a mm	Width b mm	Height c mm
186875	K3.1	123.4	79.4	33
186876	K3.1	123.4	79.4	33
186877	K72	133	76.7	39.5
186878	K74	149.9	89.9	39.5

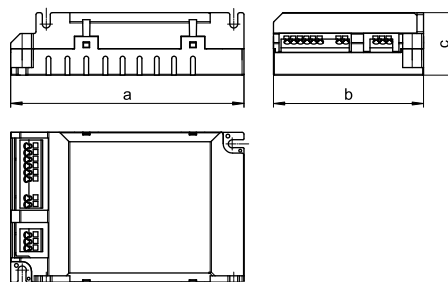

### Product guarantee

- 5 years
- The conditions for the Product Guarantee of the Vossloh-Schwabe Group shall apply as published on our homepage ([www.vossloh-schwabe.com](http://www.vossloh-schwabe.com)). We will be happy to send you these conditions upon request.



**Dimming**  
Analogue



**Current adjustment**

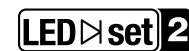

The values contained in this data sheet can change due to technical innovations. Any such changes will be made without separate notification.

## Product drawings and photos

### K3.1

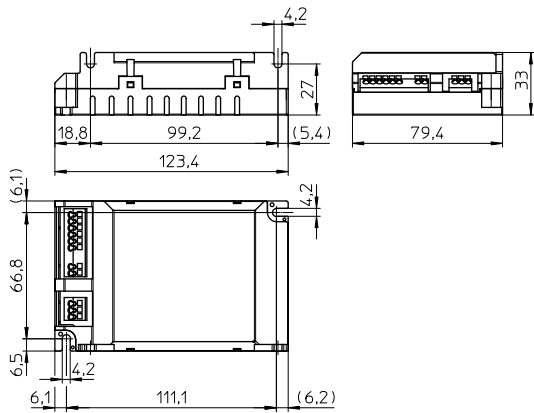

### K72

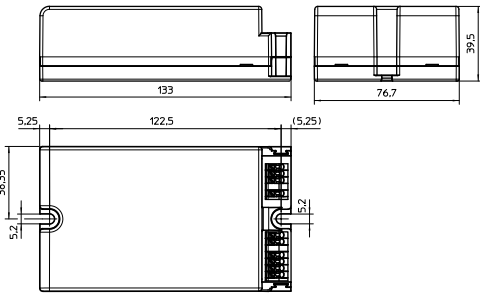

### K74

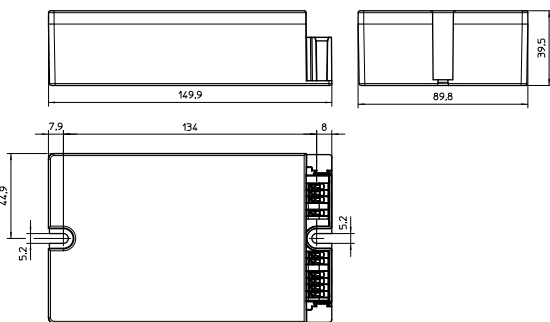

The values contained in this data sheet can change due to technical innovations. Any such changes will be made without separate notification.

## Electrical characteristics

Max. output W	Type	Ref. No.	Voltage 50–60 Hz V	Mains current mA	Inrush current A / $\mu$ s	Current output DC mA ( $\pm$ 5%)	Factory settings mA	Voltage output DC (V)	THD at full load % (230 V)	Efficiency at full load % (230 V)	Ripple 100 Hz %
22	ECXd 1050.352	<b>186875</b>	170–264	120	25 / 150	200–1050	700	10–38	10	87	< 5
40	ECXd 1050.353	<b>186876</b>	170–264	200	25 / 180	200–1050	700	15–56	10	90	< 5
75	ECXd 1050.354	<b>186877</b>	170–264	360	54 / 190	200–1050	700	35–115	5	93	< 6
110	ECXd 1050.355	<b>186878</b>	170–264	540	70 / 170	200–1050	700	80–220	10	93	< 5

## Maximum ratings

Exceeding the maximum ratings can lead to reduction of service life or destruction of the drivers.

Ref. No.	Ambient temperature range		Operation humidity range		Storage temperature range		Storage humidity range		Max. operation temperature at $t_c$ point °C	Degree of protection
	°C min.	°C max.	% min.	% max.	°C min.	°C max.	% min.	% max.		
186875	-40	+60	5	85	-25	+80	5	95	+75	IP20
186876	-40	+60			-25	+80			+80	
186877	-40	+60			-40	+85			+85	
186878	-40	+55			-40	+85			+85	

## Expected service life time

at operation temperatures at  $t_c$  point

Operation current	Ref. No. 186875		186876		186877, 186878	
	63 °C	75 °C	68 °C	80 °C	73 °C	85 °C
hrs.	100,000	50,000	100,000	50,000	100,000	50,000

## Product labels

**VS LIGHTING SOLUTIONS**  
Vossloh-Schwabe Deutschland GmbH  
Hohe Steinert 8, D-58509 Lüdenscheid  
Electronic Converter for LED  
**Type ECXd 1050.352**  
Ref.-No. 186875

EN 55015  
EN 61000-3-2  
EN 61547  
EN 61347-2-13  
EN 62384

OUTPUT  
I<sub>rated</sub> (mA) 200...1050  
U<sub>rated</sub> (V) 10...38  
P<sub>rated</sub> (W) 22  
t<sub>a</sub> (°C) -40...60  
U<sub>max</sub>(V) 60  
 $\lambda$   $\geq$ 0.95

LED+, LED-, LED, LT2, NTC, DA, DA

SEC I<sub>in</sub>=70...1050mA

t<sub>c</sub> = 75 °C

PRI  
f<sub>N</sub>=50/60Hz

SD2, N, L

SELV

MULTI-DIM  
DALI  
LEDset 2

Made in Bulgaria(EU)

**VS LIGHTING SOLUTIONS**  
Vossloh-Schwabe Deutschland GmbH  
Hohe Steinert 8, D-58509 Lüdenscheid  
Electronic Converter for LED  
**Type ECXd 1050.353**  
Ref.-No. 186876

EN 55015  
EN 61000-3-2  
EN 61547  
EN 61347-2-13  
EN 62384

OUTPUT  
I<sub>rated</sub> (mA) 200...1050  
U<sub>rated</sub> (V) 15...56  
P<sub>rated</sub> (W) 40  
t<sub>a</sub> (°C) -40...60  
U<sub>max</sub>(V) 60  
 $\lambda$   $\geq$ 0.95

LED+, LED-, LED, LT2, NTC, DA, DA

SEC I<sub>in</sub>=70...1050mA

t<sub>c</sub> = 80 °C

PRI  
f<sub>N</sub>=50/60Hz

SD2, N, L

SELV

MULTI-DIM  
DALI  
LEDset 2

Made in Bulgaria(EU)

**VS LIGHTING SOLUTIONS**  
Vossloh-Schwabe Deutschland GmbH  
Hohe Steinert 8, D-58509 Lüdenscheid  
Electronic Converter for LED  
**Type ECXd 1050.354**  
Ref.-No. 186877

EN 55015  
EN 61000-3-2  
EN 61547  
EN 61347-2-13  
EN 62384

OUTPUT  
I<sub>rated</sub> (mA) 200...1050  
U<sub>rated</sub> (V) 35...115  
P<sub>rated</sub> (W) 75  
t<sub>a</sub> (°C) -40...60  
U<sub>max</sub>(V) 120  
 $\lambda$   $\geq$ 0.95

LED+, LED-, LED, LT2, NTC, DA, DA

SEC I<sub>in</sub>=70...1050mA

t<sub>c</sub> = 85 °C

PRI

SD2, N, L

SELV

MULTI-DIM  
DALI  
LEDset 2

Made in Bulgaria(EU)

**VS LIGHTING SOLUTIONS**  
Vossloh-Schwabe Deutschland GmbH  
Hohe Steinert 8, D-58509 Lüdenscheid  
Electronic Converter for LED  
**Type ECXd 1050.355**  
Ref.-No. 186878

EN 55015  
EN 61000-3-2  
EN 61547  
EN 61347-2-13  
EN 62384

OUTPUT  
I<sub>rated</sub> (mA) 200...1050  
U<sub>rated</sub> (V) 80...220  
P<sub>rated</sub> (W) 110  
t<sub>a</sub> (°C) -40...55  
U<sub>max</sub>(V) 250  
 $\lambda$   $\geq$ 0.95

LED+, LED-, LED, LT2, NTC, DA, DA

SEC I<sub>in</sub>=70...1050mA

t<sub>c</sub> = 85 °C

PRI

SD2, N, L

SELV

MULTI-DIM  
DALI  
LEDset 2

Made in Bulgaria(EU)

The values contained in this data sheet can change due to technical innovations. Any such changes will be made without separate notification.

## Typ. performance graphs for 186875 / Type ECXd 1050.352

### Working area

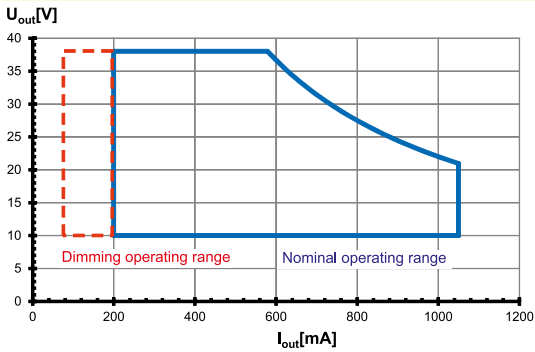

### Efficiency

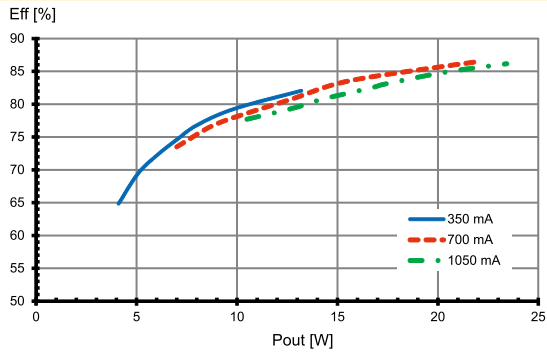

### Power factor

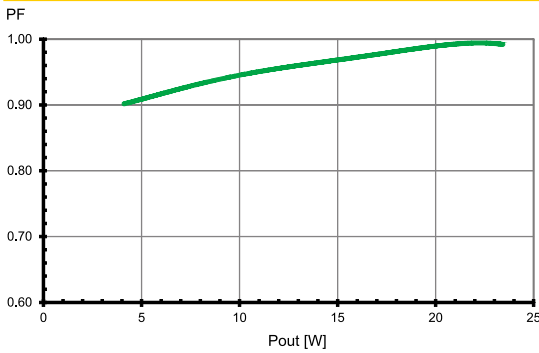

### Total harmonic factor (THD)

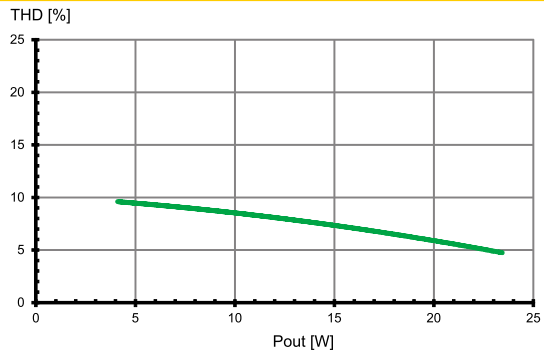

## Typ. performance graphs for 186876 / Type ECXd 1050.353

### Working area

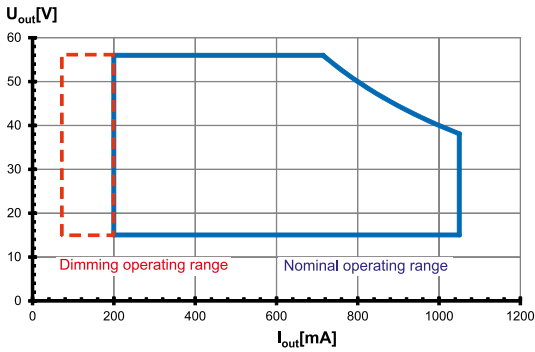

### Efficiency

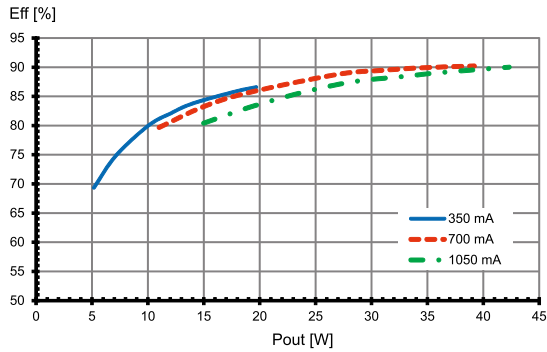

### Power factor

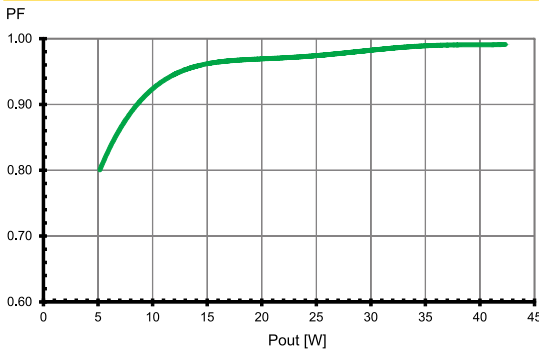

### Total harmonic factor (THD)

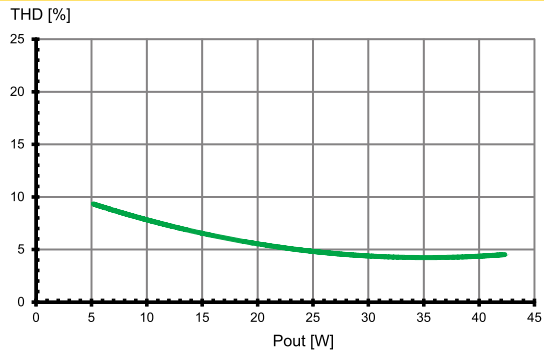

The values contained in this data sheet can change due to technical innovations. Any such changes will be made without separate notification.

## Typ. performance graphs for 186877 / Type ECXd 1050.354

### Working area

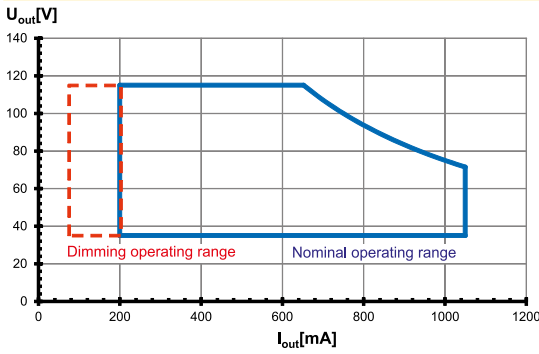

### Efficiency

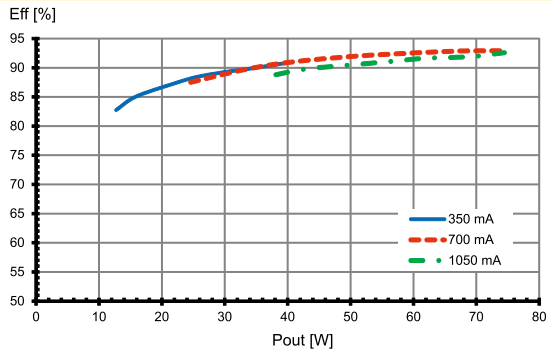

### Power factor

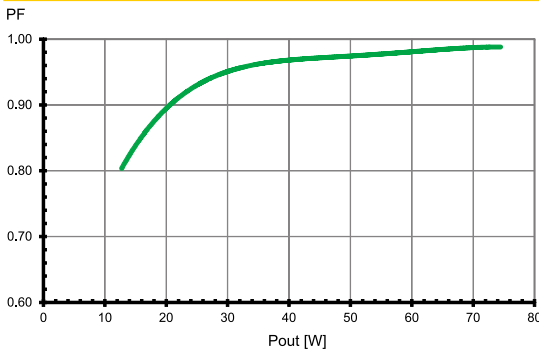

### Total harmonic factor (THD)

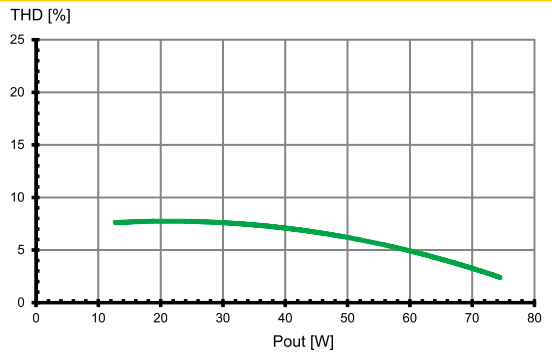

## Typ. performance graphs for 186878 / Type ECXd 1050.355

### Working area

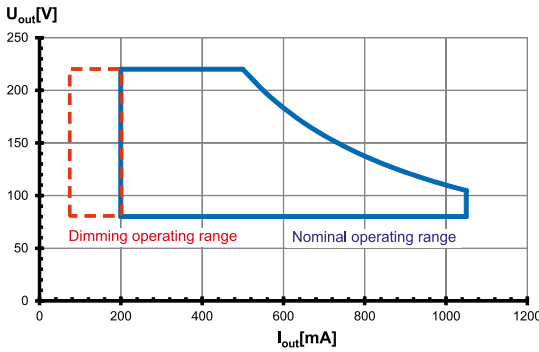

### Efficiency

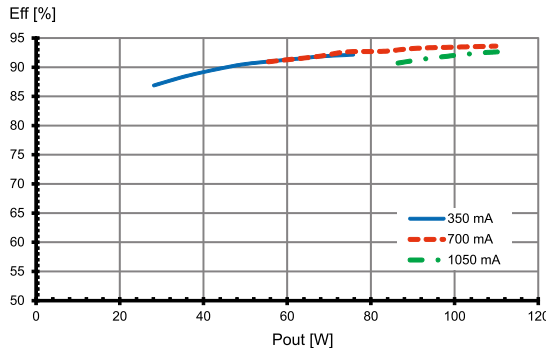

### Power factor

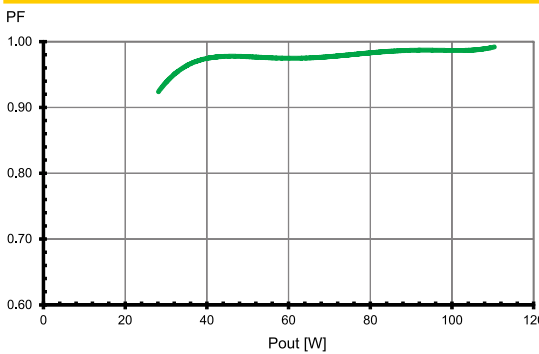

### Total harmonic factor (THD)

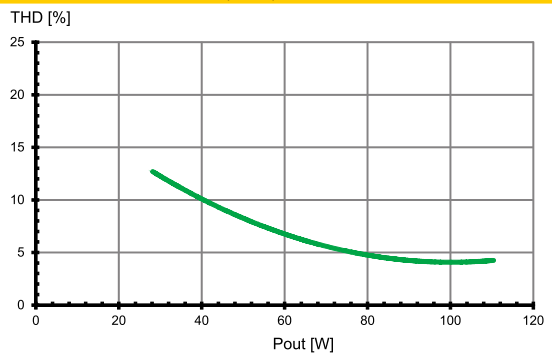

The values contained in this data sheet can change due to technical innovations. Any such changes will be made without separate notification.



## Safety functions

- Transient mains peaks protection:  
Values are in compliance with EN 61547 (interference immunity).  
Surges between L-N: up to 6 kV  
Surges between L/N-PE: up to 10 kV
- Short-circuit protection: The control gear is protected against permanent short-circuit with automatic restart function.
- Overload protection: The control gears have overload protection. In case of overload the control gear will reduce the output current.
- Overheating: The control gear has overheating protection. In case of overheating the control gear will reduce the output current and shut down.
- No load operation: The control gear is protected against no load operation (open load) and switches off when no load is connected.
- If any of the above mentioned safety functions will be triggered, disconnect the control gear from the power supply then find and eliminate the cause of the problem.

## Output voltage (U<sub>OUT</sub>)

According to EN 61347-1, U<sub>OUT</sub> indicates which voltage can occur at the output terminals directly or between the output terminals and the PE terminal of the LED driver. This value is given for non-insulated drivers. The used LED module must have an insulation voltage that is at least as high as the specified U<sub>OUT</sub> voltage of the driver.

## Leakage current

Leakage currents are present in all electronic converters or luminaires with PE connection and must be observed especially when using non-insulated LED drivers.

The PCB surfaces of LED modules form a capacitance with grounded LED aluminum circuit boards, heat sinks or mounting plates. This leads to capacitive leakage currents between the connection poles of the LED (+ and -) and the PE terminal. These capacitances should be kept as small as possible, since they are responsible for a possible glowing or flickering of the LEDs in standby mode. In extreme cases, the maximum permissible leakage current of the luminaire according to EN 60598 paragraph 10.3 may be exceeded. The leakage current is also relevant when using RCD circuit breakers.

## NTC for thermal protection of the LED module

The LEDs can be thermally protected by the NTC interface (Negative Temperature Coefficient Resistor) of the operating device, which ensures the current will be reduced when a critical temperature is reached.

Connect an NTC on the LED module connectors which are connected to the LED driver as shown in the wiring diagram.

- Max. NTC resistor: 68 kΩ
- Start of output current reduction: 6.3–5 kΩ
- End of output current reduction: 5–4.5 kΩ

## Dimming

- Minimum load: 70 mA or 6.67 % of the selected output current
- Dimming current tolerance: ±3% of the adjusted output current

## DALI2

In this operating mode, the driver can be controlled in a DALI application via the bidirectional DALI interface.

Application control allows the driver to be integrated into a light management system. The drivers are DALI2 certified and support stepless dimming, status queries and addressing of each individual luminaire.

Compared to devices based on the DALI1 version, DALI2-based drivers provide more functions and higher interoperability in the system.

## Line Switch

Dimming over external control phase

Predefined dimming levels and the polarity of the phase can be set using the Tuner4Tronic® software.

The SD/SD2 connector also allows the following functions via a mains powered motion sensor.

## MidNight function

Automatic dimming via an integrated timer (no real-time clock).

Five independent dimming levels and zones can be set using the Tuner4Tronic software.

## Mains Voltage Dimming

Dimming via the mains voltage amplitude

This feature is often used in combination with electromagnetic ballasts in outdoor applications. The dimming behaviour can be adjusted via the Tuner4Tronic® software.

## Constant lumen output (CLO)

The decrease in the luminous flux of an LED module can be compensated over its entire lifetime via a preprogrammed current curve. This not only ensures stable lighting but also saves energy and increases the lifetime of the LEDs.

The values contained in this data sheet can change due to technical innovations. Any such changes will be made without separate notification.

## System architecture

- You can program the NFC LED drivers contactless with the Feig Programmer.
- The LED driver is programmed via NFC in a de-energised state.
- The use of the NFC programmer is flexible in the production or already in the pre-assembly process. A complex commissioning is not required. The operation and parameterization is done in the simplest way. All operating parameters can be individually programmed and updated.
- The exact description of the programming can be found in the operation manual of the VS Tuner4Tronic software.



The values contained in this data sheet can change due to technical innovations. Any such changes will be made without separate notification.



## Assembly and Safety Information

Installation must be carried out under observation of the relevant regulations and standards. Installation must be carried out in a voltage-free state (i.e. disconnection from the mains). The following advices must be observed; non-observance can result in the destruction of the LED drivers, fire and/or other hazards.

### Mandatory regulations

- DIN VDE 0100
- EN 60598-1

### Mechanical mounting

- Mounting position: Built-in: Any position inside a luminaire is allowed
- Mounting location: LED drivers are designed for integration into luminaires or comparable devices. Installation in outdoor luminaires: degree of protection for luminaire with water protection rate  $\geq 4$  (e.g. IP54 required).
- Degree of protection: IP20
- Clearance: Min. 0.10 m from walls, ceilings and insulation
- Surface: Solid and plane surface for optimum heat dissipation required.
- Heat transfer: If the driver is destined for installation in a luminaire, sufficient heat transfer must be ensured between the driver and the luminaire casing. LED drivers should be mounted with the greatest possible clearance to heat sources. During operation, the temperature measure at the driver's  $t_c$  point must not exceed the specified maximum value.
- Fastening: Using M4 screws in the designated holes
- Tightening torque: 0.2 Nm

### Electrical installation

- Connection terminals: Push-in terminals for rigid or flexible conductors with a section of 0.2–1.5 mm<sup>2</sup>
- Stripped length: 8.5–9.5 mm
- Wiring: The mains conductor within the luminaire must be kept short (to reduce the induction of interference). Mains and lamp conductors must be kept separate and if possible should not be laid in parallel to one another.
- Polarity: Please ensure the correct polarity of the leads prior to commissioning. Reversed polarity can destroy the modules.
- Through-wiring: Is not allowed.
- Secondary load: The sum of forward voltages of LED loads has to be within the tolerances which are mentioned in the table "Electrical Characteristics" in this data sheet.

- Wiring diagram:

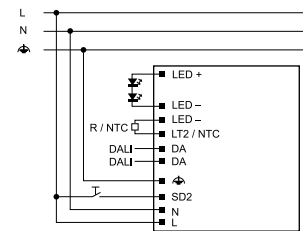

### Selection of automatic cut-outs for VS LED drivers

- Dimensioning automatic cut-outs: High transient currents occur when an LED driver is switched on because the capacitors have to load. Ignition of LED modules occurs almost simultaneously. This also causes a simultaneous high demand for power. These high currents when the system is switched on put a strain on the automatic conductor cut-outs, which must be selected and dimensioned to suit.
- Release reaction: The release reaction of the automatic conductor cut-outs comply with VDE 0641, part 11, for B, C characteristics. The values shown in the following tables are for guidance purposes only and are subject to system-dependent change.
- No. of LED drivers: The maximum number of VS LED drivers applies to cases where the devices are switched on simultaneously. Specifications apply to single-pole fuses. The number of permissible drivers must be reduced by 20% for multi-pole fuses. The considered circuit impedance equals 400 mΩ (approx. 20 m [2.5 mm<sup>2</sup>] of conductor from the power supply to the distributor and a further 15 m to the luminaire).

Type	Ref. No.	Automatic cut-out type and possible no. of VS drivers pcs.		
<b>Automatic cut-out type B</b>				
		B 10 A	B 13 A	B 16 A
ECXd 1050.352	<b>186875</b>	23	29	36
ECXd 1050.353	<b>186876</b>	18	23	28
ECXd 1050.354	<b>186877</b>	8	10	12
ECXd 1050.355	<b>186878</b>	7	9	11
<b>Automatic cut-out type C</b>				
		C 10 A	C 13 A	C 16 A
ECXd 1050.352	<b>186875</b>	37	48	59
ECXd 1050.353	<b>186876</b>	30	39	48
ECXd 1050.354	<b>186877</b>	13	17	21
ECXd 1050.355	<b>186878</b>	11	15	18

- To limit capacitive inrush currents the current carrying capacity of each circuit breaker (fuse) can be increased by a factor of 2.5 with the help of our ESB (Ref. No.: 149820, 149821, 149822) inrush current limiters.

### EU compliance information

Hereby, Vossloh-Schwabe Deutschland GmbH declares that the radio equipment type Primeline NFC/LEDSet S-MD is in compliance with Directive 2014/53/EU.

The full text of the EU declaration of conformity is available at the following internet address: [www.vossloh-schwabe.com](http://www.vossloh-schwabe.com).

The values contained in this data sheet can change due to technical innovations. Any such changes will be made without separate notification.

## Choice of LEDSet Resistor

### Output current selection:

- The output current can be adapted within the rated output current range between 200 and 1050 mA
- To change the output current it is necessary to use the correct LEDSet resistor. Values for different currents are figured out in the table below.
- The LEDSet resistor should have a maximum tolerance of 1%.
- Please refer to the electrical values and the operating window to see which combinations are possible.
- Output current / needed LEDSet resistor can be calculated as follows:

$$I_{OUT} = 5V/R_{set} \times 1000$$

$$R_{set} = 5V/I_{OUT} \times 1000$$

- If no LEDSet resistor is mounted (delivery condition) output current is less than nominal  $I_{min}$ .
- If LEDSet interface is short circuit output current is limited to  $I_{max}$ .

Resistors		186875				186876				186877				186878			
Nominal current $I_{rated}$ (mA)	Resistor R kΩ	LED output voltage ( $U_{LED}$ )		LED nominal output ( $P_{rated}$ )		LED output voltage ( $U_{LED}$ )		LED nominal output ( $P_{rated}$ )		LED output voltage ( $U_{LED}$ )		LED nominal output ( $P_{rated}$ )		LED output voltage ( $U_{LED}$ )		LED nominal output ( $P_{rated}$ )	
		V min.	V max.	W min.	W max.	V min.	V max.	W min.	W max.	V min.	V max.	W min.	W max.	V min.	V max.	W min.	W max.
200	25.00	10	38	2	7.6	15	56	3	11.2	35	115	7	23	80	220	16	44
250	20.00	10	38	2.5	9.5	15	56	3.8	14	35	115	8.8	28.8	80	220	20	55
300	16.67	10	38	3	11.4	15	56	4.5	16.8	35	115	10.5	34.5	80	220	24	66
350	14.29	10	38	3.5	13.3	15	56	5.3	19.6	35	115	12.3	40.3	80	220	28	77
400	12.50	10	38	4	15.2	15	56	6	22.4	35	115	14	46	80	220	32	88
450	11.11	10	38	4.5	17.1	15	56	6.8	25.2	35	115	15.8	51.8	80	220	36	99
500	10.00	10	38	5	19	15	56	7.5	28	35	115	17.5	57.5	80	220	40	110
550	9.09	10	38	5.5	20.9	15	56	8.3	30.8	35	115	19.3	63.3	80	200	44	110
600	8.33	10	36.7	6	22	15	56	9	33.6	35	115	21	69	80	183.3	48	110
650	7.69	10	33.8	6.5	22	15	56	9.8	36.4	35	115	22.8	74.8	80	169.2	52	110
700	7.14	10	31.4	7	22	15	56	10.5	39.2	35	107.1	24.5	75	80	157.1	56	110
750	6.67	10	29.3	7.5	22	15	53.3	11.3	40	35	100	26.3	75	80	146.7	60	110
800	6.25	10	27.5	8	22	15	50	12	40	35	93.8	28	75	80	137.5	64	110
850	5.88	10	25.9	8.5	22	15	47.1	12.8	40	35	88.2	29.8	75	80	129.4	68	110
900	5.56	10	24.4	9	22	15	44.4	13.5	40	35	83.3	31.5	75	80	122.2	72	110
950	5.26	10	23.2	9.5	22	15	42.1	14.3	40	35	78.9	33.3	75	80	115.8	76	110
1000	5.00	10	22	10	22	15	40	15	40	35	75	35	75	80	110	80	110
1050	4.76	10	21	10.5	22	15	38.1	15.8	40	35	71.4	36.8	75	80	104.8	84	110

The values contained in this data sheet can change due to technical innovations. Any such changes will be made without separate notification.