

EFM50-0KF0A023A

EFS/EFM50

MOTOR FEEDBACK SYSTEMS ROTARY HIPERFACE DSL®

SICK
Sensor Intelligence.

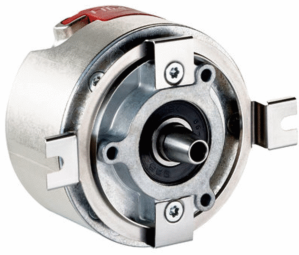

Ordering information

Type	Part no.
EFM50-0KF0A023A	1073502

Other models and accessories → www.sick.com/EFM50

Illustration may differ



Detailed technical data

Safety-related parameters

Test rate	1 h
------------------	-----

Performance

Position	Resolution per revolution	23 bit
	System accuracy	± 50 "
	Signal noise (σ)	± 2 "
	Number of the absolute ascertainable revolutions	4,096
	Available memory area	8,192 Byte
	Measurement step per revolution	8,388,608
Vibration	Measurement principle	Optical

Interfaces

Code sequence	Increasing, when turning the shaft For clockwise rotation, looking in direction "A" (see dimensional drawing)
Communication interface	HIPERFACE DSL®
Initialization time	Max. 500 ms ¹⁾
Measurement external temperature resistance	32-bit value, without prefix (1 Ω) 0 ... 209.600 Ω ²⁾

¹⁾ From reaching a permitted operating voltage.

²⁾ Without sensor tolerance; at -17 °C ... +167 °C: NTC +2K (103 GT); PTC+3K (KTY84/130/PT1000).

Electrical data

Connection type	Male connector, 4-pin
Supply voltage	7 V ... 12 V

¹⁾ Duration of the voltage ramp between 0 and 7.0 V, see diagram "Current consumption" in the diagram section.

²⁾ Current rating applies when using interface circuit suggestions as shown in HIPERFACE DSL® manual (8017595).

³⁾ This product is a standard product and does not constitute a safety component as defined in the Machinery Directive. Calculation based on nominal load of components, average ambient temperature 60 °C, frequency of use 8760 h/a. All electronic failures are considered hazardous. For more information, see document no. 8015532.

Warm-up time voltage ramp	Max. 180 ms ¹⁾
Current consumption	≤ 150 mA ²⁾
Output frequency for the digital position value	0 kHz ... 75 kHz
MTTF: mean time to dangerous failure	145 years (EN ISO 13849) ³⁾

¹⁾ Duration of the voltage ramp between 0 and 7.0 V, see diagram "Current consumption" in the diagram section.

²⁾ Current rating applies when using interface circuit suggestions as shown in HIPERFACE DSL® manual (8017595).

³⁾ This product is a standard product and does not constitute a safety component as defined in the Machinery Directive. Calculation based on nominal load of components, average ambient temperature 60 °C, frequency of use 8760 h/a. All electronic failures are considered hazardous. For more information, see document no. 8015532.

Mechanical data

Shaft version	Tapered shaft
Flange type / stator coupling	Stator coupling
Dimensions	See dimensional drawing
Weight	0.2 kg
Moment of inertia of the rotor	10 gcm ²
Operating speed	≤ 9,000 min ⁻¹
Angular acceleration	≤ 200,000 rad/s ²
Start up torque	≤ 0.4 Ncm
Permissible radial shaft movement	± 0.2 mm ¹⁾
Permissible axial shaft movement	± 0.95 mm
Permissible movement static	± 0.1 mm, ± 0.95 mm radial, axial
Permissible movement dynamic	± 0.05 mm radial
Life of ball bearings	See diagram 3

¹⁾ Permitted when using the elastomer stator coupling. When the spring plate stator coupling is being used, voltage-free mounting is assumed.

Ambient data

Operating temperature range	-30 °C ... +120 °C ¹⁾
Storage temperature range	-40 °C ... +120 °C, without package
Relative humidity/condensation	90 %, Condensation not permitted
Resistance to shocks	100 g, 6 ms, 6 ms (according to EN 60068-2-27)
Frequency range of resistance to vibrations	20 g, 10 Hz ... 2,000 Hz (EN 60068-2-6)
EMC	According to EN 61000-6-2, EN 61000-6-3 and IEC 61326-3-1 ²⁾
Enclosure rating	IP40, with mating connector inserted and closed cover (IEC 60529-1)

¹⁾ The max. internal sensor temperature may not exceed 125 °C. The defined measuring point on the encoder (see dimensional drawing) must be used for measuring the operating temperature. For typical values for self-heating, see diagram 3 (electrical) and diagram 4 (mechanical).

²⁾ EMC according to the listed standards is guaranteed if the motor feedback system with mating plug inserted is connected to the central grounding point of the motor controller via a cable shield. If other screening concepts are used, users must perform their own tests.

Classifications

ECLASS 5.0	27270590
ECLASS 5.1.4	27270590
ECLASS 6.0	27270590
ECLASS 6.2	27270590

ECLASS 7.0	27270590
ECLASS 8.0	27270590
ECLASS 8.1	27270590
ECLASS 9.0	27270590
ECLASS 10.0	27273805
ECLASS 11.0	27273901
ECLASS 12.0	27273901
ETIM 5.0	EC001486
ETIM 6.0	EC001486
ETIM 7.0	EC001486
ETIM 8.0	EC001486
UNSPSC 16.0901	41112113

Dimensional drawing (Dimensions in mm (inch))

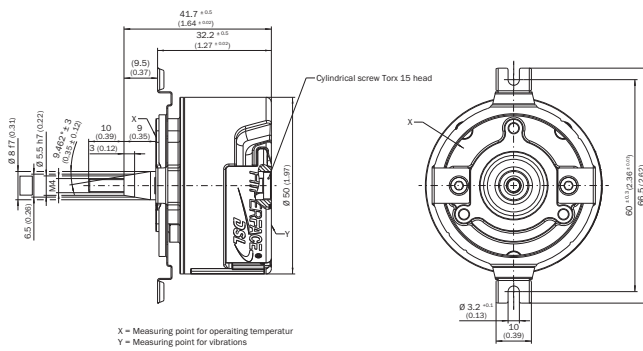

PIN assignment

Supply / Communication pin assignment

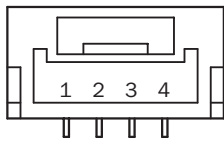

Integrated in motor cable = J, K

PIN	Signal	Explanation
1		Not connected - no function
2	+U _S /DSL+	Supply 7 V ... 12 V
3	GND/DSL-	Ground connection
4		Not connected - no function
Recommended outer diameter of set of stranded wires: 4 mm +0/-0.3 mm		
Recommended mating connector: JST (GHR-04V-S)		

Temperature sensor pin assignment

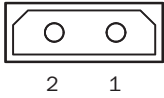

PIN	Signal	Explanation
1	T+	Thermistor connection
2	T-	Thermistor connection (to ground)
Recommended outer diameter of set of stranded wires: 2.2 mm ± 0.1 mm		
Recommended mating connector: Harwin M80-8990205		

Diagrams

Electrical self-heating

Diagram 3

Typ. mechanical self-heating, kelvin (K)

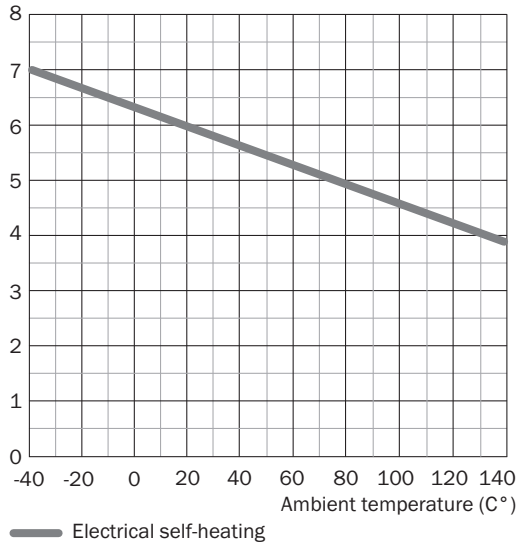

Power consumption

Diagram 2

Typ. current consumption (A)

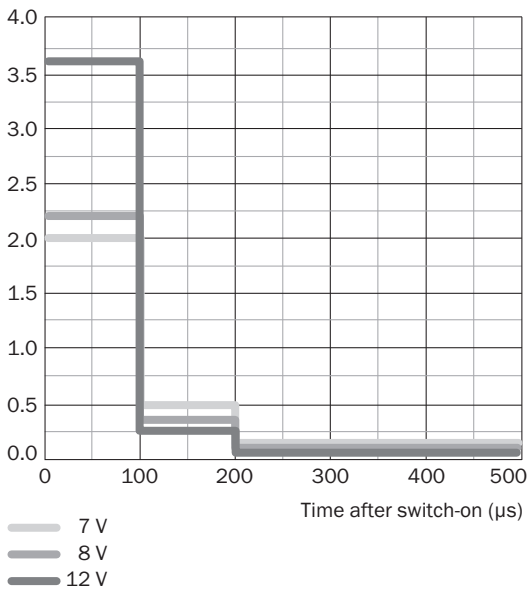

This diagram shows the switch-on current
Mechanical self-heating

Diagram 4

Typ. mechanical self-heating, kelvin (K)

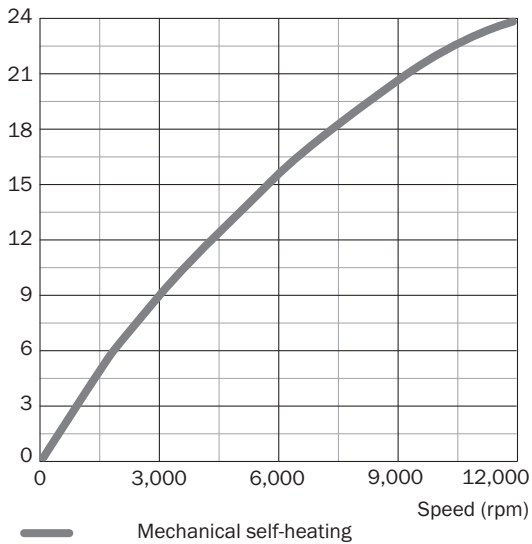

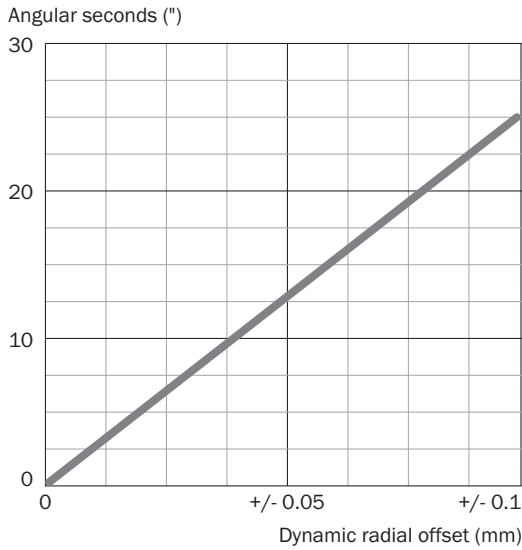

Error limits

Diagram 1



Recommended accessories

Other models and accessories → www.sick.com/EFS_EFM50

	Brief description	Type	Part no.
Other mounting accessories			
	Servo clamps, small, for servo flange (clamps, eccentric fastener), 3 pcs, without mounting material, without mounting hardware	BEF-WK-RESOL	2039082
Plug connectors and cables			
	<ul style="list-style-type: none"> • Connection type head A: Female connector, stranded wire, 4-pin, straight • Connection type head B: Flying leads • Signal type: HIPERFACE DSL® • Cable: 0.2 m, 2-wire • Description: HIPERFACE DSL®, unshielded 	D0L-0B02-G0M2XC2	2079920
	<ul style="list-style-type: none"> • Connection type head A: Female connector, stranded wire, 4-pin, straight • Connection type head B: Flying leads • Signal type: HIPERFACE DSL® • Cable: 0.36 m, 2-wire • Description: HIPERFACE DSL®, twisted, shielded 	D0L-0B02-G0M3AC2	2108944

SICK AT A GLANCE

SICK is one of the leading manufacturers of intelligent sensors and sensor solutions for industrial applications. A unique range of products and services creates the perfect basis for controlling processes securely and efficiently, protecting individuals from accidents and preventing damage to the environment.

We have extensive experience in a wide range of industries and understand their processes and requirements. With intelligent sensors, we can deliver exactly what our customers need. In application centers in Europe, Asia and North America, system solutions are tested and optimized in accordance with customer specifications. All this makes us a reliable supplier and development partner.

Comprehensive services complete our offering: SICK LifeTime Services provide support throughout the machine life cycle and ensure safety and productivity.

For us, that is “Sensor Intelligence.”

WORLDWIDE PRESENCE:

Contacts and other locations –www.sick.com