

## PRESENTATION

*Référence produit : 595.0200 (CEINTURE SAILLIE XE2 MED)*

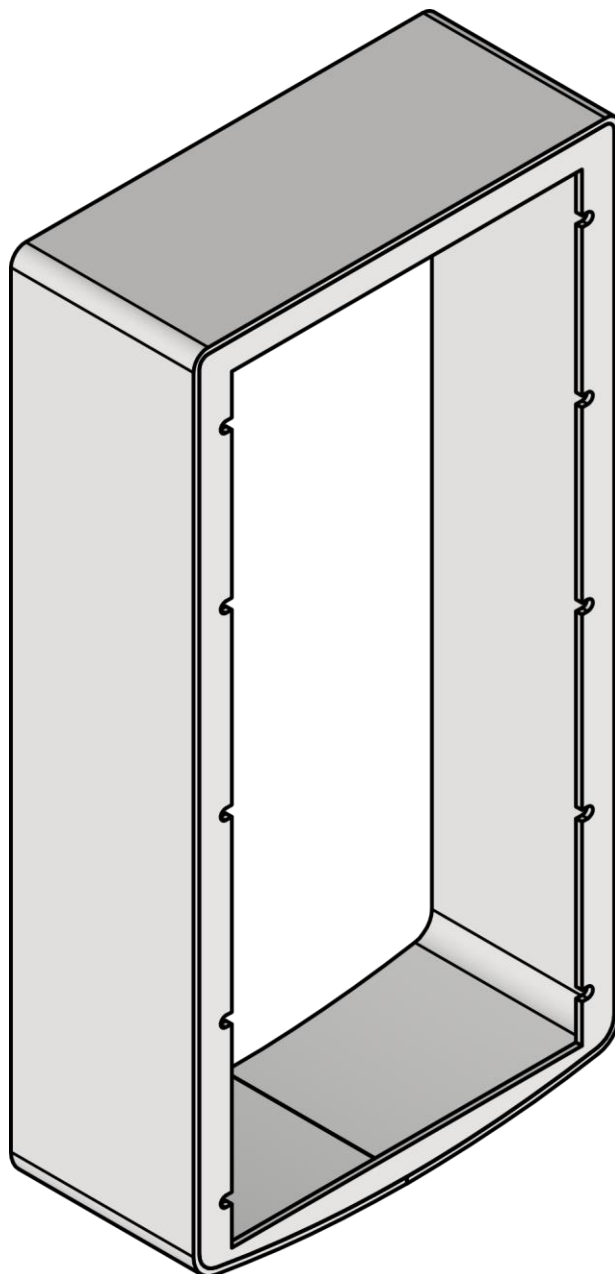

Matière : Inox 316L  
Epaisseur : 2mm

## ASSEMBLAGE

FR

La ceinture est prise en sandwich entre le fond et le cadre interface avec clipses de l'interphone. Utiliser les 10 vis du cadre pour verrouiller l'ensemble.

EN

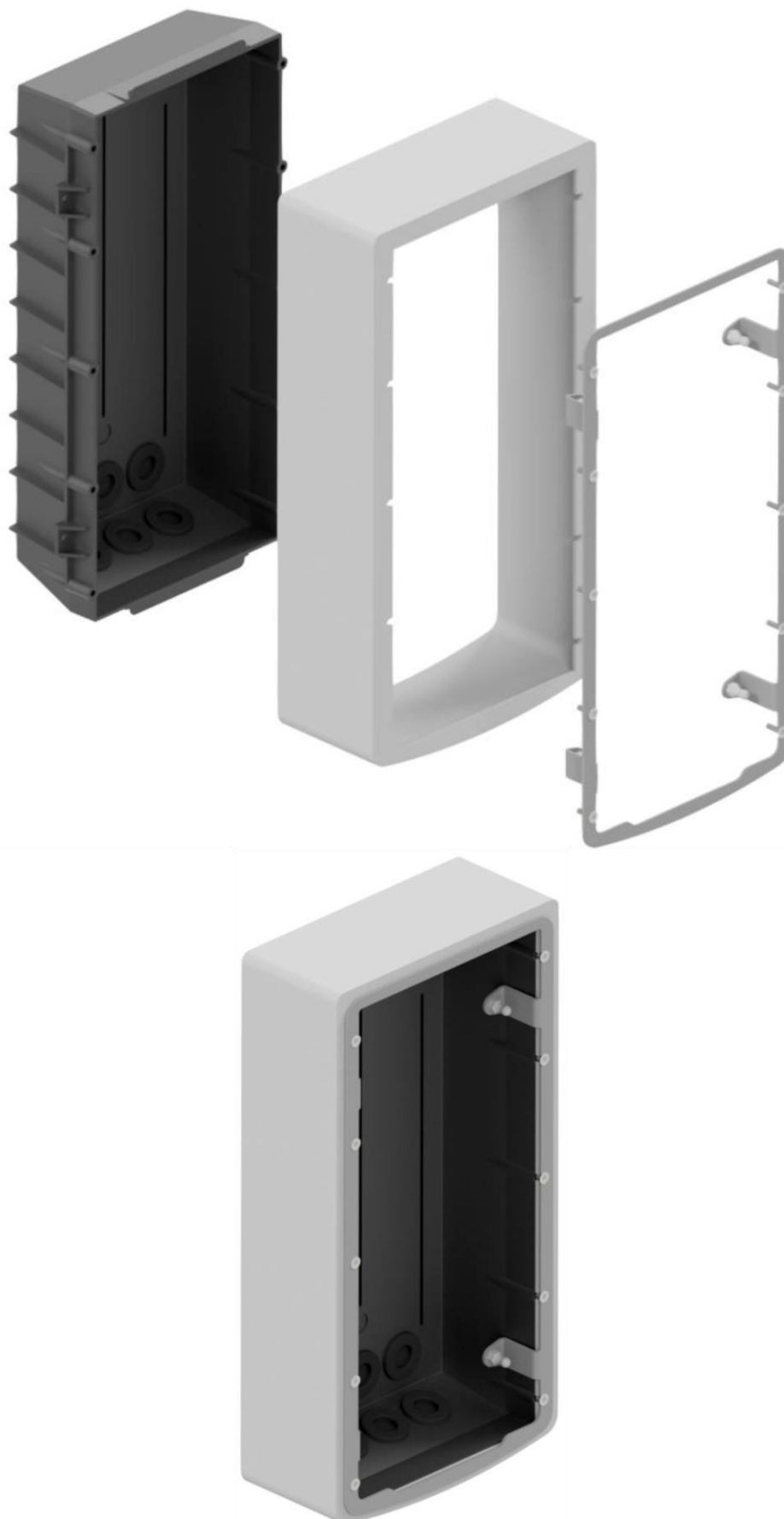

## DIMENSIONS

FR

EN

Percer 3 trous de fixations au diamètre souhaité dans le fond de l'interphone pour le fixer sur son support.

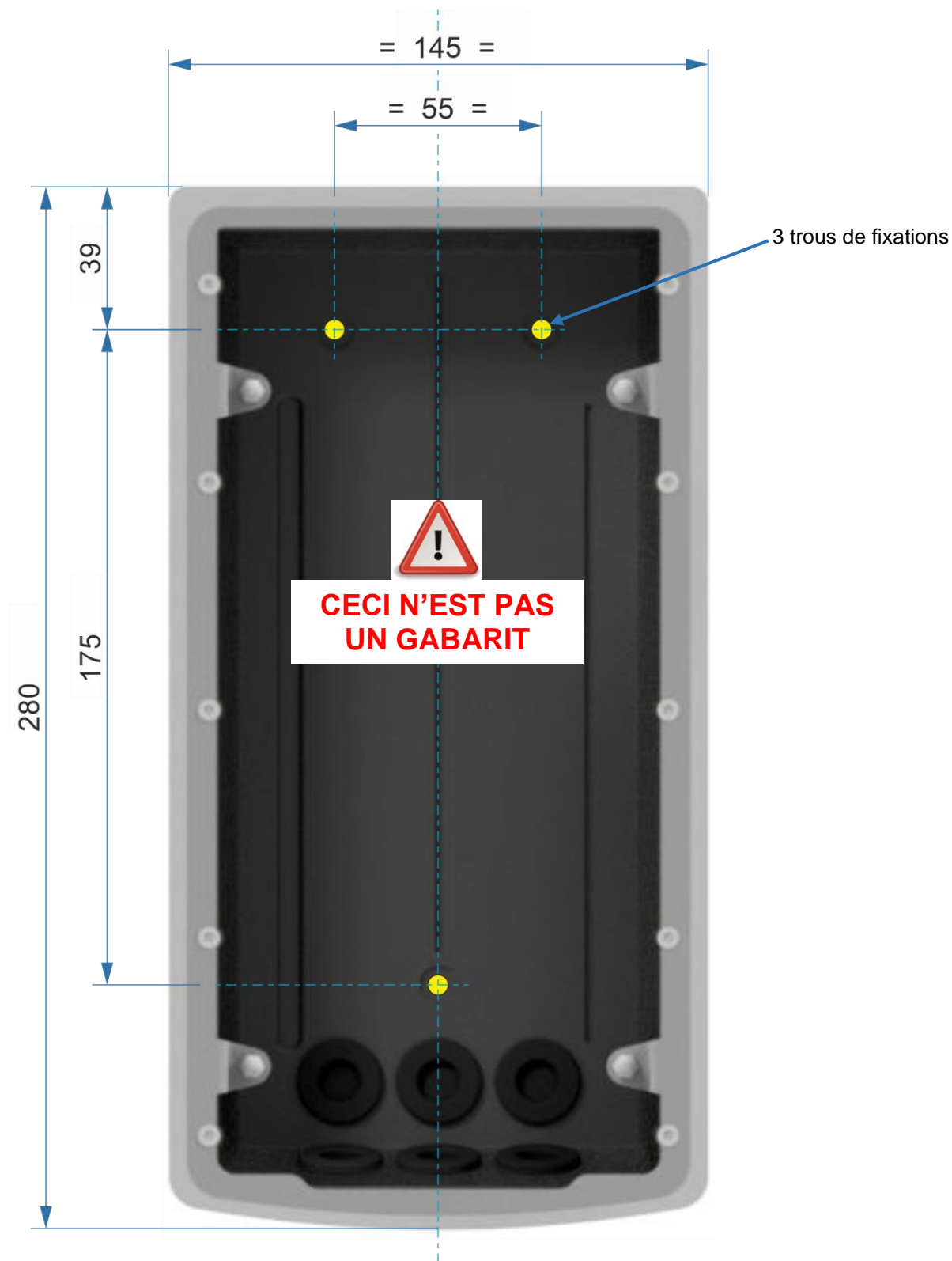

**Protection de l'environnement :**  
 Eliminez ce produit conformément aux règlements sur la préservation de l'environnement.

## PRESENTATION

*Product reference: 595.0200 (PROTRUDING BELT XE2 MED)*

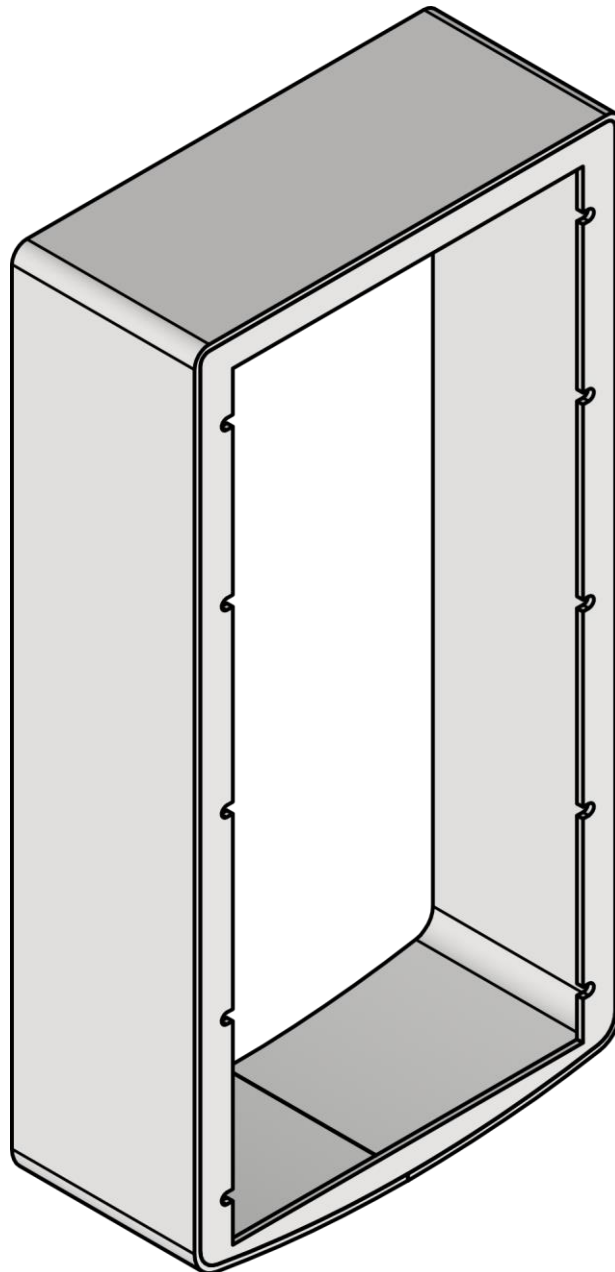

Matter : Stainless steel 316L  
Thickness : 2mm

## ASSEMBLY

FR

The belt is sandwiched between the base and the interface frame with intercom clips. Use the 10 screws on the frame to lock the assembly together.

EN

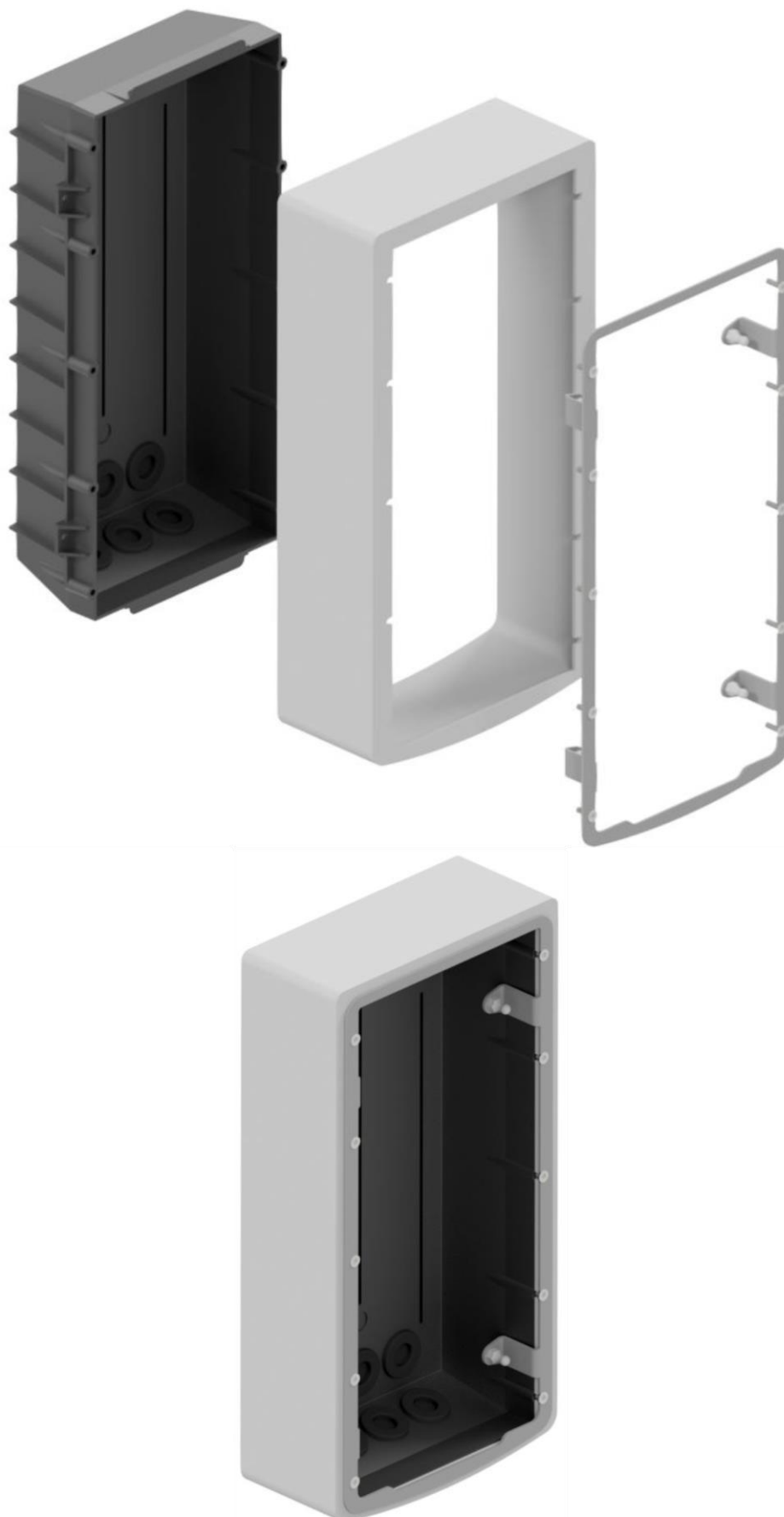

## DIMENSIONS

FR

Drill 3 fixing holes of the required diameter in the bottom of the intercom to fix it to the bracket.

EN

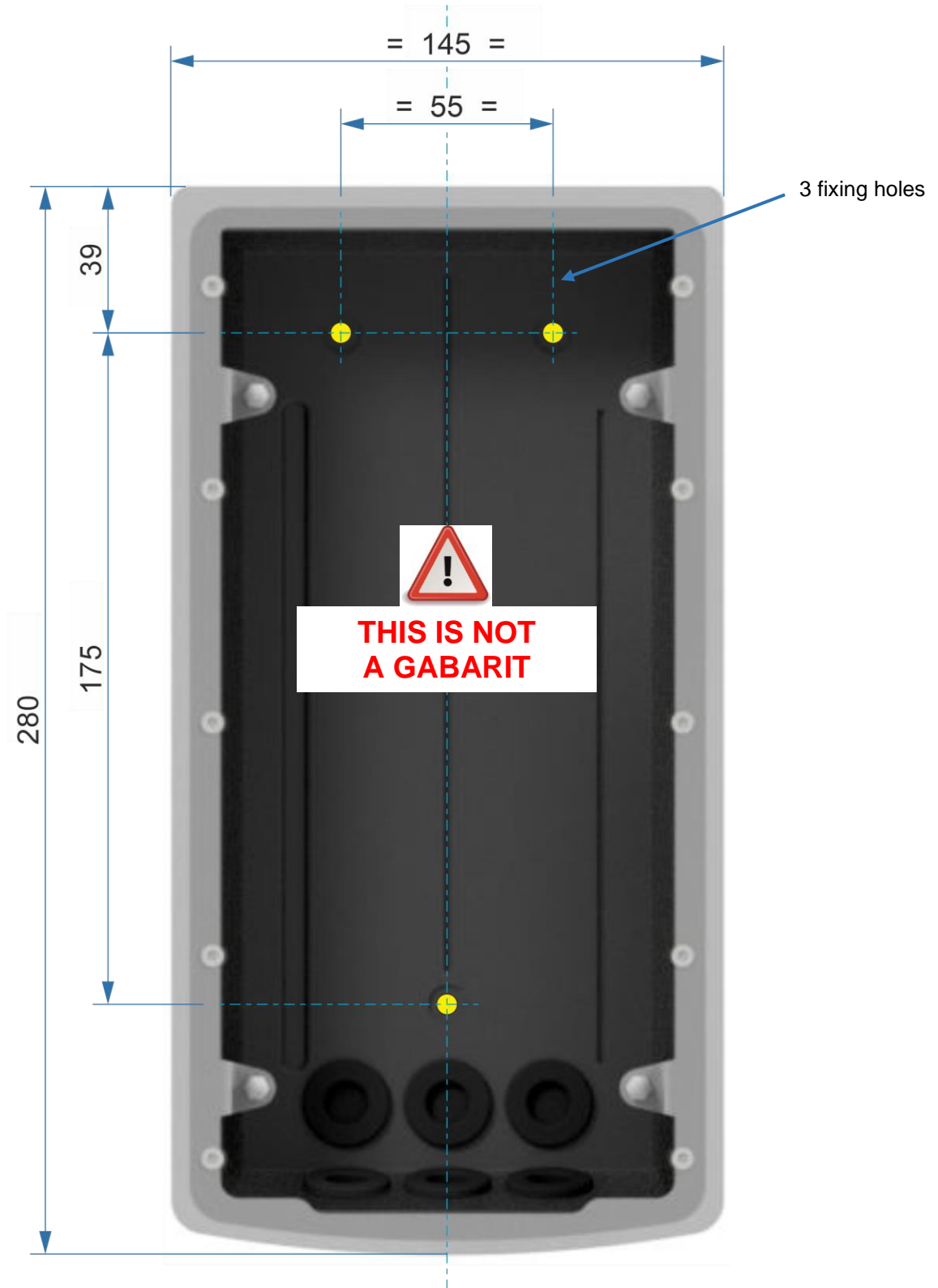

**Environmental protection:**

Dispose of this product in compliance with the environmental protection regulations.