

FX3-EBX100002

SICK
Sensor Intelligence.



Ordering information

Type	Part no.
FX3-EBX100002	2079867

Other models and accessories → www.sick.com/



Detailed technical data

Technical specifications

Accessory family	Connection modules
Description	Optimized motor feedback splitter box: facility for connecting two encoders/motor feedback systems. Connection to Motion Control Modules FX3-MOC: female connector, D-Sub HD, 15-pin.

Classifications

eCl@ss 5.0	27243092
eCl@ss 5.1.4	27243092
eCl@ss 6.0	27249204
eCl@ss 6.2	27249204
eCl@ss 7.0	27249204
eCl@ss 8.0	27249204
eCl@ss 8.1	27249204
eCl@ss 9.0	27243192
eCl@ss 10.0	27243192
eCl@ss 11.0	27243192
eCl@ss 12.0	27243192
ETIM 5.0	EC001604
ETIM 6.0	EC001604
ETIM 7.0	EC000474
ETIM 8.0	EC000474
UNSPSC 16.0901	32151705

Dimensional drawing (Dimensions in mm (inch))

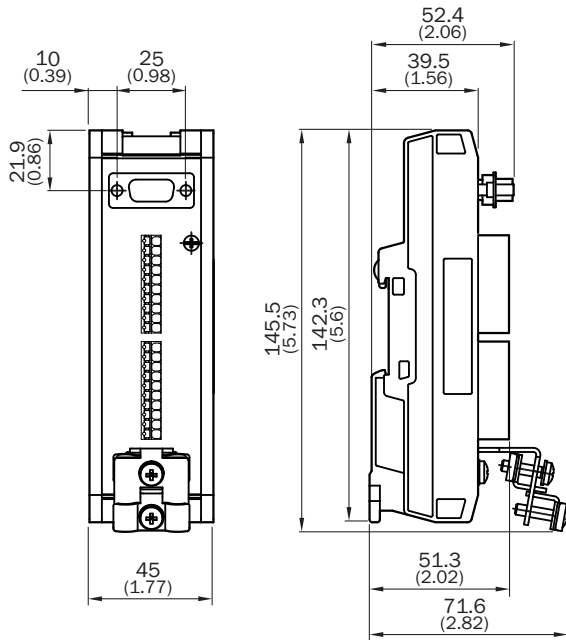

PIN assignment

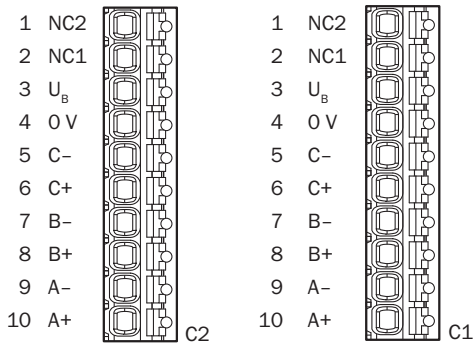

Spring terminals	PIN	Signal	Description
C1	1	NC2	Do not connect. Used to forward a signal.
	2	NC1	Do not connect. Used to forward a signal.
	3	ENC1_24V	24 V voltage supply for encoder 1
	4	ENC1_0V	GND encoder connection
	5	ENC1_C-	Encoder 1, channel C, negative signal
	6	ENC1_C+	Encoder 1, channel C, positive signal
	7	ENC1_B-	Encoder 1, channel B, negative signal

Spring terminals	PIN	Signal	Description
	8	ENC1_B+	Encoder 1, channel B, positive signal
	9	ENC1_A-	Encoder 1, channel A, negative signal
	10	ENC1_A+	Encoder 1, channel A, positive signal
C1	1	NC2	Do not connect. Used to forward a signal.
	2	NC1	Do not connect. Used to forward a signal.
	3	ENC2_24V	24 V voltage supply for encoder 2
	4	ENC2_0V	GND encoder connection
	5	ENC2_C-	Encoder 2, channel C, negative signal
	6	ENC2_C+	Encoder 2, channel C, positive signal
	7	ENC2_B-	Encoder 2, channel B, negative signal
	8	ENC2_B+	Encoder 2, channel B, positive signal
	9	ENC2_A-	Encoder 2, channel A, negative signal
	10	ENC2_A+	Encoder 2, channel A, positive signal

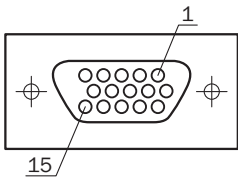

PIN	Signal	Description
1	ENC1_A+	Encoder 1, signal pair A, positive signal
2	ENC1_A-	Encoder 1, signal pair A, negative signal
3	ENC1_24V	24 V voltage supply for encoder 1
4	ENC2_A+	Encoder 2, signal pair A, positive signal
5	ENC2_A-	Encoder 2, signal pair A, negative signal
6	ENC1_B+	Encoder 1, signal pair B, positive signal
7	ENC1_B-	Encoder 1, signal pair B, negative signal
8	ENC_0V	0 V voltage supply for encoder 1 and encoder 2

PIN	Signal	Description
9	ENC2_B+	Encoder 2, signal pair B, positive signal
10	ENC2_B-	Encoder 2, signal pair B, negative signal
11	ENC1_C+	Encoder 1, signal pair C, positive signal
12	ENC1_C-	Encoder 1, signal pair C, negative signal
13	ENC2_24V	24 V voltage supply for encoder 2
14	ENC2_C+	Encoder 2, signal pair C, positive signal
15	ENC2_C-	Encoder 2, signal pair C, negative signal

SICK AT A GLANCE

SICK is one of the leading manufacturers of intelligent sensors and sensor solutions for industrial applications. A unique range of products and services creates the perfect basis for controlling processes securely and efficiently, protecting individuals from accidents and preventing damage to the environment.

We have extensive experience in a wide range of industries and understand their processes and requirements. With intelligent sensors, we can deliver exactly what our customers need. In application centers in Europe, Asia and North America, system solutions are tested and optimized in accordance with customer specifications. All this makes us a reliable supplier and development partner.

Comprehensive services complete our offering: SICK LifeTime Services provide support throughout the machine life cycle and ensure safety and productivity.

For us, that is “Sensor Intelligence.”

WORLDWIDE PRESENCE:

Contacts and other locations –www.sick.com