

- 1** Installation de la crosse sur le mur et passage du câble  
 Fix the bracket on the wall and engage the cable into the pipe

- 2** Engager le câble dans la lanterne  
 Engage the cable into the head

- 3** Visser la lanterne sur le raccord  
 Screw the luminaire on the socket

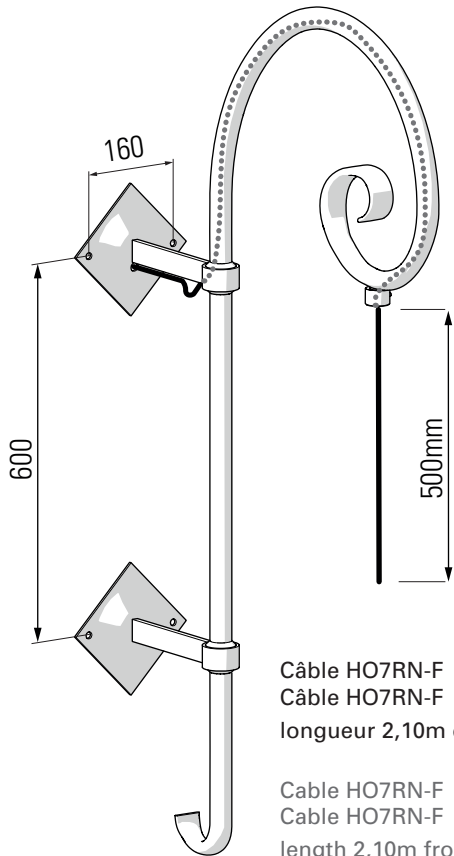

Câble HO7RN-F 3G1  
 Câble HO7RN-F 5G1 (pour pilotage 1-10Vdc)  
 longueur 2,10m en sortie du mur

Cable HO7RN-F 3G1  
 Cable HO7RN-F 5G1 (for dimmer 1-10Vdc)  
 length 2,10m from the wall

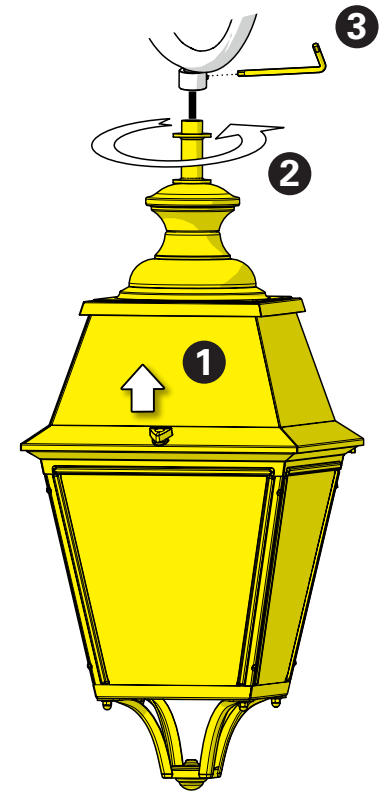
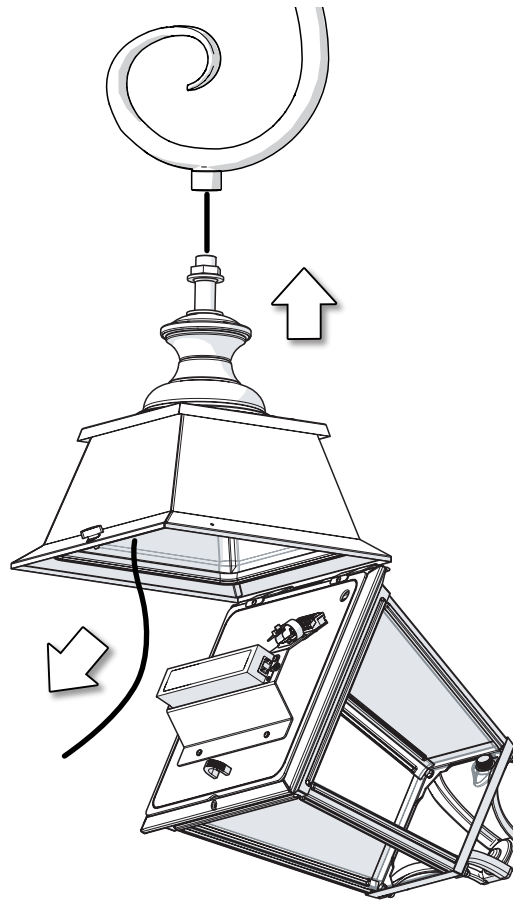

**4** Raccordement électrique  
Connect electrical wires

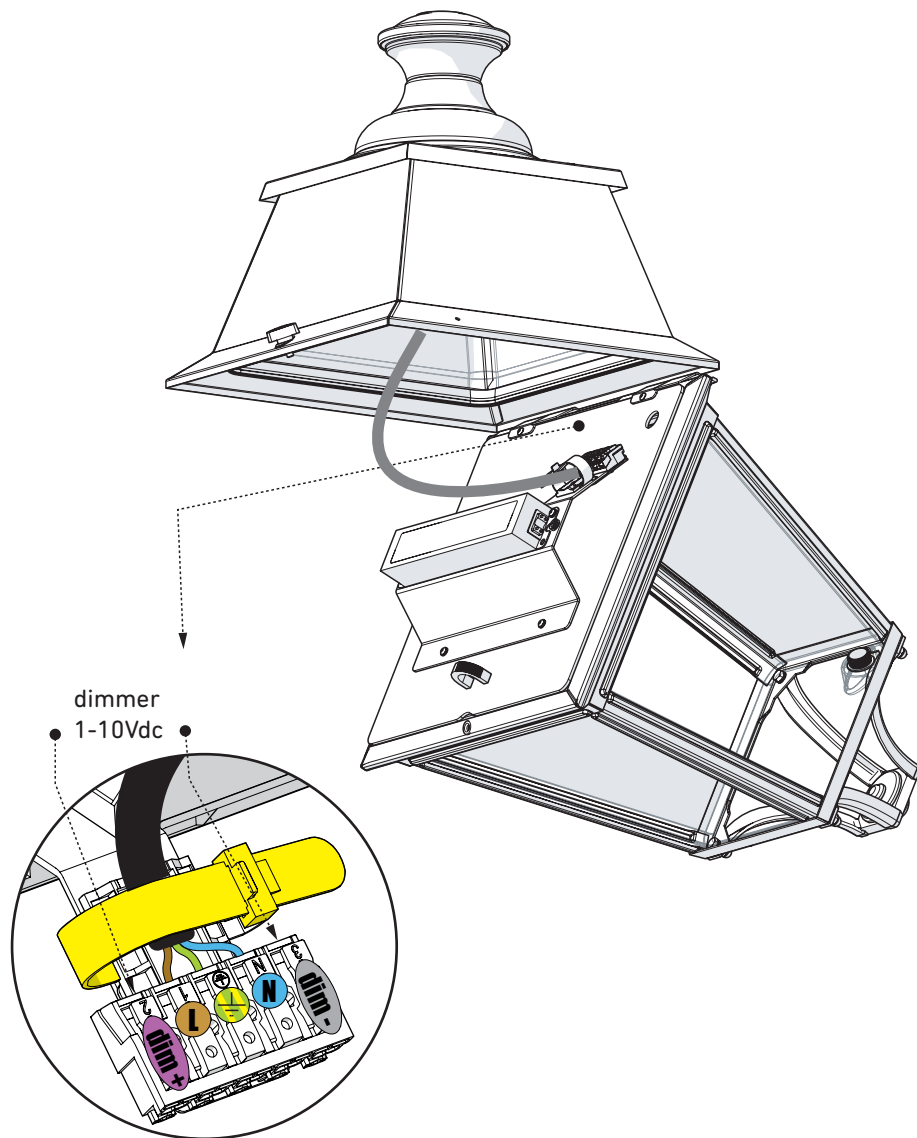

**5** Fermeture de la cage  
Close the cage

