

①

Percer le plafond.

Drill the ceiling.

 Perforar el techo.
Sujeta la bombilla en el zocalo.

②

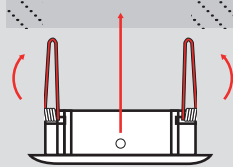
Relever les ailettes sur ressorts
Raise the fins on springs
Levantat las aletas sobre muelles

 Placer le **support dans le diamètre de perçage** du plafond

Place the support in the drilling diameter ceiling

Coloque el soporte en el diámetro de perforación techo

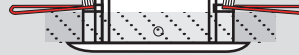
③

(Rabattre les ailettes)
au dessus du plafond

Dobra las alas por encima del techo

④

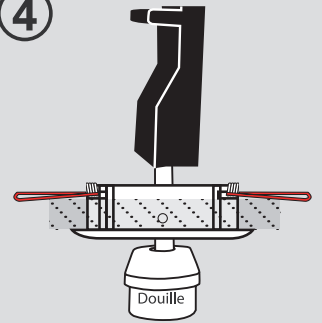
 Sortir la **douille du support de spot**

Take the socket out of the spot holder

Saque el enchufe del soporte del spot

⑤

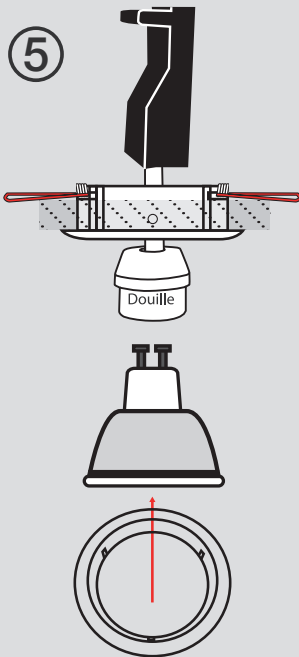
Clipser l'ampoule dans le support de spot

Clip the bulb into the spot holder

Clip de la bombilla en el soporte del foco

⑥

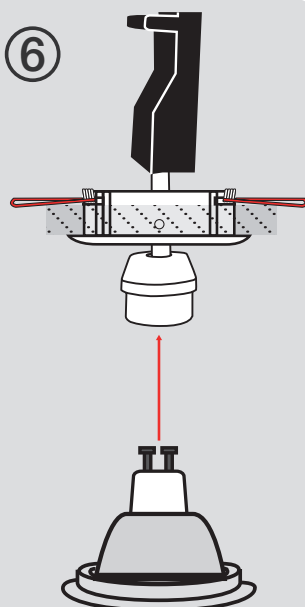
 Placer l'**ampoule avec le support de spot dans la douille**

Place the bulb with the spot holder in the socket

Coloque la bombilla con el portalámparas en el casquillo

⑦

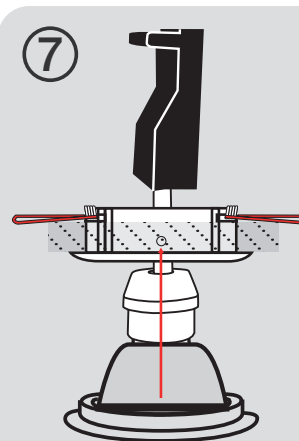
Clipser la collerette de fixation de l'ampoule au support

Clip the collar fixing the bulb to the support

Cortar el collar arreglando la bombilla al soporte

⑧

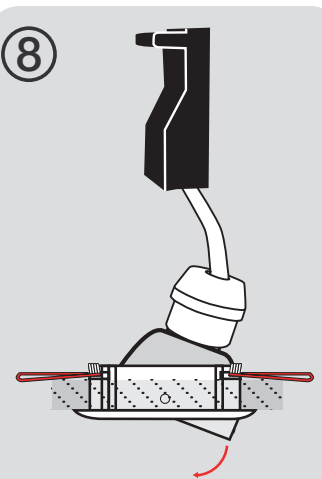
Éclairage inclinable

Lighting Tilt

Iluminación inclinación

①



Bucare il soffitto

Die Decke durchbohren

②

Solleva le alette delle molle

Heben Sie die Flossen an den Federn an

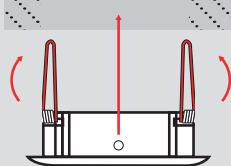

Posizionare il supporto nel diametro del foro del soffitto

Legen Sie die Stütze in den Lochdurchmesser der Decke

③

Piega le alette sopra il soffitto



Falten Sie die Lamellen über die Decke

④

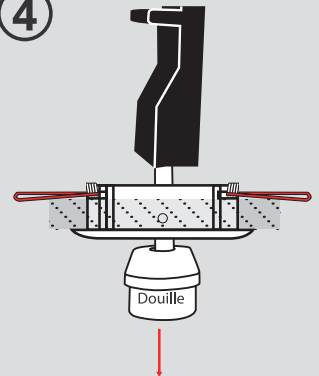

Estrarre la presa dal supporto spot

Nehmen Sie die Steckdose aus dem Spothalter

⑤

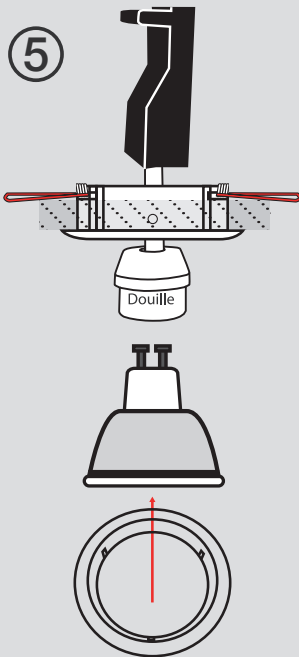

Aggancia la lampadina al portalampada

Stecken Sie die Glühlampe in den Spothalter

⑥

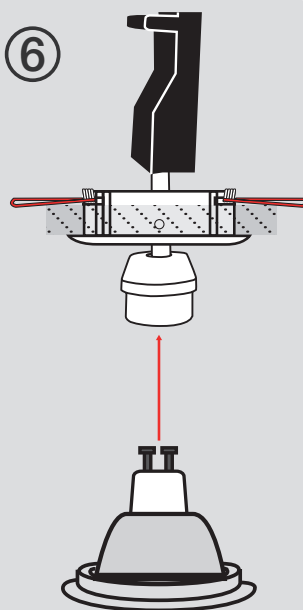

Posizionare la lampadina con il supporto spot nella presa

Setzen Sie die Glühbirne mit dem Spothalter in die Fassung ein

⑦

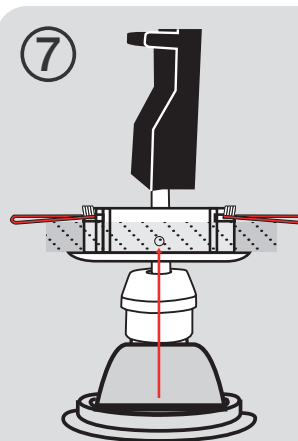

Agganciare il collare di fissaggio della lampadina al supporto

Befestigen Sie den Lampenbefestigungskragen an der Halterung

⑧

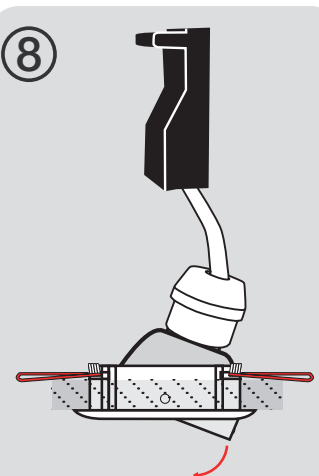

illuminazione basculante

kippende Beleuchtung