

# Altivar® 71W Adjustable Speed Drives Simplified Manual

0.75–75 kW (1–100 hp), 380–480 V, IP54

For use in the United States

Instruction Bulletin

30072-453-05

Retain for future use.





# Table of contents

Hazard categories and special symbols _____	4
Before you begin _____	5
Product support _____	5
Setting up the drive _____	6
Preliminary recommendations _____	7
Drive ratings _____	9
Dimensions and weights _____	10
Mounting recommendations _____	11
Opening the drive _____	11
Adding control operators on the front of the drive _____	12
Position of the LED indicating DC bus capacitors are charged _____	13
Wiring recommendations _____	14
Terminals _____	15
Connection diagrams _____	21
Operation on an IT or corner grounded delta system _____	24
Electromagnetic compatibility, wiring _____	25
Setup - preliminary recommendations _____	28
Graphic display terminal _____	29
[1.1 SIMPLY START] (SIM-) menu _____	31
Parameters that can be changed while the drive is running or stopped _____	35
Detected faults - causes - remedies _____	36

# Hazard categories and special symbols

Read these instructions carefully, and look at the equipment to become familiar with the device before trying to install, operate, or maintain it. The following special messages may appear throughout this documentation or on the equipment to warn of potential hazards or to call attention to information that clarifies or simplifies a procedure.



The addition of this symbol to a Danger or Warning safety label indicates that an electrical hazard exists, which will result in personal injury if the instructions are not followed.



This is the safety alert symbol. It is used to alert you to potential personal injury hazards. Obey all safety messages that follow this symbol to avoid possible injury or death.

## ▲ DANGER

**DANGER** indicates an imminently hazardous situation which, if not avoided, **will result in death** or serious injury.

## ▲ WARNING

**WARNING** indicates a potentially hazardous situation which, if not avoided, **can result in death** or serious injury.

## ▲ CAUTION

**CAUTION** indicates a potentially hazardous situation which, if not avoided, **can result in minor** or moderate injury.

## CAUTION

**CAUTION**, used without the safety alert symbol, indicates a potentially hazardous situation which, if not avoided, **can result in property damage**.

## Important Notes

Electrical equipment should be installed, operated, serviced, and maintained only by qualified personnel. No responsibility is assumed by Schneider Electric for any consequences arising out of the use of this material. © 2005–2009 Schneider Electric. All rights reserved.

The word "drive" as used in this guide refers to the controller portion of the adjustable speed drive as defined in the National Electrical Code (NEC).

The following standards are referenced in this manual:

EN 954-1: "Safety of machinery, safety related parts of control systems," year 2000, sections 1–7  
IEC 61508: "Functional safety of electrical/electronic/programmable electronic safety-related systems"  
IEC/EN 60204-1: "Safety of machinery—Electrical equipment of machines—Part 1: General requirements for electrical equipment on machines"  
IEC 60755: General requirements for residual current operated protective devices  
NFPA 79 Electrical standard for industrial machinery

# Before you begin

Read and understand these instructions before performing any procedure on this drive.

## ▲ DANGER

### HAZARD OF ELECTRIC SHOCK, EXPLOSION, OR ARC FLASH

- Read and understand this manual before installing or operating the Altivar 71 (ATV71) drive. Installation, adjustment, repair, and maintenance must be performed by qualified personnel.
- The user is responsible for compliance with all international and national electrical code requirements with respect to grounding of all equipment.
- Many parts of this drive, including the printed circuit boards, operate at the line voltage. **DO NOT TOUCH.** Use only electrically insulated tools.
- **DO NOT** touch unshielded components or terminal strip screw connections with voltage present.
- **DO NOT** short across terminals PA/+ and PC/- or across the DC bus capacitors.
- Before servicing the drive:
  - Disconnect all power, including external control power that may be present.
  - Place a "DO NOT TURN ON" label on all power disconnects.
  - Lock all power disconnects in the open position.
  - WAIT 15 MINUTES to allow the DC bus capacitors to discharge. Then follow the "Procedure for measuring the DC bus voltage" on page 13 to verify that the DC voltage is less than 42 V. The drive LED is not an indicator of the absence of DC bus voltage.
- Install and close all covers before applying power or starting and stopping the drive.

**Failure to follow these instructions will result in death or serious injury.**

## ▲ WARNING

### LOSS OF CONTROL

- The designer of any control scheme must consider the potential failure modes of control paths and, for certain critical control functions, provide a means to achieve a safe state during and after a path failure. Examples of critical control functions are emergency stop and overtravel stop.
- Separate or redundant control paths must be provided for critical control functions.
- System control paths may include communication links. Consideration must be given to the implications of unanticipated transmission delays or failures of the link.<sup>1</sup>
- Each implementation of an Altivar 71 drive must be individually and thoroughly tested for proper operation before being placed into service.

**Failure to follow these instructions can result in death, serious injury, or equipment damage.**

1. For additional information refer to NEMA ICS 1.1 (latest edition), "Safety Guidelines for the Application, Installation, and Maintenance of Solid State Control" and to NEMA ICS 7.1 (latest edition), "Safety Standards for Construction and Guide for Selection, Installation and Operation of Adjustable-Speed Drive Systems."

## ▲ CAUTION

### IMPROPER DRIVE OPERATION

- If no power is applied to the drive for a long period, the performance of its electrolytic capacitors will be reduced.
- If the drive is not in active service, apply power to the drive every two years using the following procedure. Do not initially connect the drive directly to full line voltage. Without a motor connected to the drive, gradually increase the voltage using an adjustable AC source connected between drive terminals L1 and L2:
  - 25% of rated voltage for 30 minutes
  - 50% of rated voltage for 30 minutes
  - 75% of rated voltage for 30 minutes
  - 100% of rated voltage for at least 5 hours
- Check drive operation before placing the drive into service.

**Failure to follow these instructions can result in injury or equipment damage.**

## Product Support

For support and assistance, contact the Product Support Group. The Product Support Group is staffed from Monday through Friday, 8:00 am until 6:00 pm Eastern time, to assist with product selection, start-up, and diagnosis of product or application problems. Emergency phone support is available 24 hours a day, 365 days a year.

Toll free: 888-SquareD (888-778-2733)  
E-Mail: [drive.products.support@us.schneider-electric.com](mailto:drive.products.support@us.schneider-electric.com)  
Fax: 919-217-6508

# Setting up the drive

## ■ 1 Take delivery of the drive

- Ensure that the catalog number printed on the label is the same as that on the purchase order.
- Remove the drive from its packaging and ensure that it has not been damaged in transit.

## ■ 2 Check the line voltage

- Ensure that the line voltage is compatible with the voltage range of the drive.

## ■ 3 Mount the drive (page 11)

- Mount the drive in accordance with the instructions in this document.
- Install any internal and external options.

## ■ 4 Wire the drive (page 14)

- Connect the motor, ensuring that its connections correspond to the voltage.
- Connect the line supply, after making sure that the power is off.
- Connect the control wiring.
- Connect the speed reference.

**Steps 1 to 4 must be performed with the power off**



**Note: Ensure that the drive wiring is compatible with its configuration.**

## ■ 5 Power up without run command

- If you are using a separate power supply for the control section, follow the instructions on page 8.

## ■ 6 Select the language, (page 30) if the drive has a graphic display terminal

## ■ 7 Configure the [SIMPLY START] (5 / 7 -) menu (page 31)

- 2-wire or 3-wire control
- Macro configuration
- Motor parameters

### Optimize performance

To optimize performance, refer to the auto-tuning section on page 34.

- Motor thermal current
- Acceleration and deceleration ramps
- Speed variation range

## ■ 8 Start

# Preliminary recommendations

## Handling and storage

To protect the drive prior to installation, handle and store the device in its packaging. Ensure that the ambient conditions are acceptable. Refer to Dimensions and weights on page 10.

### ▲ WARNING

#### DAMAGED PACKAGING

If the packaging appears damaged, it can be hazardous to open and handle it. Do not handle or open a damaged package.

**Failure to follow these instructions can result in death or serious injury.**

### ▲ WARNING

#### DAMAGED DRIVE EQUIPMENT

Do not operate or install any drive that appears damaged.

**Failure to follow these instructions can result in death or serious injury.**

## Handling on installation

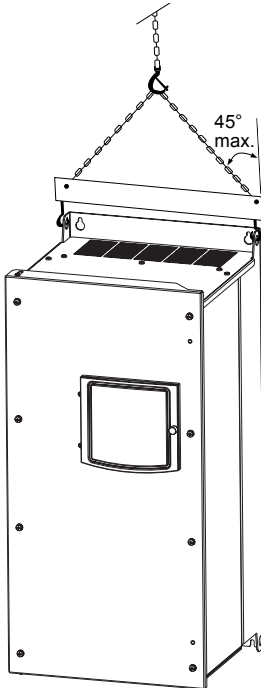

A hoist must be used with Altivar 71W drives; for this reason the drives are fitted with handling lugs. Attach a spreader bar to the top handling lugs on the drive.

### ▲ WARNING

#### RISK OF TOPPLING

Do not stand the drive upright. Keep the drive on the pallet until it is installed.

**Failure to follow these instructions can result in death or serious injury.**

# Preliminary recommendations

## Precautions

### CAUTION

#### INCOMPATIBLE LINE VOLTAGE

Before turning on and configuring the drive, ensure that the line voltage is compatible with the supply voltage range shown on the drive nameplate. The drive may be damaged if the line voltage is not compatible.

**Failure to follow these instructions can result in equipment damage.**

## Separate control section power supply

If the drive's control section is powered independently of the power section (P24 and 0 V terminals), when you add or replace an option card you must supply only the power section the next time the drive is powered up. Otherwise, the drive will not recognize the new card and it will be impossible to configure it. This will cause the drive to lock in the detected fault mode.

### ▲ DANGER

#### UNINTENDED EQUIPMENT OPERATION

- Before turning on and configuring the Altivar 71 drive, ensure that the PWR (POWER REMOVAL) input is deactivated (at state 0) in order to help prevent unintended operation.
- Before turning the drive on or upon exiting the configuration menus, ensure that the inputs assigned to the run command are deactivated (at state 0) since they can cause the motor to start immediately.
- Refer to the characteristics and functions table in the Control Terminals section beginning on page 18 for more information about the Power Removal Input.

**Failure to follow these instructions will result in death or serious injury.**



The Power Removal function takes priority over any run command. For use as an emergency stop, this function requires the use of connection diagrams conforming to standard EN 954-1 category 3, "Safety of machinery, Safety related parts of control systems," and safety integrity level 2 according to IEC 61508, "Functional safety of electrical/electronic/programmable electronic safety-related systems." Consult the *ATV71 Installation Manual* on the CD-ROM supplied with the drive.



# Drive ratings

## ATV71W - Three-phase supply voltage: 380...480 V 50/60 Hz

3-phase motor 380...480 V

Motor		Line supply					Drive			Altivar 71W
Power indicated on plate (1)		Max. line current (2)		Maximum prospective line Isc	Apparent power	Max. inrush current (3)	Max. available nominal current In (1)	Max. transient current for (1)		Catalog number (4) (5)
		380 V	480 V					60 s	2 s	
kW	HP	A	A	kA	kVA	A	A	A	A	
0.75	1	3.7	3	5	2.4	19.2	2.3	3.5	3.8	ATV71W075N4
1.5	2	5.8	5.3	5	4.1	19.2	4.1	6.2	6.8	ATV71WU15N4
2.2	3	8.2	7.1	5	5.6	19.2	5.8	8.7	9.6	ATV71WU22N4
3	–	10.7	9	5	7.2	19.2	7.8	11.7	12.9	ATV71WU30N4
4	5	14.1	11.5	5	9.4	19.2	10.5	15.8	17.3	ATV71WU40N4
5.5	7.5	20.3	17	22	13.7	46.7	14.3	21.5	23.6	ATV71WU55N4
7.5	10	27	22.2	22	18.1	46.7	17.6	26.4	29	ATV71WU75N4
11	15	36.6	30	22	24.5	93.4	27.7	41.6	45.7	ATV71WD11N4
15	20	48	39	22	32	93.4	33	49.5	54.5	ATV71WD15N4
18.5	25	45.5	37.5	22	30.5	93.4	41	61.5	67.7	ATV71WD18N4
22	30	50	42	22	33	75	48	72	79.2	ATV71WD22N4
30	40	66	56	22	44.7	90	66	99	109	ATV71WD30N4
37	50	84	69	22	55.7	90	79	118.5	130	ATV71WD37N4
45	60	104	85	22	62.7	200	94	141	155	ATV71WD45N4
55	75	120	101	22	81.8	200	116	174	191	ATV71WD55N4
75	100	167	137	22	110	200	160	240	264	ATV71WD75N4

(1) These power ratings and currents are given for an ambient temperature of 50°C (122 °F) at the factory-set switching frequency, used in continuous operation (factory-set switching frequency of 4 kHz for ATV71W 075N4 to D30N4 and 2.5 kHz for ATV71W D37N4 to D75N4).

Above this factory setting, the drive will reduce the switching frequency automatically in the event of excessive temperature rise. For continuous operation above the rated switching frequency, derate the rated drive current (see the derating curves in our catalog).

(2) Current for the given motor power on a line supply with the "Max. prospective line Isc" indicated and for a drive without any external options.

(3) Peak current on power-up for the max. voltage (480 V +10%).

(4) These drives can be ordered with a 24 V  $\bar{\bar{=}}$  power supply, allowing an additional consumption of 250 mA. In this case, add A24 at the end of the catalog number.

For example, ATV 71W075N4 becomes **ATV 71W075N4A24**.

(5) ATV71●●●N4: In the U.S., this is a UL Type 12 drive (connection plate for compliance with UL Type 12).

# Dimensions and weights

## ATV71W

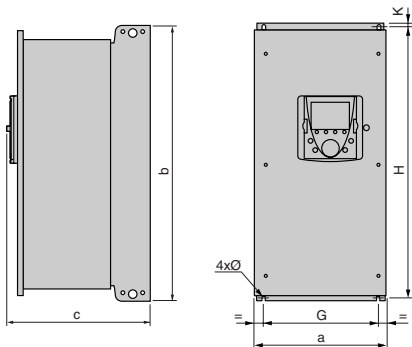

ATV71W	a mm (in.)	b mm (in.)	c mm (in.)	G mm (in.)	H mm (in.)	K mm (in.)	Ø mm (in.)	Weight kg (lb.)
<b>075N4</b> <b>U15N4</b> <b>U22N4</b>	240 (9.45)	490 (19.29)	272 (10.71)	200 (7.87)	476 (18.74)	6 (0.23)	6 (0.23)	12 (27)
<b>U30N4</b> <b>U40N4</b>	240 (9.45)	490 (19.29)	286 (11.26)	200 (7.87)	476 (18.74)	6 (0.23)	6 (0.23)	13 (29)
<b>U55N4</b> <b>U75N4</b>	260 (10.24)	525 (20.67)	286 (11.26)	220 (8.66)	511 (20.12)	6 (0.23)	6 (0.23)	16 (36)
<b>D11N4</b>	295 (11.61)	560 (22.05)	315 (12.40)	250 (9.84)	544 (21.42)	8 (0.31)	6 (0.23)	21 (47)
<b>D15N4</b> <b>D18N4</b>	315 (12.40)	665 (26.18)	315 (12.40)	270 (10.63)	647 (25.47)	10 (0.39)	6 (0.23)	31 (69)
<b>D22N4</b>	285 (11.22)	720 (28.35)	315 (12.40)	245 (9.65)	700 (27.56)	10 (0.39)	7 (0.28)	34 (75)
<b>D30N4</b> <b>D37N4</b>	285 (11.22)	880 (34.65)	343 (13.50)	245 (9.65)	860 (33.86)	10 (0.39)	7 (0.28)	43 (95)
<b>D45N4</b> <b>D55N4</b> <b>D75N4</b>	362 (14.25)	1000 (39.37)	364 (14.33)	300 (11.81)	975 (38.39)	10 (0.39)	9 (0.35)	69 (152)

# Mounting recommendations

Depending on the conditions in which the drive is to be used, its installation will require certain precautions and the use of appropriate accessories.

- Install the drive vertically,  $\pm 10^\circ$ .
- Do not place it close to heating elements.
- Leave sufficient free space to ensure that the air required for cooling purposes can circulate from the bottom to the top of the unit.
- Maximum operating temperature is 50 °C. For derating curves based on ambient temperatures greater than 50 °C and for switching frequencies, see our catalog.

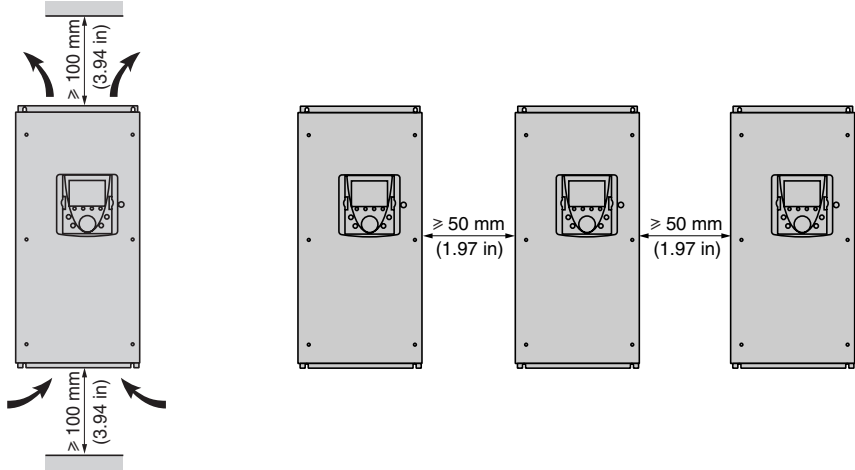

## Opening the drive

To open the drive, remove the front panel and disconnect the graphic display terminal's connection cable as shown below:

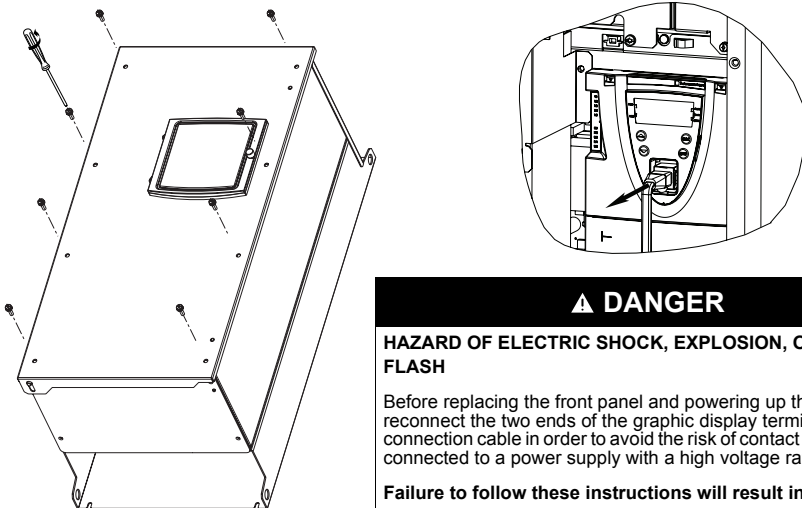

### **▲ DANGER**

#### **HAZARD OF ELECTRIC SHOCK, EXPLOSION, OR ARC FLASH**

Before replacing the front panel and powering up the drive, reconnect the two ends of the graphic display terminal's connection cable in order to avoid the risk of contact with a device connected to a power supply with a high voltage rating.

**Failure to follow these instructions will result in death or serious injury.**

# Adding control operators on the front of the drive

One or two 22 mm diameter control operators can be added on the front of the drive. These units must be positioned as shown in the diagram and table below.

## ⚠ DANGER

### HAZARD OF ELECTRIC SHOCK, EXPLOSION, OR ARC FLASH

Ensure that there is sufficient clearance between any added equipment and the drive when the front of the drive is closed.

**Failure to follow these instructions will result in death or serious injury.**

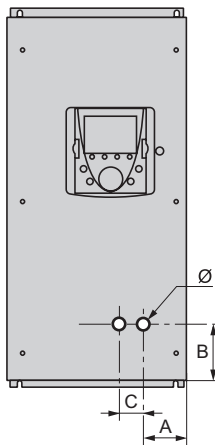

ATV71W	A mm (in.)	B mm (in.)	C mm (in.)	Ø mm (in.)
<b>075N4</b> <b>U15N4</b> <b>U22N4</b>	60.5 (2.38)	80 (3.15)	30 (1.18)	22.3 (0.88)
<b>U30N4</b> <b>U40N4</b>	60.5 (2.38)	80 (3.15)	30 (1.18)	22.3 (0.88)
<b>U55N4</b> <b>U75N4</b>	60.5 (2.38)	80 (3.15)	30 (1.18)	22.3 (0.88)
<b>D11N4</b>	77 (3.03)	80 (3.15)	30 (1.18)	22.3 (0.88)
<b>D15N4</b> <b>D18N4</b>	77 (3.03)	81 (3.19)	30 (1.18)	22.3 (0.88)
<b>D22N4</b>	73 (2.87)	119 (4.69)	30 (1.18)	22.3 (0.88)
<b>D30N4</b> <b>D37N4</b>	69 (2.72)	218 (8.58)	30 (1.18)	22.3 (0.88)
<b>D45N4</b> <b>D55N4</b> <b>D75N4</b>	102 (4)	280 (11)	30 (1.18)	22.3 (0.88)

# Position of the LED indicating DC bus capacitors are charged

## Position of the LED indicating DC bus capacitors are charged

Position of the LED indicating DC bus capacitors are charged for **ATV71W075N4 to D22N4**. See “Drive ratings” on page 9 for the drives in this range.  
Example: **ATV71WD18N4**

Position of the LED indicating DC bus capacitors are charged for **ATV71WD30N4 to D75N4**. See “Drive ratings” on page 9 for the drives in this range.  
Example: **ATV71WD55N4**

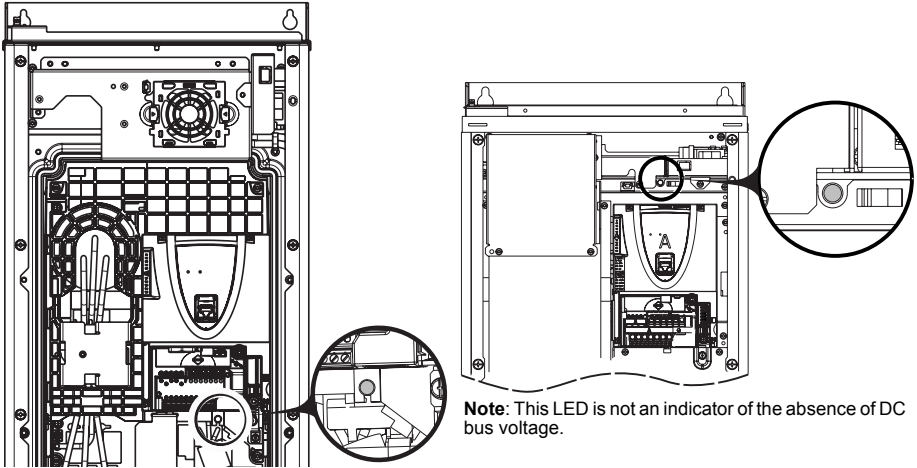

## Procedure for measuring the DC bus voltage

### **▲ DANGER**

#### **HAZARD OF ELECTRIC SHOCK, EXPLOSION, OR ARC FLASH**

Read and understand the instructions on page 5 before performing this procedure.

**Failure to follow these instructions will result in death or serious injury.**

The DC bus voltage can exceed 1000 V  $\overline{\text{---}}$ . Use a properly rated voltage-sensing device when performing this procedure. To measure the DC bus voltage:

- 1 Disconnect the drive power supply.
- 2 Wait 15 minutes to allow the DC bus capacitors to discharge.
- 3 Measure the voltage of the DC bus between the PA/+ and PC/- terminals to ensure that the voltage is less than 42 V  $\overline{\text{---}}$ . See page 15 for the arrangement of the power terminals.
- 4 If the DC bus capacitors do not discharge completely, contact your local Schneider Electric representative. Do not repair or operate the drive.

# Wiring recommendations

## Power

Ground the drive according to local and national code requirements. A minimum wire size of 13.29 mm<sup>2</sup> (6 AWG) may be required to meet standards limiting leakage current.

### ⚠ DANGER

#### HAZARD OF ELECTRIC SHOCK, EXPLOSION, OR ARC FLASH

Ground equipment using the provided ground connecting point as shown in the figure below. The drive panel must be properly grounded before power is applied.

**Failure to follow these instructions will result in death or serious injury.**

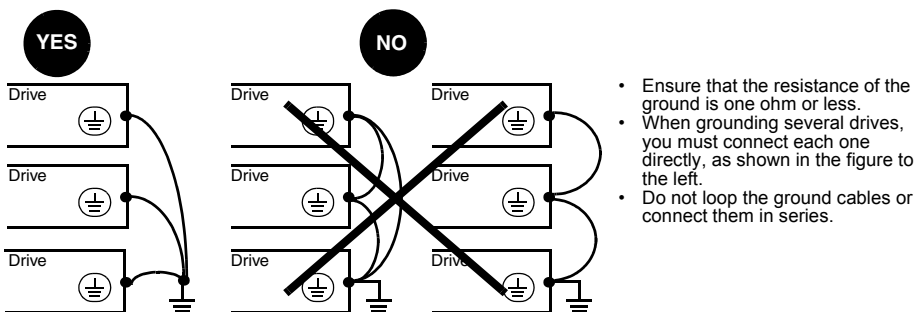

### ⚠ WARNING

#### IMPROPER WIRING PRACTICES

- The ATV71 drive will be damaged if input line voltage is applied to the output terminals (U/T1,V/T2,W/T3).
- Check the power connections before energizing the ATV71 drive.
- If replacing another drive, verify that all wiring connections to the ATV71 drive comply with all wiring instructions in this manual.

**Failure to follow these instructions can result in death, serious injury, or equipment damage.**

Where local and national codes require upstream protection by means of a residual current device, use a type A device for single-phase drives and a type B device for three-phase drives as defined in the IEC Standard 60755. Choose a suitable model integrating:

- High frequency current filtering
- A time delay that helps to prevent tripping caused by the load from stray capacitance on power-up. The time delay is not possible for 30 mA devices; in this case, choose devices with immunity against nuisance tripping.

### ⚠ WARNING

#### INADEQUATE OVERCURRENT PROTECTION

- Overcurrent protective devices must be properly coordinated.
- The Canadian Electrical Code and the National Electrical Code require branch circuit protection. Use the fuses recommended on the drive nameplate to achieve published short-circuit current ratings.
- Do not connect the drive to a power feeder whose short-circuit capacity exceeds the drive short-circuit current rating listed on the drive nameplate.

**Failure to follow these instructions can result in death, serious injury, or equipment damage.**

# Wiring recommendations

## ▲ CAUTION

### IMPROPER USE OF A BRAKING RESISTOR

- Only use the braking resistance values recommended in our catalogs.
- Wire a thermal overload relay in sequence or configure braking resistor protection so that the drive power section AC supply is disconnected in the event of a detected fault. Refer to the Programming Manual.

Failure to follow these instructions can result in injury or equipment damage.

## Terminals

### Access to terminals

The diagrams below illustrate the location of the various terminals on the drive:

Example: ATV71WD18N4

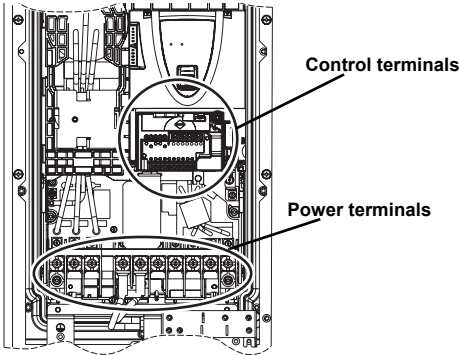

### Functions of power terminals

Terminals	Function
⏚	Ground connection terminal
R/L1 - S/L2 - T/L3	Power section AC line supply
PO	DC bus [+ polarity]
PA/+	Output to braking resistor (+ polarity)
PB	Output to braking resistor
PC/-	DC bus [- polarity]
U/T1 - V/T2 - W/T3	Outputs to the motor



Remove the link between PO and PA/+ only if a DC choke has been added. The PO and PA/+ terminal screws must always be fully tightened, since a high current flows through the common link. See following table for torque values.

# Terminals

## Characteristics of power terminals

ATV71W <sup>1</sup>	Maximum wire size			Tightening torque
	mm <sup>2</sup>	AWG	kcmil	N•m (lb•in)
<b>075N4 ... U40N4</b>	4	10		1.4 (12.3)
<b>U55N4, U75N4</b>	6	8		3 (26.5)
<b>D11N4</b>	16	4		3 (26.5)
<b>D15N4, D18N4</b>	35	2		5.4 (47.7)
<b>D22N4 ... D37N4</b>	50	1/0		12 (102.2)
<b>D45N4 ... D75N4</b>	150		300	41 (360)

1. For drive ranges, refer to page 9 of this guide.



# Terminals

## Terminals for additional internal 24 V supply on the ATV71W●●●●A24

Example: ATV71WD55N4A24

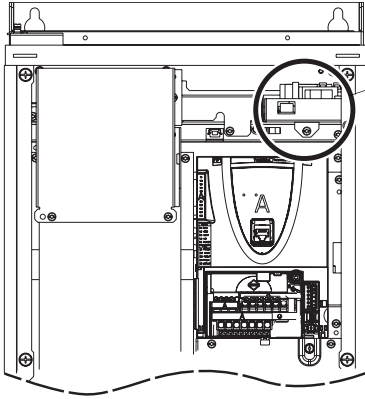

Terminals for internal 24 V supply:

- E0: 0 V
- E24: + 24 V

- Maximum wire size:  
2.5 mm<sup>2</sup> - 14 AWG
- Maximum tightening torque:  
0.6 N•m - 5.3 lb•in

## Removing the control terminal card

To make it easier to wire the drive control section, the control terminal card can be removed:

- 1 Loosen the screw until the spring is fully extended.
- 2 Remove the card by sliding it downwards.

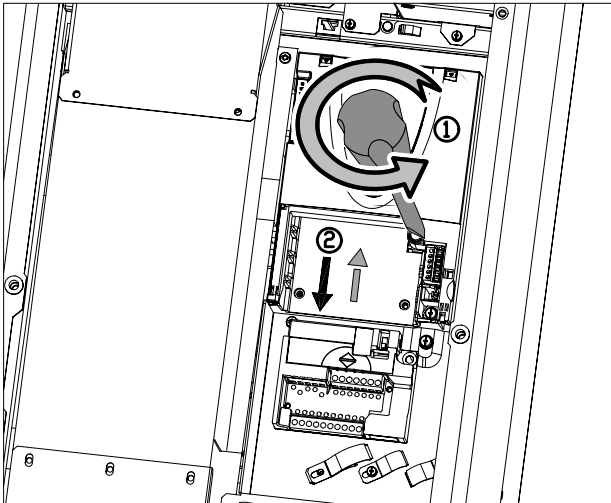

# Terminals

## Arrangement of the control terminals

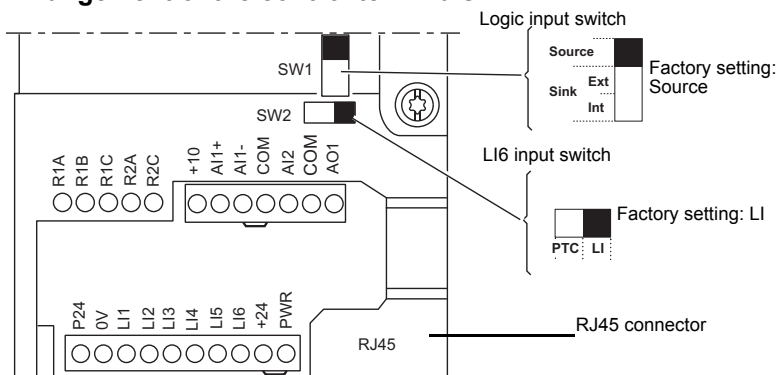

- Maximum wire size: 2.5 mm<sup>2</sup> (14 AWG)
- Maximum tightening torque: 0.6 N•m (5.3 lbf•in)

### ▲ DANGER

#### UNINTENDED EQUIPMENT OPERATION

- The accidental grounding of logic inputs configured for Sink Logic can result in unintended activation of drive functions.
- Protect the signal conductors against damage that could result in unintentional conductor grounding.
- Follow NFPA 79 and EN 60204 guidelines for proper control circuit grounding practices.

**Failure to follow these instructions will result in death or serious injury.**

### CAUTION

#### IMPROPERLY SECURED TERMINAL CARD

When replacing the control terminal card, it is essential to fully tighten the captive screw. Torque the captive screw to 1.1 to 1.7 N•m (9.7 to 15 lbf•in).

**Failure to follow these instructions can result in equipment damage.**

**Note:** The ATV71 drive is supplied with links between the PWR and +24 terminals and the AI1- and COM terminals.

## Characteristics and functions of the control terminals

Terminals	Function	Electrical characteristics
R1A R1B R1C	1 relay logic output, one N.C. contact and one N.O. contact with common point (R1A to R1C is N.O.; R1B to R1C is N.C.)	Minimum switching capacity: 3 mA for 24 V $\text{---}$ Maximum switching capacity: • on resistive load ( $\cos \phi = 1$ ): 5 A for 250 V $\sim$ or 30 V $\text{---}$ • on inductive load ( $\cos \phi = 0.4$ and $L/R = 7$ ms): 2 A for 250 V $\sim$ or 30 V $\text{---}$
R2A R2C	1 relay logic output one N.O. contact	Max. response time: 7 ms $\pm 0.5$ ms Electrical service life: 100,000 operations
+10	+10 V $\text{---}$ power supply for reference potentiometer 1 to 10 k $\Omega$	• +10 V $\text{---}$ (10.5 V $\pm 0.5$ V) • 10 mA max.

NOTE:  $\Delta\theta$  = temperature change

## Characteristics and functions of the control terminals (cont.)

Terminals	Function	Electrical characteristics										
AI1+ AI1-	Differential analog input AI1	<ul style="list-style-type: none"> <li>-10 to +10 V <math>\pm</math> (maximum voltage 24 V)</li> <li>Reaction time: 2 ms <math>\pm</math> 0.5 ms, 11-bit resolution + 1 sign bit</li> <li>Accuracy <math>\pm</math> 0.6% for <math>\Delta\theta = 60^\circ\text{C}</math> (140 <math>^\circ\text{F}</math>), linearity <math>\pm</math> 0.15% of max. value</li> </ul>										
COM	Analog I/O common	0 V										
AI2	Depending on the software configuration: Analog voltage or current input	<ul style="list-style-type: none"> <li>Analog input 0 to +10 V <math>\pm</math> (maximum voltage 24 V), impedance 30 k<math>\Omega</math></li> <li>Analog input X-Y mA, X and Y programmable from 0 to 20 mA, impedance 250 <math>\Omega</math></li> <li>Reaction time: 2 ms <math>\pm</math> 0.5 ms</li> <li>11-bit resolution, accuracy <math>\pm</math> 0.6% for <math>\Delta\theta = 60^\circ\text{C}</math> (140 <math>^\circ\text{F}</math>), linearity <math>\pm</math> 0.15% of max. value</li> </ul>										
COM	Analog I/O common	0 V										
AO1	Depending on the software configuration: Analog voltage or current output or logic output	<ul style="list-style-type: none"> <li>Analog output 0 to +10 V <math>\pm</math>, min. load impedance 50 k<math>\Omega</math></li> <li>Analog output X-Y mA, X and Y can be programmed from 0 to 20 mA, max. load impedance 500 <math>\Omega</math></li> <li>10-bit resolution, reaction time: 2 ms <math>\pm</math> 0.5 ms</li> <li>Accuracy <math>\pm</math> 1% for <math>\Delta\theta = 60^\circ\text{C}</math> (140 <math>^\circ\text{F}</math>), linearity <math>\pm</math> 0.2% of max. value</li> <li>Logic output: 0 or 10 V, 0 to 20 mA</li> </ul>										
P24	Input for external +24 V $\pm$ control power supply	<ul style="list-style-type: none"> <li>+24 V <math>\pm</math> (min. 19 V, max. 30 V)</li> <li>Power 30 W</li> </ul>										
0V	Logic input common and 0 V of external P24 power supply	0 V										
LI1 LI2 LI3 LI4 LI5	Programmable logic inputs	<table border="1"> <tr> <td rowspan="3"> <ul style="list-style-type: none"> <li>+24 V <math>\pm</math> (max. 30 V)</li> <li>Impedance 3.5 k<math>\Omega</math></li> <li>Reaction time: 2 ms <math>\pm</math> 0.5 ms</li> </ul> </td> <td><b>SW1 Switch</b></td> <td><b>State 0</b></td> <td><b>State 1</b></td> </tr> <tr> <td>Source (factory setting)</td> <td>&lt; 5 V <math>\pm</math></td> <td>&gt; 11 V <math>\pm</math></td> </tr> <tr> <td>Sink Int or Sink Ext</td> <td>&gt; 16 V <math>\pm</math></td> <td>&lt; 10 V <math>\pm</math></td> </tr> </table>	<ul style="list-style-type: none"> <li>+24 V <math>\pm</math> (max. 30 V)</li> <li>Impedance 3.5 k<math>\Omega</math></li> <li>Reaction time: 2 ms <math>\pm</math> 0.5 ms</li> </ul>	<b>SW1 Switch</b>	<b>State 0</b>	<b>State 1</b>	Source (factory setting)	< 5 V $\pm$	> 11 V $\pm$	Sink Int or Sink Ext	> 16 V $\pm$	< 10 V $\pm$
<ul style="list-style-type: none"> <li>+24 V <math>\pm</math> (max. 30 V)</li> <li>Impedance 3.5 k<math>\Omega</math></li> <li>Reaction time: 2 ms <math>\pm</math> 0.5 ms</li> </ul>	<b>SW1 Switch</b>	<b>State 0</b>		<b>State 1</b>								
	Source (factory setting)	< 5 V $\pm$		> 11 V $\pm$								
	Sink Int or Sink Ext	> 16 V $\pm$	< 10 V $\pm$									
LI6	Depending on the position of the SW2 switch: LI (Programmable logic input) or PTC (Input for PTC probes)	SW2 = LI (factory setting): <ul style="list-style-type: none"> <li>Same characteristics as logic inputs LI1 to LI5</li> </ul> SW2 = PTC: <ul style="list-style-type: none"> <li>Trip threshold 3 k<math>\Omega</math>, reset threshold 1.8 k<math>\Omega</math></li> <li>Short-circuit detection threshold &lt; 50 <math>\Omega</math></li> </ul>										
+24	Logic input power supply	SW1 switch in Source or Sink Int position: <ul style="list-style-type: none"> <li>Internal +24 V <math>\pm</math> power supply (min. 21 V, max. 27 V), protected against short-circuits and overloads</li> <li>200 mA max.</li> </ul> SW1 switch in Sink Ext position: <ul style="list-style-type: none"> <li>Input for external +24 V <math>\pm</math> power supply for the logic inputs</li> </ul>										
PWR	Power Removal function input	<ul style="list-style-type: none"> <li>24 V <math>\pm</math> (max. 30 V)</li> <li>Impedance 1.5 k<math>\Omega</math></li> <li>State 0 if &lt; 2 V, state 1 if &gt; 17 V</li> <li>Reaction time: 10 ms</li> </ul>										
	When PWR is not connected to 24 V, the motor cannot be started (compliance with functional safety standard EN 954-1 category 3, "Safety of machinery, Safety related parts of control systems," and IEC 61508 "Functional safety of electrical/electronic/programmable electronic safety-related systems.")											

NOTE:  $\Delta\theta$  = temperature change

# Terminals

## Characteristics and functions of the terminals: VW3A3201 option card

Maximum wire size: 1.5 mm<sup>2</sup> (16 AWG)

Maximum tightening torque: 0.25 N·m (2.21 lbf·in)

R3A, R3B, R3C, and LI7–LI10 have the same characteristics as the control card.

Terminals	Function	Electrical characteristics
TH1+ TH1-	PTC probe input	<ul style="list-style-type: none"> <li>• Trip threshold 3 kΩ, reset threshold 1.8 kΩ</li> <li>• Short-circuit detection threshold &lt; 50 Ω</li> </ul>
LO1 LO2	Open collector programmable logic outputs	<ul style="list-style-type: none"> <li>• +24 V <math>\overline{\text{---}}</math> (max. 30 V)</li> <li>• Max. current 200 mA for internal power supply and 200 mA for external power supply</li> <li>• Reaction time: 2 ms <math>\pm</math>0.5 ms</li> </ul>
CLO	Logic output common	—
0 V	0 V	0 V

## Characteristics and functions of the terminals: VW3A3202 option card

Maximum wire size: 1.5 mm<sup>2</sup> (16 AWG). Maximum tightening torque: 0.25 N·m (2.21 lbf·in)

R4A, R4B, R4C, and LI11–LI14 have the same characteristics as the control card.

Terminals	Function	Electrical characteristics
TH2 + TH2 -	PTC probe input	<ul style="list-style-type: none"> <li>• Trip threshold 3 kΩ, reset threshold 1.8 kΩ</li> <li>• Short-circuit detection threshold &lt; 50 Ω</li> </ul>
RP	Frequency input	<ul style="list-style-type: none"> <li>• Frequency range 0 ... 30 kHz</li> <li>• Maximum input voltage 30 V, 15 mA</li> <li>• Add a resistor if the input voltage is greater than 5 V (510 Ω for 12 V, 910 Ω for 15 V, 1.3 kΩ for 24 V)</li> <li>• State 0 if &lt; 1.2 V, state 1 if &gt; 3.5 V</li> </ul>
LO3 LO4	Open collector programmable logic outputs	<ul style="list-style-type: none"> <li>• + 24 V <math>\overline{\text{---}}</math> (max. 30 V)</li> <li>• Max. current 20 mA for internal power supply and 200 mA for external power supply</li> <li>• Reaction time: 5 ms <math>\pm</math>0.5 ms</li> </ul>
CLO	Logic output common	—
0 V	0 V	0 V

## Characteristics and functions of the terminals: Encoder interface card

Maximum wire size: 1.5 mm<sup>2</sup> (16 AWG)

Maximum tightening torque: 0.25 N·m (2.21 lbf·in)

Terminals	Function	Electrical characteristics	
		VW3A3401	VW3A3402, VW3A3404, VW3A3406
+Vs 0Vs	Encoder power supply	<ul style="list-style-type: none"> <li>• 5 V <math>\overline{\text{---}}</math> (max. 5.5 V <math>\overline{\text{---}}</math>) protected against short-circuits and overloads</li> <li>• Max. current 200 mA</li> </ul>	<ul style="list-style-type: none"> <li>• 15 V <math>\overline{\text{---}}</math> (max. 16 V <math>\overline{\text{---}}</math>) protected against short-circuits and overloads</li> <li>• Max. current 175 mA</li> </ul>
A, /A B, /B	Incremental logic inputs	<ul style="list-style-type: none"> <li>• Max. resolution: 5000 points/rev</li> <li>• Max. frequency: 300 kHz</li> </ul>	

Terminals	Function	Electrical characteristics	
		VW3A3403, VW3A3405	VW3A3407
+Vs 0Vs	Encoder power supply	<ul style="list-style-type: none"> <li>• 12 V <math>\overline{\text{---}}</math> (max. 13 V <math>\overline{\text{---}}</math>) protected against short-circuits and overloads</li> <li>• Max. current 175 mA</li> </ul>	<ul style="list-style-type: none"> <li>• 24 V <math>\overline{\text{---}}</math> (min. 20 V <math>\overline{\text{---}}</math>, max. 30 V <math>\overline{\text{---}}</math>) protected against short-circuits and overloads</li> <li>• Max. current 100 mA</li> </ul>
A, /A B, /B	Incremental logic inputs	<ul style="list-style-type: none"> <li>• Max. resolution: 5000 points/rev</li> <li>• Max. frequency: 300 kHz</li> </ul>	

### Type of incremental encoder outputs to be used

- RS422 outputs: **VW3A3401** or **VW3A3402**
- Open collector outputs: **VW3A3403** or **VW3A3404**
- "Push-pull" outputs: **VW3A3405**, **VW3A3406**, or **VW3A3407**

# Connection diagrams

Diagrams conforming to standards EN 954-1 category 1, IEC 61508 capacity SIL1, stopping category 0 in accordance with IEC/EN 60204-1<sup>1</sup>

Three phase power supply with upstream isolation via contactor

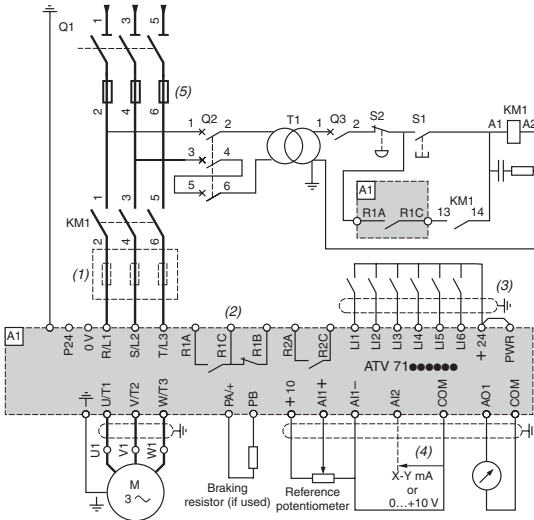

**Note:** Install interference suppressors on all inductive circuits (such as relays, contactors, solenoid valves, and florescent lighting) near the drive or connected on the same circuit.

**Choice of associated components:** Please refer to the catalog.

- (1) Line reactor, if used
- (2) Relay contacts for remote signalling of the drive status
- (3) Connection of the logic input common depends on the position of the SW1 switch
- (4) Software-configurable current (0...20 mA) or voltage (0...10 V) analog input
- (5) Fuses

**Note:** See page 28 for factory programming configuration.

## ▲ CAUTION

### IMPROPER USE OF A BRAKING RESISTOR

- Only use the braking resistance values recommended in our catalogs.
- Wire a thermal overload relay in sequence or configure braking resistor protection so that the drive power section AC supply is disconnected in the event of a detected fault. Refer to the Programming Manual.

**Failure to follow these instructions can result in injury or equipment damage.**

1. EN 954-1: "Safety of machinery, Safety related parts of control systems."  
 IEC 61508: "Functional safety of electrical/electronic/programmable electronic safety-related systems"  
 IEC/EN 60204-1: "Safety of Machinery—Electrical Equipment of Machines—Part 1: General Requirements for Electrical Equipment on Machines"

# Connection diagrams

## Control card connection diagram

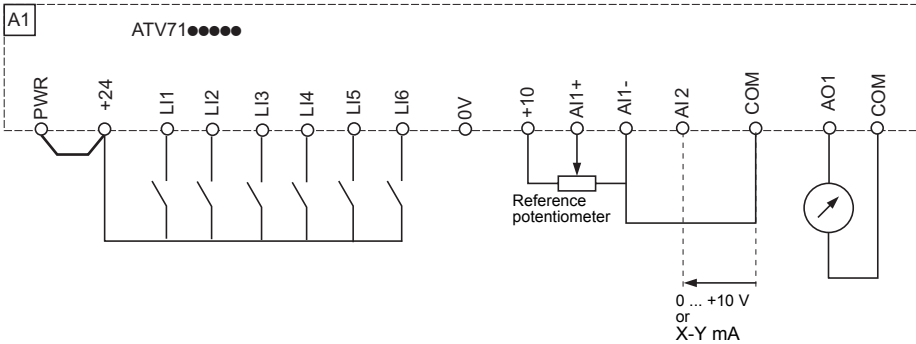

## Logic input switch (SW1)

The logic input switch (SW1) is used to adapt the operation of the logic inputs to the technology of the programmable controller outputs.

- Set the switch to Source (factory setting) if using PLC outputs with PNP transistors.
- Set the switch to Sink Int or Sink Ext if using PLC outputs with NPN transistors.

### Internal power supply

SW1 switch set to "Source" position

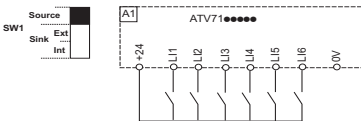

SW1 switch set to "Sink Int" position

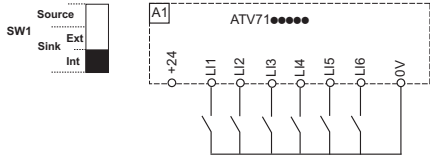

### External power supply

SW1 switch set to "Source" position

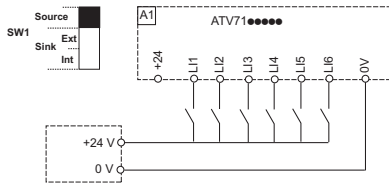

SW1 switch set to "Sink Ext" position

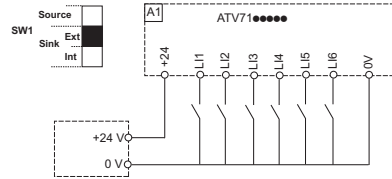

## ▲ DANGER

### UNINTENDED EQUIPMENT OPERATION

- The accidental grounding of logic inputs configured for Sink Logic can result in unintended activation of drive functions.
- Protect the signal conductors against damage that could result in unintentional conductor grounding.
- Follow NFPA 79 and EN 60204 guidelines for proper control circuit grounding practices.

**Failure to follow these instructions will result in death or serious injury.**

# Connection diagrams

## Bipolar speed reference

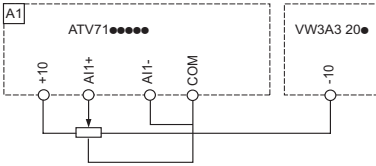

## SW2 switch

The LI6 logic input switch (SW2) makes it possible to use the LI6 input:

- Either as a logic input by setting the switch to LI (factory setting)
- Or for motor protection via PTC probes by setting the switch to PTC

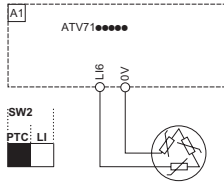

## Control power supply via an external source

The control card can be powered by an external +24 V  $\text{---}$  supply

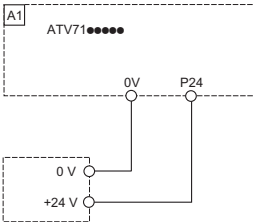

## Connection diagrams for option cards

Please refer to the Installation Manual on the CD-ROM supplied with the drive.

## Additional internal 24 V supply on ATV71W●●●●●A24

The 24 V supply is provided by the drive's DC bus.

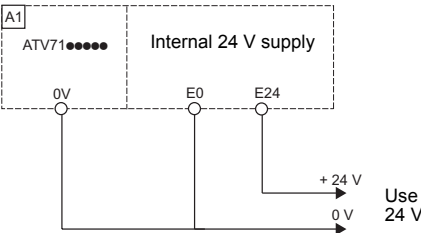

# Operation on an IT or corner grounded delta system

## ATV71W●●●N4 with integrated class A EMC filter

When operating the drive on an IT system (isolated or impedance grounded neutral), use a permanent insulation monitor compatible with non-linear loads, such as a Merlin Gerin type XM200 or equivalent.

Altivar 71W drives feature built-in RFI filters. When an ATV71W●●●N4 is operating on an isolated or impedance grounded electrical distribution system or a corner grounded delta system, these filters must be isolated (disconnected) from ground as follows.

A jumper must be set to disconnect the filters on ATV71●●●N4 drives, with the exception of ATV71●D30N4 drives, which have two jumpers head-to-tail.

These jumpers are located on the bottom left near terminal L1.

**Example: ATV71WD18N4**

**Example: ATV71WD30N4**

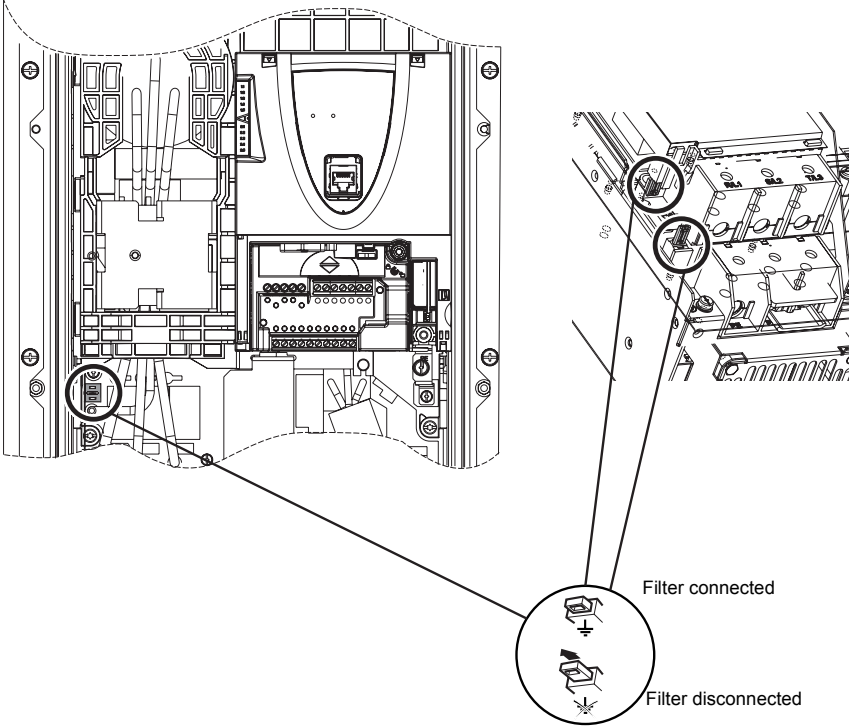

On ATV71W●●●A24 drives, do not move the 24 V power supply jumper, which is factory-set to disconnected.

### CAUTION

#### DAMAGE TO DRIVE

- Do not exceed 4 kHz switching frequency if the filters are disconnected.
- Refer to the Programming Manual on the CD-ROM supplied with the drive to adjust parameter SFr.

**Failure to follow these instructions can result in equipment damage.**



# Electromagnetic compatibility, wiring

## Principle and precautions

**IMPORTANT:** The high frequency equipotential ground connection between the drive, motor, and cable shielding does not eliminate the need to connect the ground (PE) conductors (green-yellow) to the appropriate terminals on each unit. To help accomplish this, the user must follow the following points:

- Grounds between the drive, motor, and cable shielding must have high-frequency equipotentiality.
- When using shielded cable for the motor, use a 4-conductor cable so that one wire will be the ground connection between the motor and the drive. Size of the ground conductor must be selected in compliance with local and national codes. The shield can then be grounded at both ends. Metal ducting or conduit can be used for part or all of the shielding length, provided there is no break in continuity.
- When using shielded cable for the Dynamic Brake (DB) resistors, use a 3-conductor cable so that one wire will be the ground connection between the DB resistor assembly and the drive. Size of the ground conductor must be selected in compliance with local and national codes. The shield can then be grounded at both ends. Metal ducting or conduit can be used for part or all of the shielding length, provided there is no break in continuity.
- When using shielded cable for control signals, if the cable is connecting equipment that is close together and the grounds are bonded together, then both ends of the shield can be grounded. If the cable is connected to equipment that may have a different ground potential, then ground the shield at one end only to prevent large currents from flowing in the shield. The shield on the ungrounded end may be tied to ground with a capacitor (for example: 10 nF, 100 V or higher) in order to provide a path for the higher frequency noise.
- Keep the control circuits away from the power circuits. For control and speed reference circuits, use of shielded twisted cables with a pitch of between 25 and 50 mm (0.98 and 1.97 in.) is recommended.
- Ensure maximum separation between the power supply cable (line supply) and the motor cable and also ensure maximum separation between the control cables and any power cables.
- The motor cables must be at least 0.5 m (20 in.) long.
- Do not use surge arresters or power factor correction capacitors on the variable speed drive output.
- If using an additional input filter, refer to the Installation Guide for more information.
- For installation of the EMC plate provided with the drive and instructions for meeting EN55011 Class A directive, refer to the Installation Guide.

## Connection plates:

There is a metric connection plate on the lower section of the drives.

**Note:** In the U.S., the ATV71W●●●N4 drives come with a metric plate mounted to the drive and an additional blank connection plate requiring holes punched to the appropriate conduit size.

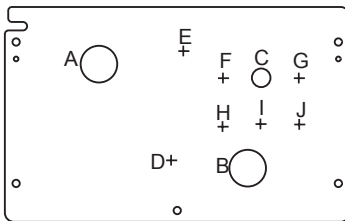

- A:** Hole for line supply cable
- B:** Hole for shielded motor cable (use a metal cable gland)
- C:** Hole for control cable

The plates also feature markings should holes be required for:

- D:** DC bus or braking resistor cable
- E:** Communication option cable
- F, G, H, I, J:** Control cables

## Diameters of holes for ATV71W●●●●N4

ATV71W <sup>1</sup>	IP54 drive plates		
	A mm (in)	B mm (in)	C mm (in)
<b>075N4 to U55N4</b>	20.5 (0.81)	25.5 (1.00)	16.4 (0.65)
<b>U75N4 to D11N4</b>	20.5 (0.81)	25.5 (1.00)	16.4 (0.65)
<b>D15N4 to D22N4</b>	32.5 (1.28)	32.5 (1.28)	16.4 (0.65)
<b>D30N4</b>	40.5 (1.60)	40.5 (1.60)	16.4 (0.65)
<b>D37N4 to D45N4</b>	50.5 (1.99)	40.5 (1.60)	16.4 (0.65)
<b>D55N4 to D75N4</b>	63.5 (2.50)	50.5 (1.99)	16.4 (0.65)
<b>D90N4</b>	63.5 (2.50)	50.5 (1.99)	16.4 (0.65)

1. For drive ranges, refer to page 9 of this guide.

# Electromagnetic compatibility, wiring

## Installation diagram, control cables

ATV71● 075N4 to D22N4. See “Drive ratings” on page 9 for the drives in this range.

Mount and ground the shielding of cables 2, 3, and 5 as close as possible to the drive:

- Strip the cable to expose the shielding.
- Use stainless metal cable clamps on the parts from which the shielding has been stripped, to attach them to the plate (1).
- The exposed shielding must be clamped tightly enough to the metal sheet to ensure proper electrical contact.

Example:

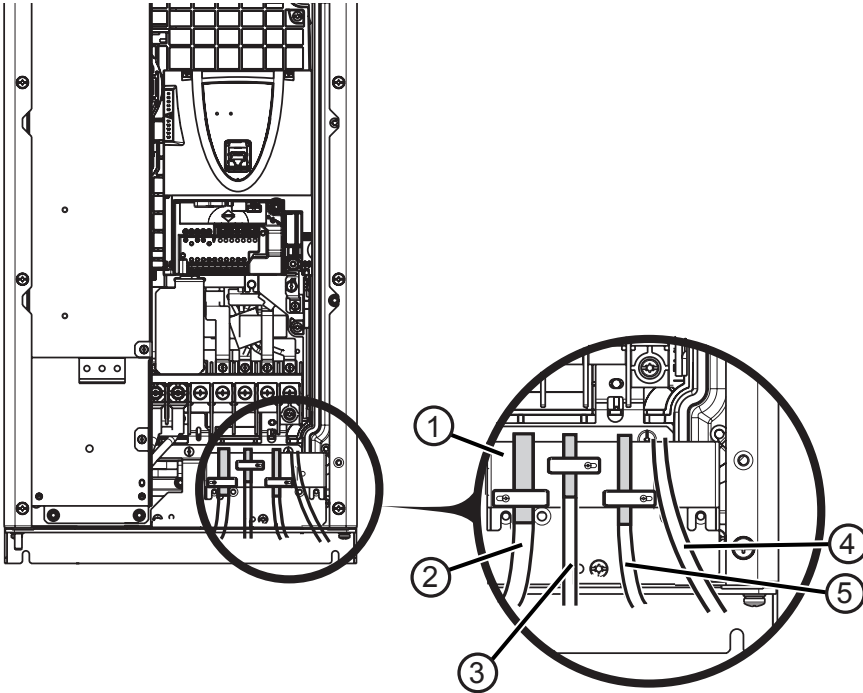

1 Grounded casing

2 Shielded cables for connecting the control-signal section. For applications requiring several conductors, use cables with a small cross-section ( $0.5 \text{ mm}^2$  - 20 AWG).

3 Shielded cables for connecting the encoder

4 Non-shielded wires for relay contact output

5 Shielded cables for connecting the Power Removal function input

# Electromagnetic compatibility, wiring

## Installation diagram, control cables

ATV71● D30N4 to D75N4. See “Drive ratings” on page 9 for the drives in this range.

Mount and ground the shielding of cables 1, 2, and 3 as close as possible to the drive:

- Strip the cable to expose the shielding.
- Use stainless metal cable clamps to attach the parts from which the shielding has been stripped.
- The exposed shielding must be clamped tightly enough to the metal sheet to ensure proper electrical contact.

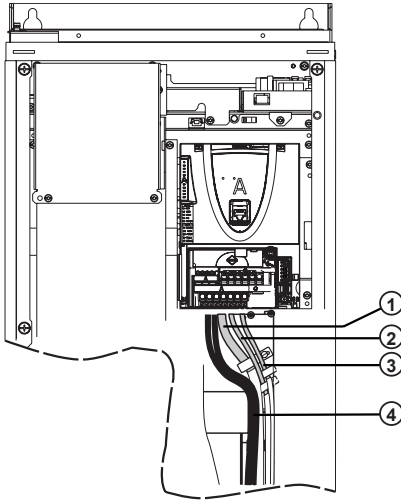

- 1 Shielded cables for connecting the control-signal section. For applications requiring several conductors, use cables with a small cross-section ( $0.5 \text{ mm}^2$  - 20 AWG).
- 2 Shielded cables for connecting the Power Removal function input
- 3 Shielded cables for connecting the encoder
- 4 Unshielded wires for the relay contact output

## Mounting and connecting the shielded motor cable with metal cable gland (not supplied with the drive)

- Prepare the shielded cable by stripping both ends ready for connection.
- Loosen the cover of the cable gland.
- Attach the shielded cable to the cable gland ensuring it is fully in contact (throughout  $360^\circ$ ).
- Fold back the exposed shielding and clamp it between the ring and the body of the cable gland, and tighten the cover.

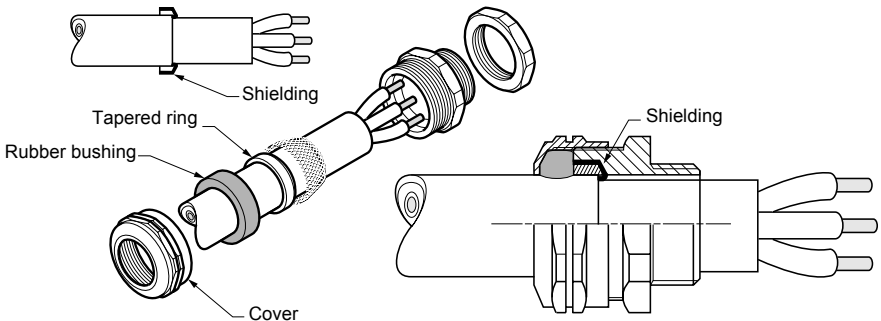

# Setup - preliminary recommendations

## Drive settings (factory configuration)

The Altivar 71 is factory-set for the most common operating conditions:

- Macro configuration: Start/Stop
- **Motor** frequency: 50 Hz
- Constant torque applications, with sensorless flux vector control
- Normal stop mode on deceleration ramp
- Stop mode in the event of a detected fault: Freewheel
- Linear, acceleration and deceleration ramps: 3 seconds
- Low speed: 0 Hz
- High speed: 50 Hz
- Motor thermal current = rated drive current
- Standstill injection braking current = 0.7 x rated drive current, for 0.5 seconds
- No automatic starts after a detected fault
- Switching frequency 2.5 kHz or 12 kHz depending on drive rating
- Logic inputs:
  - LI1: Forward (1 operating direction), 2-wire control on transition
  - LI2: Inactive (not assigned)
  - LI3: Switching of 2<sup>nd</sup> speed reference, Ref 1B Switching
  - LI4: Drive reset after a detected fault is cleared
  - LI5, LI6: Inactive (not assigned)
- Analog inputs:
  - AI1: 1<sup>st</sup> speed reference 0 +10 V, Ref 1 Channel
  - AI2: 2<sup>nd</sup> speed reference 0-20 mA, Ref 1B Channel
- Relay R1: The R1C to R1A contact opens and the R1C to R1B contact closes in the event of a detected fault or when the drive is powered off.
- Relay R2: The R2A to R2C contact closes when the drive is running.
- Analog output AO1: 0-20 mA, Motor Frequency

For programming instructions, consult the Altivar 71 Programming Manual provided on the CD-ROM included with the drive.

## Option card factory settings

The option card inputs/outputs are not factory-set.

## Power switching via line contactor

### CAUTION

#### EXCESSIVE LINE CONTACTOR SWITCHING

- Avoid operating the contactor frequently to avoid premature aging of the filter capacitors.
- Do not have cycle times less than 60 seconds.

**Failure to follow these instructions can result in equipment damage.**

## Starting

### Important:

In factory settings mode, the motor can only be supplied with power once the “forward,” “reverse,” and “DC injection stop” commands have been reset in the following instances: on power-up, on a manual drive reset after a fault is cleared, or after a stop command.

If the commands have not been reset, the drive will display “nSt” and will not start.

## Test on low-power motor or without motor, use of motors in parallel

Consult the Programming Manual on the CD-ROM supplied with the drive.

# Graphic display terminal

## Description of terminal

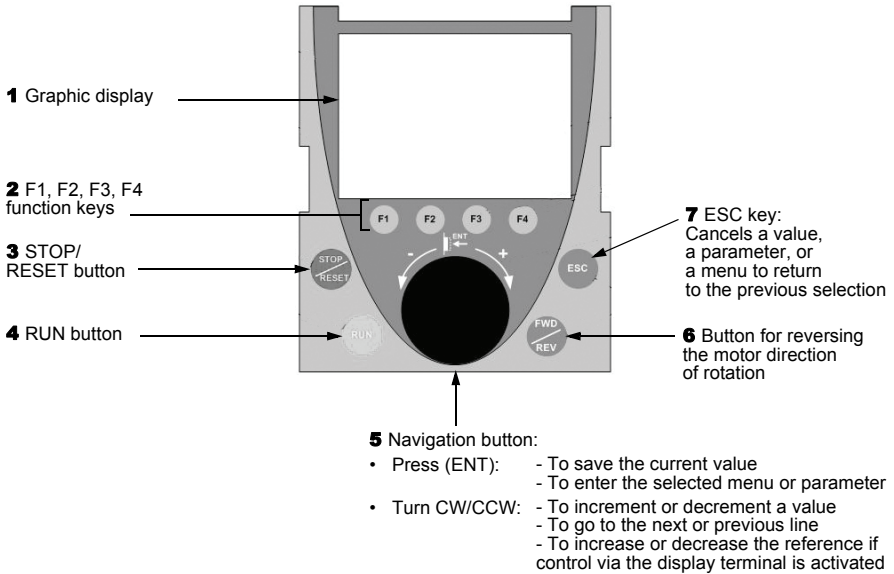

**Note:** Buttons 3, 4, 5, and 6 can be used to control the drive directly, if control via the terminal is activated.

## Drive state codes

- ACC: Acceleration
- CLI: Current limiting
- CTL: Controlled stop on input phase loss
- DCB: DC injection braking in progress
- DEC: Deceleration
- FLU: Motor fluxing in progress
- FRF: Drive at fallback speed
- FST: Fast stop
- NLP: No line power (no line supply on L1, L2, L3)
- NST: Freewheel stop
- OBR: Auto-adapted deceleration
- PRA: Power Removal function active (drive locked)
- RDY: Drive ready
- RUN: Drive running
- SOC: Controlled output cut in progress
- TUN: Auto-tuning in progress
- USA: Undervoltage alarm

The first time the drive is powered on, the user is automatically guided through the menus as far as [1. DRIVE MENU].

The parameters in the [1.1 SIMPLY START] submenu must be configured and auto-tuning performed before the motor is started.

# Graphic display terminal



Only the [1.1 SIMPLY START] menu is described in this document. For more information about the content of the other menus, consult the Programming Manual on the CD-ROM supplied with the drive.

<b>ATV71W075N4</b> 0.75 kW/1 HP 380/480 V Config. no.1
--

Displayed for 3 seconds following power-up

3 seconds ↓

5 LANGUAGE
English ✓

Switches to [5 LANGUAGE] menu automatically.

Select the language and press ENT.



Term +0.00Hz REM
2 ACCESS LEVEL
Basic ✓

Switches to [2 ACCESS LEVEL] menu (consult the Programming Manual on the CD-ROM supplied with the drive)

Select the access level and press ENT.



Term +0.00Hz REM
1 DRIVE MENU
1.1 SIMPLY START
Code << >> T/K

Switches to [1 DRIVE MENU]

(consult the Programming Manual on the CD-ROM supplied with the drive)

ESC ↓

Term +0.00Hz REM
MAIN MENU
1 DRIVE MENU
Code T/K

Press ESC to return to [MAIN MENU]

# [1.1 SIMPLY START] (SIM-) menu

## ▲ DANGER

### UNINTENDED EQUIPMENT OPERATION

- Changes to parameters in other menus may change the [1.1 SIMPLY START] (SIM-) parameter settings.
- Read and understand the ATV71 Programming Manual before configuring parameter values.

**Failure to follow these instructions will result in death or serious injury.**

The [1.1 SIMPLY START] (SIM-) menu can be used to quickly configure key parameters to get the drive and motor running. Modifying parameters in other menus may modify the parameter settings in the [1.1 SIMPLY START] (SIM-) menu. As an example, configuration of motor parameters in [1.4 MOTOR CONTROL] (drC-) will be reflected in the [1.1 SIMPLY START] (SIM-) parameters. The [1.1-SIMPLY START] (SIM-) menu can be used for quick startup, which is sufficient for many applications.



**Note:** The parameters of the [1.1 SIMPLY START] (SIM-) menu must be entered in the order in which they appear, as the later ones are dependent on the first ones.

For example [2/3 wire control] (tCC) must be configured before any other parameters.

## Macro configuration

Selecting a macro configuration allows you to quickly configure the drive with settings that are suitable for a specific application. Selecting a macro configuration assigns the Inputs/Outputs in this macro configuration.

Input/output	[Start/Stop]	[M. handling]	[Gen. Use]	[Hoisting]	[PID regul.]	[Network C.]	[Mast./slave]
AI1	[Ref.1 channel]	[Ref.1 channel]	[Ref.1 channel]	[Ref.1 channel]	[Ref.1 channel] (PID reference)	[Ref.2 channel] ([Ref.1 channel] via the bus)	[Ref.1 channel]
AI2	[No]	[Summing ref. 2]	[Summing ref. 2]	[No]	[PID feedback]	[No]	[Torque reference]
AO1	[Motor freq.]	[Motor freq.]	[Motor freq.]	[Motor freq.]	[Motor freq.]	[Motor freq.]	[Sign. torque]
R1	[No drive ft]	[No drive ft]	[No drive ft]	[No drive ft]	[No drive ft]	[No drive ft]	[No drive ft]
R2	[No]	[No]	[No]	[Brk control]	[No]	[No]	[No]
LI1 (2-wire)	[Forward]	[Forward]	[Forward]	[Forward]	[Forward]	[Forward]	[Forward]
LI2 (2-wire)	[Reverse]	[Reverse]	[Reverse]	[Reverse]	[Reverse]	[Reverse]	[Reverse]
LI3 (2-wire)	[No]	[2 preset speeds]	[Jog]	[Fault reset]	[PID integral reset]	[Ref. 2 switching]	[Trq/spd switching]
LI4 (2-wire)	[No]	[4 preset speeds]	[Fault reset]	[External fault]	[2 preset PID ref.]	[Fault reset]	[Fault reset]
LI5 (2-wire)	[No]	[8 preset speeds]	[Torque limitation]	[No]	[4 preset PID ref.]	[No]	[No]
LI6 (2-wire)	[No]	[Fault reset]	[No]	[No]	[No]	[No]	[No]
LI1 (3-wire)	Stop	Stop	Stop	Stop	Stop	Stop	Stop
LI2 (3-wire)	[Forward]	[Forward]	[Forward]	[Forward]	[Forward]	[Forward]	[Forward]
LI3 (3-wire)	[Reverse]	[Reverse]	[Reverse]	[Reverse]	[Reverse]	[Reverse]	[Reverse]
LI4 (3-wire)	[No]	[2 preset speeds]	[Jog]	[Fault reset]	[PID integral reset]	[Ref. 2 switching]	[Trq/spd switching]
LI5 (3-wire)	[No]	[4 preset speeds]	[Fault reset]	[External fault]	[2 preset PID ref.]	[Fault reset]	[Fault reset]
LI6 (3-wire)	[No]	[8 preset speeds]	[Torque limitation]	[No]	[4 preset PID ref.]	[No]	[No]

In 3-wire control, the assignment of inputs LI1 to LI6 shifts.

Factory settings.

**Note:** The settings can be modified, adjusted and reassigned. Consult the ATV71 Programming Manual on the CD-ROM supplied with the drive.

# [1.1 SIMPLY START] (SIM-) menu

The following table describes the codes, adjustment range, and factory settings.

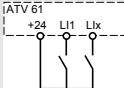
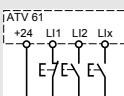
Code	Name/Description	Adjustment range	Factory setting
<p>ㄥㄥㄥ</p> <p>ㄨㄥ</p> <p>ㄨㄥ</p>	<p><input type="checkbox"/> [2/3 wire control]</p> <p><input type="checkbox"/> [2 wire] (2C)</p> <p><input type="checkbox"/> [3 wire] (3C)</p> <p><b>2-wire control:</b> This is the input state (0 or 1) or edge (0 to 1 or 1 to 0), which controls running or stopping.</p> <p><b>3-wire control</b> (Pulse control): A “forward” or “reverse” pulse is sufficient to command starting, a “stop” pulse is sufficient to command stopping.</p> <div style="display: flex; justify-content: space-around;"> <div style="text-align: center;">  </div> <div style="text-align: left;"> <p>Example of “source” wiring: L1: Forward Lx: Reverse</p> </div> </div> <div style="display: flex; justify-content: space-around; margin-top: 10px;"> <div style="text-align: center;">  </div> <div style="text-align: left;"> <p>Example of “source” wiring: L1: Stop L2: Forward Lx: Reverse</p> </div> </div>		[2 wire] (2C)
<p><b>⚠ DANGER</b></p>			
<p><b>UNINTENDED EQUIPMENT OPERATION</b></p> <ul style="list-style-type: none"> <li>To change the assignment of [2/3 wire control] (tCC), press and hold down the ENT key for 2 seconds.</li> <li>The [2 wire type] (tCT) function and the functions assigning the logic inputs and analog inputs will return to their factory settings. The selected macro configuration will reset, losing its custom settings.</li> <li>Ensure that this parameter is configured before configuring [1.6 COMMAND] (CtI) and [1.7 APPLICATION FUNCT.] (FUN-).</li> <li>Ensure that this assignment change is compatible with the wiring scheme used.</li> <li>For more information, consult the Programming Manual on the CD-ROM provided with the drive.</li> </ul> <p><b>Failure to follow these instructions will result in death or serious injury.</b></p>			
<p>ㄥㄈㄈ</p> <p>ㄨㄥㄨ</p> <p>ㄨㄨㄥ</p> <p>ㄈㄥㄥ</p> <p>ㄈㄥㄥ</p> <p>ㄈㄥㄥ</p> <p>ㄈㄥㄥ</p> <p>ㄈㄥㄥ</p> <p>ㄈㄥㄥ</p>	<p><input type="checkbox"/> [Macro configuration]</p> <p><input type="checkbox"/> [Start/Stop] (StS): Start/stop</p> <p><input type="checkbox"/> [M. handling] (HdG): Material handling</p> <p><input type="checkbox"/> [Hoisting] (HSt): Hoisting</p> <p><input type="checkbox"/> [Gen. Use] (GEn): General use</p> <p><input type="checkbox"/> [PID regul.] (PId): PID regulation</p> <p><input type="checkbox"/> [Network C.] (nEt): Communication bus</p> <p><input type="checkbox"/> [Mast./slave] (MSL): Master/slave</p>		[Pumps.Fans] (PnF)
<p><b>⚠ DANGER</b></p>			
<p><b>UNINTENDED EQUIPMENT OPERATION</b></p> <ul style="list-style-type: none"> <li>To change the assignment of [Macro configuration] (CFG), press and hold down the ENT key for 2 seconds.</li> <li>Ensure that the selected macro configuration is compatible with the wiring scheme used.</li> </ul> <p><b>Failure to follow these instructions will result in death or serious injury.</b></p>			
<p>ㄥㄥㄈㄈ</p> <p>ㄨㄥㄨㄨ</p>	<p><input type="checkbox"/> [Customized macro]</p> <p>Read-only parameter, only visible if at least one macro configuration parameter has been modified.</p> <p><input type="checkbox"/> [Yes] (YES)</p>		



# [1.1 SIMPLY START] (SIM-) menu

Code	Name/Description	Adjustment range	Factory setting
<i>bFr</i> <i>50</i> <i>60</i>	<input type="checkbox"/> <b>[Standard mot. freq]</b>  <input type="checkbox"/> <b>[50 Hz IEC] (50): IEC</b> <input type="checkbox"/> <b>[60 Hz NEMA] (60): NEMA</b> This parameter modifies the presets of the following parameters: [Rated motor power] (nPr), [Rated motor volt.] (UnS), [Rated mot. current] (nCr), [Rated motor freq.] (FrS), [Rated motor speed] (nSP) and [Max frequency] (tFr) below, [Mot. therm. current] (ItH) page 35, [High speed] (HSP) page 35.		[50 Hz IEC] (50)
<i>nPr</i>	<input type="checkbox"/> <b>[Rated motor power]</b>  Rated motor power given on the nameplate, in kW if [Standard mot. freq] (bFr) = [50 Hz IEC] (50), in HP if [Standard mot. freq] (bFr) = [60 Hz NEMA] (60).	According to drive rating	According to drive rating
<i>UnS</i>	<input type="checkbox"/> <b>[Rated motor volt.]</b>  Rated motor voltage given on the nameplate.	200 to 480 V	400 or 460 V according to [Standard mot. freq] (bFr)
<i>nCr</i>	<input type="checkbox"/> <b>[Rated mot. current]</b>  Rated motor current given on the nameplate.	0.25 to 1.5 In (1)	According to drive rating and [Standard mot. freq] (bFr)
<i>FrS</i>	<input type="checkbox"/> <b>[Rated motor freq.]</b>  Rated motor frequency given on the nameplate. The factory setting is 50 Hz, or preset to 60 Hz if [Standard mot. freq] (bFr) is set to 60 Hz.	10 to 500 or 1600 Hz according to rating	50 Hz
<i>nSP</i>	<input type="checkbox"/> <b>[Rated motor speed]</b>  Rated motor speed given on the nameplate. 0 to 9999 RPM then 10.00 to 96.00 kRPM on the integrated display terminal. If, rather than the rated speed, the nameplate indicates the synchronous speed and the slip in Hz or as a %, calculate the rated speed as follows: <ul style="list-style-type: none"> <li>• Rated speed = Synchronous speed x <math>\frac{100 - \text{slip as a \%}}{100}</math></li> <li>or</li> <li>• Rated speed = Synchronous speed x <math>\frac{50 - \text{slip in Hz}}{50}</math> (50 Hz motors)</li> <li>or</li> <li>• Rated speed = Synchronous speed x <math>\frac{60 - \text{slip in Hz}}{60}</math> (60 Hz motors)</li> </ul>	0 to 96,000 RPM	According to drive rating
<i>tFr</i>	<input type="checkbox"/> <b>[Max frequency]</b>  The factory setting is 60 Hz, or preset to 72 Hz if [Standard mot. freq] (bFr) is set to 60 Hz. The maximum value is limited by the following conditions: <ul style="list-style-type: none"> <li>• It must not exceed 10 times the value of [Rated motor freq.] (FrS).</li> <li>• Values between 500 Hz and 1 Hz are only possible in V/F control and for powers limited to 37 kW (50 HP) for the ATV71W●●●●. In this case configure [Motor control type] (Ctt) before [Max frequency] (tFr).</li> </ul>	10 to 1600 Hz	60 Hz

(1) In corresponds to the rated drive current indicated in the Installation Manual and on the drive nameplate.

# [1.1 SIMPLY START] (SIM-) menu

Code	Name/Description	Factory setting
<p><i>tUn</i></p> <p><i>nO</i> <i>YES</i></p> <p><i>dOnE</i></p>	<p><input type="checkbox"/> <b>[Auto-tuning]</b></p> <div style="border: 1px solid black; padding: 5px; margin: 5px 0;"> <p style="text-align: center;"><b>▲ DANGER</b></p> <p><b>HAZARD OF ELECTRIC SHOCK, EXPLOSION, OR ARC FLASH</b></p> <ul style="list-style-type: none"> <li>• During auto-tuning, the motor operates at rated current.</li> <li>• Do not service the motor during auto-tuning.</li> </ul> <p><b>Failure to follow these instructions will result in death or serious injury.</b></p> </div> <div style="border: 1px solid black; padding: 5px; margin: 5px 0;"> <p style="text-align: center;"><b>▲ DANGER</b></p> <p><b>UNINTENDED EQUIPMENT OPERATION</b></p> <ul style="list-style-type: none"> <li>• The following motor parameters must be correctly configured before starting auto-tuning: [Rated motor volt.] (UnS), [Rated motor freq.] (FrS), [Rated mot. current] (nCr), [Rated motor speed] (nSP), and [Rated motor power] (nPr).</li> <li>• If one or more of these parameters is modified after auto-tuning has been performed, Auto-tuning (tUn) will be set to [No] and the procedure must be repeated.</li> </ul> <p><b>Failure to follow these instructions will result in death or serious injury.</b></p> </div> <p> <input type="checkbox"/> <b>[No]</b> (nO): Auto-tuning not performed.  <input type="checkbox"/> <b>[Yes]</b> (YES): Auto-tuning is performed as soon as possible, then the parameter automatically changes to [Done] (dOnE).  <input type="checkbox"/> <b>[Done]</b> (dOnE): Use of the values given the last time auto-tuning was performed.         </p> <p><b>Important:</b></p> <ul style="list-style-type: none"> <li>• It is essential that the motor parameters ([Rated motor volt.] (UnS), [Rated motor freq.] (FrS), [Rated mot. current.] (nCr), [Rated motor speed] (nSP), [Rated motor power] (nPr)) are configured correctly before starting auto-tuning. If at least one of these parameters is modified after auto-tuning has been performed, [Auto-tuning] (tUn) will return to [No] (nO) and must be repeated.</li> <li>• Auto-tuning is only performed if no stop command has been activated. If a “freewheel stop” or “fast stop” function has been assigned to a logic input, this input must be set to 1 (active at 0).</li> <li>• Auto-tuning takes priority over any run or prefluxing commands, which will be taken into account after the auto-tuning sequence.</li> <li>• If auto-tuning is unsuccessful, the drive displays [No] (nO) and, depending on the configuration of [Autotune fault mgt] (tnL) (consult the CD-ROM supplied with the drive), may switch to [Auto-tuning] (tnF) mode.</li> <li>• Auto-tuning may take 1 to 2 seconds. Do not interrupt; wait for the display to change to “[Done] (dOnE)” or “[No] (nO)”.</li> </ul>	<p>[No] (nO)</p>
<p><i>tUS</i></p> <p><i>tAb</i></p> <p><i>PEnd</i> <i>PrOG</i> <i>FRIL</i> <i>dOnE</i></p>	<p><input type="checkbox"/> <b>[Auto-tuning status]</b></p> <p>(for information only, cannot be modified)</p> <p> <input type="checkbox"/> <b>[Not done]</b> (tAb): The default stator resistance value is used to control the motor.  <input type="checkbox"/> <b>[Pending]</b> (PEnd): Auto-tuning has been requested but not yet performed.  <input type="checkbox"/> <b>[In Progress]</b> (PrOG): Auto-tuning in progress.  <input type="checkbox"/> <b>[Failed]</b> (FAIL): Auto-tuning was unsuccessful.  <input type="checkbox"/> <b>[Done]</b> (dOnE): The stator resistance measured by the auto-tuning function is used to control the motor.         </p>	<p>[Not done] (tAb)</p>

# [1.1 SIMPLY START] (SIM-) menu

Code	Name/Description	Factory setting
<i>PHr</i>	<input type="checkbox"/> [Output Ph rotation]	[ABC] (AbC)
<i>AbC</i> <i>ACb</i>	<input type="checkbox"/> [ABC] (AbC): Forward <input type="checkbox"/> [ACB] (ACb): Reverse This parameter can be used to reverse the direction of rotation of the motor without reversing the wiring.	

## Parameters that can be changed while the drive is running or stopped

Code	Name/Description	Factory setting
<i>I t H</i>	<input type="checkbox"/> [Mot. therm. current]  Motor thermal overload current, to be set to the rated current indicated on the nameplate.	0 to 1.5 In (1) / According to drive rating
<i>Acc</i>	<input type="checkbox"/> [Acceleration]  Time to accelerate from 0 to the [Rated motor freq.] (FrS) (page 33). Make sure that this value is compatible with the inertia being driven.	0.1 to 999.9 s / 3.0 s
<i>Dec</i>	<input type="checkbox"/> [Deceleration]  Time to decelerate from the [Rated motor freq.] (FrS) (page 33) to 0. Make sure that this value is compatible with the inertia being driven.	0.1 to 999.9 s / 3.0 s
<i>LSP</i>	<input type="checkbox"/> [Low speed]  Motor frequency at minimum reference, can be set between 0 and [High speed] (HSP).	0
<i>HSP</i>	<input type="checkbox"/> [High speed]  Motor frequency at maximum reference, can be set between [Low speed] (LSP) and [Max frequency] (tFr). The factory setting changes to 60 Hz if [Standard mot. freq] (bFr) = [60 Hz] (60).	50 Hz

(1) In corresponds to the rated drive current indicated in the Installation Manual and on the drive nameplate.

# Detected faults - causes - remedies

## Drive does not start, no detected fault code displayed

- If the display does not light up, check the power supply to the drive.
- If the drive displays [Freewheel] (nSt) or [Fast stop] (FSt): The Fast Stop and Freewheel functions will keep the drive from starting if the corresponding logic inputs are not powered up. This is normal—these functions are active at zero so that the drive will stop if there is a wire break.
- Make sure that the run command input or inputs are activated in accordance with the selected control mode:
  - [2/3 wire control] (tCC) parameter and [2 wire type] (tCt) parameter (page 32).

### ▲ DANGER

#### LOSS OF PERSONNEL AND EQUIPMENT PROTECTION FEATURES

- Enabling fault inhibition (InH) will disable drive protection features.
- InH should not be enabled for typical applications of this equipment.
- InH should be enabled only in extraordinary situations where a thorough risk analysis demonstrates that the presence of adjustable speed drive protection features poses a greater risk than personnel injury or equipment damage.

**Failure to follow these instructions will result in death or serious injury.**

## Conditions requiring a power reset

The following table lists the conditions where the drive cannot be reset automatically. The drive can be reset by cycling power to the drive after the cause of the condition has been removed. With AI2F, EnF, SOF, SPF and tnF conditions, the drive can also be reset remotely by means of a logic input or control bit (consult the Programming Manual on the CD-ROM supplied with the drive). Detection of EnF, InFA, InFb, SOF, SPF and tnF conditions can be inhibited by the user, and the drive can be reset remotely by means of a logic input or control bit (consult the Programming Manual on the CD-ROM supplied with the drive).

Code	Name	Probable cause	Remedy
A I 2 F	[AI2 input]	• Non-conforming signal on analog input AI2	• Check the wiring of analog input AI2 and the value of the signal.
b D F	[DBR overload]	• The braking resistor is under excessive stress.	• Check the size of the resistor and wait for it to cool down. • Check parameters [DB Resistor Power] (brP) and [DB Resistor value] (brU) (consult the CD-ROM supplied with the drive).
b U F	[DB unit sh.circuit]	• Short-circuit output from braking unit	• Check the wiring of the braking unit and the resistor. • Check the braking resistor.
C r F 1	[Precharge]	• Charging relay control or charging resistor damaged	• Turn the drive off and then back on again • Check the internal connections • Inspect/repair the drive
C r F 2	[Thyr. soft charge]	• DC bus charging (thyristors)	
E E F 1	[Control Eeprom]	• Internal memory, control card	• Check the environment (electromagnetic compatibility) • Turn off, reset, return to factory settings • Inspect/repair the drive
E E F 2	[Power Eeprom]	• Internal memory, power card	
E n F	[Encoder]	• Encoder feedback	• Check [Number of pulses] (PGI) and [Encoder type] (EnS) (consult the CD-ROM supplied with the drive) • Check that the encoder's mechanical and electrical operation, its power supply and connections are correct • Check and, if necessary, reverse the direction of rotation of the motor ([Output Ph rotation] (PHr) parameter on page 35) or the encoder signals
F C F 1	[Out. contact stuck]	• The output contactor remains closed although the conditions for opening have been met	• Check the contactor and its wiring • Check the feedback circuit

# Detected faults - causes - remedies

## Conditions requiring a power reset (cont.)

Code	Name	Probable cause	Remedy
<i>H d F</i>	[IGBT desaturation]	<ul style="list-style-type: none"> <li>Short-circuit or grounding at the drive output</li> </ul>	<ul style="list-style-type: none"> <li>Check the cables connecting the drive to the motor, and the motor's insulation</li> <li>Perform the diagnostic tests via the [1.10 DIAGNOSTICS] menu</li> </ul>
<i>I L F</i>	[internal com. link]	<ul style="list-style-type: none"> <li>Communication between option card and drive</li> </ul>	<ul style="list-style-type: none"> <li>Check the environment (electromagnetic compatibility)</li> <li>Check the connections</li> <li>Check that no more than 2 option cards (max. permitted) have been installed on the drive</li> <li>Replace the option card</li> <li>Inspect/repair the drive</li> </ul>
<i>I n F 1</i>	[Rating error]	<ul style="list-style-type: none"> <li>The power card is different from the card stored</li> </ul>	<ul style="list-style-type: none"> <li>Check the reference of the power card</li> </ul>
<i>I n F 2</i>	[Incompatible PB]	<ul style="list-style-type: none"> <li>The power card is incompatible with the control card</li> </ul>	<ul style="list-style-type: none"> <li>Check the reference of the power card and its compatibility</li> </ul>
<i>I n F 3</i>	[Internal serial link]	<ul style="list-style-type: none"> <li>Communication between the internal cards</li> </ul>	<ul style="list-style-type: none"> <li>Check the internal connections</li> <li>Inspect/repair the drive</li> </ul>
<i>I n F 4</i>	[Internal MFG area]	<ul style="list-style-type: none"> <li>Internal data inconsistent</li> </ul>	<ul style="list-style-type: none"> <li>Recalibrate the drive (performed by Schneider Electric Product Support)</li> </ul>
<i>I n F 5</i>	[Internal-option]	<ul style="list-style-type: none"> <li>The option installed in the drive is not recognized</li> </ul>	<ul style="list-style-type: none"> <li>Check the reference and compatibility of the option</li> </ul>
<i>I n F 7</i>	[Internal-hard init.]	<ul style="list-style-type: none"> <li>Initialization of the drive is incomplete</li> </ul>	<ul style="list-style-type: none"> <li>Turn off and reset</li> </ul>
<i>I n F 8</i>	[Internal-ctrl supply]	<ul style="list-style-type: none"> <li>The control section power supply is incorrect</li> </ul>	<ul style="list-style-type: none"> <li>Check the control section power supply</li> </ul>
<i>I n F 9</i>	[Internal-I measure]	<ul style="list-style-type: none"> <li>The current measurements are incorrect</li> </ul>	<ul style="list-style-type: none"> <li>Replace the current sensors or the power card</li> <li>Inspect/repair the drive</li> </ul>
<i>I n F A</i>	[Internal-mains circuit]	<ul style="list-style-type: none"> <li>The input stage is not operating correctly</li> </ul>	<ul style="list-style-type: none"> <li>Perform the diagnostic tests via the [1.10 DIAGNOSTICS] menu</li> <li>Inspect/repair the drive</li> </ul>
<i>I n F b</i>	[Internal-Th. sensor]	<ul style="list-style-type: none"> <li>The drive temperature sensor is not operating correctly</li> </ul>	<ul style="list-style-type: none"> <li>Replace the temperature sensor</li> <li>Inspect/repair the drive</li> </ul>
<i>I n F c</i>	[Internal-time meas.]	<ul style="list-style-type: none"> <li>Electronic time measurement component</li> </ul>	<ul style="list-style-type: none"> <li>Inspect/repair the drive</li> </ul>
<i>I n F E</i>	[internal- CPU]	<ul style="list-style-type: none"> <li>Internal microprocessor</li> </ul>	<ul style="list-style-type: none"> <li>Turn off and reset Inspect/repair the drive</li> </ul>
<i>O C F</i>	[Overcurrent]	<ul style="list-style-type: none"> <li>Motor parameters not correct</li> <li>Inertia or load too high</li> <li>Mechanical locking</li> </ul>	<ul style="list-style-type: none"> <li>Check the parameters</li> <li>Check the size of the motor/drive/load</li> <li>Check the state of the mechanism</li> </ul>
<i>P r F</i>	[Power removal]	<ul style="list-style-type: none"> <li>The drive's Power Removal function</li> </ul>	<ul style="list-style-type: none"> <li>Inspect/repair the drive</li> </ul>
<i>S C F 1</i>	[Motor short circuit]	<ul style="list-style-type: none"> <li>Short-circuit or grounding at the drive output</li> </ul>	<ul style="list-style-type: none"> <li>Check the cables connecting the drive to the motor, and the motor insulation</li> <li>Perform the diagnostic tests via the [1.10 DIAGNOSTICS] menu</li> </ul>
<i>S C F 2</i>	[Impedant sh. circuit]	<ul style="list-style-type: none"> <li>Significant earth leakage current at the drive output if several motors are connected in parallel</li> </ul>	<ul style="list-style-type: none"> <li>Reduce the switching frequency</li> </ul>
<i>S C F 3</i>	[Ground short circuit]		<ul style="list-style-type: none"> <li>Connect chokes in series with the motor</li> </ul>

# Detected faults - causes - remedies

## Conditions requiring a power reset (cont.)

Code	Name	Probable cause	Remedy
<i>SDF</i>	[Overspeed]	<ul style="list-style-type: none"><li>• Instability or driving load too high</li></ul>	<ul style="list-style-type: none"><li>• Check the motor, gain and stability parameters</li><li>• Add a braking resistor</li><li>• Check the size of the motor/drive/load</li></ul>
<i>SPF</i>	[Speed feedback loss]	<ul style="list-style-type: none"><li>• Encoder feedback signal missing</li></ul>	<ul style="list-style-type: none"><li>• Check the wiring between the encoder and the drive</li><li>• Check the encoder</li></ul>
<i>ENF</i>	[Auto-tuning]	<ul style="list-style-type: none"><li>• Special motor or motor whose power is not suitable for the drive</li><li>• Motor not connected to the drive</li></ul>	<ul style="list-style-type: none"><li>• Check that the motor/drive are compatible</li><li>• Check that the motor is present during auto-tuning</li><li>• If an output contactor is being used, close it during auto-tuning</li></ul>

# Detected faults - causes - remedies

**Auto-reset conditions (customer configured), after the cause has been removed**

## ▲ DANGER

### LOSS OF PERSONNEL AND EQUIPMENT PROTECTION FEATURES

- Enabling fault inhibition (InH) will disable drive protection features.
- InH should not be enabled for typical applications of this equipment.
- InH should be enabled only in extraordinary situations where a thorough risk analysis demonstrates that the presence of adjustable speed drive protection features poses a greater risk than personnel injury or equipment damage.

**Failure to follow these instructions will result in death or serious injury.**

The drive can also be reset by turning the drive off then on again, or by means of a logic input or control bit (consult the Programming Manual on the CD-ROM supplied with the drive).

APF, CnF, COF, EPF1, EPF2, FCF2, LFF2, LFF3, LFF4, nFF, ObF, OHF, OLC, OLF, OPF1, OPF2, OSF, OtF1, OtF2, OtFL, PHF, PtF1, PtF2, PtFL, SLF1, SLF2, SLF3, SPIF, SSF, tJF, and ULF conditions can be inhibited and the drive reset remotely by means of a logic input or control bit (consult the Programming Manual on the CD-ROM supplied with the drive).

Code	Name	Probable cause	Remedy
<i>APF</i>	[Application fault]	<ul style="list-style-type: none"> <li>• Controller Inside card</li> </ul>	<ul style="list-style-type: none"> <li>• Please refer to the card documentation</li> </ul>
CnF	[Com. network]	<ul style="list-style-type: none"> <li>• Interruption in communication</li> </ul>	<ul style="list-style-type: none"> <li>• Check the environment (electromagnetic compatibility)</li> <li>• Check the wiring</li> <li>• Check the time-out</li> <li>• Replace the option card</li> <li>• Inspect/repair the drive</li> </ul>
<i>COF</i>	[CAN com.]	<ul style="list-style-type: none"> <li>• Interruption in communication on the CANopen bus</li> </ul>	<ul style="list-style-type: none"> <li>• Check the communication bus</li> <li>• Check the time-out</li> <li>• Refer to the CANopen User's Manual</li> </ul>
<i>EPF1</i>	[External flt-LI/Bit]	<ul style="list-style-type: none"> <li>• An external device, depending on user</li> </ul>	<ul style="list-style-type: none"> <li>• Correct the external device</li> </ul>
<i>EPF2</i>	[External fault com.]	<ul style="list-style-type: none"> <li>• Communication network</li> </ul>	<ul style="list-style-type: none"> <li>• Correct the communication network and reset</li> </ul>
<i>FCF2</i>	[Out. contact. open.]	<ul style="list-style-type: none"> <li>• The output contactor remains open although the conditions for closing have been met</li> </ul>	<ul style="list-style-type: none"> <li>• Check the contactor and its wiring</li> <li>• Check the feedback circuit</li> </ul>
<i>LCF</i>	[Line contactor]	<ul style="list-style-type: none"> <li>• The drive is not powering up even though [Mains V. time out] (LCt) has elapsed.</li> </ul>	<ul style="list-style-type: none"> <li>• Check the contactor and its wiring</li> <li>• Check the time-out</li> <li>• Check the line/contactor/drive connection</li> </ul>
<i>LFF2</i> <i>LFF3</i> <i>LFF4</i>	[AI2 4-20 mA loss] [AI3 4-20 mA loss] [AI4 4-20 mA loss]	<ul style="list-style-type: none"> <li>• Loss of the 4-20 mA reference on analog input AI2, AI3 or AI4</li> </ul>	<ul style="list-style-type: none"> <li>• Check the connection on the analog inputs</li> </ul>
<i>nFF</i>	[No Flow fault]	<ul style="list-style-type: none"> <li>• Zero fluid</li> </ul>	<ul style="list-style-type: none"> <li>• Check and correct cause of low flow</li> <li>• Check the zero fluid detection parameters (consult the CD-ROM supplied with the drive)</li> </ul>
<i>ObF</i>	[Overbraking]	<ul style="list-style-type: none"> <li>• Braking too sudden or driving load</li> </ul>	<ul style="list-style-type: none"> <li>• Increase the deceleration time</li> <li>• Install a braking resistor if necessary</li> <li>• Activate the [Dec ramp adapt.] (brA) function (consult the CD-ROM supplied with the drive), if it is compatible with the application</li> </ul>
<i>OHF</i>	[Drive overheat]	<ul style="list-style-type: none"> <li>• Drive temperature too high</li> </ul>	<ul style="list-style-type: none"> <li>• Check the motor load, the drive ventilation and the ambient temperature. Wait for the drive to cool down before restarting.</li> </ul>

# Detected faults - causes - remedies

Auto-reset conditions (customer configured), after the cause has been removed (cont.)

Code	Name	Probable cause	Remedy
<i>D L C</i>	[Proc.Overload Flt]	<ul style="list-style-type: none"> <li>Process overload</li> </ul>	<ul style="list-style-type: none"> <li>Check and remove the cause of the overload</li> <li>Check the parameters of the [PROCESS UNDERLOAD] (OLd-) function (consult the CD-ROM supplied with the drive).</li> </ul>
<i>D L F</i>	[Motor overload]	<ul style="list-style-type: none"> <li>Triggered by excessive motor current</li> </ul>	<ul style="list-style-type: none"> <li>Check the setting of the motor thermal current, check the motor load. Wait for the drive to cool down before restarting.</li> </ul>
<i>D P F 1</i>	[1 motor phase loss]	<ul style="list-style-type: none"> <li>Loss of one phase at drive output</li> </ul>	<ul style="list-style-type: none"> <li>Check the connections from the drive to the motor</li> </ul>
<i>D P F 2</i>	[3 output phase loss]	<ul style="list-style-type: none"> <li>Motor not connected or motor power too low</li> <li>Output contactor open</li> <li>Instantaneous instability in the motor current</li> </ul>	<ul style="list-style-type: none"> <li>Check the connections from the drive to the motor</li> <li>If an output contactor is being used, consult the CD-ROM supplied with the drive</li> <li>Test on a low power motor or without a motor: In factory settings mode, output phase loss detection is active [Output Phase Loss] (OPL) = [Yes] (YES). To check the drive in a test or maintenance environment without having to switch to a motor with the same rating as the drive (particularly useful in the case of high-power drives), deactivate output phase loss detection [Output phase loss] (OPL) = [No] (nO).</li> <li>Check and optimize the [Rated motor volt.] (UnS) and [Rated mot. current.] (nCr) parameters and perform an [Auto-tuning] (tUn) operation.</li> </ul>
<i>D S F</i>	[Mains overvoltage]	<ul style="list-style-type: none"> <li>Line voltage too high</li> <li>Disturbed line supply</li> </ul>	<ul style="list-style-type: none"> <li>Check the line voltage</li> </ul>
<i>D t F 1</i>	[PTC1 overheat]	<ul style="list-style-type: none"> <li>Overheating of the PTC1 probes detected</li> </ul>	<ul style="list-style-type: none"> <li>Check the motor load and motor size</li> <li>Check the motor ventilation</li> <li>Wait for the motor to cool before restarting</li> <li>Check the type and state of the PTC probes</li> </ul>
<i>D t F 2</i>	[PTC2 overheat]	<ul style="list-style-type: none"> <li>Overheating of the PTC2 probes detected</li> </ul>	
<i>D t F L</i>	[PTC=LI6 overheat]	<ul style="list-style-type: none"> <li>Overheating of PTC probes detected on input LI6</li> </ul>	
<i>P t F 1</i>	[PTC1 probe]	<ul style="list-style-type: none"> <li>PTC1 probes open or short-circuited</li> </ul>	<ul style="list-style-type: none"> <li>Check the PTC probes and the wiring between them and the motor/drive</li> </ul>
<i>P t F 2</i>	[PTC2 probe]	<ul style="list-style-type: none"> <li>PTC2 probes open or short-circuited</li> </ul>	
<i>P t F L</i>	[LI6=PTC probe]	<ul style="list-style-type: none"> <li>PTC probes on input LI6 open or short-circuited</li> </ul>	
<i>S C F 4</i>	[IGBT short circuit]	<ul style="list-style-type: none"> <li>Power component</li> </ul>	<ul style="list-style-type: none"> <li>Perform a test via the [1.10 DIAGNOSTICS] menu</li> <li>Inspect/repair the drive</li> </ul>
<i>S C F 5</i>	[Motor short circuit]	<ul style="list-style-type: none"> <li>Short-circuit at drive output</li> </ul>	<ul style="list-style-type: none"> <li>Check the cables connecting the drive to the motor, and the motor's insulation</li> <li>Perform a test via the [1.10 DIAGNOSTICS] menu</li> <li>Inspect/repair the drive</li> </ul>
<i>S L F 1</i>	[Modbus com.]	<ul style="list-style-type: none"> <li>Interruption in communication on the Modbus bus</li> </ul>	<ul style="list-style-type: none"> <li>Check the communication bus</li> <li>Check the time-out</li> <li>Refer to the Modbus User's Manual</li> </ul>



# Detected faults - causes - remedies

Auto-reset conditions (customer configured), after the cause has been removed (cont.)

Code	Name	Probable cause	Remedy
<i>S L F 2</i>	[PowerSuite com.]	<ul style="list-style-type: none"> <li>• Communication with PowerSuite</li> </ul>	<ul style="list-style-type: none"> <li>• Check the PowerSuite connecting cable</li> <li>• Check the time-out</li> </ul>
<i>S L F 3</i>	[HMI com.]	<ul style="list-style-type: none"> <li>• Communication with the graphic display terminal</li> </ul>	<ul style="list-style-type: none"> <li>• Check the terminal connection</li> <li>• Check the time-out</li> </ul>
<i>S P I F</i>	[PI Feedback]	<ul style="list-style-type: none"> <li>• PID feedback below lower limit</li> </ul>	<ul style="list-style-type: none"> <li>• Check the PID function feedback</li> <li>• Check the PID feedback supervision threshold and time delay (consult the CD-ROM supplied with the drive)</li> </ul>
<i>S S F</i>	[Torque/current lim]	<ul style="list-style-type: none"> <li>• Switch to torque limitation</li> </ul>	<ul style="list-style-type: none"> <li>• Check if there are any mechanical problems</li> <li>• Consult the CD-ROM supplied with the drive</li> </ul>
<i>E J F</i>	[IGBT overheat]	<ul style="list-style-type: none"> <li>• Drive overheated</li> </ul>	<ul style="list-style-type: none"> <li>• Check the size of the load/motor/drive</li> <li>• Reduce the switching frequency</li> <li>• Wait for the motor to cool before restarting</li> </ul>
<i>U L F</i>	[Proc. Underload Flt]	<ul style="list-style-type: none"> <li>• Process underload</li> </ul>	<ul style="list-style-type: none"> <li>• Check and remove the cause of the underload</li> <li>• Consult the CD-ROM supplied with the drive</li> </ul>

# Detected faults - causes - remedies

## Automatic drive reset after the detected fault or condition is cleared

### ▲ DANGER

#### LOSS OF PERSONNEL AND EQUIPMENT PROTECTION FEATURES

- Enabling fault inhibition (InH) will disable drive protection features.
- InH should not be enabled for typical applications of this equipment.
- InH should be enabled only in extraordinary situations where a thorough risk analysis demonstrates that the presence of adjustable speed drive protection features poses a greater risk than personnel injury or equipment damage.

**Failure to follow these instructions will result in death or serious injury.**

The USF fault can be inhibited and cleared remotely by means of a logic input or control bit ([Fault inhibit assign.] (InH) parameter.

Code	Name	Probable cause	Remedy
<i>CFF</i>	[Incorrect config.]	<ul style="list-style-type: none"> <li>• Changed or removed option card</li> <li>• The current configuration is inconsistent</li> </ul>	<ul style="list-style-type: none"> <li>• Check that there are no card errors.</li> <li>• In the event of the option card being changed/removed deliberately, see the remarks below.</li> <li>• Return to factory settings or retrieve the backup configuration, if it is valid.</li> </ul>
<i>CFI</i>	[Invalid config.]	<ul style="list-style-type: none"> <li>• Invalid configuration The configuration loaded in the drive via the bus or communication network is inconsistent.</li> </ul>	<ul style="list-style-type: none"> <li>• Check the configuration loaded previously</li> <li>• Load a compatible configuration</li> </ul>
<i>HCF</i>	[Cards pairing]	<ul style="list-style-type: none"> <li>• The [CARDS PAIRING] (PPI-) function has been configured and a drive card has been changed</li> </ul>	<ul style="list-style-type: none"> <li>• In the event of a card error, reinsert the original card</li> <li>• Confirm the configuration by entering the [Pairing password] (PPI) if the card was changed deliberately.</li> </ul>
<i>PHF</i>	[Input phase loss]	<ul style="list-style-type: none"> <li>• Drive incorrectly supplied or a fuse blown</li> <li>• Failure of one phase</li> <li>• 3-phase ATV71 drive used on a single-phase line supply</li> <li>• Unbalanced load This protection only operates with the drive on load</li> </ul>	<ul style="list-style-type: none"> <li>• Check the power connection and the fuses</li> <li>• Use a 3-phase line</li> <li>• Disable the fault detection feature [Input phase loss] (IPL) = [No] (nO)</li> </ul>
<i>P r E F</i>	[Power Ident]	<ul style="list-style-type: none"> <li>• The [Power Identification] (Prt) parameter is incorrect</li> <li>• Control card replaced by a control card configured on a drive with a different rating</li> </ul>	<ul style="list-style-type: none"> <li>• Enter the correct parameter (reserved for Schneider Electric product support)</li> <li>• Check that there are no card errors.</li> <li>• In the event of the control card being changed deliberately, see the remarks below</li> </ul>
<i>USF</i>	[Undervoltage]	<ul style="list-style-type: none"> <li>• Line supply too low</li> <li>• Transient voltage dip</li> <li>• Damaged pre-charge resistor</li> </ul>	<ul style="list-style-type: none"> <li>• Check the voltage and the parameters of [UNDERVOLTAGE MGT] (USb-)</li> <li>• Replace the pre-charge resistor</li> <li>• Inspect/repair the drive.</li> </ul>

# Detected faults - causes - remedies

## Option card changed or removed

When an option card is removed or replaced by another, the drive locks in [Incorrect config.] (CFF) mode on power-up. If the card has been deliberately changed or removed, the trip condition can be cleared by pressing the ENT key twice, which **causes the factory settings to be restored** for the parameter groups affected by the card. These are as follows:

### Card replaced by a card of the same type

- I/O cards: [Drive menu] (drM)
- Encoder cards: [Drive menu] (drM)
- Communication cards: Only the parameters that are specific to communication cards
- Controller Inside cards: [Prog. card menu] (PLC)

### Card removed (or replaced by a different type of card)

- I/O card: [Drive menu] (drM)
- Encoder card: [Drive menu] (drM)
- Communication card: [Drive menu] (drM) and parameters that are specific to communication cards
- Controller Inside cards: [Drive menu] (drM) and [Prog. card menu] (PLC)

## Control card changed

When a control card is replaced by a control card configured on a drive with a different rating, the drive locks in [Power Ident] (PrtF) mode on power-up. If the card has been deliberately changed, the trip condition can be cleared by modifying the [Power Identification](Prt) parameter which **causes all the factory settings to be restored**.









**Altivar® 71W Adjustable Speed Drives Simplified Manual  
Instruction Bulletin**

Altivar® is a registered trademark of Schneider Electric. Other trademarks used herein are the property of their respective owners.

Electrical equipment should be installed, operated, serviced, and maintained only by qualified personnel. No responsibility is assumed by Schneider Electric for any consequences arising out of the use of this material.

**Schneider Electric**

8001 Knightdale Blvd.  
Knightdale, NC 27545 USA  
1-888-SquareD (1-888-778-2733)  
[www.schneider-electric.us](http://www.schneider-electric.us)

30072-453-05 08/2009  
© 2009 Schneider Electric All Rights Reserved