

2

1

THIS COPY IS PROVIDED ON A RESTRICTED BASIS AND IS NOT TO BE USED IN ANY WAY DETRIMENTAL TO THE INTERESTS OF PANDUIT CORP.

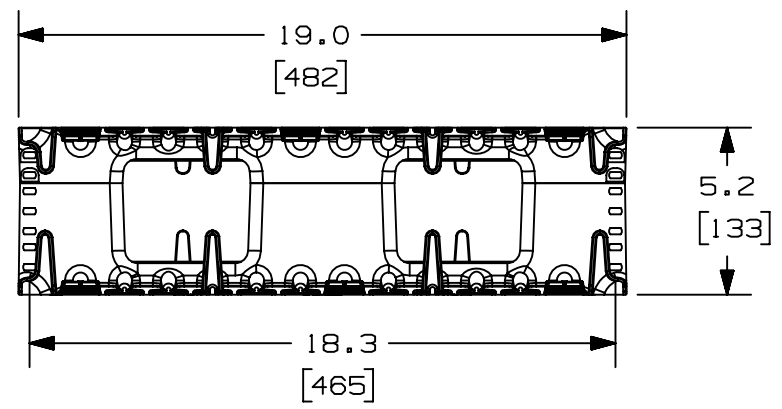

PANDUIT P/N	WEIGHT
NM3	3.3 LBS/EACH 1497 g/EACH
NM3WH	3.3 LBS/EACH 1497 g/EACH

- NOTES:
- VISIT OUR ON-LINE CATALOG AT WWW.PANDUIT.COM FOR A CURRENT LIST OF PRODUCTS APPLICABLE FOR USE WITH THIS PART.
 - COMPONENTS:
1- 3RU MANAGER (FRONT AND REAR)
2- 3RU 19" COVERS
 - DIMENSIONS IN PARENTHESIS ARE METRIC.

MAX STORAGE TEMPERATURE 65° C (149° F)
MAX OPERATING TEMPERATURE 60° C (140° F)

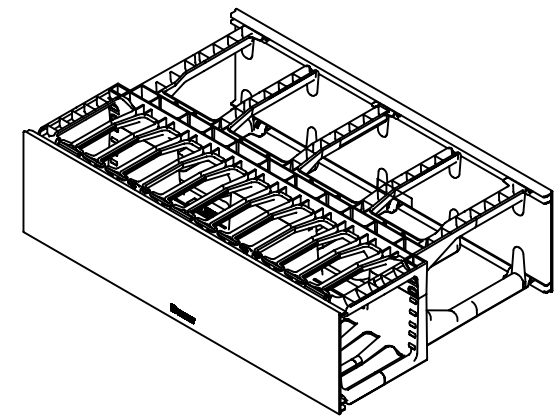
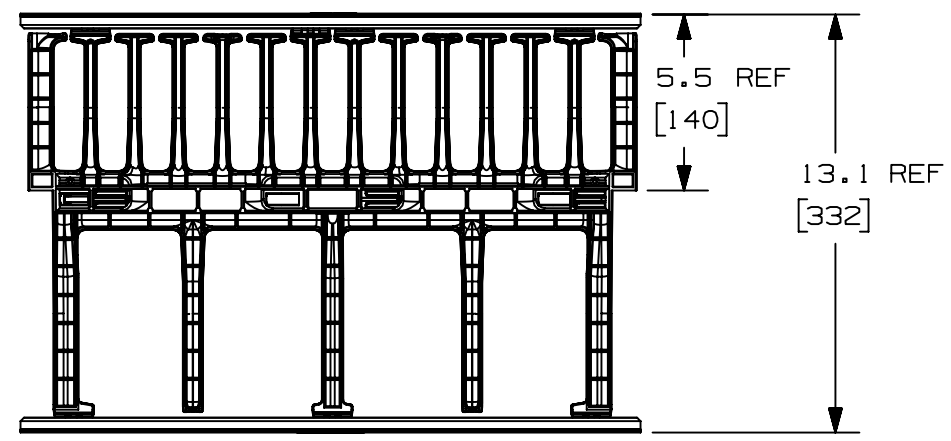

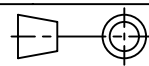
TITLE		NM3 CABLE MANAGER	
		CUSTOMER DRAWING	
ITEM REVISION NAME		V10404AB/03	
DATASET FILE NAME		V10404AB_DC/03B	
		THIRD ANGLE PROJECTION	
MATERIAL		MANAGER: ABS 3 RU COVERS: PVC	
		DRAWING NUMBER 10404-21	
DRAWN BY	DATE	CHK	SCALE
BAME	3/6/07	TCK	N/A
REV		DESCRIPTION	
03B	4/24/20	ADDED TEMPERATURE NOTE	
BY	APR	ECN	
JBO	JCO	M09000LT	
JEFK			

A-SIZE CUSTOMER

2

1